



AALBORG UNIVERSITY
DENMARK

Aalborg Universitet

Macro Protections for Micro Grids

Toward a New Protection Paradigm Subsequent to Distributed Energy Resource Integration

Teimourzadeh, Saeed; Aminifar, Farrokh; Davarpanah, Mahdi; Guerrero, Josep M.

Published in:

I E E E Industrial Electronics Magazine

DOI (link to publication from Publisher):

[10.1109/MIE.2016.2569620](https://doi.org/10.1109/MIE.2016.2569620)

Publication date:

2016

Document Version

Early version, also known as pre-print

[Link to publication from Aalborg University](#)

Citation for published version (APA):

Teimourzadeh, S., Aminifar, F., Davarpanah, M., & Guerrero, J. M. (2016). Macro Protections for Micro Grids: Toward a New Protection Paradigm Subsequent to Distributed Energy Resource Integration. *I E E E Industrial Electronics Magazine*, 10(3), 6-18. <https://doi.org/10.1109/MIE.2016.2569620>

General rights

Copyright and moral rights for the publications made accessible in the public portal are retained by the authors and/or other copyright owners and it is a condition of accessing publications that users recognise and abide by the legal requirements associated with these rights.

- Users may download and print one copy of any publication from the public portal for the purpose of private study or research.
- You may not further distribute the material or use it for any profit-making activity or commercial gain
- You may freely distribute the URL identifying the publication in the public portal -

Take down policy

If you believe that this document breaches copyright please contact us at vbn@aub.aau.dk providing details, and we will remove access to the work immediately and investigate your claim.

Macro Protections for Micro Grids

Toward a New Protection Paradigm Subsequent to DER Integration

Saeed Teimourzadeh, *Student Member, IEEE*, Farrokh Aminifar, *Senior Member, IEEE*, Mahdi Davarpanah, and Josep M. Guerrero, *Fellow, IEEE*,

Introduction

THE need for cleaner and more efficient electrical power generation along with the limited budget for construction of bulky generation and transmission facilities have motivated power system utilities toward deployment of distributed energy resources (DERs). On-site generation by DERs offers various economic and environmental benefits for the end customers, utilities, and society. Among those benefits we can include enhancement of reliability and resilience of power delivery systems as well as deferring new investment for bulky generation, transmission, and distribution expansions. Furthermore, DER integration may lead to lower losses at the transmission system thus reducing emissions of large fossil-fueled power plants [1], [2]. DER integration has modified conventional centralized bulk generation concept and has introduced new notions, such as microgrid (μ G) [3].

A μ G is defined as a low-voltage or medium-voltage system incorporating loads, DERs, and storages with islanded-operation capability, and controlled by an intelligent μ G management system. Although a μ G is seen as an aggregated controllable load/generation from the viewpoint of the upstream network, the main grid is no longer the first and last opportunity for load supply. Through the seamless transfer from grid-connected to islanding operation capability of the μ G, the load may not be interrupted when a blackout occurs in the main grid. This feature mainly results in the enhancement of reliability and resiliency metrics of the power delivery system [4], [5]. In spite of those advantages, large-scale implementation of AC and DC μ Gs present technical challenges and barriers associated with their control, protection, and coordination with the main grid [6]-[12].

In addition to adequate business models, reliable protection systems (PS) are a requisite of long-time, secure, and economic efficient operation of power system. The PS aims to isolate the faulted part of the power system as quickly as possible while preserving the integrity and stability of the remaining system [13]. Accordingly, further damage to the faulted equipment as well as stress on the rest of equipment should be mitigated to a large extent. Reliability is addressed as the main feature of PS, which would be violated when the PS does not operate as is expected. This leads to a two-pronged definition of PS reliability: dependability and security. Dependability is the degree of certainty that the PS would react to a fault for which, is committed; and security is the measure of certainty that the PS would not respond to an irrelevant fault [13]. In addition, the PS should be sensitive, speedy, and selective. The abnormal condition should be detected (sensitivity), at the least time (speedy), and should be cleared by de-energizing the minimum portion of power system (selective) [14].

Conventional distribution systems (DSs), as radial passive networks, were subjected to unidirectional power flows. These systems were mostly protected by current-based protection devices (PDs). Overcurrent, earth fault, and recloser relays with appropriate time-current characteristic have become effective industrial practices in conventional DS for many years. Economic issues are the key reason for the vast deployment of this kind of PDs in conventional DSs. The current magnitude is the individual decision making index for the current-based PDs. Accurate operation of these PDs would be influenced by the factors affecting the fault current magnitude. These factors include the Thevenin equivalent impedance seen from the upstream network, fault type, fault resistance, and grounding strategy. In addition, their coordination is somehow difficult if different time-current characteristics are deployed by PDs [15], [16].

In μ Gs, bidirectional power flows imposed by DERs together with continual fault level variation caused by different operating modes, i.e., grid connected or islanded, would jeopardize current-based protection schemes. In addition, the grounding strategies and interference of μ G control with protection schemes, especially in the case of islanded operation mode, are significant factors in rendering the current-based PDs inadequate to secure a reliable protection scheme for μ Gs. The following issues raise new challenges in the μ G protection [17]-[24]:

- Grounding strategy,

- DER integration,
- Islanded and grid connected operating modes,
- Interference of μ G operation and control with protection.

Designing reliable protection schemes for μ Gs need for elaboration and resolving of new emerging challenges. Although some of the aforementioned challenges could be moderately solved by reprogramming or resetting conventional PDs, their complete solution may require new protection approaches. Protection system must become more “active” and “adaptive” to fulfill the security and dependability requirements of μ G protection. Current-based PDs are not capable of realizing these requirements and new intelligent electronic devices (IEDs)-based PDs with seamless communication capabilities would be essential to accommodate reliable protection schemes in μ Gs. In this sense, those new industrial electronics devices combined with communication-based protection schemes are viable approaches to tackle the aforementioned issues. What is more, synchrophasor measurement technologies (SMT) can provide an effective platform to concentrate the system-wide time-synchronized data in μ G supervision, control, and protection center which can result in issuing more reliable commands [25].

This article explores emerging protection challenges associated with DER-integrated AC μ Gs. The main goal of the article is to highlight the inadequacy of conventional current-based protection schemes subsequent to DER integration. Firstly, the grounding system issues from the protection point of view are discussed. Proper grounding strategies associated with DERs with the aim of meeting the minimum requirements of PDs are also investigated. Afterwards, the impact of DER integration on conventional current-based PDs is addressed including sensitivity matter, sympathetic tripping, and reclosing difficulties. Some initiatives are proposed as well to overcome the aforementioned problems. The interference of control and operation schemes with protection countermeasures is outlined in the subsequent section. Finally, possible solutions based on existing PDs or new advanced technologies, say IEDs and SMT, are discussed for dealing with protection issues following to DER integration.

Grounding System

Power systems are in challenge with numerous types of faults, such as earth faults. Especially phase to ground (P2G) faults are the most common type, for which, the adoption of a proper grounding system from both safety and protection perspectives seems to be the more suitable one. System grounding is the intentional connection to the ground of a neutral conductor for the following purposes [26]:

- Providing a flow path for currents circulating from the ground route and, in consequence, the detection of unwanted connection between system conductors and the ground, i.e. P2G faults;
- Restricting the undesirable voltage with respect to earth, or ground, within tolerable limits.

These targets have led to two sorts of electrical and protective grounding concepts. In the context of the former, the metallic body of electrical equipment should be grounded to alleviate the undesirable voltages, say touch voltage, and consequently avoid electric shock hazards during P2G faults. On the contrary, the protective grounding notion aims at fault current detection in the case of P2G faults.

For current-based PDs, the fault current magnitude is a vital index for the fault diagnosis. In case of earth fault occurrence, the grounding system plays a key role in the ground fault current magnitude by manipulating the fault current contribution of sources.

The fault current contribution of each source is directly affected by the fault current path impedance, including ground impedance in a P2G fault. Adoption of a proper grounding strategy is thus of a crucial prominence for reliable protection of AC μ G. In this section, pros and cons of various protective grounding strategies are discussed and appropriate grounding strategies associated with a variety of DERs are concluded.

Grounding Strategies

The grounding strategies include solidly grounded systems, ungrounded systems (isolated ground), and grounded systems via impedance schemes. In the case of solidly grounded system, the neutral point is connected to the ground through a roughly zero impedance. From the protection perspective, fault diagnosis by current-based PDs and their coordination could be easily accomplished owing to the high short-circuit current magnitude. On the other hand, the overvoltage appeared on the healthy phases during P2G faults is minimum. Accordingly, the resultant voltage stress on the equipment insulation is low and a lower level of insulation may be deployed, and an arrester with lower rated voltage could be also used. However, high P2G fault current may cause thermal and mechanical difficulties. For instance, windings of transformers might be deformed due to the resultant extensive electromechanical forces.

Solid grounding strategies may lead to some protection difficulties subsequent to DER integration. For the sake of illustration, consider Figure 1 as a portion of a μ G. For a P2G fault occurred at point F, the fault would be supplied by both main grid and DER1. Since the main grid is solidly grounded, the major share of fault current would be provided by the main grid. Apart from restrictions imposed by the DER1 generator model, its fault current contribution may be further impacted by the associated grounding strategy. For instance, DER1 would suffer from limited fault current contribution in the case of grounded via impedance. Hence, the sensitivity of PD associated with DER1, PD2, may be at risk. In extreme conditions, with the presence of

a fault resistance, PD2 may even become blind to the fault; while the fault could be easily detected by PD1. In such a case, P2G fault current contribution of DERs should not be restricted as long as the associated PDs miss their sensitivities. To this end, the grounding strategy of DERs should be designed with respect to the grounding approach of the main grid. This matter could be solved using new protection approaches based on communication-enabled IEDs. This issue is discussed in “looking to the future” section.

The counterpart of the solidly grounded system is the ungrounded one which is developed in very special cases such as DSs supplying petrochemical industries. For those rare cases where ungrounded systems are deployed, protection schemes are so different than those of conventional DSs. In the ungrounded system, there is no route for earth fault current except shunt capacitors of the feeders. The shunt capacitor of the distribution feeder is extensively low, which can highly limit the short-circuit current. In this case, the load supplying would not be interrupted due to the low magnitude P2G fault current. In addition, the low magnitude fault current is not capable of raising significant thermal and electromechanical problems. However, such a system endures high level of overvoltage. In addition, ungrounded systems are prone to ferro-resonances. When a P2G fault occurs, the rest of the phases would suffer from overvoltage, which may most likely cause insulation failures. The fault current flows through the shunt capacitor of feeders, and this capacitive fault current may also bring capacitive restriking problems. Due to the low fault current magnitude, isolated systems could not be protected by the means of current-based PDs. The solution is to deploy voltage-based protection schemes. An acute drawback for voltage based protection is the non-selective characteristic of the voltage as a protection index. Voltage-based PDs are usually fed by voltage transformers located at the distribution bus to which numerous feeders may be connected. As a result, the parent bus would be subjected to overvoltage at the event of fault occurrence in each of the feeders. Accordingly, the trip command would be transmitted to all incoming feeders and loads on the sound feeders would be interrupted for an irrelevant fault. This non-selective characteristic of the voltage signal indurates fault locating in DSs.

The compromise between solidly grounded systems and the isolated ones is to accomplish the grounding system by the means of a non-zero impedance. IEEE Std.142-2007 classifies this type of grounding strategy into high-impedance, low-impedance, and effectively grounded notions [26]. As discussed earlier, in solidly grounded system where the grounding impedance is roughly zero, the earth fault current magnitude is high and the overvoltage level is minimum. On the contrary, when the grounding impedance is infinite, i.e. ungrounded systems, the minimum magnitude earth fault current as well as maximum overvoltage would be experienced. Accordingly, the earth fault current and overvoltage factors act conversely while variation of the grounding impedance from zero to infinity. These factors could be adjusted by the strategy of grounding with impedance. There are different policies for sizing the grounding impedance of which the most typical plans are:

- Retaining the P2G fault current and temporary overvoltage indices within satisfactory protection and insulation criteria.
- Restricting the P2G fault current to about nominal current of the associated upstream transformer.

Grounding with impedance approach can be deployed by using both wye and delta winding arrangements. For wye connection, the neutral point could be grounded via inductive, capacitive, or resistive impedance. Due to the overvoltage, resonance, and ferro-resonance issues, grounding by capacitors is not recommended. Neutral grounding resistors (NGRs) can be remarked as the most practical and efficient choice in grounding with impedance strategy.

In the case of delta connection, since no neutral point is accessible, an artificial neutral point should be created. Figure 2 (a) illustrates this approach in which, the artificial neutral point is formed by impedances. The impedances again could be inductive, capacitive, or resistive. In this case, deployment of resistance and inductance are not recommended due to the active and reactive losses. In some special cases, star connected capacitor banks installed for reactive power compensation purposes could be also used for creating the artificial neutral point as a byproduct.

To minimize the leakage shunt current of artificial ground system, the utilized element should offer high impedance during the normal operating mode. However, this element should act as a low impedance during the fault. Three phase transformers with YNd or zigzag winding configuration are appropriate elements to do so. In the case of normal operating mode, only no load current would pass through the grounding transformer. In this occasion, the grounding transformer would operate as a high impedance representing its associated positive sequence impedance. However, P2G fault current would be faced by zero sequence impedance of the grounding transformer which is impressively lower than that of positive one. Figure 2 (b) depicts a sample grounding transformer. Deployment of the zig-zag grounding-transformer is a common practice when the neutral point of the main transformer is not accessible.

DER Grounding Schemes

The typical connections of DERs to μ G include unit-connected and bus-connected configurations. Unit-connected DERs are coupled to μ G using appropriate transformers. However, the bus-connected ones are directly connected to μ G at the low-voltage level. The unbalanced fault current, specifically P2G fault, could vastly jeopardize solidly grounded synchronous machine-based DERs. In case of unbalanced faults, the magnetic flux caused by the negative sequence current may heat up the rotor. Hence, the fault current supplied by the generator should be constrained as much as possible to meet its physical limitations. However, as a cornerstone requirement of current-based PDs, accurate operation of these PDs necessitates fault current provision by resources

for a given period of time. This requirement is called fault-ride-through requirement of PDs. In each network, fulfilling this requirement depends on the model of resources as well as the network structure. Grounding system is one of the momentous factors which can affect the earth fault current and consequently fault-ride-through requirement of PDs. Grounding system should be designed in a way that generators may not be damaged during P2G fault while satisfying PDs requirements. For the interested reader, more about fault-ride-through requirement can be found in [27]-[31].

For the unit-connected DERs, the neutral point of unit transformer (interface transformer) should be grounded using a low-impedance to meet the PDs requirement. Figure 3 depicts a sample unit-connected DER. Since the neutral point of the interface transformer is grounded using a low-impedance NGR, the requirement of PD1 is satisfied for the fault occurring at point B. In addition, due to the delta connection of the transformer winding at generator side, the zero sequence current would not pass through the generator. Since the generator is grounded via a high-impedance NGR, for the P2G fault at point A, low fault current would pass through the generator. The fault current can be restricted to a specific value by proper calculation of the generator grounding NGR, say 10 A.

For the bus-connected generators, to limit the P2G fault current passing through the generator, deployment of a high-impedance NGR is recommended. In this case, the fault would mostly be fed by the main grid in the case of grid connected operating mode. However, fault-ride-through requirement of current-based PDs would not be satisfied in islanded operating mode. In other words, the short-circuit level is considerably low in this condition and, therefore, if the high impedance grounding strategy is adopted for the DERs, the fault current would additionally be attenuated. For this case, the most effective grounding strategy would be grounding with a low-impedance NGR. Accordingly, the grounding strategy of bus-connected DERs should be adaptive with respect to the operating mode. In other words, the grounding system should automatically switch between high-impedance and low-impedance NGRs in the case of grid-connected and islanded operating modes, respectively. Further on DER grounding strategies could be found in [32]-[36].

DER Integration Impact

DER integration in conventional DSs brings about technical challenges associated with its control, protection, and operation viewpoints. From the protection perspective, bidirectional power flows subsequent to DER integration make it neither secure nor dependable to use conventional current-based protection schemes. Designing a reliable protection approach for μ Gs necessitates careful elaboration of DER impact on PDs operation. Fault current routes would be altered subsequent to DER integration; hence, PDs may have not sense when the fault is notably severe. In addition, such a circumstance may result in initiation of irrelevant PDs and consequently the interruption of more loads. Last but not least, multi-path provision of the fault may jeopardize fast load restoration strategies, e.g. reclosing process. Summing up, the most significant impacts of DER connection are outlined as:

- Sensitivity matter,
- Sympathetic tripping issue, and
- Reclosing difficulties.

These issues are thoroughly discussed in the following subsections.

Sensitivity Matter

For conventional DSs, the fault current is fed by a single source. However in μ Gs, DERs also contribute to the fault current, which in turn, might deteriorate the sensitivity of PDs. For the sake of clarity, consider the schematic of a μ G depicted in Figure 4. Before the DER integration, the fault current is only provided by the main grid which is dependent on Thevenin equivalent voltage and impedance of upstream network, feeder impedance, and fault resistance. On the contrary, after DER integration, the main grid contribution to the fault current would be directly affected by the fault current share of DER. As depicted in Fig 4, by a given relatively large Z_{l2} value, PD1 may become blind to the downstream faults for large fault current contribution of DER and high fault resistance value. In other words, as the DER location becomes closer to the PD1, its influence on sensitivity matter of PD1 becomes more severe. Hence, sensitivity of PDs would be jeopardized after DER integration.

This problem is remarkable since PDs approaching to the utility grid are faced with the sensitivity decrement issue which can endanger power system stability and reliability. The story does not end here and sensitivity issue may be intensified in the presence of the fault resistance. Depending on the amount of fault resistance, upstream PDs of DER may also under-reach and remain stable even under fault.

Sympathetic Tripping

As a basic rule of power system protection, the fault should be cleared by de-energizing the minimum part of the system. According to Figure 1, although DER1, main grid, and DER2 contribute to the fault current, PD3 and PDs associated with DER2 should remain stable for the fault occurring at point F. However, when contribution of DER2 to the fault current is high, the sympathetic tripping of PD3 and DER2 protections is inevitable. Therefore, the remained feeder would be interrupted due to sympathetic tripping and may bring about reliability concerns. As a simple idea, although it seems that the problem could be

solved just by using directional overcurrent relays, it is not a complete and comprehensive solution. It is true that by adopting directional over current relays, sympathetic tripping of PD3 could be avoided in some parts. However, this approach would not be effective to mitigate sympathetic tripping for PDs associated with DER2. In addition, when a fault occurs close to PDs, the voltage drop is so severe that may risk the performance of directional PDs. Lastly, equipping all PDs by isolation transformers and implementing directional protections sometimes may not be economically feasible. An alternative solution for this challenge could be developing a logic coordination scheme among PDs. Such a solution may need extra communication infrastructure that would impose associated costs. It is worth noting that some of the protection techniques related to bulky transmission systems can also be efficient in tackling such a matter. For instance in [37], a μ G application of the permissive overreach transfer trip (POTT) notion, as a well-known protection scheme in transmission systems, was investigated. This approach is designed to avoid sympathetic tripping in main loops of μ G. Further, for a particular short-circuit, usually more than 2 PDs are initiated, whereas only the pair which receive permission signal from each other are allowed to issue the trip command. Accordingly, the other PDs remain stable and sympathetic tripping issue is solved.

DERs and Recloser Relays

Power system faults can be classified into temporary and permanent ones, where major part of faults belongs to the temporary category. In the case of temporary faults, the fault factor, say pollution, moisture, and so on, would be subsequently eliminated by the flash-over occurrence. Hence, the equipment can be immediately reenergized. The reclosing idea is based on this philosophy where the tripped circuit breaker would be reclosed after a certain dead time hoping that the fault was temporary. A successful reclose make take place under special conditions. De-energizing the faulted feeder is the basis of a successful reclose. In addition, successful reclose along with minimum blacked-out area can be realized if there exists another PD which can be able to isolate the fault. For conventional DSs, successful reclose command can be fulfilled due to the unidirectional power supply. However, reclosing schemes should be revised after DER integration. For the sake of clarification, consider Figure 5 as a portion of μ G, in which the fault clearance needs tripping both PD1 and PD2. Therefore, in addition to outgoing feeder relay, all DERs on the feeder should also be equipped with recloser units. Moreover, a reliable and successful reclose dictates coordinated operation of PDs; otherwise, it may lead to major problems even in the case of temporary faults. Suppose in Figure 5, the fault location is close to PD1 and hence, PD1 may operate faster than PD2. For a short dead time associated with recloser function of PD1, it is probable that PD2 remains stable. Thus, the fault would be supplied by DER1. By reclosing the PD1, it would switch on to fault which means an unsuccessful reclose. Such a complication could be resolved by deferring the operation of PD1 by means of some intentional delays. This simple example illustrates that the reclosing criterion is not fulfilled even for a temporary fault. Moreover, an additional stress is imposed to both utility grid and DER.

Interference of μ G Operation and Control with Protection

Power system protection, especially current-based schemes, may adversely be influenced by numerous factors. System topology, operating point, and control strategy of resources are the key factors having direct bearing on the power system protection. The aforementioned factors are mostly imposed by system operation and control strategies and power system protection should be capable of making accurate decisions under these conditions. In this section, the impacts of μ G operation and control strategies on its protection and their interference would be discussed.

Consequence of Operation Strategies

Conventional DSs are basically designed in a loop configuration. However, due to safety concerns and technical difficulties, radial configuration is generally deployed in the normal operating mode. Radial configuration in DSs can be accomplished by revising open/close state of switches in the basic loop-designed network. Due to the high number of switches, various configurations could be offered for distribution networks. Expedient reconfiguration is a common measure to realize specific operational destinations such as loss reduction, voltage profile improvement, electrification of interrupted loads, and etc.

System radial operation is the main constraint of the reconfiguration approaches. In the light of various unidirectional power flows provided by radial configuration, the reliable operation of current based protection schemes may rarely be sacrificed. For the sake of illustration, consider Figure 6 (a) as a portion of a conventional DS. Suppose that in the base case, all switches are closed except the tie switch, S9. As obvious from Figure 6 (a), each feeder would be protected by associated PDs, say PD1, PD3, and PD4 for feeder 1 and PD2 for feeder 2. Dependability and security criteria for protection schemes necessitate a coordinated operation of PD1 with PD3 and PD4. Coordination means existence of enough time difference, referred to as coordination time interval (CTI), between operation of the main relay and the backup one. The CTI includes operation time of the main relay and the associated circuit breaker as well as overshoot time of the backup relay plus an appropriate safety margin. Supposing the PDs as the inverse definite minimum time (IDMT) overcurrent relays, the time-current characteristic as well as pickup current and time dial setting (TDS) are the parameters to be tuned. These parameters should be set in order to meet the coordination constraint. For instance, for a fault at point F (see Figure 6 (a)), relay settings associated with PD3 and PD1 should be tuned in a way that the time difference between operation of these PDs becomes equal to or greater than CTI, say 250 ms. Similar

coordination logic should be established between PD4 and PD2.

Assume that an operation strategy offers to reconfigure the network by making S9 and breaking S2. Hence, buses 3, 4 and 5 would be supplied by the other feeder while satisfying radial operation constraint. Referring to Figure 6 (a), again the feeders can be properly protected by the aforementioned PDs; however, in this case, PD2 should be coordinated with PD3 and PD4. The reliable protection of this system can be accomplished by defining proper group settings for both PD1 and PD2. Each group contains PD settings associated with a specific circumstance. For instance, for the aforementioned example, the group settings would be as follows:

- **Group I:** This group should be deployed when S2 is close and S9 is open. In this circumstance, appropriate current settings should be set for all PDs. In addition, the TDSs relevant to PD2, PD3, and PD4 could be adopted independently. However, TDS associated with PD1 should be set with respect to TDSs of PD3 and PD4 to assure proper protection coordination.
- **Group II:** This group should be deployed when S9 is close and S2 is open. Similar to Group I, appropriate current setting should be tuned for all PDs. Also, TDS relevant to PD1, PD3, and PD4 could be adopted independently; while, TDS associated with PD2 should be coordinated with TDSs of PD3 and PD4.

In order to scrutinize the consequence of operation strategy in the presence of DERs, consider Figure 6 (b). After DER integration, the coordinated operation of PD1, PD3, and PD4 would be as the preceding case. PD2 and PD5 can also be set independently. However, the aforementioned reconfiguration plan enforces not only coordinated operation of PD2 with PD3 and PD4, but even PDs associated with DER1, PD5, should be coordinated with downstream ones, PD3 and PD4. Therefore, in addition to PD1 and PD2, group settings would be crucial for PD5 proper operation. The story does not end here. The problem gets more complicated for large scale systems with numerous numbers of DERs and switches offering a vast verity of configurations. Some solutions based on intelligent protection schemes are proposed to deal with those matters [22], [38]. In conclusion, reliable protection of μ Gs obligates careful elaboration of operation maneuver and plans.

Consequence of Control Strategies

Although the philosophy of power system control and protection are based on different aims, consequence of power system control strategies on performance of protection schemes is indisputable. The control approaches try to keep lights on during different operating conditions and under various disturbances. On the contrary, protection system acts in special occasions, say faulty condition, with the aim of removing the abnormality. The PDs are mastermind of the protection system that their accurate operation needs fulfillment of some requirements by control countermeasures. Here is the origin of interference between power system protection and control tasks. As previously mentioned, the fault-ride-through necessity can be stated as one of the vital requirement for the current-based PDs. To satisfy this requirement, the controllers should be able to govern the sources towards providing the required magnitude of fault current within a specific period of time.

For bulk power systems with stabilized bus voltages, PD requirements could be easily fulfilled and the role of the control system is usually overlooked. Likewise, since the conventional DSs are fed only by the main grid, the consequence of control schemes on their protection is negligible. However, protection of μ Gs is directly affected by associated control schemes, particularly in the case of islanded operating mode. For μ Gs incorporating a wide variety of inverter-based DERs (IBDERs), the fault-ride-through requirement is a major concern. During fault, firing pattern of IBDERs would be revisited to restrict the fault current contribution of IBDERs and protect associated power electronic switches. As a result, the contribution of IBDERs to the fault current would be quenched. In addition, swift fault current damping phenomena offered by induction generator-based wind turbines intensify the fault-ride-through issue. The problem, however, could be tackled by developing efficient control plans particularly for doubly fed induction generators (DFIGs).

The fault-ride-through requirement may also be imperiled by control strategies associated with synchronous generator-based DERs (SGBDERs). During faulty conditions, the high magnitude fault current passing through the feeder inductances would result in high reactive losses and inductive current. This inductive current and reactive demand should be supplied by resources to satisfy the fault-ride-through requirement of PDs. For SGBDERs, the excitation system is responsible for voltage control and reactive power provision. Hence, excitation system of SGBDERs and associated controller would play a key role in satisfying fault-ride-through requirement of PDs in μ Gs. Self-excited (shunt) excitation system is broadly deployed in small-scale SGBDERs due to economic reasons. Figure 7 (a) depicts outline of the shunt excitation system. As can be seen from Figure 7 (a), associated terminal voltage of the synchronous machine is utilized to supply the field current.

According to Figure 7 (a), current transformer (CT) and voltage transformer provide feedback signals for automatic control system; however, power potential transformer is responsible for supplying the excitation system. Despite being an inexpensive solution, this system is not suitable for realizing the fault-ride-through constraint of PDs. During faults, voltage drop of the terminal would be transferred to the excitation system. Hence, this system would be lagged in occasions that the system needs urgent backing of the excitation system. Such an incompetency contravenes fault-ride-through requirement of the PDs and consequently imperils their accurate operation. The problem could be mitigated by taking the advantage of a power CT, as depicted in Figure 7 (b). At the event of faults when the current magnitude is high, excitation system would be supplied by the power CT. Once the proper inputs are provided for the excitation system, its controller turns to meet the PDs requirements.

In conclusion, adopting expedient control strategies in μ Gs is of a crucial prominence even from the protection perspective.

μ Gs protection performance should wisely be elaborated along with the design and tuning of μ G control schemes.

Looking to the Future

Reliable protection of future DER-integrated DSs and μ Gs necessitates an advanced protection paradigm. DER integration impacts on DS protection could be resolved using four classes of protection countermeasures. These countermeasures in descending priority order are:

1. **Re-programming of the existing local PDs:** The first and simplest solution is to re-coordinate existing current-based PDs to compensate for the negative influence of DERs on DS protection. This approach seeks to fulfill the protection coordination in presence of DERs by revising PDs settings, i.e. pickup current and TDS. However, not all DER integration issues can be resolved by this approach.

- *Sensitivity:* For this matter, re-coordination scheme could be somehow efficient. PDs should be set more sensitive in the presence of DERs than their absence condition. For instance, the pickup current of PD1 in Figure 4 should be revised in a way that the decreasing impact of DER on the current, sensed by PD1, become compensated for. This approach works when the DER penetration is low. For the cases with proliferated DER penetration, since the reduced level of short-circuit current seen by PD1 would be close to the load current, re-coordination would not alleviate the problem.
- *Sympathetic tripping:* To tackle this difficulty, PDs settings should be set in a way that the trip command by PDs of the sound feeder is not issued for a fault at the other feeder. For instance, PDs associated with DER2 as well as PD3 should not issue trip command when the fault is at point F in Fig. 1. To do so, the time setting of these PDs should be increased. However, this increment would cause additional delay in clearing the faults corresponding to these PDs.
- *Reclosing:* For solving reclosing issue in DER-integrated DSs, the dead time of the recloser should be readjusted. For instance, the dead time associated with PD1 in Fig. 5 should be set in a way that the reclosing command of PD1 is issued after the operation of PD2. In other words, the reclosing dead time should be increased. This increment postpones fast reclosing action which may be harmful for the sensitive loads in μ G.
 - *Consequence of operation strategies:* In DER-integrated DSs, operation strategies alter power flow paths which in turn obligate PD settings revision. Owing to the diversity of operation maneuvers, conventional local PDs cannot tackle this challenge and agent based approaches should be deployed [39].
 - *Consequence of control strategies:* PDs requirement, say fault-ride-through requirement, is the key source of interference between power system protection and control systems which could not be tackled by re-programming of the PDs.

2. **Deploying directional PDs:** In this approach, a new directional PD is deployed to provide appropriate functionality in DER-integrated DSs. Deployment of directional PDs could be efficient in tackling protection issues originated from the bidirectional power flow attribute.

- *Sensitivity:* This matter is not originated from the bidirectional power flow attribute; hence, the directional PDs may not be helpful to solve the problem.
- *Sympathetic tripping:* If the PDs could diagnosis fault current direction, sympathetic tripping issue can be avoided in some parts. For instance, in the case of P2G fault at point F in Fig. 1, sympathetic tripping is alleviated by replacing PD3 with a directional PD. However, this approach would not be effective to resolve sympathetic tripping of PDs associated with DER2.
- *Reclosing:* Directional PDs could not be efficient for solving this problem since this matter is not originated from the bidirectional power flow attribute.
- *Consequence of control and operation strategies:* Likewise the sensitivity and reclosing problems, this matter could not be tackled by deploying the directional PDs; since, it is not emanated from bidirectional power flow attribute.

Briefly, sensitivity, sympathetic tripping, and reclosing issues are partially solved by local countermeasures, i.e., re-programming of the existing PDs and deployment of directional PDs. However, for tackling the remaining protection challenges, these local approaches would not be operative and more advanced schemes such as teleprotection and μ G-wide protection schemes are necessary.

3. **Adopting teleprotection schemes:** This approach enables PDs to be in touch with each other and accordingly steer each other toward the accurate decision. Status indicators of the PDs, such as start and trip indicators as well as fault current direction, are the main signals utilized for this purpose. Trip command of a PD could be accelerated or blocked based on the received indicator from other PDs. Existence of communication infrastructure is the main requirement of this approach. Since the indications are inherently 0 and 1 digits, simple communication links with even very low band-width is sufficient.

- *Sensitivity:* According to Fig. 4, PD1 may become blind to the downstream faults for the high fault current contribution of DER and large fault resistance value. The sensitivity matter of PD1 could be smoothed by accelerating its operation. For instance, assuming PD3 to be directional PD, accelerated group setting should be used if PD2 is started and PD3 is not

started. This logic is depicted in Figure 8. To do so, a communication link should be provided between PD1, PD2 and PD3. Afterwards whenever the mentioned logic is fulfilled, an accelerated group setting would be deployed by PD1. Despite its acceleration, sensitivity matter is not completely resolved since the accurate fault current is not sensed by the PD due to the DER attendance.

- *Sympathetic tripping:* According to Fig. 1, sympathetic tripping of PD3 and PDs associated with DER2 could happen for the fault at point F. As previously discussed, utilization of a directional relay would avoid sympathetic tripping of PD3. On the other, to avoid sympathetic tripping of the PDs associated with DER2, operation of these PDs could be blocked by start indication of PD1.
- *Reclosing:* The reclosing complication imposed by DER integration in Fig. 5 could be resolved if the reclosing action by PD1 is realized after specific delay subsequent to tripping of PD2. To do so, the reclose command of PD1 should be logically ANDed with the trip indication of PD2. Hence, the reclosing would be performed subsequent to de-energizing of the faulty section.
- *Consequence of operation and control strategies:* Teleprotection schemes are not helpful for coping with difficulties originated from μ G operation and control interference with protection system.

4. Devising μ G-wide protection schemes: With the spotlight on industrial electronics solutions, such as automation systems (ASs), availability of new sensors, and emerging IEDs with communication facilities, protection systems could be designed and deployed in the context of these technologies [40, 41]. AS-based protection schemes in μ Gs take advantage of IED two-way communication capabilities enabling more flexible coordination between PDs across the μ G. Deployment of IEDs with both central and distributed intelligence capability would facilitate development of multi-layer protection systems. Moreover, exploiting SMT-based data would escalate observability of μ G which in turn would be helpful in designing efficient control and protection modules for μ G management center. In addition, dynamic phenomena such as islanding and re-synchronizing of μ Gs could be accurately monitored and controlled by the means of SMT-based countermeasures.

- *Sensitivity:* Having applied the AS, IEDs can transfer the appropriate signals, say current and voltage, from all parts of the μ G to the grid information layer. Accordingly, more accurate decisions could be committed using the μ G-wide data.
- *Sympathetic tripping:* To deal with difficulties originated from the miscoordination of PDs, say sympathetic tripping, a μ G-wide logic coordination could be efficient. In this respect, IEDs should submit PDs status, say initiated or not, to the grid information layer. Subsequently, the decision making process would be performed in this layer and the required blocking or tripping commands would be sent to the associated IEDs. Lastly, IED would apply the command to the PD.
- *Reclosing:* Reclosing issue could also be solved in the light of these novel technologies. Precise time stamps provided by SMT could be efficient to avoid switching on to fault while reclosing. In addition, μ G-wide time-synchronized data can be beneficial in defining accurate reclosing time for the μ G stability improvement purpose.
- *Consequence of operation and control strategies:* AS-based approaches could also ease coping with complications imposed by the operation strategies. Subsequent to each maneuver, proper settings would be notified to IEDs; then, associated PDs would be reset by them. To do so, some intelligent approaches are proposed in [24], [38], and [42]. What is more, SMT could be competent in handling interference between μ G control and protection measures. To meet PD requirements, a special μ G-wide control scheme could be devised taking advantage of μ G-wide time-synchronized data.

The summary of the above mentioned discussions are outlined in Table 1. As can be seen, some parts of the challenges could be tackled by re-programming of the existing PDs. However, remaining ones should be attacked by new methods such as, directional PDs and teleprotection schemes. In addition, it is possible to combine these countermeasures and take the advantage of joint approaches. Referring to the fifth column of Table 1, a considerable part of the protection challenges could be resolved by combing teleprotection scheme with existing local countermeasures i.e., re-programming of the existing PDs and deployment of directional PDs. Last but not the least, μ G-wide protection schemes provide comprehensive solution to these challenges. Note that the sophisticated schemes customized for logic programming and remote re-programming of existing PDs, which dictate having a master relay, also belong to the μ G-wide protection schemes category.

Table 1. Summary of four classes of protection countermeasures

Challenges	Solutions				
	Re-programing of existing PDs	Deploying directional PDs	Adopting teleprotection schemes	Joint approaches (1, 2, and 3)	Devising μ G-wide protection schemes
Sensitivity	Partially	No	Almost	Almost	Solved
Sympathetic Tripping	Partially	Partially	Solved	Solved	Solved
Reclosing	Partially	No	Solved	Solved	Solved
Protection and operation interference	Partially	No	No	Partially	Solved
Protection and control interference	No	No	No	No	Solved

Conclusion

In this article, the emerging protection challenges subsequent to the μ G implementation and DER integration have been discussed. These challenges dictate a new line of thinking for designing dependable and secure protection schemes. It was shown that novel protection schemes and technologies might have to be devised to address the new challenges and needs. Having integrated DERs to DSs, some protection difficulties may appear owing to the grounding strategy. Inappropriate adoption of grounding system for DERs may lead to sensitivity deterioration. Accordingly, the grounding strategy of DERs should be determined with respect to the grounding approach deployed in the main grid as well as DERs type of connection, i.e. bus-connected or unit-connected.

In the sequel of DER integration, PDs close to the utility grid would be faced with the loss of sensitivity and sympathetic tripping difficulties. In extreme conditions, with the presence of fault resistance, these PDs may under-reach and remain stable under faulty condition. In addition, the sound feeder would be interrupted owing to the sympathetic tripping problem which would bring about reliability difficulties. Moreover, after DER integration, the reclosing criterion is not fulfilled and PDs may switch-on-to-fault. These issues are to be alleviated in the design of μ G protection systems.

Following to DER integration and μ G implementation, interference of μ G operation and control plans with its protection schemes should be carefully examined. In order to materialize miscellaneous μ G operation maneuvers, adaptive and more complex protection schemes are inevitably being necessitated. Moreover, adopting versatile control strategies in μ Gs is of a crucial prominence from the view point of protection system rigorous performance.

It was discussed that μ G protection challenges can be resolved by the means of industrial electronics solutions, particularly IEDs two-way communication capabilities. The μ G-wide time-synchronized data provided by SMT can also be expedient in solving these challenges. Having realized μ G-wide protection schemes, more precise decisions would be raised under various conditions.

This article focused on the protection challenges originated from inaccurate fault diagnosis due to the exclusive deployment of current-based PDs. However, there are other protection issues which are not scrutinized in this roster. Amongst are islanding detection, transient stability of low-inertia μ Gs, frequency stability of μ Gs in islanded operation mode, and voltage stability of IBDER and SGBDER-integrated μ Gs.

For Further Reading

- [1] J. M. Guerrero, *et al.*, "Distributed generation: toward a new energy paradigm," *IEEE Ind. Electron. Mag.*, vol. 1, no. 4, pp. 52-64, 2010.
- [2] R. H. Lasseter, "Smart distribution: coupled microgrids," *Proc. IEEE*, vol. 99, no. 6, pp. 1074-1082, 2011.
- [3] S. Chowdhury and P. Crossley, *Microgrids and active distribution networks*. The Institution of Engineering and Technology, 2009.
- [4] J. Gurrero, L. G. De Vicuña, and J. Uceda, "Uninterruptible power supply systems provide protection," *IEEE Ind. Electron. Mag.*, vol. 1, no. 1, pp. 28-38, 2007.
- [5] A. Gholami, F. Aminifar, and M. Shahidehpour, "Front lines against the darkness: enhancing the resilience of the electricity grid through microgrid facilities," *IEEE Electrification Magazine*, vol. 4, no. 1, pp. 18-24, 2016.
- [6] T. L. Vandoorn, J. C. Vasquez, J. De Kooning, J. M. Guerrero, and L. Vandeveldel, "Microgrids: hierarchical control and an overview of the control and reserve management strategies," *IEEE Ind. Electron. Mag.*, vol. 7, no.4, pp. 42-55, 2013.
- [7] M. Prodanović and T. C. Green, "High-quality power generation through distributed control of a power park microgrid," *IEEE Trans. Ind. Electron.*, vol. 53, no. 5, pp. 1471-1482, 2006.
- [8] Q. Fu, A. Hamidi, A. Nasiri, V. Bhavaraju, S. B. Krstic, and P. Theisen, "The role of energy storage in a microgrid concept: examining the opportunities and promise of microgrids," *IEEE Electrification Magazine*, vol. 1, no. 2, pp. 21-29, 2013.
- [9] D. Salomonsson, L. Söder, and A. Sannino, "Protection of low-voltage DC microgrids," *IEEE Trans. Power Del.*, vol. 24, no.3, pp. 1045-1053, 2009.
- [10] T. Dragicevic, J. M. Guerrero, and J. C. Vasquez, "A distributed control strategy for coordination of an autonomous LVDC microgrid based on power-line signaling," *IEEE Trans. Ind. Electron.*, vol. 61, no. 7, pp. 3313-3326, 2014.
- [11] C. Jin, P. Wang, J. Xiao, Y. Tang, and F. H. Choo, "Implementation of hierarchical control in DC microgrids," *IEEE Trans. Ind. Electron.*, vol. 61, no.8, pp. 4032-4042, 2014.

- [12] C. Yuan, M. Haj-ahmed, and M. Illindala, "Protection strategies for medium voltage direct current microgrid at a remote area mine site," *IEEE Trans. Ind. Appl.*, vol. 51, no. 4, pp. 1-9, 2015.
- [13] S. H. Horowitz and A. G. Phadke, *Power system relaying*, John Wiley & Sons, 2008.
- [14] A. Oudalov, T. Degner, F. v. Overbeeke, and J. M. Yarza, "Microgrid protection," in *Microgrids*, ed: John Wiley and Sons Ltd, 2013, pp. 117-164.
- [15] J. M. Gers and E. J. Holmes, *Protection of electricity distribution networks*, IET, 2004.
- [16] E. T. Association, *Power System Protection 3: Application*, IET, 1995.
- [17] M. Haj-Ahmed and M. S. Illindala, "Investigation of protection schemes for flexible distribution of energy and storage resources in an industrial microgrid," *IEEE Trans. Ind. Appl.*, vol. 51, no. 3, pp. 1-10, 2014.
- [18] S. Saleh, R. Ahshan, M. Abu-Khaizaran, B. Alsayid, and M. A. Rahman, "Implementing and testing-wpt-based digital protection for microgrid systems," *IEEE Trans. Ind. Appl.*, vol. 50, no. 3, pp. 2173-2185, 2014.
- [19] W. K. Najy, H. H. Zeineldin, and W. L. Woon, "Optimal protection coordination for microgrids with grid-connected and islanded capability," *IEEE Trans. Ind. Electron.*, vol. 60, no. 4, pp. 1668-1677, 2013.
- [20] A. H. Etemadi and R. Iravani, "Overcurrent and overload protection of directly voltage-controlled distributed resources in a microgrid," *IEEE Trans. Ind. Electron.*, vol. 60, no. 12, pp. 5629-5638, 2013.
- [21] D. M. Vilathgamuwa, P. C. Loh, and Y. Li, "Protection of microgrids during utility voltage sags," *IEEE Trans. Ind. Electron.*, vol. 53, no. 5, pp. 1427-1436, 2006.
- [22] S. M. Brahma and A. Girgis, "Development of adaptive protection scheme for distribution systems with high penetration of distributed generation," *IEEE Trans. Power Del.*, vol. 19, no. 1, pp. 56-63, 2004.
- [23] M. Eissa, "Protection technique for complex distribution smart grid using wireless token ring protocol," *IEEE Trans. Smart Grid*, vol. 3, no. 3, pp. 1106-1118, 2012.
- [24] H. Laaksonen, D. Ishchenko, and A. Oudalov, "Adaptive protection and microgrid control design for Hailuoto Island," *IEEE Trans. Smart Grid*, vol. 5, no. 3, pp. 1486-1493, 2014.
- [25] F. Aminifar, M. Fotuhi-Firuzabad, A. Safdarian, A. Davoudi, and M. Shahidehpour, "Synchrophasor measurement technology in power systems: Panorama and state-of-the-art," *IEEE Access*, vol. 2, pp. 1607-1628, 2014.
- [26] "IEEE Recommended Practice for Grounding of Industrial and Commercial Power Systems," ed. IEEE Std.142-2007.
- [27] C. Rahmann, H.-J. Haubrich, A. Moser, R. Palma-Behnke, L. Vargas, and M. B. d. C. Salles, "Justified fault-ride-through requirements for wind turbines in power systems," *IEEE Trans. Power Syst.*, vol. 26, no. 3, pp. 1555-1563, 2011.
- [28] D. Xiang, L. Ran, P. J. Tavner, and S. Yang, "Control of a doubly fed induction generator in a wind turbine during grid fault ride-through," *IEEE Trans. Energy Convers.*, vol. 21, no. 3, pp. 652-662, 2006.
- [29] D. Shin, K.-J. Lee, J.-P. Lee, D.-W. Yoo, and H.-J. Kim, "Implementation of fault ride-through techniques of grid-connected inverter for distributed energy resources with adaptive low-pass notch PLL," *IEEE Trans. Power Electron.*, vol. 30, no. 5, pp. 2859-2871, 2015.
- [30] N. Bottrell and T. C. Green, "Comparison of current-limiting strategies during fault ride-through of inverters to prevent latch-up and wind-up," *IEEE Trans. Power Electron.*, vol. 29, no. 7, pp. 3786-3797, 2014.
- [31] D. Van Tu, S. Chaitusaney, and A. Yokoyama, "Maximum-allowable distributed generation considering fault ride-through requirement and reach reduction of utility relay," *IEEE Trans. Power Del.*, vol. 29, no. 2, pp. 534-541, 2014.
- [32] M. Abedini, M. Davarpanah, and M. Sanaye-Pasand, "Appropriate grounding system for grid-connected small-scale synchronous generators," *IEEE Trans. Ind. Appl.*, vol. 51, no. 6, pp. 5390-5397, 2015.
- [33] P. Pillai, *et al.*, "Grounding and ground fault protection of multiple generator installations on medium-voltage industrial and commercial power systems-part 1: the problem defined working group report" *IEEE Trans. Ind. Appl.*, vol. 40, no. 1, pp. 11-16, 2004.
- [34] P. Pillai, *et al.*, "Grounding and ground fault protection of multiple generator installations on medium-voltage industrial and commercial power systems-part 2: grounding methods," *IEEE Trans. Ind. Appl.*, vol. 40, no. 1, pp. 17-23, 2004.
- [35] P. Pillai, *et al.*, "Grounding and ground fault protection of multiple generator installations on medium-voltage industrial and commercial power systems-part 3: protection methods working group report," *IEEE Trans. Ind. Appl.*, vol. 40, no. 1, pp. 24-28, 2004.
- [36] P. Pillai, *et al.*, "Grounding and ground fault protection of multiple generator installations on medium-voltage industrial and commercial power systems-part 4: conclusion and bibliography working group report," *IEEE Trans. Ind. Appl.*, vol. 40, no. 1, pp. 29-32, 2004.
- [37] L. Che, M. E. Khodayar, and M. Shahidehpour, "Adaptive protection system for microgrids: protection practices of a functional microgrid system," *IEEE Electr. Mag.*, vol. 2, no. 1, pp. 66-80, 2014.
- [38] S. Kar, S. Samantaray, and M. D. Zadeh, "Data-mining model based intelligent differential microgrid protection scheme," *IEEE Syst. J.*, to appear.
- [39] [Online]. Available: <http://www.sandc.com/solutions/self-healing-grids.asp>.
- [40] R. Das, *et al.*, "Distribution automation strategies: evolution of technologies and the business case," *IEEE Trans. Smart Grid*, vol. 6, no. 4, pp. 2166-2175, 2015.
- [41] V. Madani, *et al.*, "Distribution automation strategies challenges and opportunities in a changing landscape," *IEEE Trans. Smart Grid*, vol. 6, no. 4, pp. 2157-2165, 2015.
- [42] D. P. Mishra, S. R. Samantaray, and G. Joos, "A combined wavelet and data-mining based intelligent protection scheme for microgrid," *IEEE Trans. Smart Grid*, to appear.

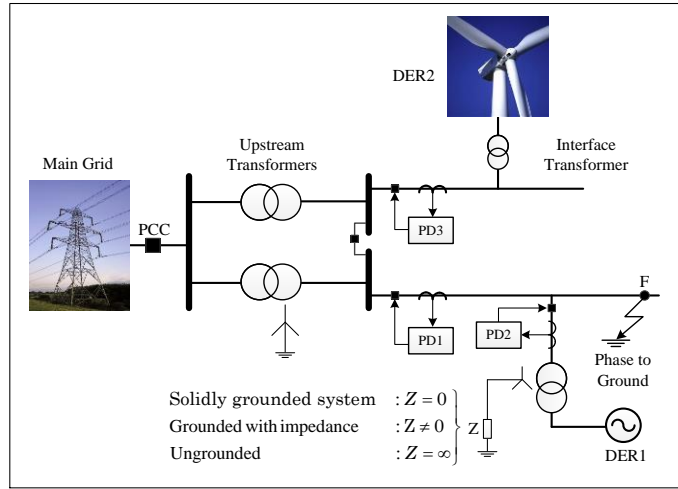

Figure 1. Scheme of a portion of MV μ G.

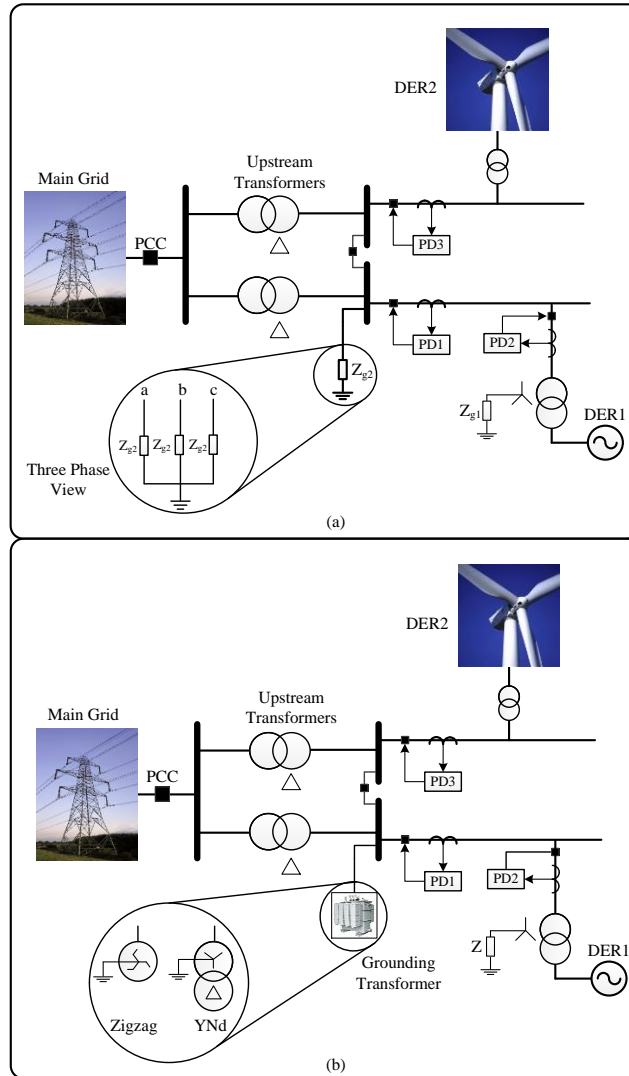

Figure 2. Creating artificial neutral point for MV μ G: (a) via impedance, (b) via grounding transformer.

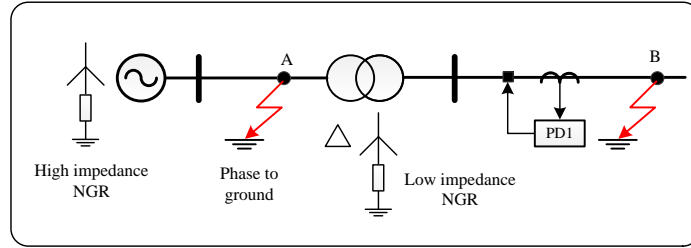

Figure 3. A sample unit-connected DER in MV μ G.

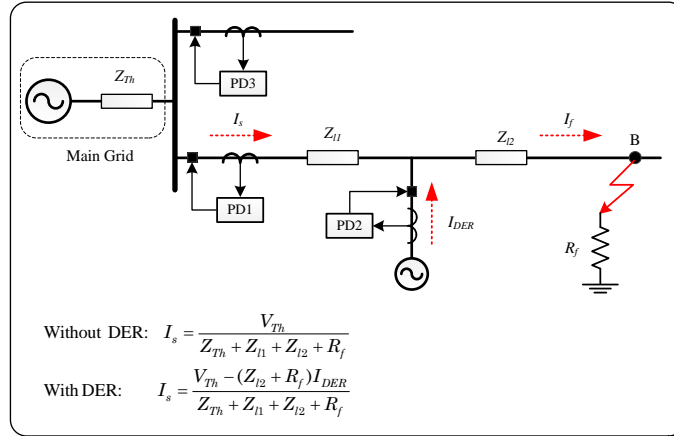

Figure 4. Sensitivity problem subsequent DER integration.

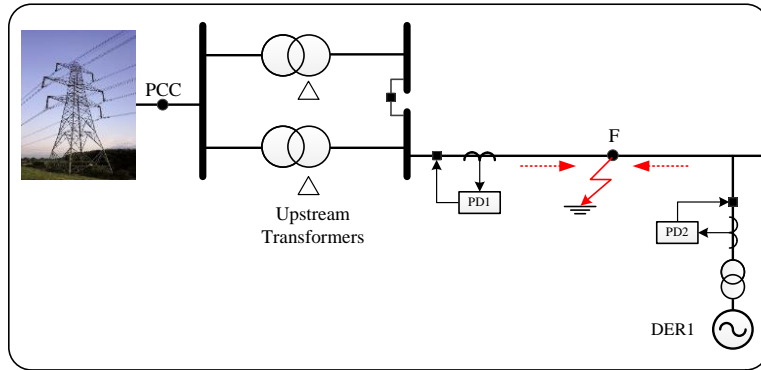

Figure 5. Reclosing problem subsequent to DER integration.

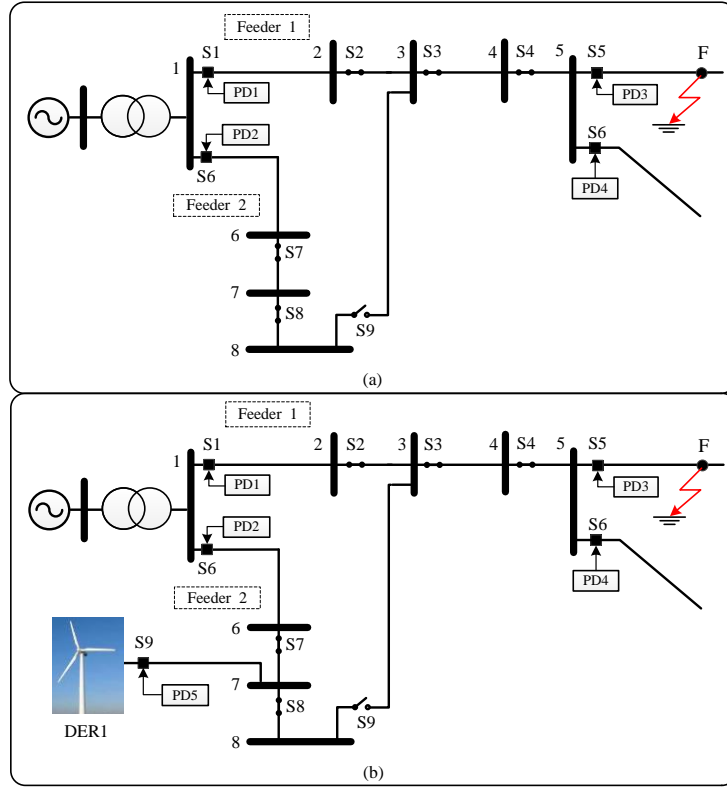

Figure 6. Consequence of operation strategies on protection of DS: (a) Without DER, (b) Subsequent DER integration.

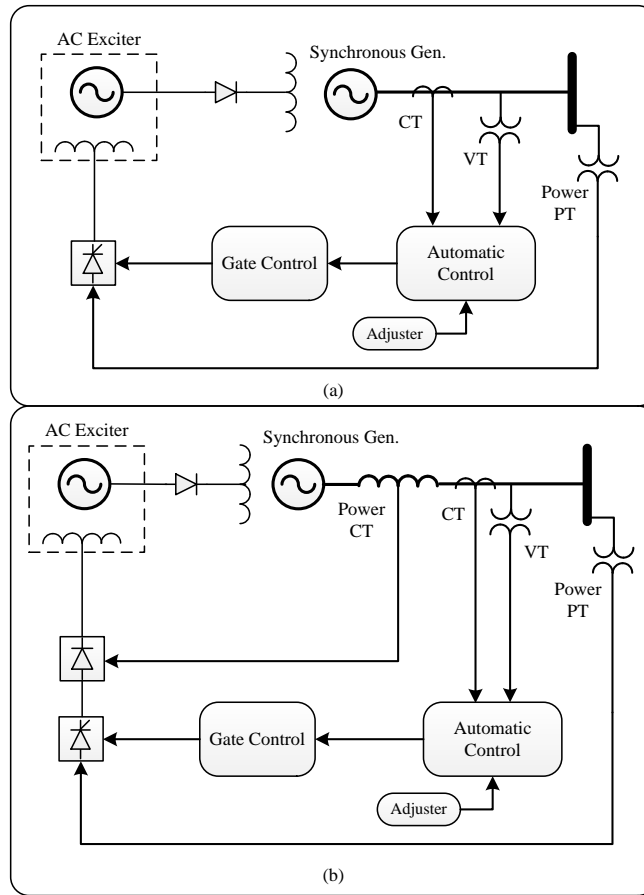

Figure 7. (a) Outline of the shunt excitation system, (b) Outline of the shunt excitation system improved by power CT.

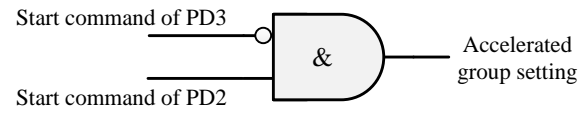

Figure 8. The acceleration logic.