

MAGNETIC BEARING MOMENTUM WHEELS  
 WITH MAGNETIC GIMBALLING CAPABILITY FOR  
 3-AXIS ACTIVE ATTITUDE CONTROL AND ENERGY STORAGE

by

Rainer S. Sindlinger  
 TELDIX GmbH, Heidelberg, Germany

ABSTRACT

Magnetic bearings used for the suspension of momentum wheels provide conclusive advantages: the low friction torques and the absence of abrasion allow the realization of lightweight high-speed wheels with high angular momentum and energy storage capacity and virtually unlimited lifetime. The use of actively controlled bearings provides a magnetic gimballing capability by applying external signals to the two servo loops controlling the rotational degrees of freedom. Thus, an attitude control system can be realized by using only one rotating mass for 3-axis active satellite stabilization. In the future, an integrated energy storage/attitude control system with one pair of counter-rotating rotors could reduce considerably the mechanical complexity and weight of conventional systems.

INTRODUCTION

The stringent attitude performance requirements of future satellites can only be met by 3-axis body stabilization. Hereby, the satellite's orientation is measured by the attitude control system (ACS) with a set of optical, IR or RF sensors, and the deviations from the desired attitude are transformed into appropriate correction signals for the torque actuators. The most common actuators are flywheels, i.e. reaction wheels or momentum wheels.

For 3-axis active control, a set of three REACTION WHEELS with mutually orthogonal axes can be used. Since external disturbance torques are in the order of  $10^{-4}$  to  $10^{-5}$  Nm, an angular momentum storage capacity of 0.2 to 5 Nms is sufficient.

With MOMENTUM WHEELS, active control is only possible in one axis, and the remaining two axes are passively stabilized by gyroscopic effects. The angular momentum  $H$  required to maintain the attitude to an accuracy of  $\Delta\varphi$  at an external torque  $M$  over a time interval  $T$  is

$$H \geq \int_0^T M dt / \Delta\varphi$$

Typical values are in the order of 20 to 100 Nms for an accuracy of  $\Delta\varphi \leq 0.5^\circ$ .

If high angular accuracy is required, this passive stabilization is possible within short time intervals only, and frequent desaturations become necessary. Integration of the wheel into a double gimbal system (DGS) allows to overcome this disadvantage. At the same time, a DGS provides the capability of rotating the satellite, e.g. to correct the north-south error caused by inaccurate positioning or to turn the antenna pointing vector.

Conventional wheels with sliding or ball bearings are restricted to speeds below 5000 rpm due to their friction torque and limited life caused by fatigue effects of the bearings and aging of the lubricants. To prevent the lubricants from outgassing, a housing is needed maintaining an internal pressure of several hundred  $\mu$ bars.

### MAGNETIC BEARING MOMENTUM WHEELS

During the last years, many efforts have been made to avoid the shortcomings of conventional flywheels by use of non-contacting bearings. Due to the absence of abrasion and their very low friction torque, magnetic bearings are prime candidates allowing the design of high-speed wheels with high angular momentum-to-mass and energy-to-mass ratios. Magnetic bearings are insensitive to hard vacuum and therefore need no housing. The lifetime is virtually unlimited and depends only on the reliability of the associated electronics which can be considerably increased by redundancy.

If appropriate materials are used, extreme velocities can be realized, providing an energy storage capability which is competitive to the best available batteries.

For the suspension of a rotating body, 5 degrees of freedom must be stabilized: three translational ones along the X,Y,Z axes, and the rotational ones about the X and Y axes (see Figure 1). Generally, each degree of freedom can either be stabilized passively, i.e. by means of permanent magnets, or actively with magnets controlled by a control loop. A complete passive suspension is not possible and at least one degree of freedom must be actively controlled [1].

PASSIVE SUSPENSION can be realized either with repulsive forces or with secondary forces yielded by attractive magnets. Since only one control loop is required, mainly passive bearings provide high reliability. Using the zero-power method [7] they can operate even in a 1 g environment with low power consumption, because the levitation of the rotor is done by forces generated by permanent magnets.

However, the magnets must be very homogeneous; otherwise considerable friction torque is generated by eddy currents and hysteresis losses. The stiffness is limited yielding a certain softness against external forces and torques. But the most severe disadvantage is the absence of any internal damping, requiring heavy and bulky dampers to prevent nutational and precessional oscillations. In many cases, these dampers are heavier and more voluminous than the bearings themselves. In the 1 g environment these dampers can generate considerable drag torque causing additional power consumption for the drive motor.

For ACTIVE SUSPENSION, two principles of operation can be considered: In an ELECTROMAGNETIC BEARING electromagnets on the stator generate attractive forces on ferromagnetic parts of the rotor. These forces are proportional to the square of the coil current, thus the control loops must include linearizing networks. Two magnets are required for each degree of freedom to yield positive and negative forces.

In the ELECTRODYNAMIC BEARING, the forces are generated by currents through electrical conductors on the stator, arranged perpendicular to the magnetic flux provided by permanent magnets fixed to the rotor. Since the forces are proportional to the current, positive as well as negative forces can be obtained, and the linearity facilitates the layout of the control loops. The forces can be either parallel or orthogonal to the gap between stator and rotor. Of course, the magnitude of the forces is much lower than for the electromagnetic approach.

#### MOMENTUM WHEEL WITH ELECTROMAGNETIC BEARINGS

In the following, a 5-axis active magnetic bearing momentum wheel (MBMW) is described. It was developed and built by Teldix in cooperation with SEP in France under a contract of the COMSAT and the German Space Organization DFVLR.

Two axial bearings AB, having the form of pot magnets, stabilize the rotor in axial direction. They are controlled by the axial sensors AS and a control electronics (see Figure 2).

The two radial bearings RB consist of four pairs of electromagnets each arranged in a plane and equally displaced by 90° as shown in Figure 3. Radial translations are generated by currents at the same side of the upper and lower bearing while torques about the radial axes are provided by activation of opposite sides. The control signals are obtained by addition or subtraction of the outputs of a number of radial sensors RS.

Figure 4 shows a block diagram of the translatory control loops. Since the mass of the rotor provides a double integration, proportional control would yield an oscillating system as it is true for passive bearings. Therefore, a phase-lead network is

necessary to damp oscillations. An integrating control is added to provide high statical stiffness. The frequency response of the control loop is depicted in Figure 5.

At zero speed, the same control loop design could be used for the rotatory degrees of freedom. At higher speeds, however, the two control loops are coupled due to gyroscopic effects. As shown in Figure 6, each variation of the input signal  $\Delta\alpha$  of the X axis causes a disturbing torque  $M_{H\alpha}$  on the Y axis via the differentiating block H.s. It results in a change of the angle  $\beta$  about the Y axis which, in turn, generates the desired angle  $\alpha$  by a disturbing torque  $M_{H\beta}$  about the X axis. Since H is proportional to the rotational speed, the parameters of the control loops vary in a very wide range, and a great bandwidth is required.

### MAGNETIC GIMBALLING CAPABILITY

The use of active magnetic bearings for the rotatory degrees of freedom provides the unique possibility of controlling the attitude of the rotor. If the nominal values  $\alpha_0 = 0$  and  $\beta_0 = 0$  in Figure 5 are replaced by variable command signals  $\alpha_c$  and  $\beta_c$ , the rotor can be tilted by a defined angle about any radial axis. By this tilting, the wheel is provided with a magnetic gimbaling capability.

Such a Magnetically Gimballed Momentum Wheel (MGMW) was developed by Teldix on the basis of the MBMW described above (Figure 7).

A gimbaling angle range of  $\pm 10$  mrad is obtained by increasing the gaps between stator and rotor from 0.3 to about 0.7 mm. At a nominal speed of  $n = 16,000$  rpm, the wheel has an angular momentum of  $H = 100$  Nms, so that the storage capacity about the perpendicular axes is  $\pm 1$  Nms. This is more than sufficient to balance the periodic disturbance torques on the satellite, and the attitude of the satellite can be controlled with an accuracy of better than  $0.01^\circ$ , depending only on the performance of the attitude sensors. Furthermore, the MGMW can be used as an active nutation damper, thus superseding separate nutation dampers for the satellite.

The magnetic gimbaling needs practically no additional hardware. The wider gaps increase the magnetic resistance of the magnetic loops and, therefore, require a higher magnetic potential (i.e. a higher number of ampere-turns). Nevertheless, it was possible to reduce the weight from 14 kg to about 9 kg although effective emergency bearings and a caging mechanism, fixing the rotor during launch, were added.

The electronics package for magnetic suspension and gimbaling and for the motor commutation is integrated in thin film hybrid technology and weighs about 3 kg. Thus, the total system

weight is about 12 kg. The power consumption at nominal operation in orbit is expected to be about 10 to 15 watts. The brushless and ironless d.c. motor/generator is able to provide the power for magnetic suspension in case of primary power failure for up to 20 minutes. Since the electronics is completely redundant, a reliability of about 98 %, based on a 10-year mission, is obtained.

## ROTARY ENERGY STORAGE SYSTEMS

The rotor of the wheel described so far was composed of a momentum ring, a hub, and a disc connecting them. Of course, this is not the optimal shape for a momentum wheel rotor. In order to obtain the highest possible momentum-to-mass ratio  $H/m$ , the total mass should be arranged at the largest possible radius  $r$ , providing a thin-walled ring. The  $H/m$  ratio is then

$$\frac{H}{m} = r \sqrt{\frac{\sigma}{\rho}}$$

with  $\sigma$  being the allowed stresses, and  $\rho$  being the density of the material [4]. If such a ring is rotated at a speed fully utilizing the strength of the material, considerable kinetic energy can be stored providing the opportunity of realizing the dual functions of angular momentum and energy storage.

The energy-to-mass ratio of a thin-walled ring is

$$\frac{E}{m} = \frac{1}{2} \frac{\sigma}{\rho} = \frac{1}{2} v^2$$

with  $v = \omega \cdot r$  being the circumferential velocity. The specific energy is, therefore, fully defined by the properties  $\sigma$  and  $\rho$  of the materials used for the rotor and independent of the ring diameter. High-strength materials of low density are best suited for energy storage systems, and since the stresses are mainly in circumferential direction, fibre reinforced composites are prime candidates for this application. In table 1 the energy density for different materials is listed. The static value is the theoretical limit for the fibres only, while the values given for dynamic loads take into account an energy storage cycling with the associated fatigue problems, and the weight for the matrix, which does not contribute to the strength.

Table 1  
E/m Ratio for Various Ring Materials

Material	Energy-to-Mass Ratio [Ws/g]	
	Static	Dynamic ( $10^5$ cycles)
Steel	250	200
Glass	670	370
Boron	610	425
Carbon	640	500
Kevlar	690	435

As can be seen, carbon fibre composites provide the highest ratio

$$\frac{E}{m} \approx 500 \frac{Ws}{g} \approx 140 \frac{Wh}{kg}$$

#### HIGH-SPEED RING WITH ELECTRODYNAMIC BEARINGS

For such a ring, the dimensions and the mass of an electromagnetic bearing would be prohibitive, and the use of an electrodynamic bearing is to be preferred. The large ring surface allows the use of comparatively large permanent magnets, and the stator coils can be arranged on a ring inside the rotor.

Figure 8 shows a cross section of the bearing: On the rotor, for instance, two permanent magnet rings with homogeneous radial magnetizing in opposite directions are mounted. A soft iron ring increases the flux density effective in the stator coils. The radial and axial coils are arranged in areas where the axial and radial component, respectively, of the magnetic field is predominant. Therefore, the axial coils generate mainly axial forces while radial forces are provided by the radial coils.

To form a complete bearing, the radial coils are divided into four 90° segments providing forces along two perpendicular radial axes. The tilting torques are yielded by segmented axial coils excited in opposite directions. Any deviation from the nominal rotor position is detected by a set of position sensors and - using five control loops - balanced by forces generated in the coils.

This bearing type provides high stiffness and excellent oscillation damping. Due to the absence of any iron on the stator and the uniform magnetizing on the rotor, the drag torque can be kept extremely low even at very high speeds. The only braking torques are caused by eddy currents in the magnets and the soft iron ring, generated by the weak field of the ironless stator coils. If the bearing must be able to support the rotor under 1g, however, about 15 to 25 % of the rotor mass is required for the magnets. Otherwise, the stator coil currents would become intolerably high.

Two counterrotating rings are necessary to realize an energy storage system which is free of distortion torques. A vernier magnetic gimbaling of a few arc minutes is required to exactly align the momentum vectors under all operational conditions. This allows also to generate torques about all three satellite axes. Therefore, the functions of energy storage and attitude control can be combined in one system.

A first experimental model of a high-speed ring was developed by Teldix under a DFVLR contract. Figure 9 shows the complete unit. Although it was mainly designed as a momentum

ring, it is able to store about 45 Wh corresponding to a rotor energy density of 16 Wh/kg.

The total rotor mass is 3.8 kg including 0.6 kg for the magnets. The bearings are able to provide forces of  $F_a > 80$  newtons in axial, and  $F_r > 70$  newtons in radial direction, allowing safe operation in each orientation under 1 g.

The maximum speed up to now was 15,000 rpm, corresponding to an angular momentum of 105 Nms. The total weight is 8.6 kg, and the dimensions are 290 mm diameter  $\times$  110 mm height. The volume is 7.2 l with 4 l available for the electronics in the interior of the stator.

The motor provides a torque of 0.1 Nm corresponding to a power of 150 watts. The angular freedom for magnetic gimbaling is  $\pm 0.1^\circ$ , and the slew torque capacity is more than 2 Nm. The behaviour of the gimbaling loop was tested with a square wave control signal input at a ring speed of 3000 rpm. In Figure 10 the resulting attitude angle of the ring is shown. As can be seen, the commanded angle for the X axis is obtained with a reaction time of less than 20 ms. In the orthogonal Y channel, only short distortions are produced with no steady-state error.

#### CONCLUSION

Magnetic bearing technology allows to realize a 3-axis active attitude control system with only one rotating part. This is possible by using a momentum wheel with magnetic gimbaling capability as a torque actuator for all three body axes. Such a wheel has been developed and will be qualified for space applications within the next two years.

Based on this technology, an integrated energy storage/attitude control system with one pair of counterrotating rings could in the future considerably reduce the complexity and weight of conventional systems.

#### REFERENCES

1. Earnshaw, S.: On the Nature of Molecular Forces. Trans. Cambridge Phil. Soc. 7, 1842.
2. Sindlinger, R.S.: Magnetic Bearing Momentum Wheels with Vernier Gimbaling Capability for 3-axis Active Attitude Control and Energy Storage. IFAC Symposium "Automatic Control in Space", Rottach-Egern/FRG, May 17-21, 1976

---

This paper is based in part on work performed under sponsorship of the International Telecommunications Satellite organization (Intelsat). Any views expressed are not necessarily those of Intelsat.

3. Wehde, H.P. and Sindlinger, R.S.: Rare Earth-Cobalt Magnets, Breakthrough to a new Generation of Drive Motors and Magnetic Bearings for High-Speed Rotors. Second International Workshop on Rare Earth-Cobalt Magnets, Dayton/Ohio, 1976.
4. Stellbrink, K.: Anwendung faserverstärkter Verbundwerkstoffe für magnetisch gelagerte Schwungringe zur Satellitenstabilisierung und als Energiespeicher. DFVLR Report IB 454 75/7, 1975
5. Notti, J.E. et al.: Design and Testing of an Energy Flywheel for an Integrated Power/Attitude Control System. AIAA Paper No. 75 - 1107, 1975.
6. Anderson, W.W. et al.: The Annular Momentum Control Device and potential Applications. NASA TN-D-7866, 1975.
7. Sabnis, A.V. et al.: A Magnetically Suspended Large Momentum Wheel. J. Spacecraft, Vol. 12, No. 7, 1975.

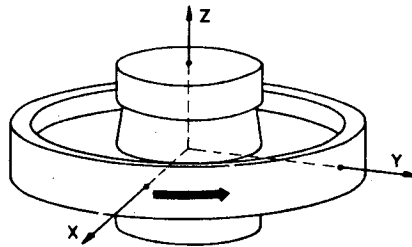

Figure 1: MBMW Coordinate System

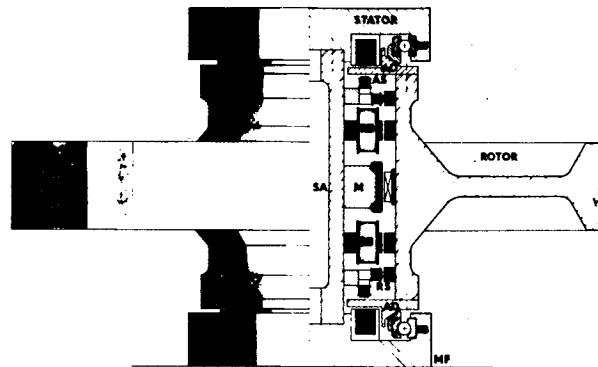

Figure 2: Cross Section of the Magnetic Bearing Momentum Wheel



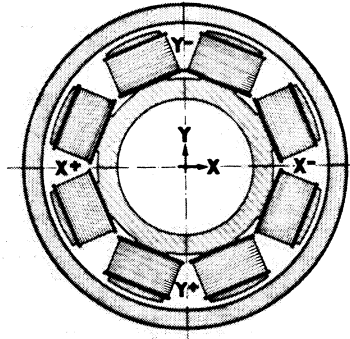

Figure 3: Magnetic Radial Bearing

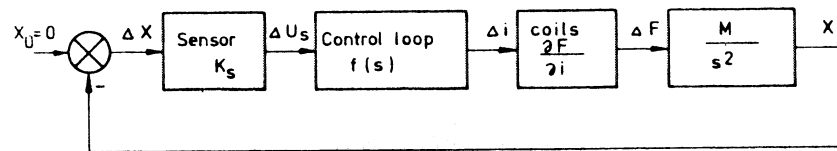

Figure 4: Translational Control Loop

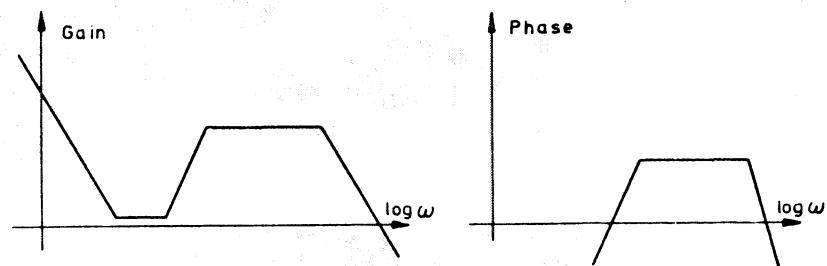

Figure 5: Frequency Response of the Control Loop

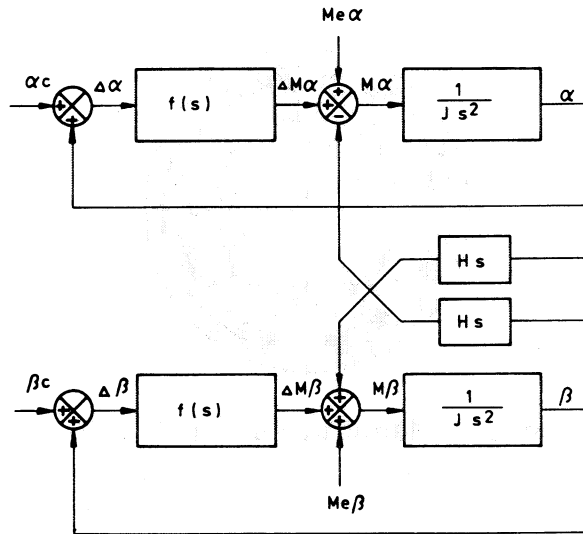

Figure 6: Rotational Control Loops

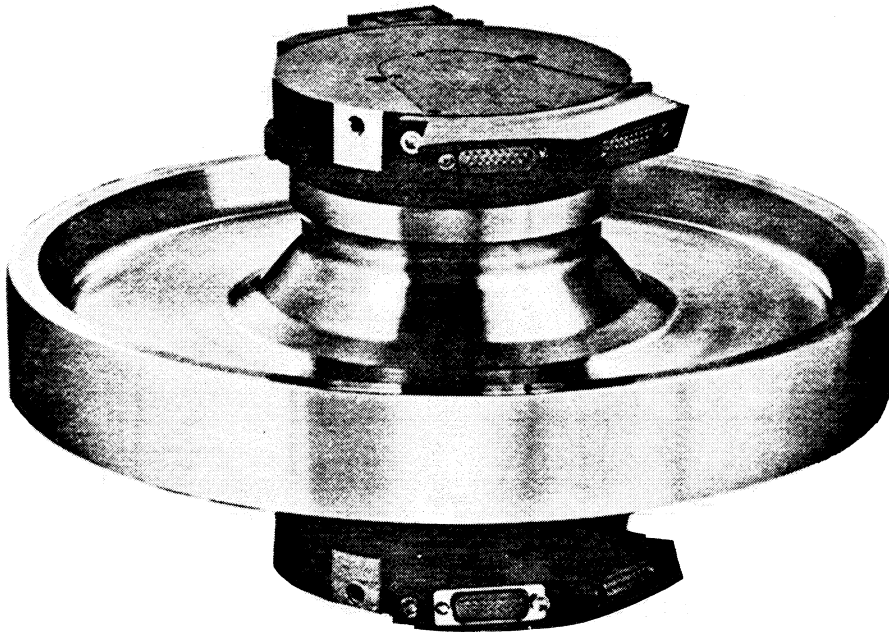

Figure 7: Magnetically Gimbaled Momentum Wheel

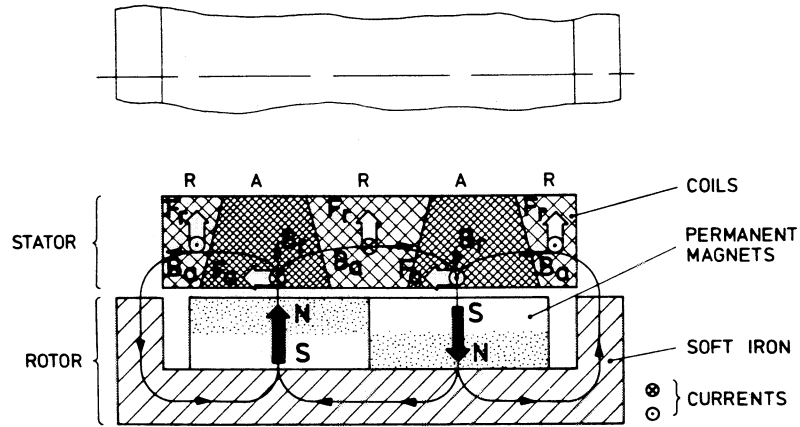

Figure 8: Basic Function of Electrodynamic Bearing

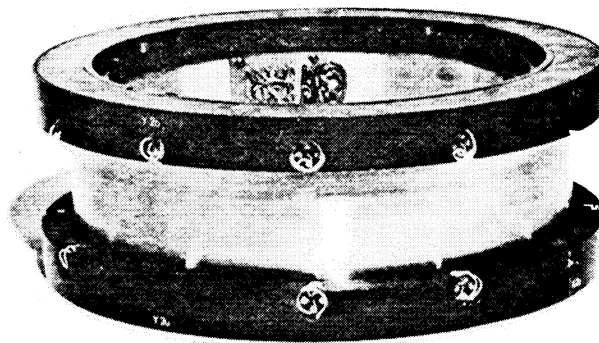

Figure 9: High-Speed Momentum Ring

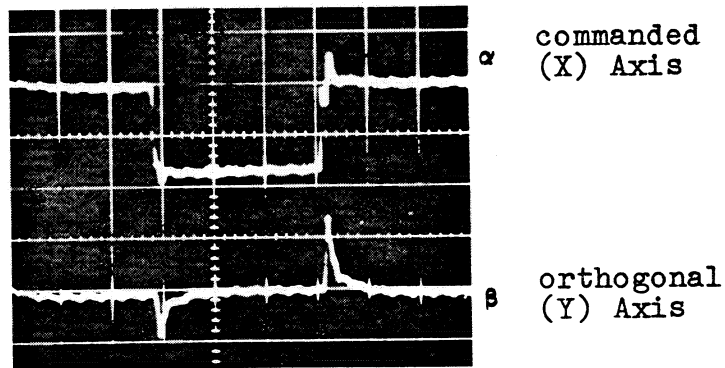

Figure 10: Magnetic Gimballing Angle  
for Square Wave Command Signal  
(vertical 0.4 mrad/Div.; horizontal 50 ms/Div.)

