

Lawrence Berkeley National Laboratory

Recent Work

Title

MAGNETIC FLUX NOISE IN THIN-FILM RINGS OF YBA₃CU₃O₇-DELTA

Permalink

<https://escholarship.org/uc/item/0jf3z4qj>

Authors

Ferrari, M.J.

Johnson, M.

Wellstood, F.C.

Publication Date

1988-05-01

c. 2

Center for Advanced Materials

CAM

TWO-WEEK LOAN COPY

*This is a Library Circulating Copy
which may be borrowed for two weeks.*

Submitted to Applied Physics Letters

Magnetic Flux Noise in Thin-Film Rings of $\text{YBa}_2\text{Cu}_3\text{O}_{7-\delta}$

M.J. Ferrari, M. Johnson, F.C. Wellstood, J. Clarke,
P.A. Rosenthal, R.H. Hammond, and M.R. Beasley

May 1988

RECEIVED
LAWRENCE
BERKELEY LABORATORY

JUL 27 1988

LIBRARY AND
DOCUMENTS SECTION

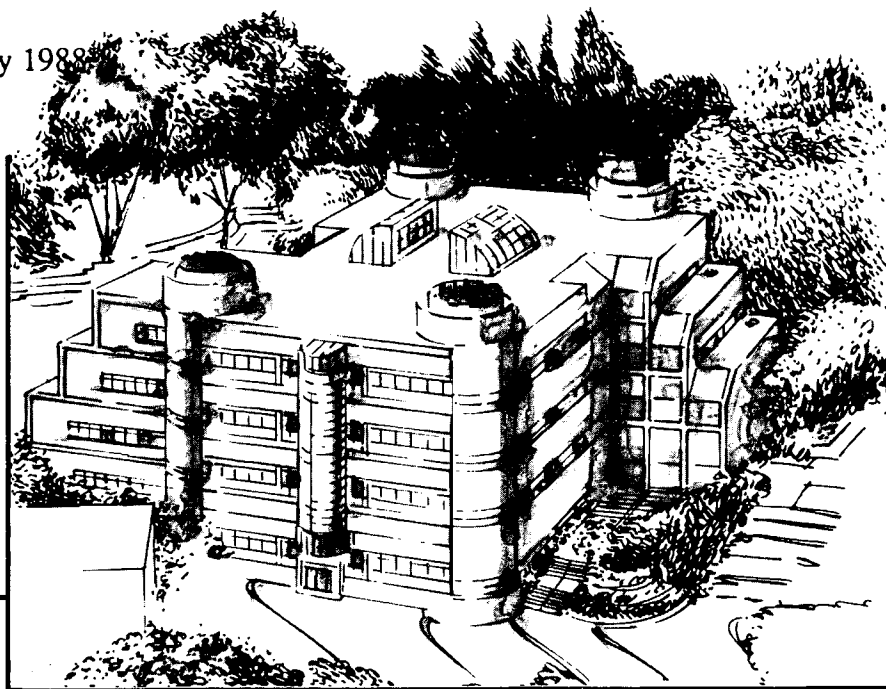

Materials and Chemical Sciences Division
Lawrence Berkeley Laboratory • University of California
ONE CYCLOTRON ROAD, BERKELEY, CA 94720 • (415) 486-4755

LBL-25352
c. 2

DISCLAIMER

This document was prepared as an account of work sponsored by the United States Government. While this document is believed to contain correct information, neither the United States Government nor any agency thereof, nor the Regents of the University of California, nor any of their employees, makes any warranty, express or implied, or assumes any legal responsibility for the accuracy, completeness, or usefulness of any information, apparatus, product, or process disclosed, or represents that its use would not infringe privately owned rights. Reference herein to any specific commercial product, process, or service by its trade name, trademark, manufacturer, or otherwise, does not necessarily constitute or imply its endorsement, recommendation, or favoring by the United States Government or any agency thereof, or the Regents of the University of California. The views and opinions of authors expressed herein do not necessarily state or reflect those of the United States Government or any agency thereof or the Regents of the University of California.

Submitted to Applied Physics Letters
PACS Numbers: 74.40.+k, 74.60.Ge, 74.70.Vy, 74.75.+t

MAGNETIC FLUX NOISE IN THIN-FILM RINGS OF $\text{YBa}_2\text{Cu}_3\text{O}_{7-\delta}$

M. J. Ferrari, Mark Johnson, Frederick C. Wellstood, and John Clarke

Department of Physics, University of California
Center for Advanced Materials, Lawrence Berkeley Laboratory
Berkeley, California 94720

and

P. A. Rosenthal, R. H. Hammond, and M. R. Beasley

Department of Applied Physics
Stanford University
Stanford, California 94305

ABSTRACT

The low-frequency magnetic flux noise in thin-film rings of $\text{YBa}_2\text{Cu}_3\text{O}_{7-\delta}$ (YBCO) is measured over the temperature range 1.3 to 125K by means of a dc Superconducting QUantum Interference Device (SQUID) maintained at liquid helium temperatures. Below the transition temperature T_c of the YBCO, the spectral density of the noise scales as $1/f$, where f is the frequency, and generally increases with increasing temperature. The magnitude of the noise depends strongly on the microstructure of the film, and is lowest for a sample which is predominantly oriented with its c-axis perpendicular to the substrate. These results imply that SQUIDS and flux transformers of YBCO must be fabricated from highly-oriented films to produce good resolution at low frequencies.

Thin-film dc Superconducting QUantum Interference Devices (SQUIDS) fabricated from classic superconductors such as Nb and Pb have been operated routinely as measuring instruments for many years.¹ At 4.2K, the flux noise energy of a typical device with an inductance, L, of the order of 100 pH is $\epsilon(f) = S_{\Phi}(f)/2L = (1-5)10^{-32} \text{ JHz}^{-1}$ at frequencies above the 1/f noise region, where $S_{\Phi}(f)$ is the spectral density of the flux noise at a frequency f. At low frequencies, most of these SQUIDS exhibit 1/f noise¹ with a noise energy $\epsilon(f) \lesssim 10^{-30}/(f/1 \text{ Hz}) \text{ JHz}^{-1}$. This performance is adequate for many practical applications. Over the last year, a number of authors²⁻⁵ have fabricated dc SQUIDS from films of $\text{YBa}_2\text{Cu}_3\text{O}_{7-\delta}$ (YBCO), and operated them at temperatures up to 77K. However, relatively few noise measurements have been reported, and only over a limited temperature range. Koch et al.² reported $S_{\Phi}(100\text{Hz}) = 10^{-6}\Phi_0^2 \text{ Hz}^{-1}$ at 40K, a value limited by voltage noise in the preamplifier; with the quoted loop inductance of 80 pH, this flux noise corresponds to $\epsilon \approx 3 \times 10^{-26} \text{ JHz}^{-1}$. Subsequently, devices of this kind have shown a noise energy at 40K of about $3 \times 10^{-30} \text{ JHz}^{-1}$ at 1 kHz, increasing as 1/f at lower frequencies.⁶ At 77K, the noise energy again varied as 1/f at low frequencies, with a value of about $2 \times 10^{-25} \text{ JHz}^{-1}$ at 1 Hz. Thus, although the resolution of these devices is good at frequencies above the 1/f region, the 1/f noise is much larger than in classic SQUIDS at 4.2K, and is potentially a limitation on the usefulness of high- T_c SQUIDS for low-frequency applications in, for example, geophysics and biomagnetism.

In this Letter we report a systematic study of the magnetic flux noise in thin-film loops of YBCO with various microstructures over the temperature range from 1.3K to 125K. The measured noise sets a lower

bound on the flux noise to be expected from SQUIDs of comparable geometries fabricated from similar materials. It is also hoped that these measurements will shed light on the physical origin of the noise, and enable one to reduce its magnitude.

The experimental configuration is sketched in Fig. 1. A Nb-PbIn SQUID in a square washer configuration on a sapphire substrate is attached to a sapphire plate. This plate is clamped to the flange of a vacuum can immersed in liquid ^4He , so that the temperature of the SQUID is close to that of the bath. A film of YBCO approximately 200 nm thick with the same dimensions as the SQUID loop is fabricated on a SrTiO_3 chip that is then mounted on a larger Si plate. The Si plate is attached to a fiberglass mount that has weak thermal coupling to the sapphire plate. We use a heater on the reverse side of the Si plate to raise the temperature of the sample as high as 125K without disturbing the operation of the SQUID. A platinum resistance thermometer measures the temperature of the plate. A small modulation and feedback coil enables one to operate the SQUID in a flux-locked loop, with a typical bandwidth of a few kHz. The SQUID and YBCO loop are magnetically shielded by a Pb can, and the cryostat is surrounded by a mu-metal cylinder to minimize the magnetic field in which the sample is cooled.

We have studied three films of YBCO, the properties of which are summarized in Table I. Samples 1 and 2 were coevaporated onto SrTiO_3 substrates at ambient temperature in flowing O_2 , and subsequently annealed as described in detail previously.⁷ Sample 3 was cosputtered in 0.7 m torr of Ar and 0.1 m torr of O_2 at ambient temperature, and annealed similarly. The films were patterned photolithographically and

etched in dilute nitric acid. X-ray studies showed that sample 1 was mostly polycrystalline with some a- and c-axis oriented grains; its low transition temperature of about 47K was probably due to underannealing. Sample 2 had mixed a- and c-axis orientation, while sample 3 was predominantly c-axis oriented. These latter two films should be typical of the current state-of-the-art in postannealed YBCO films.

We determined the mutual inductance $M = \alpha(LL_{\phi})^{1/2}$ between the SQUID and the loop of inductance L_{ϕ} from the modulation depth ΔI_C of the critical current of the SQUID. Here, α is the coupling coefficient and ΔI_C is the difference between the maximum and minimum critical currents observed when one varies the flux applied to the SQUID. The dependence of ΔI_C on temperature for sample 3 is shown in Fig. 2. Above the transition temperature, T_C , the SQUID is unshielded by the YBCO loop, and we estimate $\beta = 2LI_0/\phi_0 = 2$, where $L \approx 400$ pH, $I_0 = 5$ μ A is the critical current per junction, and $\phi_0 \equiv h/2e$ is the flux quantum. Below T_C , the SQUID inductance is reduced to $L' = L(1 - \alpha^2)$ by the screening action of the YBCO loop, and ΔI_C is correspondingly increased. We estimate L' from Fig. 4 of ref. 8, and hence deduce the value of α , which ranged from 0.6 to 0.7. The spectral density of the flux noise in the loop is given by $S_{\phi}(f) = S_{\phi}^S(f)/\alpha^2$, where $S_{\phi}^S(f)$ is the noise observed in the SQUID.

Figure 3 shows $S_{\phi}(f)$ for sample 1 at three temperatures. At 4.2K $S_{\phi}(f)$ varies approximately as $1/f$ over the measured frequency range, with a value of $9 \times 10^{-7} \phi_0^2 \text{ Hz}^{-1}$ at 1 Hz. The excess noise of the loop becomes comparable with the white noise of the SQUID at about 1 kHz. When the temperature was increased to 44K, the noise power increased by a factor of about 600. At 80K (well above the transition temperature

of this sample) the measured noise corresponded to the intrinsic noise of the SQUID, with no discernible contribution from the YBCO loop.

In Figure 4 we plot the spectral density of the noise at 1 Hz vs. temperature for the three samples of Table I. The spectral density of the noise in the SQUID has been subtracted. At low temperatures, the noise power scales as $1/f$ and increases with increasing temperature. Just below T_c (which we define as the temperature at which the inductive screening of the SQUID by the YBCO film vanishes), the noise increases steeply with temperature. Just above T_c , the noise drops very rapidly with increasing temperature, and its spectral density is no longer $1/f$; the detailed behavior of each sample is different. For example, for sample 1 above T_c we observed a knee frequency in some spectra, below which the noise was white and above which it was approximately $1/f$. At point A this knee frequency was near 10 Hz, at point B it was near 100 Hz, and at point C the noise was white over the bandwidth of the measurement. The white noise observed in samples 1 and 3 over a range of temperature indicated by dashed lines was so large that we could not maintain the SQUID in flux-locked operation. At sufficiently high temperatures, the noise from the YBCO is below the noise of the SQUID. We note that although the peak noise magnitudes are not very different for all three films, the magnitudes at temperatures well below the peaks decrease substantially as the film quality improves progressively from sample 1 to sample 3. Furthermore, the data indicate a weaker temperature dependence for sample 3 in this temperature range.

We tentatively ascribe the noise to the motion of flux quanta or possibly bundles of flux quanta in the film. Similar sources of flux

noise (of much lower magnitude) have been suggested⁹ for Nb-based dc SQUIDS, and it is possible but not a foregone conclusion that the underlying mechanism is the same for YBCO and Nb. If one assumes a distribution of times τ_i for the flux hopping process, one expects to find a $1/f$ power spectrum from the superposition of Lorentzian spectra in the usual way.¹⁰ As the temperature is increased, one expects the hopping frequency to increase, as more processes with higher activation energies move into the range of measured frequencies. Indeed, for sample 1 we see knee frequencies at points A and B, while at C the characteristic frequencies ($\sim 1/\tau_i$) have presumably shifted to values greater than 1kHz, producing a white power spectrum in the measured frequency range. From the temperature dependence of the noise at low temperatures, we estimate the activation temperatures to be no greater than 2K for samples 1 and 2 and of the order of 10K for sample 3.

We estimate the flux noise energy for our best film, sample 3, assuming an inductance of 400 pH. We find $\epsilon(1 \text{ Hz}) \approx 1 \times 10^{-27} \text{ JHz}^{-1}$ in the vicinity of 77K, the boiling point of liquid N_2 , and $\epsilon(1 \text{ Hz}) \approx 7 \times 10^{-29} \text{ JHz}^{-1}$ at 28K, the boiling point of liquid Ne. Although these $1/f$ noise values are substantially higher than those obtained in Nb-based devices at 4.2K, nonetheless the value at 28K would be adequate for many applications of SQUIDS.

In summary, we have shown that the low-frequency flux noise in YBCO loops has a $1/f$ spectral density and increases rapidly with temperature. The noise decreases markedly as the degree of crystallographic orientation of the films is improved, and is lowest for a highly oriented c-axis film. There is, of course, no reason to believe that the lowest noise reported here cannot be improved upon: We

expect further reductions in noise as the film quality is improved. These measurements imply that very high quality films of YBCO are required to yield reasonably low levels of $1/f$ noise in dc or rf SQUIDs; furthermore, coils and flux transformers coupled to the SQUIDs should also have the best possible microstructural properties.

We are grateful to K. Char and T. Hylton for providing the sputtered films and to R. H. Koch for helpful discussions. This work was supported by the Office of Naval Research under Contract No. ONR N00014-83-K-0391, and by the Director, Office of Energy Research, Office of Basic Energy Sciences, Materials Sciences Division of the U.S. Department of Energy under Contract No. DE-AC03-76SF00098.

Table I. Properties of three YBCO samples.

| Sample # | SrTiO ₃ orientation | YBCO orientation | T _c K | J _c (4.2K) ^a A/cm ² |
|----------|-----------------------------------|---------------------|---------------------|---|
| 1 | 18° from <100> | polycrystalline | 47 | — |
| 2 | <100> | mixed a- and c-axis | 85 | 2 × 10 ⁴ |
| 3 | <100> | > 90% c-axis | 85 | 5 × 10 ⁶ |

^a From magnetization measurements prior to patterning.

REFERENCES

1. For example, see J. Clarke, *Physics Today* 39, 36 (1986).
2. R. H. Koch, C. P. Umbach, G. J. Clark, P. Chaudhari, and R. B. Laibowitz, *Appl. Phys. Lett.* 51, 200 (1987).
3. H. Nakane, Y. Tarutani, T. Nishino, H. Yamada, and U. Kawabe, *Jap. J. Appl. Phys.* 26, L1925 (1987).
4. B. Häuser, M. Diegel, and H. Rogalla, *Appl. Phys. Lett.* 52, 844 (1988).
5. P. Chaudhari, J. Mannhart, D. Dimos, C. C. Tsuei, J. Chi, M. M. Oprysko, and M. Scheuermann, *Phys. Rev. Lett.* 60, 1653 (1988).
6. R. H. Koch, private communication.
7. M. Naito, R. H. Hammond, B. Oh, M. R. Hahn, J. W. P. Hsu, P. Rosenthal, A. F. Marshall, M. R. Beasley, T. H. Geballe, and A. Kapatulnik, *J. Mat. Res.* 2, 713 (1987).
8. C. D. Tesche and J. Clarke, *J. Low Temp. Phys.* 29, 301 (1977).
9. R. H. Koch, J. Clarke, W. M. Goubau, J. M. Martinis, C.M. Pegrum and D. J. Van Harlingen, *J. Low Temp. Phys.* 51, 207 (1983).
10. A. Van der Ziel, *Physica* 16, 359 (1950).

FIGURE CAPTIONS

- Fig. 1 Experimental configuration: (a) perspective view of YBCO film, SQUID and coil, and (b) side view showing mounting arrangement. A is the SQUID substrate, B is the sapphire plate, C is the modulation and feedback coil, D is the SrTiO_3 substrate, E is the silicon plate, F is the heater, and G is the thermometer.
- Fig. 2 Normalized modulation depth of the critical current of the SQUID, $\Delta I_c(T)/\Delta I_c(4.2\text{K})$, vs. temperature for sample 3.
- Fig. 3 Power spectra of observed flux noise for sample 1 at 3 different temperatures. At 80K, the spectrum is that of the SQUID, divided by α^2 .
- Fig. 4 Spectral density of flux noise at 1 Hz vs. temperature for 3 samples: squares, sample 1; triangles, sample 2; circles, sample 3. The spectral density of the SQUID noise has been subtracted. Solid symbols imply that the spectral density is $1/f$ at 1Hz, open symbols that it is white or nearly white. Downward arrows above T_c indicate upper limits on the noise from the sample loops.

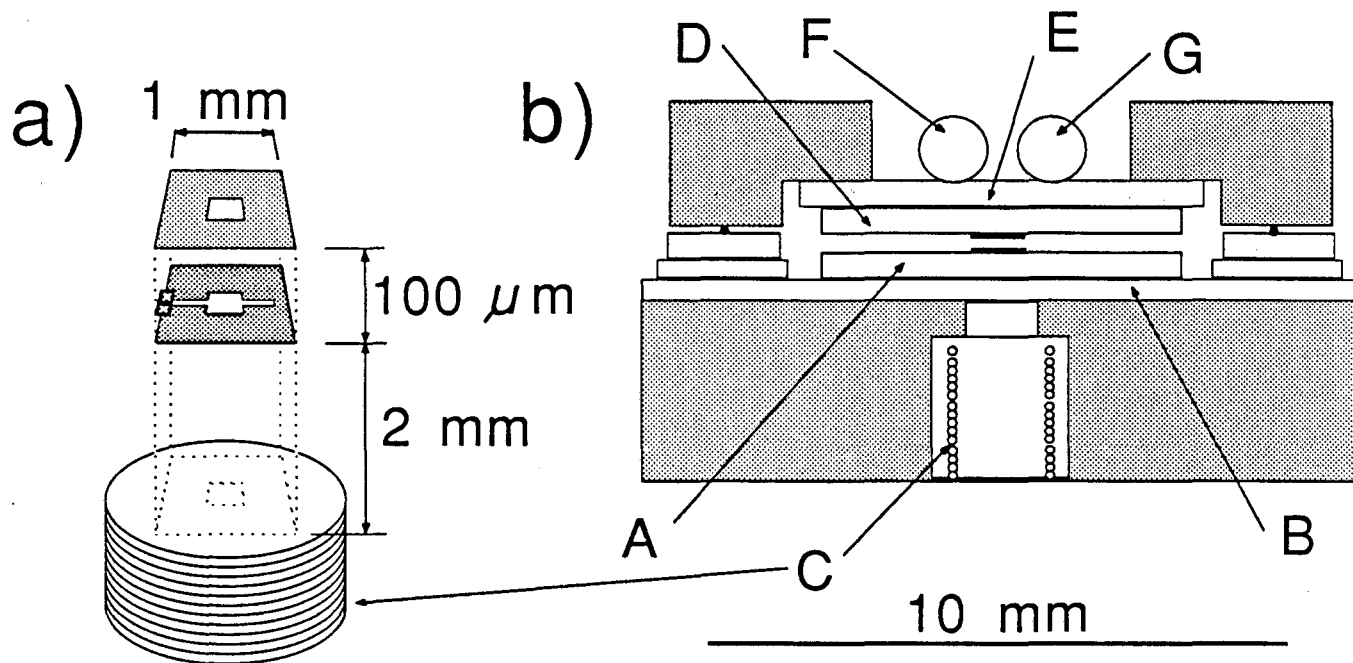

Figure 1

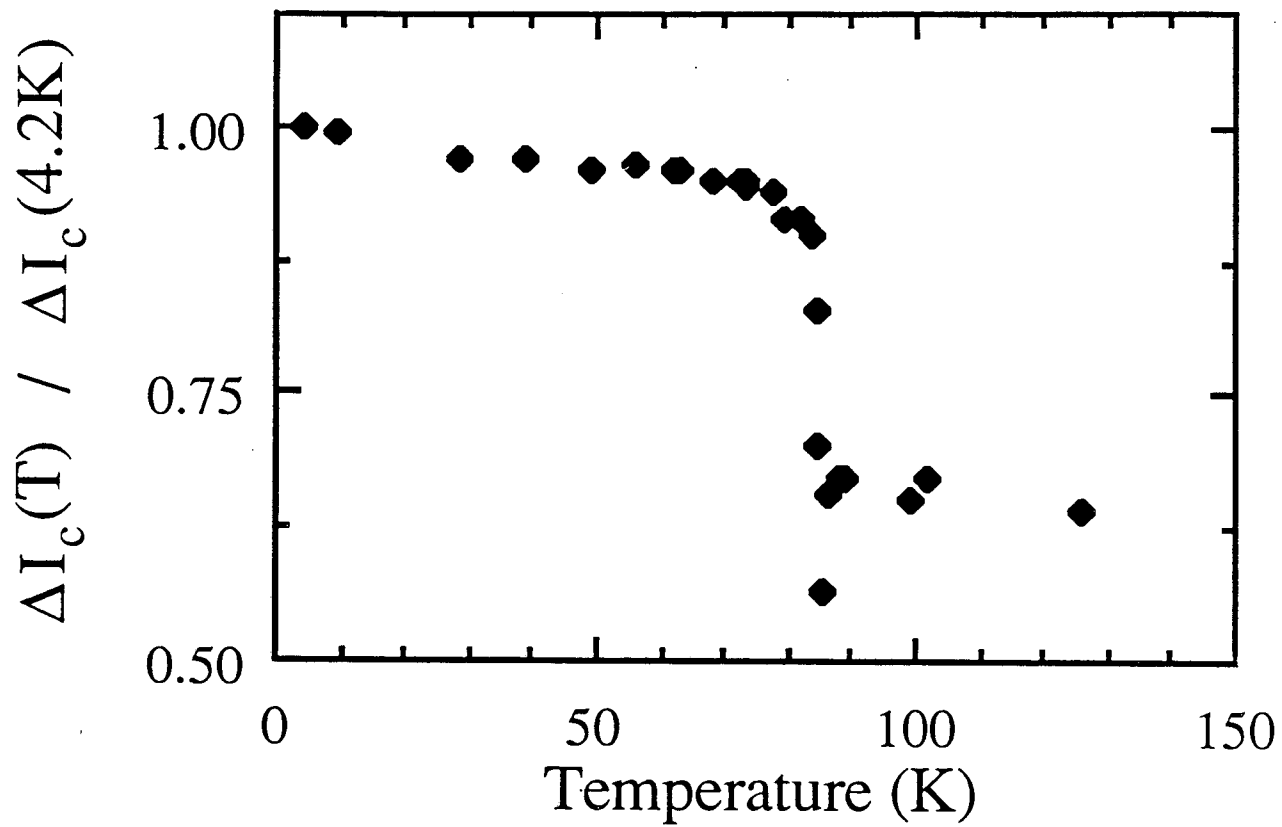

Figure 2

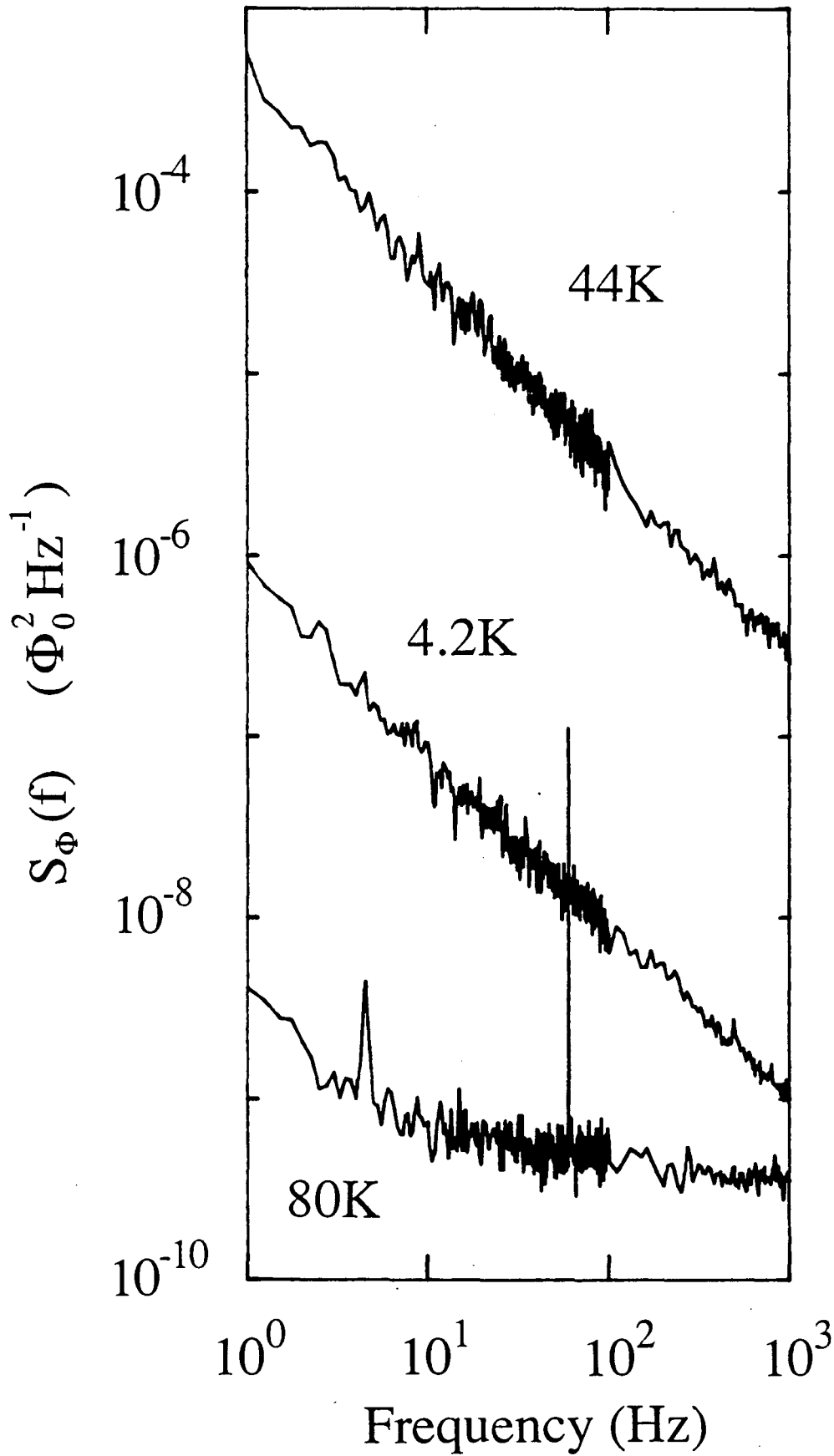

Figure 3

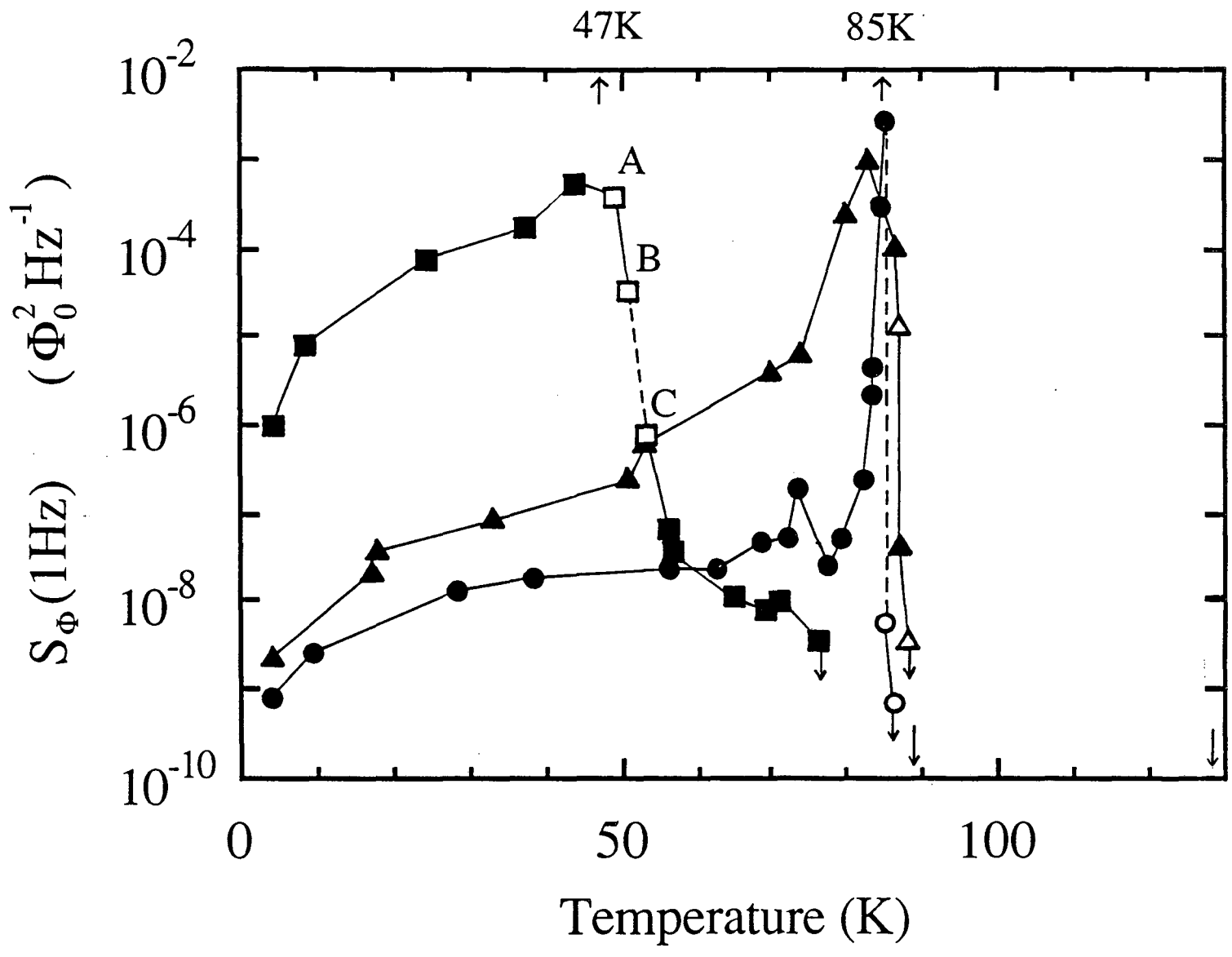

Figure 4

*LAWRENCE BERKELEY LABORATORY
TECHNICAL INFORMATION DEPARTMENT
UNIVERSITY OF CALIFORNIA
BERKELEY, CALIFORNIA 94720*