

Magnetic quivers, Higgs branches, and 6d $\mathcal{N} = (1, 0)$ theories — orthogonal and symplectic gauge groups

Santiago Cabrera,^a Amihay Hanany^a and Marcus Sperling^b

^aTheoretical Physics Group, Imperial College London,
Prince Consort Road, London, SW7 2AZ, U.K.

^bYau Mathematical Sciences Center, Tsinghua University,
Haidian District, Beijing, 100084, China

E-mail: santiago.cabrera13@imperial.ac.uk, a.hanany@imperial.ac.uk,
marcus.sperling@univie.ac.at

ABSTRACT: M5 branes on a D -type ALE singularity display various phenomena that introduce additional massless degrees of freedom. The M5 branes are known to fractionate on a D -type singularity. Whenever two fractional M5 branes coincide, tensionless strings arise. Therefore, these systems do not admit a low-energy Lagrangian description. Focusing on the 6-dimensional $\mathcal{N} = (1, 0)$ world-volume theories on the M5 branes, the vacuum moduli space has two branches where either the scalar fields in the tensor multiplet or the scalars in the hypermultiplets acquire a non-trivial vacuum expectation value. As suggested in previous work, the Higgs branch may change drastically whenever a BPS-string becomes tensionless. Recently, *magnetic quivers* have been introduced with the aim to capture all Higgs branches over any point of the tensor branch. In this paper, the formalism is extended to Type IIA brane configurations involving O6 planes. Since the 6d $\mathcal{N} = (1, 0)$ theories are composed of orthosymplectic gauge groups, the derivation rules for the magnetic quiver in the presence of O6 planes have to be conjectured. This is achieved by analysing the 6d theories for a single M5 brane on a D -type singularity and deriving the magnetic quivers for the finite and infinite gauge coupling Higgs branch from a brane configuration. The validity of the proposed derivation rules is underpinned by deriving the associated Hasse diagram. For multiple M5 branes, the approach of this paper provides magnetic quivers for all Higgs branches over any point of the tensor branch. In particular, an interesting infinite gauge coupling transition is found that is related to the $SO(8)$ non-Higgsable cluster.

KEYWORDS: Brane Dynamics in Gauge Theories, D-branes, Extended Supersymmetry, Supersymmetric Gauge Theory

ARXIV EPRINT: [1912.02773](https://arxiv.org/abs/1912.02773)

Contents

1	Introduction	1
2	Magnetic quiver	4
2.1	Set-up	4
2.2	Electric and magnetic quiver	5
2.3	Single M5 on a D-type singularity	8
2.3.1	Minimal case $k = 4$	8
2.3.2	Generic case $k > 4$	11
2.4	Multiple M5s on D-type singularity	14
2.5	Derivation rules	24
2.6	Phase diagram	26
3	Hasse diagram	28
3.1	From brane configuration	29
3.2	From quiver subtraction	33
4	Conclusions and outlook	35
A	Background material	38
A.1	Brane creation and annihilation	38
A.2	Global symmetry for orthosymplectic quiver	39

1 Introduction

Starting from the 6-dimensional $\mathcal{N} = (2, 0)$ world-volume theories living on a stack of M5 branes [1, 2], the 6-dimensional theories derived from M5 branes in various settings have been studied intensively, but many aspects still remain mysterious. One of the simplest classes of 6-dimensional $\mathcal{N} = (1, 0)$ theories is obtained from multiple M5 branes transverse to $\mathbb{R} \times \mathbb{C}^2/\Gamma$ with $\Gamma = \mathbb{Z}_k$ or \mathbb{D}_{k-2} , i.e. the A or D-type singularities. The main advantage of this class is the existence of a dual Type IIA construction via D6-D8-NS5 brane configurations with or without O6 orientifolds [3–6]. These brane constructions pointed towards the existence of non-trivial conformal fixed-points at the origin of the tensor branch, where all NS5 branes become coincident. A classification for more general 6d $\mathcal{N} = (1, 0)$ superconformal theories obtainable from F-theory compactifications has been proposed in [7, 8].

A 6-dimensional $\mathcal{N} = (1, 0)$ supersymmetric theory has massless degrees of freedom encoded in three types of supermultiplets — tensor multiplet, vector multiplet, and hypermultiplet — as well as other degrees of freedom which arise from tensionless strings [1].

For consistence, the gravitational anomaly cancellation [9] for a 6d $\mathcal{N} = (1, 0)$ theory requires [10, 11]

$$n_h + 29n_t - n_v = \text{constant} , \tag{1.1}$$

where n_t, n_v, n_h denote the numbers of tensor, vector, and hypermultiplets, respectively. In general, anomalies in 6-dimensional $\mathcal{N} = (1, 0)$ theories have been studied in works like [12–14].

In contrast to lower dimensional theories, the gauge coupling in 6 dimensions is not a mere parameter, but inversely proportional to the vacuum expectation value of the scalar field in the tensor multiplet. Moreover, the inverse gauge coupling serves as tension for BPS-strings, and is given by the distance of NS5 branes in the Type IIA realisation. On a generic point of the tensor branch, i.e. a point in which all gauge couplings are finite, the Higgs branch moduli spaces is a hyper-Kähler quotient realised by the vanishing locus of the F and D-terms modulo gauge equivalence [15]. Whenever one gauge coupling approaches infinity, i.e. at a singular locus of the tensor branch, certain BPS-strings become tensionless and new massless degrees of freedom contribute to the Higgs branch. Due to the amount of supersymmetry, the Higgs branches over tensor branch singularities are still hyper-Kähler, but generically not hyper-Kähler quotients anymore. For instance, the jump in the dimension between the Higgs branch over a generic point and the Higgs branch at the origin of the tensor branch has been computed in [16]. This indicates a non-trivial change in the Higgs branch along the tensor branch. Therefore, alternative descriptions are desirable to capture the changes of the Higgs branch geometry. Fortunately, Coulomb branches of 3-dimensional $\mathcal{N} = 4$ gauge theories are a most suitable class of hyper-Kähler moduli spaces, as detailed extensively in [17]. More generally, Higgs branches of theories with 8 supercharges can be enlarged at the UV fixed point due to massless BPS-objects, and the classical hyper-Kähler description breaks down. For instance, Coulomb branches have already been employed successfully to describe Higgs branches of Argyres-Douglas theories [18], as well as infinite coupling limits of 5-dimensional theories [19–21] and of 6-dimensional gauge theories [17, 22–24]. In fact, by interpreting these moduli spaces as symplectic singularities [25], the *magnetic quiver* techniques allowed to derive the Hasse diagrams for the various Higgs branches [26].

In this paper, the focus is placed on a class of 6d $\mathcal{N} = (1, 0)$ supersymmetric gauge theories that originate from multiple M5 branes on a D -type ALE singularity. As shown in [27], new massless tensor multiplets appear once the M5 branes reach the fixed point of the ALE space $\mathbb{C}^2/\mathbb{D}_{k-2}$. In other words, an M5 brane fractionates into two parts on the singularity; a phenomenon, known as NS5 branes splitting into two half NS5s on an O6 orientifold plane [28]. The associated class of 6d $\mathcal{N} = (1, 0)$ theories has been studied extensively [3–5, 7, 27, 29–32]; interestingly, the Higgs branches at the origin of the tensor branch have only been addressed in [16, 23, 33] recently. For a single M5 brane on $\mathbb{C}^2/\mathbb{D}_{k-2}$, the Higgs branch dimension jumps by 29 quaternionic units between a generic point and the origin of the tensor branch [16]. In [23] this phenomenon has been identified with the *small E_8 instanton transition* [34], see also [3, 29, 30, 35]. For n M5 branes on $\mathbb{C}^2/\mathbb{D}_{k-2}$, the Higgs branch dimension jumps by $n + \dim \text{SO}(8)$ quaternionic units between a generic

point and the origin [16]. In [23] a description for the Higgs branch at the CFT point has been conjectured, but a more detailed analysis is still missing.

The common reason behind the, perhaps surprising, feature that the Higgs branches change discontinuously over tensor branch lies in BPS-strings becoming tensionless. As put forward in [17] (see also [16]), the different singular loci of the tensor branch can be associated with different subsets of order parameters being zero. Here, the inverse gauge couplings $\frac{1}{g_i}$ serve as suitable order parameters for the Higgs branch phases \mathcal{P}_i of a given 6d $\mathcal{N} = (1, 0)$ theory. A unified analysis of the Higgs branch phases is possible by changing the phase of the Type IIA D6-D8-NS5 brane configuration to the phase where all (as many as possible) D6 branes are suspended between D8 branes instead of NS5 branes. This is quite intuitive, because Higgs branch degrees of freedom are read off from D6 branes suspended between D8 branes. This brane system phase enables one to systematically read off an associated *magnetic quiver* $\mathcal{Q}(\mathcal{P}_i)$ such that its data considered as defining a 3d $\mathcal{N} = 4$ Coulomb branch correctly describes the 6d $\mathcal{N} = (1, 0)$ Higgs branch of the point (phase) \mathcal{P}_i of the tensor branch, i.e.

$$\mathcal{H}^{6d}(\text{phase } \mathcal{P}_i) = \mathcal{C}^{3d} \left(\begin{matrix} \text{magnetic} \\ \text{quiver} \end{matrix} \mathcal{Q}(\mathcal{P}_i) \right) \tag{1.2}$$

holds as *equality of moduli spaces*.

The key technique [17] for achieving (1.2) is to generalise the notion of *electric* and *magnetic theory* from the Type IIB construction [36] of 3d $\mathcal{N} = 4$ world-volume theories from D3-D5-NS5 branes. Since the Type IIA system of D6-D8-NS5 branes (with or without O6 planes) is T-dual to the Type IIB configuration of D3-D5-NS5 branes (with or without O3 planes), the magnetic quiver is derived from the possible ways virtual D4 branes can be suspend between D6, D8, and NS5 branes. Again, this is in complete analogy to D-string in the Type IIB D3-D5-NS5 systems. The main purpose of this paper is to develop the formalism of magnetic quivers for 6d $\mathcal{N} = (1, 0)$ theories with orthosymplectic gauge nodes. Therefore, the inclusion of O6 orientifold planes is of central importance and one needs to suitably generalise O3 plane arguments of [37].

The proposed formalism, as extension of [17], is heavily based on various 3d $\mathcal{N} = 4$ Coulomb branch techniques developed after the Coulomb branch realisation as *space of dressed monopole operators* [38]. Relevant techniques include Kraft-Procesi transitions and transverse slices [23, 39, 40], quiver subtraction [41], and discrete quotients [24, 42, 43].

The outline of the paper is as follows: after introducing the set-up in section 2.1, the concept of a *magnetic quiver* is detailed in section 2.2. Thereafter, the cases of one M5 and multiple M5s transverse to a $\mathbb{R} \times \mathbb{C}^2/\mathbb{D}_{k-2}$ are focused on in sections 2.3 and 2.4. In particular, the derivations of the *magnetic quivers* and the geometry of the transitions of the different Higgs branches are elaborated. In section 3 the geometry of the finite and infinite coupling Higgs branch of a single M5 is explored via Kraft-Procesi transitions; moreover, the corresponding Hasse diagrams are derived. Lastly, section 4 provides a conclusion and outlook. Appendix A.1 summarises details of O6 planes, and appendix A.2 reviews Coulomb branch symmetries of 3d $\mathcal{N} = 4$ orthosymplectic quiver gauge theories.

M-theory	x^0	x^1	x^2	x^3	x^4	x^5	x^6	x^7	x^8	x^9	x^{10}
M5	×	×	×	×	×	×					
$\mathbb{C}^2/\mathbb{D}_{k-2}$	×	×	×	×	×	×	×				
Type IIA	x^0	x^1	x^2	x^3	x^4	x^5	x^6	x^7	x^8	x^9	
NS5	×	×	×	×	×	×					
D8	×	×	×	×	×	×		×	×	×	
D6, O6	×	×	×	×	×	×	×				
F1	×			×							
D4	×			×	×	×		×			

Table 1. Upper part: occupation of space-time directions by M5, and D_k singularity in M-theory. Lower part: occupation of space-time directions by NS5, D8, D6, and O6 in Type IIA. The fundamental string F1 and the D4 branes are virtual objects which are used to read off the electric and magnetic quivers.

2 Magnetic quiver

2.1 Set-up

Consider M5 branes and a D_k ALE singularity $\mathbb{C}^2/\mathbb{D}_{k-2}$ stretching the space-time dimensions as indicated in table 1. Here \mathbb{D}_{k-2} denotes the *binary dihedral group* of order $4k - 8$ such that the crepant resolution of $\mathbb{C}^2/\mathbb{D}_{k-2}$ has associated Dynkin diagram \widehat{D}_k . The singularity at the origin of $\mathbb{C}^2/\mathbb{D}_{k-2}$ is localized in directions x^7, x^8, x^9 , and x^{10} , and spans directions x^0, x^1, \dots, x^6 . Therefore, it is represented as a horizontal line. The M-theory picture can be presented as

$$\begin{array}{c}
 \times \text{M5} \quad \times \\
 \times \text{---} \times \text{---} \times \text{---} \times \text{---} \times \\
 D_k
 \end{array}
 \quad
 \begin{array}{c}
 x^{7,8,9,10} \\
 \uparrow \\
 \times \text{---} \times \\
 x^6
 \end{array}
 \tag{2.1}$$

The corresponding description in Type IIA is obtained by an identification as follows: the NS5 originates from the M5 which is point-like in the x^{10} direction. The D_k ALE space $\mathbb{C}^2/\mathbb{D}_{k-2}$ in M-theory provides a local description of k coincident D6 branes on an $O6^-$ orientifold in Type IIA on flat space. In particular, the directions x^7, x^8, \dots, x^{10} , in which the singular origin of the ALE singularity is localised in, become the three directions transverse to the D6s and the direction of the M-theory circle.

An important phenomenon is that M5 branes fractionate on ALE-singularities [27]. While for A-type singularities the number of fractions is just one, the M5 splits into two fractions on D-type orbifolds. Hence, n M5 on the D-type orbifold correspond to n pairs of two half NS5 branes in the dual Type IIA description. (The splitting of a full NS5 brane into two half NS5 branes along an O6 plane in Type IIA had already been observed earlier

in [28].) The corresponding Type IIA diagram for (2.1) is:

and the numbers displayed count full D6 branes. Note that the O6 orientifolds change whenever they cross a half NS5 or half D8 brane as summarised in appendix A.1. Moreover, the different numbers of D6 branes follow from the charges of the orientifolds and the charge conservation.

2.2 Electric and magnetic quiver

In the study of the Higgs branches of 6d $\mathcal{N} = (1, 0)$ theories resulting from M5 branes on an A-type singularity $\mathbb{C}^2/\mathbb{Z}_k$, the concept of magnetic quivers has been introduced in [17]. In this section, this concept is reviewed and extended for the application of D-type singularities.

To begin with, recall the D3-D5-NS5 brane configurations of [36] supplemented by orientifold 3-planes [37], which yield 3d $\mathcal{N} = 4$ world-volume theories with alternating orthogonal and symplectic gauge groups. Table 2 provides an overview of the set-up. In this scenario, there exists a natural notion of *electric* and *magnetic* gauge theory. D3 branes suspended between NS5 branes give rise to the electric gauge theory on their world-volume and the low-energy degrees of freedom are deduced from suspended fundamental strings. Adding D5 branes introduces electric hypermultiplets. Conversely, D3 branes in between D5 branes lead to a magnetic gauge theory on the D3 world-volume and it is the D-string that induces the relevant degrees of freedom. Consequently, NS5 branes are responsible for magnetic hypermultiplets.

The effect of O3 planes lies in a projection that reduces unitary gauge and flavour symmetries to orthogonal and symplectic symmetries, see table 3 for an overview. The characteristic sign of the low-energy effective theories is a quiver gauge theory with alternating orthogonal and symplectic gauge nodes.

By virtue of S-duality or 3d mirror symmetry [44], the maximal branches of the moduli spaces of electric and magnetic theory are related via

$$\mathcal{H}^{3d}(\text{electric theory}) = \mathcal{C}^{3d}(\text{magnetic theory}) . \quad (2.3)$$

Nevertheless, 3d mirror symmetry is a full-fledged IR-duality between the electric and magnetic theory, but for the purposes of this paper relations of the type (2.3) are the central objective.

Returning to the D6-D8-NS5 brane configurations [3, 4] supplemented by orientifold 6-planes, a central point in the argument of [17] is that the system is T-dual to the D3-D5-NS5 system upon three T-dualities along x^3, x^4, x^5 . The conventional quiver gauge theory on a generic point of the tensor branch of the 6d $\mathcal{N} = (1, 0)$ theory is read off

Type IIB	x^0	x^1	x^2	x^3	x^4	x^5	x^6	x^7	x^8	x^9
NS5	×	×	×	×	×	×				
D5	×	×	×					×	×	×
D3, O3	×	×	×				×			
F1	×			×						
D1	×							×		

Table 2. Occupation of space-time directions by NS5, D5, D3, and O3 in Type IIB. The fundamental string F1 induces the electric theory, while the D-string D1 induces the magnetic theory.

orientifold	gauge group	flavour group	S-dual
$O3^-$	$O(2n)$	$USp(2k)$	$O3^-$
$\widetilde{O3}^-$	$O(2n+1)$	$USp(2k)$	$O3^+$
$O3^+$	$USp(2n)$	$O(2k)$ or $O(2k+1)$	$\widetilde{O3}^-$
$\widetilde{O3}^+$	$USp'(2n)$	$O(2k)$ or $O(2k+1)$	$\widetilde{O3}^+$

Table 3. Effect of O3 orientifolds on the low-energy effective theories. A stack of n full D3 branes and an O3 plane suspended between two NS5 branes gives rise to the electric gauge group. Moreover, if there are $2k$ half D5 branes, or in the case of $O3^+$ and $\widetilde{O3}^+$ there may also be $2k+1$ half D5s, intersecting the D3-O3 stack then an electric flavour group arises. Lastly, S-duality transforms the O3 planes among each other and the resulting magnetic gauge groups are the GNO duals [45] of the electric gauge groups.

from the phase of the Type IIA brane configuration in which all NS5 branes are well separated along the orientifold. The effect of the O6 orientifold planes is analogous to the 3d setting and is summarised in the left-hand-side of table 4 for convenience. The condition for an anomaly-free 6d theory is equivalent to charge conservation in the Type IIA brane configuration [3, 4], see also appendix A.1 and [13] for 6d anomaly-free theories. This type of quiver gauge theory is denoted as *electric theory* in the remainder of this paper.

In p -dimensional world-volume theories (with 8 supercharges) originating from Dp - $D(p+2)$ -NS5 brane configurations, the Higgs branch degrees of freedom are associated with freely moving Dp branes suspended between $D(p+2)$ branes. As such, the proposal of [17] is to employ this phase of the brane configuration to read off a *magnetic quiver*, such that

$$\mathcal{H}^{pd}(\text{electric theory}) = \mathcal{C}^{3d}(\text{magnetic theory}) \tag{2.4}$$

holds as an *equality of moduli spaces*.

Inspired from 3d mirror symmetry, the magnetic degrees of freedom are associated to the suspension pattern of D4 branes in the D6-D8-NS5 configuration, because following the three T-dualities of the D1 branes in Type IIB precisely lead to D4 branes in Type IIA. A major difference in the magnetic quiver of the D6-D8-NS5 system compared to the D3-D5-NS5 system is the role played by the NS5 branes. Since the NS5s and the D6s

orientifold	electric group	magnetic orientifold	magnetic algebra
$O6^-$	$SO(2n)$	$O6^-$	\mathfrak{d}_n
$\widetilde{O6}^-$	$SO(2n+1)$	$O6^+$	\mathfrak{c}_n
$O6^+$	$USp(2n)$	$\widetilde{O6}^-$	\mathfrak{b}_n
$\widetilde{O6}^+$	$USp'(2n)$	$\widetilde{O6}^+$	\mathfrak{c}_n

Table 4. The two left columns display low-energy gauge group of a stack of n physical D6 branes on top of an O6 plane, all suspended in between NS5 branes. The two columns on the right-hand-side display the proposed magnetic orientifold to read off the magnetic gauge algebra of a stack of n physical D6 on top of an magnetic orientifold, all suspended between D8 branes.

suspended between D8 branes both share a 6-dimensional world-volume, the NS5 branes contribute as magnetic gauge degrees of freedom as opposed to flavour degrees of freedom.

The inclusion of O6 planes presents a major conceptual challenge in the derivation of the associated magnetic quivers. That is because (2.3) for systems with O3 planes involves S-duality of the orientifold 3-planes, and there is no S-duality in Type IIA. To overcome this obstacle, one recalls the logic of [17] for A-type singularities (see also [23] for D-type): the magnetic quiver associated to the conventional electric quiver gauge theory in the finite coupling phase is essentially given by 3d mirror symmetry, up to taking care of anomalous U(1) gauge nodes in transition 6d to 3d and back. The point of [17] is to promote the Higgs branch phase or magnetic phase, i.e. Dp branes suspended between $D(p+2)$, and the associated quiver theories as valid moduli space description at *any* value of the electric gauge coupling. Therefore, inspired from 3d mirror symmetry of orientifolds [37], the proposed prescription to read off the magnetic quiver is as follows:

- (i) Change the brane system to the phase where as many D6 branes are suspended between D8 branes as possible.
- (ii) Change the physical (electric) orientifolds to virtual *magnetic orientifolds*, which follow the logic of GNO or Langlands duality. These are summarised in table 4.

The main point of this paper is to extend the techniques of [17] to the study of 6d $\mathcal{N} = (1, 0)$ Higgs branches originating from n M5 branes on a D_k singularity $\mathbb{C}^2/\mathbb{D}_{k-2}$.

Notation. In the remainder, the notation is adjusted to differentiate electric and magnetic quivers, as well as to accommodate for known subtleties. The gauge nodes in the relevant electric theories are denoted by $SO(2k)$ and $Sp(k)$. For the magnetic quiver, only the gauge algebra are detailed, i.e. \mathfrak{b}_k , \mathfrak{c}_k , or \mathfrak{d}_k . This is partly due to known issues about magnetic theories with orthogonal gauge groups. For example, in $T^\rho(G)$ theories [46–48] with G of type B , C , or D , there exists several possible quivers for a single partition ρ . The corresponding Coulomb branches differ by projections of certain discrete groups and the correct identification of the required quotient is subtle [49].

2.3 Single M5 on a D-type singularity

Consider a single M5 brane transverse to $\mathbb{R} \times \mathbb{C}^2/\mathbb{D}_{k-2}$ for $k \geq 4$. For the dual Type IIA description, see table 1, one recalls

$$\begin{array}{c} k \qquad k-4 \qquad k \\ \hline \bigotimes \cdots \bigotimes \\ \hline \end{array} \quad (2.5)$$

and the conventions on O6 planes are summarised in appendix A.1. The low-energy effective 6d $\mathcal{N} = (1, 0)$ theory [3–5, 27, 29–32] contains a single tensor multiplet as well as hyper and vector multiplets encoded in the following electric quiver

$$\begin{array}{c} \text{SO}(4k) \\ \square \\ | \\ \circ \\ \text{Sp}(k-4) \end{array} \quad (2.6)$$

and the interest is placed on the moduli space of vacua. For completeness, there exists one decoupled tensor multiplet, which can be neglected for the purposes of this paper. Since there exists only one non-decoupled tensor multiplet, the interesting part of the tensor branch is effectively $\mathbb{R}_{\geq 0}$, which exhibits a singularity at the origin. Therefore, the objective is to study two spaces:

- (i) The Higgs branch $\mathcal{H}_{\text{fin}}^{6\text{d}}$ of the theory over a generic point of the tensor branch, i.e. one tensor multiplet together with the gauge theory (2.6) at finite gauge coupling.
- (ii) The Higgs branch $\mathcal{H}_{\infty}^{6\text{d}}$ over the origin of the tensor branch, i.e. no tensor multiplets, but the quiver theory (2.6) at infinite coupling.

Physically, whenever a gauge coupling diverges, certain BPS-strings become tensionless and contribute to the massless degrees of freedom. As, for instance, detailed in [23], these originate from D2 branes stretched between the half NS5 branes in the brane configuration (2.5). Since the D2s are codimension 4 objects for the D6 branes, they are gauge instantons with corresponding zero-modes. The quantised zero-modes have been argued to finitely generate all massless degrees of freedom stemming from the tensionless BPS-strings. Consequently, there exists a natural inclusion of moduli spaces

$$\mathcal{H}_{\text{fin}}^{6\text{d}} \subset \mathcal{H}_{\infty}^{6\text{d}} \quad (2.7)$$

because $\mathcal{H}_{\infty}^{6\text{d}}$ is generated by all classical Higgs branch generators of $\mathcal{H}_{\text{fin}}^{6\text{d}}$ plus the additional generators for the massless string modes.

In this section, the transition between $\mathcal{H}_{\text{fin}}^{6\text{d}}$ and $\mathcal{H}_{\infty}^{6\text{d}}$ as well as their geometry is derived from a brane construction.

2.3.1 Minimal case $k = 4$

For $k = 4$, the electric gauge theory (2.6) is trivial as well as the Higgs branch at finite gauge coupling. As a warm up, one begins by studying how the trivial finite coupling phase manifests itself in the magnetic phase.

Finite coupling. Starting from (2.5) one moves to the phase of the brane system where all D6 are suspended between D8; therefore, from $x^6 = \pm\infty$ one pulls in $2k$ half D8 each.

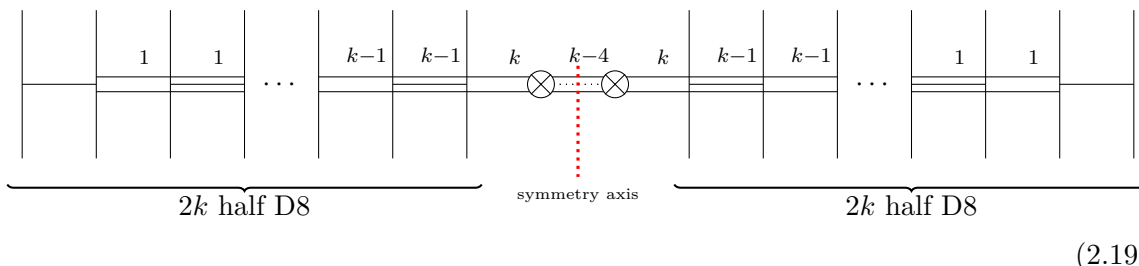

To reach the phase of finite gauge coupling, the D6 branes have to be suspended purely between D8 branes without the half NS5s leaving the orientifold plane. Since the set-up is symmetric along the x^6 direction (see red dotted symmetry axis), one can focus on the left-hand-side without loss of generality. Inspecting the left-hand-side of (2.19), there are k full D6 on the left and $(k-4)$ full D6 on the right of the left-most half NS5 brane. Therefore, one may consider $(k-4)$ D6 branes going through the half NS5 branes such that these D6s are really suspended between half D8 branes. The remaining 4 full D6 on the left-hand-side are considered as frozen between D8 branes and the half NS5 brane. These frozen D6 can be eliminated, without changing the physics, by passing the half NS5 through seven half D8 branes and taking care of brane annihilation (A.5). One may wonder whether to cross an additional eighth D8 brane, but it turns out that after conversion to magnetic orientifolds the correct brane configuration for the purpose of reading the magnetic quiver becomes

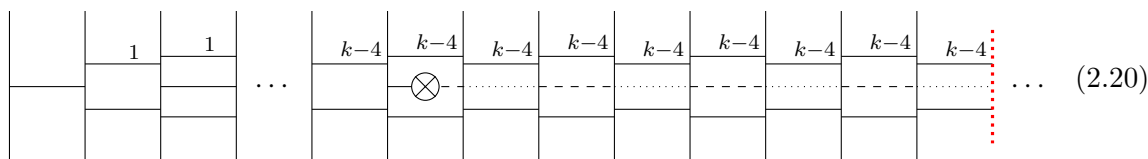

and all the D6 branes are suspended between D8 branes. The half NS5 has no D6 branes ending on it and is, moreover, stuck on the orientifold. Employing the same arguments as in the previous section — reading off gauge nodes from stacks of D6 branes on *magnetic orientifolds* of table 4 and so forth — one deduces the following magnetic quiver:

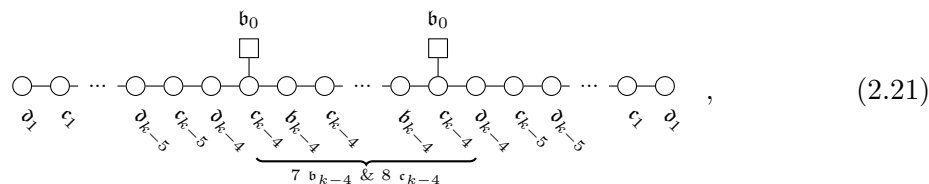

and potentially empty gauge nodes from D8 intervals with no D6 branes have been omitted. The dimension and symmetry of the Coulomb branch are computed to be

$$\dim_{\mathbb{H}} \mathcal{C}^{3d} \left(\text{magnetic quiver (2.21)} \right) = 2 \cdot \sum_{i=1}^{k-4} (\dim \mathfrak{d}_i + \dim \mathfrak{c}_i) + 7 \cdot \dim \mathfrak{b}_{k-4} + 6 \cdot \dim \mathfrak{c}_{k-4}$$

$$= \dim \text{SO}(2k) - \dim \text{SO}(8), \tag{2.22a}$$

$$G_J = \text{SO}(4k), \tag{2.22b}$$

due to a chain of $(4k-3)$ balanced nodes with \mathfrak{d}_1 nodes at each end, see appendix A.2. These properties match the classical Higgs branch of (2.6). Hence, the significance of (2.25) lies in

$$\mathcal{C}^{3d} \left(\text{magnetic quiver (2.21)} \right) = \mathcal{H}_{\text{fin}}^{6d} \left(\text{electric theory (2.6)} \right), \tag{2.23}$$

which can also be derived by taking (2.6) as a 3d $\mathcal{N} = 4$ system and computing the 3d mirror, as shown in [37, figure 13]. While the quiver (2.21) has been conjectured in [23]; here, the magnetic quiver has been *derived* from a D6-D8-NS5 brane construction with O6 planes.

Infinite coupling. Having established the magnetic phase for the finite coupling regime, one can proceed to infinite gauge coupling. Physically, infinite gauge coupling means that the two half NS5 in (2.5) or (2.19) have vanishing distance along x^6 . However, when two half NS5 branes are coincident on an O6 plane, they can leave the orientifold in transverse $x^{7,8,9}$ direction as mirror pair of half NS5 branes. The $(k-4)$ full D6 branes that had originally been suspended between the two half NS5 branes disappeared, and there are no D6 branes attached between the pair of half NS5 outside the O6 plane. However, the k full D6 branes¹ that were attached from the left and right side of the pair of NS5 branes can reconnect while the half NS5s leave the orientifold. Therefore, the brane configuration describing the infinite gauge coupling phase is reached by reuniting the two half NS5s such that they can leave the orientifold as pair of half NS5, i.e.

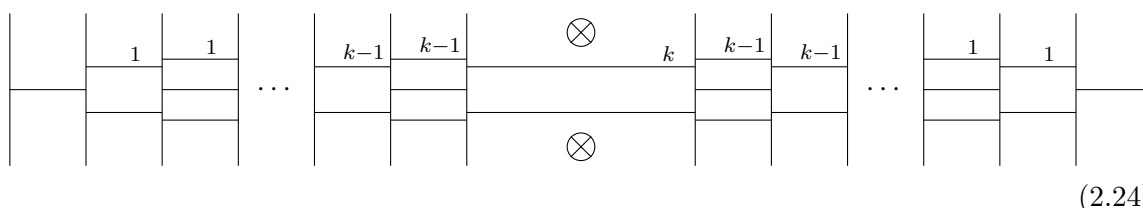

and the magnetic quiver is read off by using the orientifold conversion to *magnetic orientifolds*, cf. table 4, to be

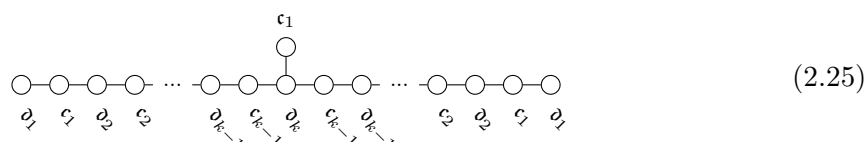

and the Coulomb branch dimension and symmetry is computed to be

$$\begin{aligned} \dim_{\mathbb{H}} \mathcal{C}^{3d} \left(\text{magnetic quiver (2.25)} \right) &= 2 \cdot \sum_{i=1}^{k-1} (\dim \mathfrak{d}_i + \dim \mathfrak{c}_i) + \dim \mathfrak{d}_k + \dim \mathfrak{c}_1 \\ &= \dim \text{SO}(2k) + 1 \end{aligned} \tag{2.26a}$$

$$\begin{aligned} &= \dim_{\mathbb{H}} \mathcal{C}^{3d} \left(\text{magnetic quiver (2.21)} \right) + 29, \\ G_J &= \text{SO}(4k). \end{aligned} \tag{2.26b}$$

¹Due to charge conservation, the numbers of D6 branes on the left and right of a pair of half NS5 branes have to be equal.

Note that the global symmetry matches the global $SO(4k)$ symmetry of (2.6), which is expected to remain the symmetry in the infinite coupling case for $k > 4$. Moreover, the Higgs branch dimension of (2.6) at infinite coupling has been computed in [16, eq. (1.2)] and agrees with (2.26). Consequently, the significance of this result lies in

$$\mathcal{C}^{3d} \left(\begin{array}{c} \text{magnetic} \\ \text{quiver} \end{array} (2.25) \right) = \mathcal{H}_{\infty}^{6d} \left(\begin{array}{c} \text{electric} \\ \text{theory} \end{array} (2.6) \right) . \tag{2.27}$$

Again, the magnetic quiver (2.25) had been conjectured in [23], but the formalism presented here allows to *derive* it from a brane configuration.

The geometric relationship between finite and infinite gauge coupling phase is the subject of section 3.

2.4 Multiple M5s on D-type singularity

Having discussed a single M5 brane on a D-type singularity, it is time to include multiple M5 branes. To be precise, consider n M5 branes on $\mathbb{C}^2/\mathbb{D}_{k-2}$ for $k \geq 4$, then the dual Type IIA description yields

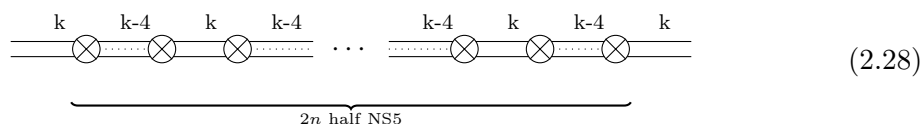

such that the resulting 6d $\mathcal{N} = (1, 0)$ theory consists of $(2n - 1)$ tensor multiplets together with hyper and $(2n - 1)$ vector multiplets encoded in the electric quiver gauge theory [3–5, 27, 29–32]

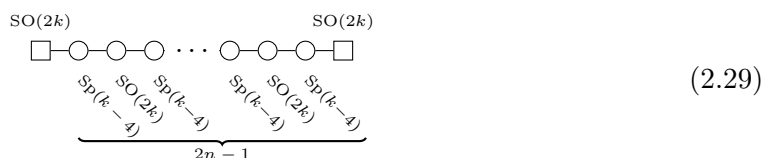

and one decoupled tensor multiplet. The vacuum moduli spaces structure is more sophisticated than in the single M5 brane case, simply because there are $(2n - 1)$ non-decoupled tensor multiplets, or, equivalently, $(2n - 1)$ independent gauge couplings in (2.29). Again, there are various singular loci where BPS-strings become tensionless and the Higgs branches of the theories over these singularities have to be investigated carefully.

- (i) The Higgs branch $\mathcal{H}_{\text{fin}}^{6d}$ over a generic point of the tensor branch, i.e. the theory has $(2n - 1)$ tensor multiplets and all couplings in the gauge theory (2.29) are finite.
- (ii) The Higgs branch $\mathcal{H}_{j, \gamma \in \sigma(j)}^{6d}$ over a singular point of order j ($1 \leq j < 2n - 1$) of the tensor branch, i.e. the theory has lost j out of the $(2n - 1)$ tensor multiplets. Note that there are multiple singular loci of the same order, meaning that there are $\sigma(j)$ different possibilities to take j out of the $(2n - 1)$ gauge couplings to infinity.
- (iii) The Higgs branch $\mathcal{H}_{\infty}^{6d}$ over the origin of the tensor branch, i.e. no tensor multiplets and all couplings in (2.29) are infinite.

The Higgs branches of the different phases as well as the transition between them are *derived* from a brane configuration in this section.

Generic point on tensor branch. The first step is to derive the magnetic quiver description for the finite coupling regime of (2.29). To achieve this, one pulls in $2k$ half D8 branes from both $x^6 = \pm\infty$ and obtains

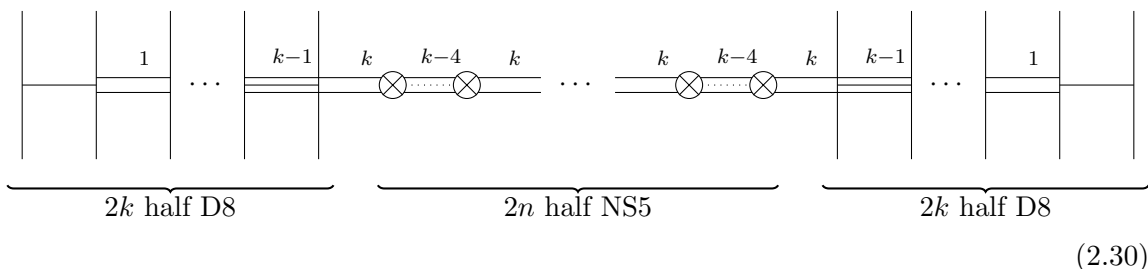

and the next step lies in suspending as many D6 branes between D8 branes as possible. Since half NS5 branes cannot leave the O6 plane in the finite coupling regime, the strategy is as follows: firstly, transition the outermost half NS5 brane through seven D8 branes. The reasoning is as in section 2.3.2, from the k full D6 branes that are suspended between one of the outer-most NS5 and a D8 brane, one can consider $(k - 4)$ of them as going through the NS5 and only 4 of them as being frozen between the NS5 and D8. Frozen branes do not contribute to the Higgs branch and can be eliminated by brane-annihilation (A.5) when the NS5 passes through half D8 branes.

Secondly, the remaining $(n - 1)$ pairs of half NS5 branes are considered as having 8 half D6 suspended between them, while the other $2(k - 4)$ half D6 branes are suspended between the pulled in D8 branes. The brane configuration looks like

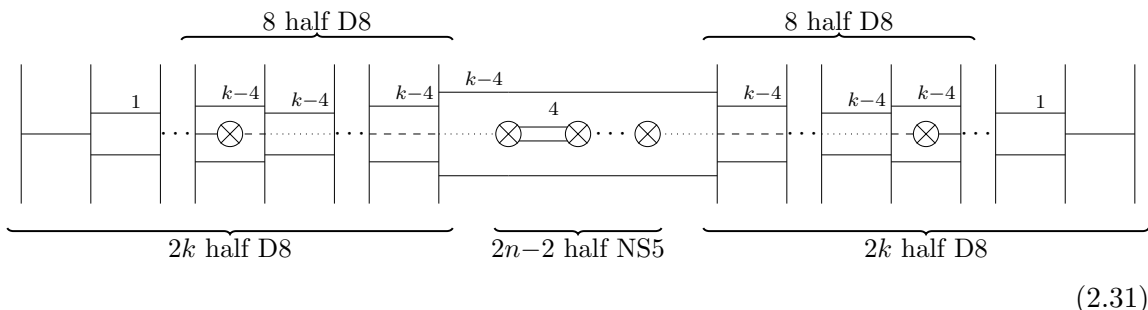

In the centre, one observes $(n - 1)$ pairs of half NS5 branes with 8 half D6 branes suspended in between, and there is no way to suspend these D6 between D8 branes. Consequently, these D6 do not contribute to the Higgs branch either and as such one considers them as contributing flavour nodes to the magnetic quiver. Employing the conversion to *magnetic orientifolds* of table 4, one reads off the magnetic quiver to be

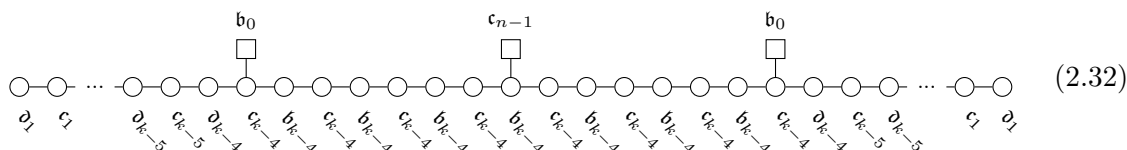

The Coulomb branch dimension of (2.32) is readily computed

$$\begin{aligned} \dim_{\mathbb{H}} \mathcal{C}^{3d} \left(\begin{array}{c} \text{magnetic} \\ \text{quiver} \end{array} (2.32) \right) &= 2 \cdot \sum_{i=1}^{k-4} (\dim \mathfrak{c}_i + \dim \mathfrak{d}_i) + 7 \cdot \dim \mathfrak{b}_{k-4} + 6 \cdot \dim \mathfrak{c}_{k-4} \\ &= \dim \text{SO}(2k) - \dim \text{SO}(8). \end{aligned} \quad (2.33)$$

To compute the Higgs branch dimension of (2.29), one needs to recall that there is no complete Higgsing of the $\text{SO}(2k)$ gauge nodes; instead, there is partial Higgsing $\text{SO}(2k) \rightarrow \text{SO}(8)$ such that one computes

$$\begin{aligned} \dim_{\mathbb{H}} \mathcal{H}_{\text{finite}}^{6d} \left(\begin{array}{c} \text{electric} \\ \text{theory} \end{array} (2.29) \right) &= n_h - n_v = \dim \text{SO}(2k) - \dim \text{SO}(8) \\ n_h &= \frac{1}{2} \cdot 2k \cdot (2k - 8) \cdot 2n \\ n_v &= n \cdot \dim(\text{Sp}(k - 4)) + (n - 1) \cdot (\dim(\text{SO}(2k)) - \dim(\text{SO}(8))), \end{aligned} \quad (2.34)$$

which is independent of n , and confirms that the Higgs branch is trivial for $k = 4$. One observes that both dimensions (2.33) and (2.34) agree. Moreover, a computation of the topological symmetry of (2.32) reveals

$$G_J = \text{SO}(2k) \times \text{SO}(2k) \quad (2.35)$$

because the central \mathfrak{b}_{k-4} node is never balanced for $k > 1$, but always a *good* in the sense of appendix A.2. The Coulomb branch symmetry agrees with that of the Higgs branch of (2.6). Therefore, the significance of this derivations is that

$$\mathcal{C}^{3d} \left(\begin{array}{c} \text{magnetic} \\ \text{quiver} \end{array} (2.32) \right) = \mathcal{H}_{\text{fin}}^{6d} \left(\begin{array}{c} \text{electric} \\ \text{theory} \end{array} (2.29) \right). \quad (2.36)$$

The challenge in computing the Higgs branch of (2.29) lies in non-complete Higgsing, and current techniques are not suitable or able to overcome the difficulties. Therefore, the magnetic quiver (2.32) provides a prediction for the Higgs branch description.

One infinite gauge coupling. Next, one can proceed to one of the infinite gauge coupling phases. As indicated above, there are $(2n - 1)$ tensor multiplets, i.e. $(2n - 1)$ different order parameters that can be tuned. Moreover, recall that tuning a gauge coupling to infinity means that the associated pair of half NS5 has to become coincident along x^6 . By charge conservation, the numbers of D6 branes on the left and right of a pair of half NS5 branes are identical, as long as no D8 branes are involved. Thus, the pair of half NS5 branes can leave the orientifold in transverse $x^{7,8,9}$ direction and the D6 branes from the left and right of the pair reconnect. As apparent from (2.31), there are two different types of pairs that can become coincident:

- (i) either a pair of half NS5 branes with 4 full D6 branes in between,
- (ii) or a pair of half NS5 branes with no D6 branes in between.

To begin with, consider the left pair of half NS5 branes with 8 half D6 branes in between as in brane configuration (2.31), then this pair can leave the O6 as explained above and

The associated magnetic quiver is read off by the same logic as before. The D6 branes suspended in intervals between half D8 branes contribute magnetic gauge nodes according to the orientifold, see table 4. The pairs of half NS5 branes on the orientifold with 4 full D6 branes suspended do contribute as flavours. In contrast, the pair of half NS5 that left the orientifold contributes as magnetic vector multiplet. To see how, one suspends virtual D4 branes between the NS5s, and observes that the magnetic orientifold of an $O6^-$ plan is again an $O6^-$, resulting in a symplectic gauge node. In addition, virtual D4 branes can be suspended between the half NS5s that left the orientifold and the D6s in between the NS5s on the orientifold. Since these D6 branes are not Higgs branch moduli, the D4 branes lead to a flavour $SO(8)$ node attached to the symplectic magnetic gauge node. Thus, the magnetic quiver associated to (2.40) becomes

(2.41)

which compared to (2.38) has the same moduli space dimension.

In fact, the physical transition from the 6d perspective appears to be identical to the first case. During the transition, the number of tensor multiplets and the number of $SO(8)$ vector multiplets are simultaneously reduced by one such that the anomaly cancellation condition (1.1) enforces the appearance of one additional hypermultiplet. As such, this confirms the observation that both types of transitions (2.37), (2.40) are one-dimensional. As a consequence, one may also consider a transition from brane configuration (2.37) to (2.40). In other words, moving a pair of half NS5 branes that left the orientifold along the x^6 direction across at least one half NS5 brane. Following the brane configuration, as well as the associated magnetic quiver, leads to the *prediction* that there is a discrete change of the Higgs branch whenever a pair of NS5 branes outside the orientifold crosses a half NS5 brane on the orientifold.

Moreover, one can go back to configuration (2.31) and consider any pair of neighbouring half NS5 branes. According to the above arguments, for any pair, the infinite gauge coupling transition for this pair is of the form

$$1 \text{ tensor} + 1 \text{ } SO(8) \text{ vector} \rightarrow 1 \text{ hyper} , \tag{2.42}$$

but the resulting magnetic quiver is either (2.38) or (2.41), depending on which pair is chosen. In total, there are exactly $(2n - 1)$ of these one-dimensional transitions. Although different gauge couplings of (2.29) are taken to infinity, the resulting moduli spaces fall into two classes, given by (2.38) or (2.41). In addition, the transition between both is physically described by a change of x^6 position of a pair of NS5 branes.

More infinite gauge couplings. Form the $(2n - 2)$ half NS5 branes in the centre of the brane configuration (2.30), one can form at most $(n - 1)$ pairs that can under-go

transition (2.42). An arbitrary intermediate stage is given by l pairs of half NS5 branes undergoing the transition (2.42), with l_0 pairs of the form (2.37) and l_1 pairs of the form (2.40) such that $l = l_0 + l_1$, and remaining separated along x^6 . For $0 \leq l \leq (n - 1)$, the resulting magnetic quiver becomes

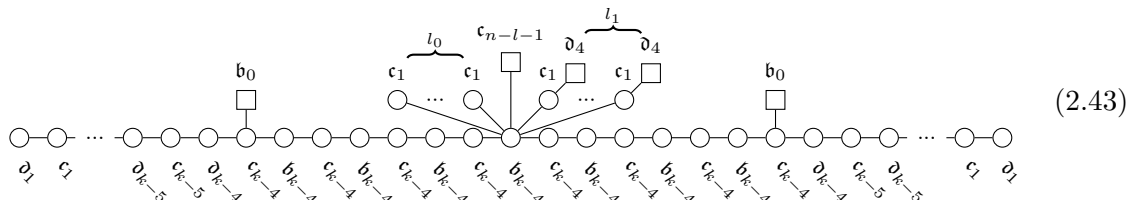

and the Coulomb branch dimension has increased by l quaternionic units in comparison to (2.32).

Discrete gauging. Consider the case in which all possible $(n - 1)$ pairs of half NS5 under-go the transition (2.42), then the brane configuration becomes

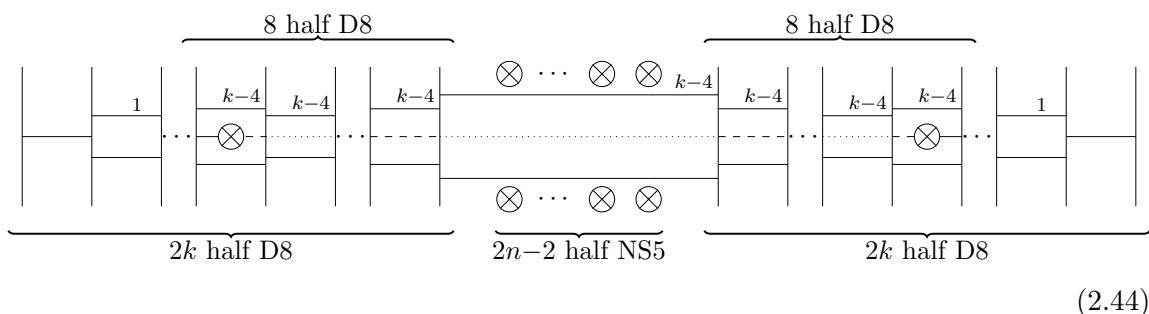

and the x^6 distance between the neighbouring pairs still corresponds to tensor multiplet, i.e. an inverse gauge coupling. By the rules establish so far, the magnetic quiver reads as follows:

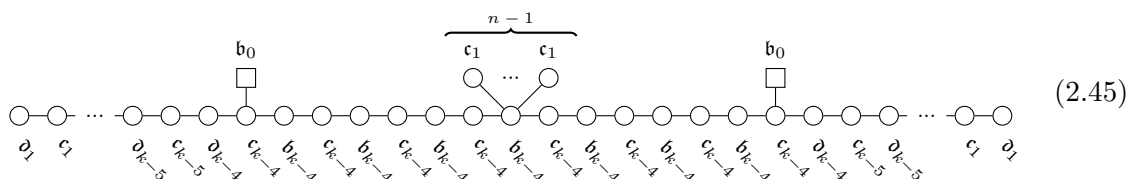

In particular, once all $(n-1)$ pairs of half NS5s in the centre of the brane configuration (2.31) have left the orientifold, there is only one type of c_1 gauge node in the magnetic quiver.

Focusing on two neighbouring pairs, one could suspend half D2 branes between the half NS5 branes. Sending the x^6 distance to zero creates tensionless strings on the D2s. The analogous effect for M5 branes on an A-type singularity has been considered in [24] and argued to be a *discrete gauging* of a permutation group acting on the (pairs of) NS5 branes. Here, the argument applies to n mirror pairs of NS5s in the presence an O6 plane. The possibilities for the pairs to become coincident along x^6 are labeled by partitions $\{n_i\}_{i=1,\dots,l}$ of $(n - 1)$, meaning that n_i of all pairs coincide in definite x^6 position and so on and so

Likewise, one may consider discrete gauging in the phase (2.43). Without loss of generality, one can assume that all pairs of NS5 branes that underwent transition (2.37) (or (2.40)) are in the same x^6 interval defined by two half NS5 on the orientifold. Then, one can consider either family of NS5 pairs becoming coincident along x^6 , i.e. discrete gauging. For the pure \mathfrak{c}_1 bouquet of size l_0 , the resulting effects is the same as above due to [42, section 2.2]. For the $(\mathfrak{c}_1 \circ -\square\mathfrak{d}_4)$ bouquet of size l_1 , the discrete quotient effect on the magnetic quiver is a straightforward extension of [42, section 2.2], i.e. one obtains an \mathfrak{c}_1 gauge node with a \mathfrak{d}_4 flavour node and an additional traceless 2nd rank anti-symmetric hypermultiplet.

Small instanton transition. Return to the brane configuration (2.44), and consider how to take the separation of the two half NS5s that remain on the orientifold to zero. This is the next logical question, because by the previous paragraphs one knows how to take all other gauge couplings to infinity. In order to take the last remaining gauge coupling to infinity, one has to reunite the remaining two NS5 on the orientifold and then remove them from the O6 plane. By transitioning the two outermost half NS5 branes through the half D8 branes, one creates D6 branes according to rules in (A.5). At the instance during which the NS5 become coincident and leave the O6 plane, the D6 brane reconnect such that the resulting brane configurations becomes

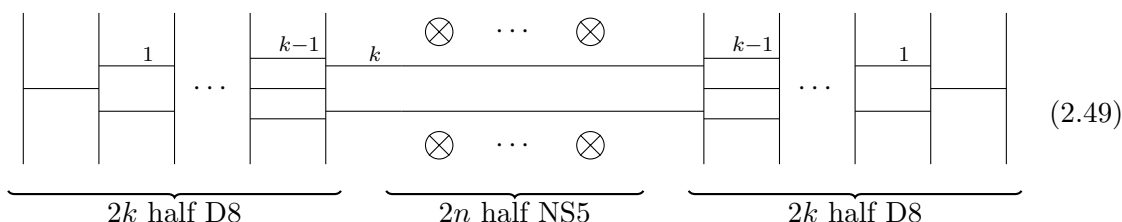

and, here, all NS5 pairs are separated along x^6 . By the arguments presented above, the magnetic quiver for (2.49) is readily read off to be

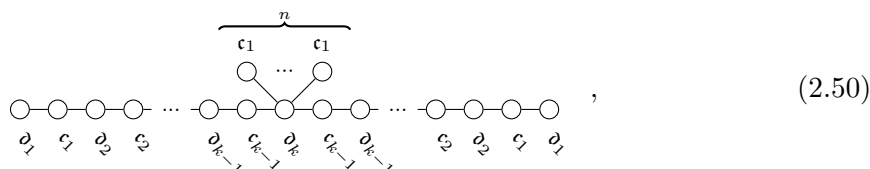

and its Coulomb branch describes a Higgs branch phase of (2.29) with n gauge couplings tuned to infinity.

The nature of this last transition can be deduced in multiple ways. On the one hand, the starting point (2.44) describes one remaining M5 that fractionated on the D-type singularity. Taking it off the singularity corresponds to the small E_8 instanton transition as discussed above. Put differently, before the transition there existed one extra tensor multiplet, which is lost afterwards. Since the number of vector multiplets has not changed, there need to be 29 additional hypermultiplets to satisfy (1.1). On the other hand, one can apply quiver subtraction to (2.50) and (2.43) and deduce that the difference quiver is precisely (2.14). As detailed in section 3, the transverse slice of the Coulomb branch of (2.43) inside the Coulomb branch of (2.50) is the closure of the minimal nilpotent orbit of E_8 .

As discussed above, the x^6 separation between the pairs of NS5 branes in (2.49) corresponds to tensor multiplets. The possibilities of taking different subsets of gauge couplings to infinity are, again, labeled by partitions $\{n_i\}_{i=1,\dots,l}$ of n , meaning n_i pairs of half NS5 brane coincide along x^6 , with $\sum_{i=1}^l n_i = n$.

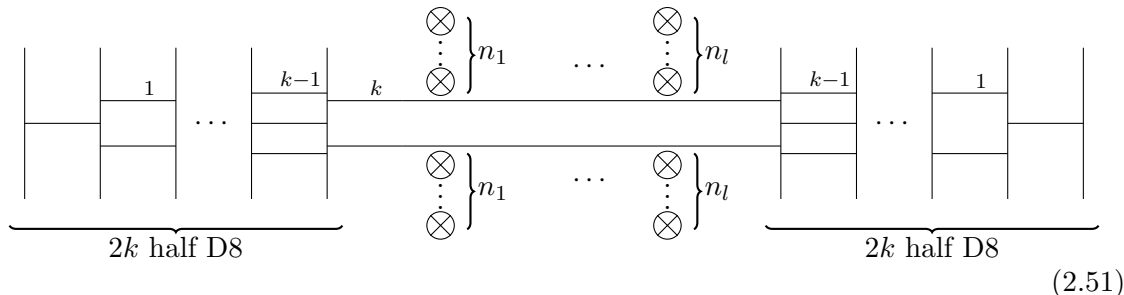

The logic is the same as in (2.47). Therefore, the magnetic quiver becomes

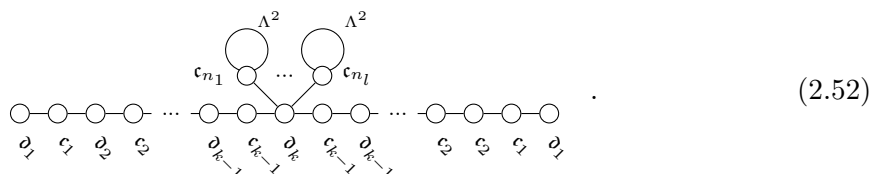

It is important to recall that the Coulomb branch of (2.52) describes a Higgs branch phase where $(2n - l)$ gauge couplings are tuned to infinity. According to [42, section 2.2], the moduli spaces are related via

$$\mathcal{C}^{3d} \left(\text{magnetic quiver (2.52)} \right) = \mathcal{C}^{3d} \left(\text{magnetic quiver (2.50)} \right) / \prod_i S_{n_i}. \quad (2.53)$$

Physically, there exists a discrete S_n action, or of its subgroups, on the pairs of half NS5 branes, which is gauged when all pairs become coincident.

The Coulomb branch symmetry of (2.52) is

$$G_J = \text{SO}(2k) \times \text{SO}(2k) \quad (2.54)$$

because the central \mathfrak{d}_k nodes is always *good*, but never balanced for $n > 1$. This symmetry agrees with the Higgs branch symmetry of (2.29) at the origin of the tensor branch. In addition, there is discrete Coulomb branch symmetry factor which corresponds to the symmetry of the magnetic quiver. Next, the Coulomb branch dimension of (2.52) is readily computed

$$\begin{aligned} \dim_{\mathbb{H}} \mathcal{C}^{3d} \left(\text{magnetic quiver (2.52)} \right) &= 2 \cdot \sum_{i=1}^{k-1} (\dim \mathfrak{c}_i + \dim \mathfrak{d}_i) + \dim \mathfrak{d}_k + \sum_{i=1}^l \dim \mathfrak{c}_{n_i} \\ &= n + \dim \text{SO}(2k). \end{aligned} \quad (2.55)$$

Origin of tensor branch. Lastly, the origin of the tensor branch is reached when all half NS5s have left the orientifold pairwise and all pairs are coincident; hence, partition $\{n\}$ and the brane configuration becomes

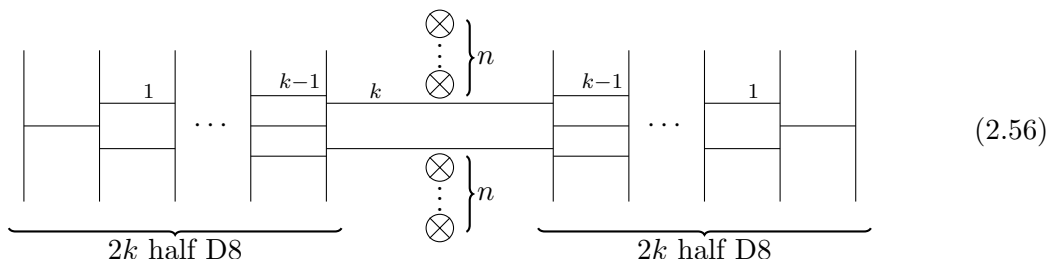

such that the corresponding magnetic quiver, using table 4, is read off to be

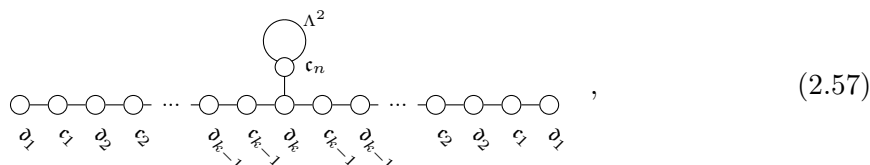

which had been *conjectured* in [23] as a description for the Higgs branch at infinite coupling. Here, the magnetic quiver has been *derived* from a brane system. The Coulomb branch dimension (2.55) and symmetry are the same as above.

The Higgs branch dimension at infinite coupling has been computed in [16] to be

$$\begin{aligned} \dim_{\mathbb{H}} \mathcal{H}_{\infty}^{6d}(\text{electric theory (2.29)}) &= 29 \cdot n_t + n_h - n_v = n + \dim \text{SO}(2k), & (2.58) \\ n_t &= n, \\ n_h &= \frac{1}{2} \cdot 2k \cdot (2k - 8) \cdot 2n, \\ n_v &= n \cdot \dim(\text{Sp}(k - 4)) + (n - 1) \cdot \dim(\text{SO}(2k)). \end{aligned}$$

Using the formalism of *magnetic quivers*, one is now able to explain the jump in moduli space dimension

$$\dim_{\mathbb{H}} \mathcal{H}_{\infty}^{6d} - \dim_{\mathbb{H}} \mathcal{H}_{\text{fm}}^{6d} = n + 28 = (n - 1) + 29 \quad (2.59)$$

in more detail. As the theory has $(2n - 1)$ tensor multiplets, there are $(2n - 1)$ order parameters that can be tuned and, as such, one expects $(2n - 1)$ distinct phase transitions. The above analysis demonstrates the following:

- (i) There are $(n - 1)$ transitions of the form

$$1 \text{ tensor} + 1 \text{ SO}(8) \text{ vector} \rightarrow 1 \text{ hyper} \quad (2.60)$$

such that the moduli space jumps by one quaternionic unit. This will be called a D_4 transition.

- (ii) There is precisely one small E_8 instanton transition

$$1 \text{ tensor} \rightarrow 29 \text{ hyps} \quad (2.61)$$

and the dimension has to jump by 29.

- (iii) There are $(n - 1)$ discrete gauging transitions in which the Higgs branch does not jump in dimension.

Geometrically, the magnetic quivers also allow to study the transverse slices. As in (3.11), one can take the difference between the magnetic quivers (2.43) and (2.50), describing the phase before and after the final transition. By the results of [41], the Coulomb branch of this *difference quiver* describes the transverse slice. Inspecting the relevant theories reveals

$$\text{magnetic quiver (2.50)} - \text{magnetic quiver (2.43)} = \text{magnetic quiver (2.25)} \quad (2.62)$$

such that the transverse slice is again the closure of the minimal nilpotent orbit of E_8 , as suspected for an E_8 transition.

2.5 Derivation rules

Having discussed the various transitions between the different Higgs branch phases and how to derive their associated magnetic quivers, one can summarise and formalise the rules as follows:

Conjecture 1 (Magnetic quiver). *For a D6-D8-NS5 brane system in the presence of O6 orientifold planes, cf. table 1, in which all D6 branes are suspended between D8 branes, the massless BPS states, deduced from stretching virtual D4 branes, arise from the following configurations:*

- (i) *Stack of m full D6 branes on top of a O6 plane suspended between two D8s in a finite x^6 interval: the vertical motion along the x^7, x^8, x^9 directions gives rise to a magnetic vector multiplet due to D4s stretched between them. Depending on the type of magnetic O6 plane, the magnetic gauge group is*

$$\begin{array}{c}
 m \text{ D6 \& } O6^- \\
 \left\{ \begin{array}{c} \text{---} \\ \text{---} \\ \text{---} \end{array} \right. \\
 \text{D8}
 \end{array}
 \xrightarrow{\text{magnetic quiver}}
 \begin{array}{c}
 \bigcirc \\
 \mathfrak{d}_m
 \end{array}
 \quad (2.63a)$$

$$\begin{array}{c}
 m \text{ D6 \& } \widetilde{O6}^- \\
 \left\{ \begin{array}{c} \text{---} \\ \text{---} \\ \text{---} \end{array} \right. \\
 \text{D8}
 \end{array}
 \xrightarrow{\text{magnetic quiver}}
 \begin{array}{c}
 \bigcirc \\
 \mathfrak{c}_m
 \end{array}
 \quad (2.63b)$$

$$\begin{array}{c}
 m \text{ D6 \& } O6^+ \\
 \left\{ \begin{array}{c} \text{---} \\ \text{---} \\ \text{---} \end{array} \right. \\
 \text{D8}
 \end{array}
 \xrightarrow{\text{magnetic quiver}}
 \begin{array}{c}
 \bigcirc \\
 \mathfrak{b}_m
 \end{array}
 \quad (2.63c)$$

$$\begin{array}{c}
 m \text{ D6 \& } \widetilde{O6}^+ \\
 \left\{ \begin{array}{c} \text{---} \\ \text{---} \\ \text{---} \end{array} \right. \\
 \text{D8}
 \end{array}
 \xrightarrow{\text{magnetic quiver}}
 \begin{array}{c}
 \bigcirc \\
 \mathfrak{c}_m
 \end{array}
 \quad (2.63d)$$

see also table 4.

# infinite gauge couplings	ℍ-dim of moduli space							
	d	$d+1$	$d+2$	$d+3$	$d+4$	\dots	$d+(n-1)$	$d+(n+28)$
0	\mathcal{H}_{fin}							
1		$\mathcal{H}_{1 \times D_4}^{\{1\}}$						
2			$\mathcal{H}_{2 \times D_4}^{\{1^2\}}$					
3			$\mathcal{H}_{2 \times D_4}^{\{2\}}$	$\mathcal{H}_{3 \times D_4}^{\{1^3\}}$				
4				$\mathcal{H}_{3 \times D_4}^{\{2,1\}}$	$\mathcal{H}_{4 \times D_4}^{\{1^4\}}$			
5				$\mathcal{H}_{3 \times D_4}^{\{3\}}$	$\mathcal{H}_{4 \times D_4}^{\{2,1^2\}}$			
6					\vdots			
7					$\mathcal{H}_{4 \times D_4}^{\{4\}}$			
\vdots						\ddots		
$n-1$							$\mathcal{H}_{(n-1) \times D_4}^{\{1^{n-1}\}}$	
n							$\mathcal{H}_{(n-1) \times D_4}^{\{2,1^{n-2}\}}$	$\mathcal{H}_{1 \times E_8}^{\{1^n\}}$
\vdots							\vdots	$\mathcal{H}_{1 \times E_8}^{\{2,1^{n-1}\}}$
$2n-2$							$\mathcal{H}_{(n-1) \times D_4}^{\{n-1\}}$	\vdots
$2n-1$								$\mathcal{H}_{1 \times E_8}^{\{n\}} \equiv \mathcal{H}_\infty$

Table 5. The multitude of Higgs branch phases for n M5s on a $\mathbb{C}^2/\mathbb{D}_{k-2}$ singularity. The subscript $p \times D_4$ indicates p D_4 transitions, while $1 \times E_8$ indicate the single small instanton transitions. The superscript $\{n_i\}$ denotes a partition of p indicating the discrete gauging of a permutation (sub)groups $\prod_i S_{n_i}$. At finite coupling, the Higgs branch dimension is $d = \dim \text{SO}(2k) - \dim \text{SO}(8)$.

- The discrete gauging transitions do not increase the quaternionic dimension, but the number of infinite couplings increases depending on the length of partition. Thus, Higgs branch phases along the vertical direction are related by discrete gauging. In detail, for a partition $\{n_i\}$ of p

$$\mathcal{H}_{p \times D_4}^{\{1^p\}} \xrightarrow[\text{gauging}]{\prod_i S_{n_i}} \mathcal{H}_{p \times D_4}^{\{n_i\}} \quad (2.69)$$

where the discrete gauging of $\prod_i S_{n_i}$ increases the number of infinite couplings by $\sum_{i=1}^l (n_i - 1) = n - l$, with $l = \text{length of the partition}$. The identical statement holds for $\mathcal{H}_{1 \times E_8}^{\{n_i\}}$ with $\{n_i\}$ being a partition of n .

- The small E_8 instanton transition increases the quaternionic dimension by 29; however, the number of infinite couplings increases only by one. This transition relates

Higgs branch phases in the last two columns of table 5, which means

$$\mathcal{H}_{(n-1) \times D_4}^{\{n_i\}} \xrightarrow[\text{transition}]{E_8 \text{ instanton}} \mathcal{H}_{(n-1) \times D_4}^{\{n'_j\}} \quad (2.70)$$

where $\{n_i\}_{i=1,\dots,l}$ is a partition of $(n-1)$ and $\{n'_j\}$ is a partition of n obtained via appending a single 1 to $\{n_i\}$, i.e. $\{n'_j\} = \{n_1, \dots, n_l, 1\}$.

3 Hasse diagram

In section 2 the different Higgs branches of theories corresponding to n M5s on a D-type singularity have been described via magnetic quivers. Besides providing the Higgs branch description, one can moreover attempt to analyse the Higgs branch geometries understood as symplectic singularities [25]. As put forward in [26], the singularity structure can be encoded in a Hasse diagram. In many cases, the Hasse diagram can be derived either from the brane configuration using Kraft-Procesi transitions [39, 40] or from the magnetic quiver description via quiver subtraction [23, 41].

For Lagrangian theories, the Hasse diagram is intimately related to the Higgs mechanism. In more detail, consider an electric theory with gauge group G and matter fields transforming in some (finite dimensional) representation \mathcal{R} , which renders the theory anomaly-free. Suppose there exists a subgroup $H \subset G$ such that the matter representation \mathcal{R} and the adjoint representation Adj^G decompose into irreducible H representations \mathbf{r}_i as follows:

$$\mathcal{R}|_H = \bigoplus_i a_i \mathbf{r}_i, \quad a_i \in \mathbb{N} \cup \{0\} \quad \text{and} \quad \text{Adj}^G|_H = \text{Adj}^H \oplus \bigoplus_i b_i \mathbf{r}_i, \quad b_i \in \mathbb{N} \cup \{0\}, \quad (3.1)$$

where the infinite summation is taken over all irreducible representations $\{\mathbf{r}_i\}_i$ of H . However, only a finite number of the multiplicities a_i, b_i is non-trivial, because \mathcal{R} is finite dimensional. An assignment of vacuum expectation values breaks $G \rightarrow H$ consistently only if the multiplicities a_i, b_i satisfy finitely many constraints:

$$a_i \geq b_i, \quad \forall i. \quad (3.2)$$

The resulting H gauge theory has matter content transforming as $\mathcal{R}' = \bigoplus_i (a_i - b_i) \mathbf{r}_i$, which is assumed to be anomaly-free. More specifically, \mathcal{R}' may contain the trivial representation $i = \text{triv}$, such that the H gauge theory has non-trivially charged matter $\mathcal{R}'' = \bigoplus_{i \neq \text{triv}} (a_i - b_i) \mathbf{r}_i$ alongside with $(a_{\text{triv}} - b_{\text{triv}}) \geq 0$ massless gauge singlets.

Returning to the G gauge theory, its Higgs branch \mathcal{H}_G admits a foliation $\{\mathcal{L}_\kappa\}$ in which a leaf \mathcal{L}_κ corresponds to the set of vacuum expectation values that break $G \rightarrow H_\kappa$. The closure of a leaf \mathcal{L}_κ is a symplectic singularity parameterised by the $(a_{\text{triv}} - b_{\text{triv}})$ massless states that appear as singlets in the Higgsing process. The leaves themselves admit a partial order via inclusion: $\mathcal{L}_\kappa < \mathcal{L}_\lambda$ if and only if $\mathcal{L}_\kappa \subset \overline{\mathcal{L}_\lambda}$. As argued in [26], the partial order of leaves is in one-to-one correspondence with the partial order among the set of subgroups $\{H_\kappa\}$, such that the G gauge theory can be Higgsed to the corresponding H_κ gauge theory, satisfying (3.2). In other words, $\mathcal{L}_\kappa < \mathcal{L}_\lambda$ if and only if $H_\kappa > H_\lambda$, i.e.

$H_\kappa \supset H_\lambda$. To any ordered pair of leaves $(\mathcal{L}_\kappa, \mathcal{L}_\lambda)$, with $\mathcal{L}_\kappa < \mathcal{L}_\lambda$, there exists an associated transverse slice $\mathcal{S}_{\kappa,\lambda}$, meaning that the space transverse to a point in \mathcal{L}_κ inside the closure $\overline{\mathcal{L}_\lambda}$ equals $\mathcal{S}_{\kappa,\lambda}$. As example, the transverse slice to the pair $(\{0\} \equiv \mathcal{L}_{\text{triv}}, \mathcal{H}_G)$ is just \mathcal{H}_G itself. Likewise, the pair $(\mathcal{L}_\kappa, \mathcal{H}_G)$ has a transverse slice given by the Higgs branch of the H_κ gauge theory with matter content \mathcal{R}'' . This is physically intuitive, as the unbroken gauge theory at any point of \mathcal{L}_κ has gauge group H_κ with corresponding matter fields. Moreover, the commutant C_κ of H_κ inside G is a group of dimension b_{triv} . There are a_{triv} many hypermultiplets transforming under C_κ as \mathcal{F} which, in general, is a sum of irreducible C_κ representations. Consequently, the closure $\overline{\mathcal{L}_\kappa}$ is described by the Higgs branch of the C_κ gauge theory with matter content \mathcal{F} .

As summary, the Hasse diagram encodes the decomposition of the Higgs branch into symplectic leaves. The closures of the leaves correspond to massless states appearing as gauge singlets, if a Higgs mechanism description is available. More generally, the leaf closures are described by magnetic quivers, as exemplified below. Moreover, the transverse slices correspond to Higgs branches of gauge theories, accessible via partial Higgsing (if applicable). For a Higgs branch which does not originate from a Lagrangian theory, the decomposition into symplectic leaves still exists and can be summarised in a Hasse diagram, but there is no description via the Higgs mechanism.

Considering the simplest theories relevant for this paper — 6d $\mathcal{N} = (1, 0)$ $\text{Sp}(k - 4)$ gauge theory with $\text{SO}(4k)$ flavour — the Hasse diagram of the Higgs branch of (2.6) at finite and infinite gauge coupling is detailed in [26, table 8], based on the magnetic quiver realisation with unitary gauge groups [17]. Here, a complementary derivation is pursued from (i) the brane configuration with O6 orientifolds and (ii) magnetic quivers with orthosymplectic gauge groups.

3.1 From brane configuration

Recall that the brane configuration (2.24) describes the Higgs branch at infinite coupling of a single $\text{Sp}(k - 4)$ gauge group with $\text{SO}(4k)$ flavour node. To trace out the structure of the Higgs branch as a symplectic singularity, Kraft-Procesi transitions need to be performed. Hence, one needs to find out which minimal transition is possible. An important realisation is that a minimal transition is accomplished by moving a minimal set of D6 suspended between D8 branes to being suspended between NS5 branes, see for instance [39, 40] and also [26, section 2].

e₈ transition. In view of brane configuration (2.24), the only way to achieve any such transition is to confine the NS5 branes to the orientifold. Once the pair of half NS5s is on the O6⁻ the resulting full NS5 brane cannot fractionate, because there are no D6 branes attached from the left or right. Hence, to achieve a splitting of the full NS5, one has to move some D6 branes onto the NS5 brane, and split each D6 brane to end on a half D8 brane on one side and the NS5 on the other. Respecting the S-rule and remembering that one needs 4 full D6 branes on the left and right of the full NS5 for it to fractionate, the

brane configuration becomes:

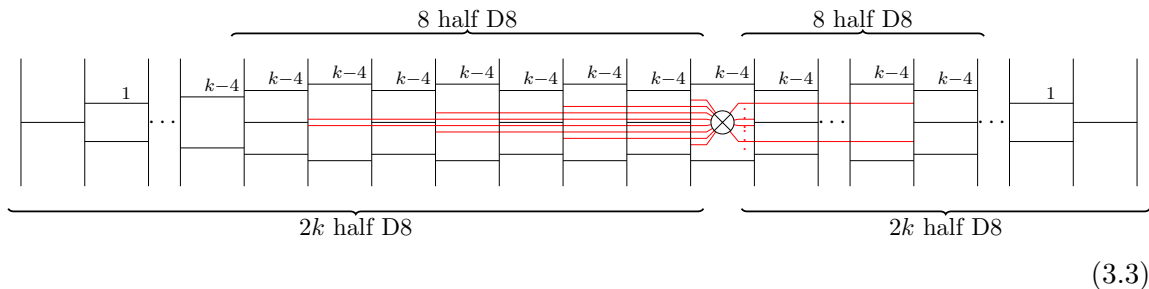

Here, the D6 branes that have been aligned to respect to S-rule are displayed in red; the number of freely moving D6 branes has been adjusted accordingly. Now, the full NS5 brane can fractionate into two half NS5s, which are confined to the O6 plane. To reach an easier to read configuration, one can eliminate the frozen D6 branes between the NS5 and D8 branes via a brane transition of the half NS5 branes through enough half D8 branes. Note that this is analogous to the discussion in section 2.3.2. Taking care of brane annihilation (A.5), the brane configuration becomes

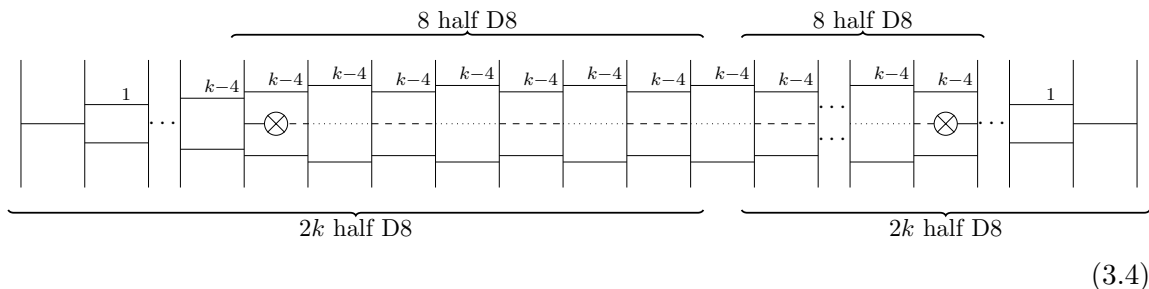

and one recognises that the brane configuration of the remaining freely moving D6 branes yields the finite coupling case of (2.20).

As a consistency check, one counts the loss in magnetic degrees of freedom: there are 28 freely moving (full) D6 segments lost during the transition and the half NS5 branes are confined to the orientifold plane, marking another lost degree of freedom. Therefore, one recovers a loss of 29 quaternionic dimension during the small E_8 instanton transition.

Moreover, one can read off the electric and magnetic theory of this configuration. Unsurprisingly, the magnetic theory is just the one derived in (2.21). The electric theory is seen to be trivial, as there are no D6 branes suspended between the half NS5 branes. In terms of the electric theory (2.6), the triviality of the electric theory in the phase (3.4) is due the locus of the Higgs branch where the $Sp(k - 4)$ gauge group is completely broken to the trivial gauge group.

d_{10} transition. Moving on to the finite coupling Higgs branch, one needs to find all possible Kraft-Procesi transitions. Inspecting brane configuration (3.4), it is straightforward to see the next transition: moving the half NS5 branes outwards through two half

D8 branes each and accounting for brane creation. In detail,

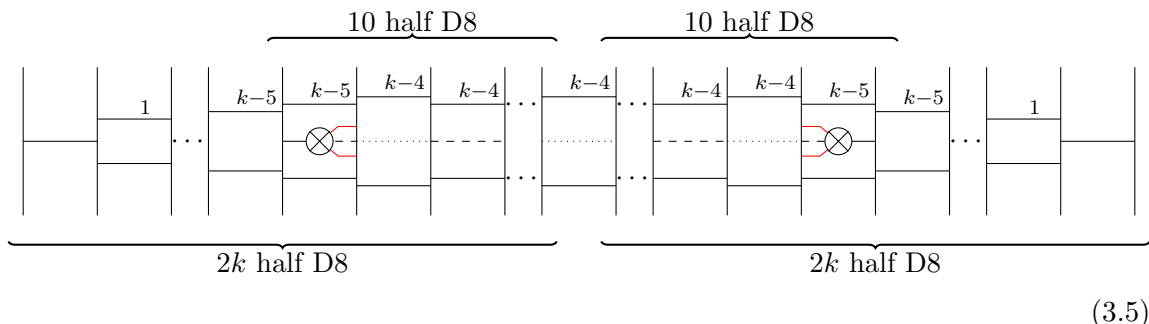

and the created D6 branes (displayed in red) indicate that the next KP-transition proceeds by aligning sufficiently many freely moving D6 such that there is one full D6 brane suspended between the two half NS5s. In the brane configuration, this becomes

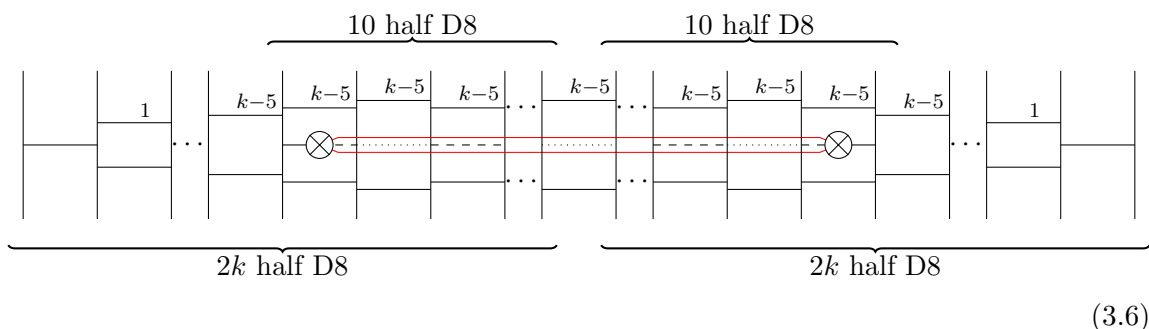

and the numbers of freely moving D6 branes has been adjusted. One computes that the number of lost freely moving D6 branes is 17, and the next step is to figure out the nature of the transition.

Then the remaining magnetic theory is deduced from the freely moving D6 branes, as before. The D6 branes suspended between the half NS5 branes do not contribute, while the NS5 branes still induce flavour nodes. Therefore, the magnetic quiver becomes

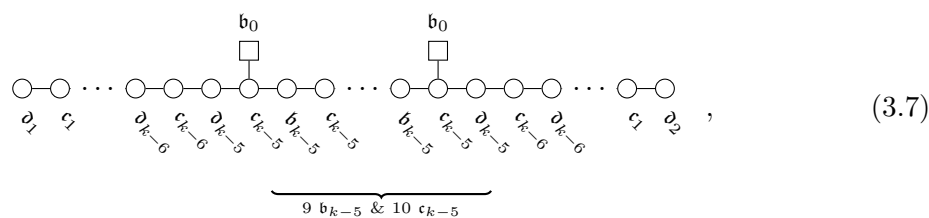

and the Coulomb branch dimension is reduced by 17 in comparison to (2.21).

Next, one reads off the electric theory in this configuration from the red brane subconfiguration, and finds an $Sp(1)$ gauge theory with $SO(20)$ flavour. The Higgs branch thereof is the closure of the minimal nilpotent orbit of $SO(20)$, which has quaternionic dimension 17. A transition of this type is called a d_{10} transition.

More d_{2l} transitions. Lastly, the transition that led to (3.6) can be iterated until all D6 branes are suspended between the NS5 branes.

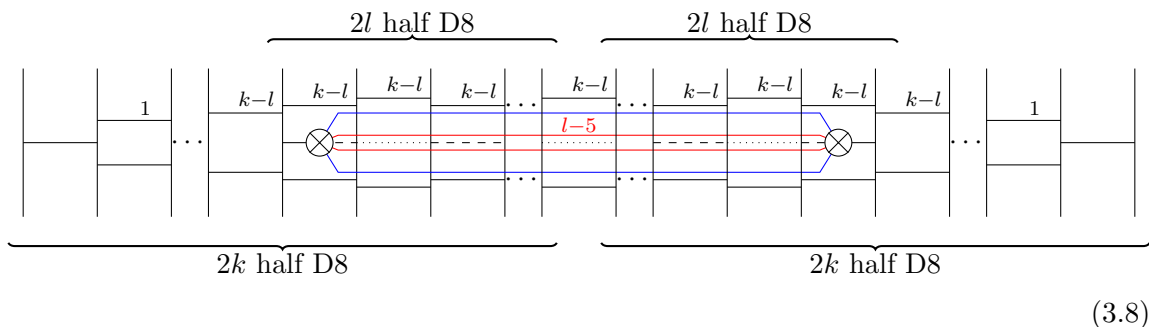

(3.8)

The magnetic theory is determined as before

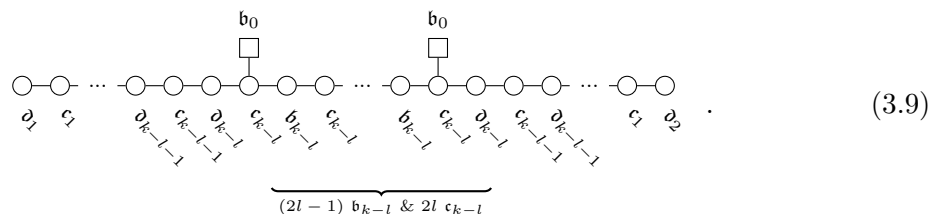

(3.9)

The full electric theory, determined by all red and blue D6 branes in this phase (3.8), is an $\text{Sp}(l-4)$ gauge theory with $\text{SO}(2l)$ flavour group. However, the electric theory corresponding to the KP-transition is given by the blue brane subconfiguration and describes an $\text{Sp}(1)$ gauge theory with $\text{SO}(2l)$ flavour. The Higgs branch of the latter is the closure of the minimal nilpotent orbit of $\text{SO}(2l)$. Therefore, the transition is of type d_l .

The brane configuration for the last step is then straightforwardly deduced by setting $l = k$ in (3.8). For completeness, one verifies the electric and magnetic theory for this configuration. The magnetic theory is empty, as there are no magnetic degrees of freedom left. The electric theory, following from all D6 branes suspended between NS5 branes, is a $\text{Sp}(k-4)$ gauge theory with $\text{SO}(4k)$ flavour. The transition is described by an $\text{Sp}(1)$ gauge group with $\text{SO}(4k)$ flavour such that the Higgs branch thereof is the closure of the minimal nilpotent orbit of $\text{SO}(4k)$. Hence, one recovers a d_{2k} transition.

Summarising the findings, the Hasse diagram is displayed in figure 1. From there, one deduces various geometric relationships such as: for a fixed $\text{Sp}(k-4)$ gauge theory with $\text{SO}(4k)$ flavour, the transverse slice of the Higgs branch at finite gauge coupling inside the Higgs branch at infinite coupling is the minimal nilpotent orbit closure of E_8 . In addition for $4 \leq l < k$, the transverse slice of the Higgs branch of an $\text{Sp}(l-4)$ theory at finite (or infinite) coupling inside the Higgs branch of an $\text{Sp}(k-4)$ theory at finite (or infinite) coupling is the Coulomb branch of the magnetic quiver (3.9).

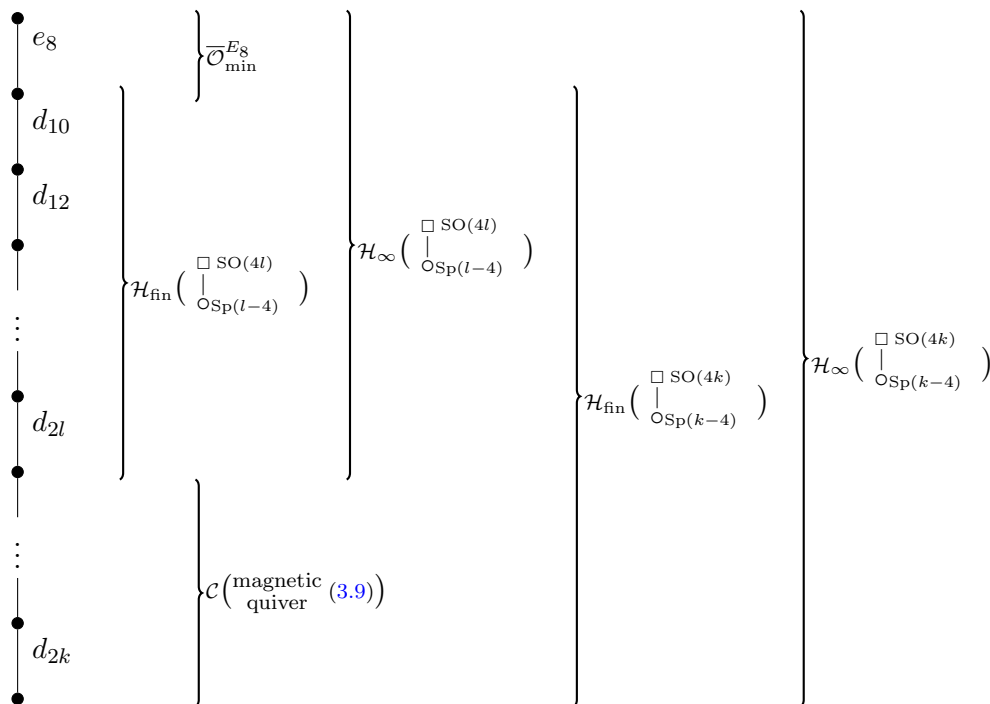

Figure 1. The Hasse diagram for the Higgs branch of (2.6) at infinite gauge coupling. There are two types of minimal transitions: firstly, the e_8 transition, i.e. the transverse slice is the closure of the minimal nilpotent orbit of E_8 . Secondly, various d_{2l} transitions, i.e. the transverse slice is the closure of the minimal nilpotent orbit of $SO(4l)$.

3.2 From quiver subtraction

The analysis can be repeated by means of quiver subtraction [41] that translates the Kraft-Procesi transitions [23, 39, 40] of the brane configurations into an operation on the magnetic quivers. Contrary to [26], the realisation of the KP transitions here requires orthosymplectic quivers. As shown in section 3.1, the simplest case (2.6) only requires an orthosymplectic quiver for the d_{2l} transitions [40, table 7] and for the e_8 transition [23, eq. (2.43)]. The rules for quiver subtraction of minimal transitions in orthosymplectic quivers can be summarised as follows: the two to-be-subtracted quivers are aligned along the common subquiver. One only subtracts gauge nodes of the same algebra type and the arithmetic works like:

$$\mathfrak{b}_n - \mathfrak{b}_l = \mathfrak{b}_{n-l}, \quad \mathfrak{c}_n - \mathfrak{c}_l = \mathfrak{c}_{n-l}, \quad \mathfrak{d}_n - \mathfrak{d}_l = \mathfrak{b}_{n-l}, \quad \text{for } n \geq l. \quad (3.10)$$

The resulting quiver needs to be rebalanced, analogously to [26].

e_8 transition. The small E_8 instanton transition has been discussed in section 2.3 in detail. Inspecting the magnetic quiver (2.25) and knowing the orthosymplectic quiver realisation for the e_8 transition (2.14), one recognises the possibility of subtracting the e_8

4 Conclusions and outlook

In this paper, the formalism of *magnetic quivers* for 6d $\mathcal{N} = (1, 0)$ Higgs branches has been extended to orthogonal and symplectic gauge nodes. Most notably, the entire derivation is based on Type IIA brane configurations and can be summarised as in conjecture 1. The main conceptual point lies in the generalisation of the S-duality rules of O3 planes to the proposed *magnetic orientifolds*, see table 4. In contrast to the physical nature of S-duality for O3 planes, the magnetic orientifolds are purely of conceptual nature. In other words, they are considered as tool that allows to derive the magnetic quivers for D6-D8-NS5 brane configurations in the presences of O6 planes.

In this paper, *all* Higgs branches of the 6d $\mathcal{N} = (1, 0)$ theories coming from a single M5 or multiple M5s on $\mathbb{R} \times \mathbb{C}^2/\mathbb{D}_{k-2}$ have been described with magnetic quivers. The concept of a *magnetic quiver* has been reviewed in section 2.2.

In case of a single M5, the magnetic quivers for the Higgs branch at finite [37] and infinite coupling [23] have been known before. The novel point discussed in section 2.3 is that these magnetic quiver can be derived from a brane configuration and, moreover, this brane construction correctly shows that the Higgs branch phase transition is a small E_8 instanton transition.

In the case of n M5 branes, the magnetic quiver for the Higgs branch at the origin of the tensor branch had only been conjectured in [23]. As discussed in section 2.4, the formalism allows to derive the magnetic quivers for the Higgs branches over every point in the tensor branch. In particular, the nature of the transitions to different singular loci of the tensor branch has been revealed. Generically, there are three type of transitions in order to reach the infinite coupling phase. (i) There are $(n - 1)$ one-dimensional D_4 transitions in which one simultaneously trades one tensor multiplet and one $SO(8)$ vector multiplet for a single hypermultiplet. (ii) There is exactly one small E_8 instanton transition, trading one tensor multiplet for 29 hypermultiplets. (iii) There are $\mathcal{P}(n)$ zero-dimensional discrete gauging transitions. Taking all of these into account leads to a description of the Higgs branch at the origin of the tensor branch.

Returning to the single M5 case, the geometry of the Higgs branches as a symplectic singularity has been studied in section 3. Assuming minimal transitions only, the previously computed Hasse diagram [26] has been rederived using (i) brane configurations with O6 orientifold planes as well as (ii) quiver subtraction for magnetic quivers with orthosymplectic gauge nodes. This results provide a crucial consistency check for the proposal of this paper.

Outlook. An interesting subject is the understanding the Higgs branches of 6d $\mathcal{N} = (1, 0)$ theories from multiple M5 branes near an M9 plane on a D -type ALE space. For the A -type case, this has been answered in [17]. In order to derive magnetic quivers for these systems, there are two necessary ingredients: (i) the rules established in conjecture 1, and (ii) the embedding of $\mathbb{D}_{k-2} \hookrightarrow E_8$. In contrast to the A -type case, the latter is not straightforward and progress [52] has only been achieved recently.

Type IIA system	magnetic quiver
1 NS5 with k D6	$(T_{(1^k)}[\text{SU}(k)] \times T_{(k-1,1)}[\text{SU}(k)] \times T_{(1^k)}[\text{SU}(k)]) // \text{SU}(k)$
1 NS5 on O6^- with k D6	$(T_{(1^{2k})}[\text{SO}(2k)] \times T_{(2k-3,3)}[\text{SO}(2k)] \times T_{(1^{2k})}[\text{SO}(2k)]) // \text{SO}(2k)$
1 NS5 on O6^+ with k D6	$(T_{(1^{2k})}[\text{SO}(2k+1)] \times T_{(2k,2)}[\text{SO}(2k+1)] \times T_{(1^{2k})}[\text{SO}(2k+1)]) // \text{SO}(2k+1)$
1 NS5 on $\widetilde{\text{O6}}^-$ with k D6	$(T_{(1^{2k+1})}[\text{USp}(2k)] \times T_{(2k-1,1^2)}[\text{USp}(2k)] \times T_{(1^{2k+1})}[\text{USp}(2k)]) // \text{USp}(2k)$
1 NS5 on $\widetilde{\text{O6}}^+$ with k D6	$(T_{(1^{2k})}[\text{USp}'(2k)] \times T_{(2k-2,2)}[\text{USp}'(2k)] \times T_{(1^{2k})}[\text{USp}'(2k)]) // \text{USp}'(2k)$

Table 6. The Higgs branch at the origin of the tensor branch can be described by a magnetic quiver obtained from three $T_\rho[G]$ theories [48] glued along the common G flavour node, which is denoted by $///G$.

Further predictions. With conjecture 1 at hand, one can derive predictions for the Higgs branches of a single NS5 brane on either a $\widetilde{\text{O6}}^-$ or $\widetilde{\text{O6}}^+$ plane with k D6 branes. In contrast to configurations on a O6^- plane or a O6^+ plane, discussed above, there exists no gauge theory description and the NS5 brane cannot split along the orientifold. In addition, only the configuration (2.5) with O6^- admits an M-theory dual, while all other three O6 planes only exist as Type IIA systems. Following the prescription outlined in this paper, one finds:

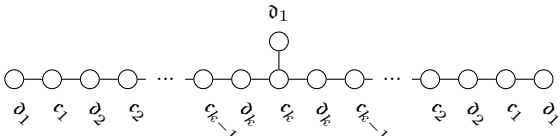
1 NS5 on $\widetilde{\text{O6}}^-$ with k D6:  , (4.4)

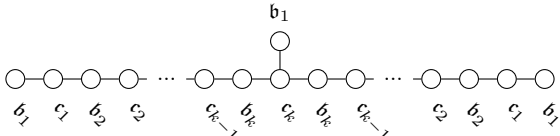
1 NS5 on $\widetilde{\text{O6}}^+$ with k D6:  . (4.5)

By the rules of appendix A.2, one would conclude that the magnetic quiver (4.4) is *good*, with all nodes except the central \mathfrak{d}_1 being *balanced*. Similarly, all nodes in (4.5) are *good*. In view of these predictions and the results of [17], one can summarise the magnetic quiver for a single NS5 brane on k D6 branes with or without an O6 orientifold as in table 6.

Acknowledgments

We are indebted to Antoine Bourget, Julius Grimminger, Rudolph Kalveks, Noppadol Mekareeya, Tom Rudelius, and Zhenghao Zhong for useful discussions. We thank the Simons Center for Geometry and Physics, Stony Brook University for the hospitality and the partial support during the initial stage of this work at the Simons Summer workshop 2018. A.H. and M.S. gratefully acknowledge support from the Simons Center for Geometry and Physics, Stony Brook University during the Simons Summer workshop 2019,

where part of the research for this paper was performed. S.C. was supported by an EP-SRC DTP studentship EP/M507878/1. A.H. is supported by STFC grant ST/P000762/1. M.S. had been supported by Austrian Science Fund (FWF) grant P28590. M.S. thanks the Faculty of Physics of the University of Vienna for travel support via the ‘‘Jungwissentenschaftsförderung’’. The work of M.S. was supported by the National Thousand-Young-Talents Program of China and the China Postdoctoral Science Foundation (grant no. 2019M650616). M.S. thanks the Theoretical Physics Group of Imperial College London for hospitality.

A Background material

A.1 Brane creation and annihilation

Following [36], in a system of Dp - $D(p+2)$ -NS5 branes, Dp brane creation or annihilation happens whenever a NS5 passes through an $D(p+2)$. In the presence of Op planes, which carry non-trivial brane charge, a NS5 brane can pass through an $D(p+2)$ with or without creation of an additional Dp brane. To begin with, recall [6, 28, 54]

- An Op^\pm becomes an Op^\mp when passing through a half NS5; likewise, \widetilde{Op}^\pm turns into \widetilde{Op}^\mp .
- An Op^\pm becomes an \widetilde{Op}^\pm when passing through a half $D(p+2)$, and vice versa.

According to [6, 37], the charges of the Op planes (in unites of the physical Dp branes) are given by

$$\text{charge}(Op^\pm) = \pm 2^{p-5}, \quad \text{charge}(\widetilde{Op}^-) = \frac{1}{2} - 2^{p-5}, \quad \text{charge}(\widetilde{Op}^+) = 2^{p-5}. \quad (\text{A.1})$$

Following the conventions of [46], the different orientifolds are denoted by:

$$O6^- \ \& \ 2n \cdot \frac{1}{2}D6 : \quad \begin{array}{c} \text{n} \\ \text{=====} \end{array}, \quad \widetilde{O6}^- \ \& \ 2n \cdot \frac{1}{2}D6 : \quad \begin{array}{c} \text{n} \\ \text{=====} \\ \text{=====} \end{array}, \quad (\text{A.2})$$

$$O6^+ \ \& \ 2n \cdot \frac{1}{2}D6 : \quad \begin{array}{c} \text{n} \\ \text{-----} \end{array}, \quad \widetilde{O6}^+ \ \& \ 2n \cdot \frac{1}{2}D6 : \quad \begin{array}{c} \text{n} \\ \text{-----} \\ \text{-----} \end{array}, \quad (\text{A.3})$$

i.e. $O6^-$ empty line, $\widetilde{O6}^-$ solid line, $O6^+$ dotted line, $\widetilde{O6}^+$ dashed line.

Next, there are four scenarios for brane creation and annihilation. These follow from preservation of the linking number before and after the transition. The linking numbers l_{NS5} for half NS5 or $l_{D(p+2)}$ for half $D(p+2)$ are defined as [36]

$$l_{\text{NS5}} = \frac{1}{2} (R_{D(p+2)} - L_{D(p+2)}) + (L_{Dp} - R_{Dp}), \quad (\text{A.4a})$$

$$l_{D(p+2)} = \frac{1}{2} (R_{\text{NS5}} - L_{\text{NS5}}) + (L_{Dp} - R_{Dp}), \quad (\text{A.4b})$$

where L_X, R_X denote the total number of branes of type X to the left or right, respectively. Note that the Op planes contribute to L_{Dp} and R_{Dp} according to (A.1); naturally, half NS5 or half $D(p+2)$ branes contribute with charge $\frac{1}{2}$ to the numbers L and R , respectively. It

then follows that

$$\begin{array}{c}
 \begin{array}{c} \tilde{+} \quad \tilde{-} \\ \text{---} \otimes \text{---} \end{array} \quad | \quad \text{---} \\
 \leftrightarrow \\
 \begin{array}{c} \tilde{+} \quad + \quad - \\ \text{---} \otimes \text{---} \end{array} \quad | \quad \text{---}
 \end{array} \tag{A.5a}$$

$$\begin{array}{c}
 \begin{array}{c} + \quad - \quad \tilde{-} \\ \text{---} \otimes \text{---} \end{array} \quad | \quad \text{---} \\
 \leftrightarrow \\
 \begin{array}{c} + \quad \tilde{+} \quad \tilde{-} \\ \text{---} \otimes \text{---} \end{array} \quad | \quad \text{---}
 \end{array} \tag{A.5b}$$

$$\begin{array}{c}
 \begin{array}{c} - \quad + \quad \tilde{+} \\ \text{---} \otimes \text{---} \end{array} \quad | \quad \text{---} \\
 \leftrightarrow \\
 \begin{array}{c} - \quad \tilde{-} \quad \tilde{+} \\ \text{---} \otimes \text{---} \end{array} \quad | \quad \text{---}
 \end{array} \tag{A.5c}$$

$$\begin{array}{c}
 \begin{array}{c} \tilde{-} \quad \tilde{+} \quad + \\ \text{---} \otimes \text{---} \end{array} \quad | \quad \text{---} \\
 \leftrightarrow \\
 \begin{array}{c} \tilde{-} \quad - \quad + \\ \text{---} \otimes \text{---} \end{array} \quad | \quad \text{---}
 \end{array} \tag{A.5d}$$

by requiring that all linking numbers (A.4) remain constant.

A.2 Global symmetry for orthosymplectic quiver

Following [46, section 5.1-5.2], there are conditions upon which orthogonal and symplectic gauge nodes in a 3d $\mathcal{N} = 4$ gauge theory are called *good*, *bad*, or *ugly*. A subset of good gauge nodes are *balanced* gauge nodes, for which monopole operators of spin 1 under the R-charge are expected to lead to symmetry enhancement.

An $SO(k)$ (or $O(k)$) gauge theory coupled to fundamental hypermultiplets with $USp(2n)$ flavour symmetry is called

$$\textit{good} \text{ if } n \geq k - 1, \quad \text{and } \textit{balanced} \text{ if } n = k - 1. \tag{A.6}$$

Analogously, an $USp(2l) = Sp(l)$ gauge theory coupled to fundamental hypermultiplets with $O(2n)$ flavour symmetry is called

$$\textit{good} \text{ if } n \geq 2l + 1, \quad \text{and } \textit{balanced} \text{ if } n = 2l + 1. \tag{A.7}$$

Considering an orthosymplectic quiver, i.e. a linear quiver with alternating orthogonal and symplectic gauge nodes, a chain of p balanced nodes gives rise to the following enhanced Coulomb branch symmetry:

- An $SO(p + 1)$ symmetry, if there are no $SO(2)$ (or $O(2)$) gauge nodes at the ends.
- An $SO(p + 2)$ symmetry, if there is an $SO(2)$ (or $O(2)$) gauge node at one of the two ends.
- An $SO(p + 3)$ symmetry, if there is an $SO(2)$ (or $O(2)$) gauge node at each end.

Open Access. This article is distributed under the terms of the Creative Commons Attribution License ([CC-BY 4.0](https://creativecommons.org/licenses/by/4.0/)), which permits any use, distribution and reproduction in any medium, provided the original author(s) and source are credited.

References

- [1] E. Witten, *Some comments on string dynamics*, in *Future perspectives in string theory. Proceedings, Conference, Strings'95*, Los Angeles, U.S.A., 13–18 March 1995, pp. 501–523 (1995) [[hep-th/9507121](#)] [[INSPIRE](#)].
- [2] A. Strominger, *Open p -branes*, *Phys. Lett. B* **383** (1996) 44 [[hep-th/9512059](#)] [[INSPIRE](#)].
- [3] A. Hanany and A. Zaffaroni, *Branes and six-dimensional supersymmetric theories*, *Nucl. Phys. B* **529** (1998) 180 [[hep-th/9712145](#)] [[INSPIRE](#)].
- [4] I. Brunner and A. Karch, *Branes and six-dimensional fixed points*, *Phys. Lett. B* **409** (1997) 109 [[hep-th/9705022](#)] [[INSPIRE](#)].
- [5] I. Brunner and A. Karch, *Branes at orbifolds versus Hanany Witten in six-dimensions*, *JHEP* **03** (1998) 003 [[hep-th/9712143](#)] [[INSPIRE](#)].
- [6] A. Hanany and A. Zaffaroni, *Issues on orientifolds: On the brane construction of gauge theories with $SO(2N)$ global symmetry*, *JHEP* **07** (1999) 009 [[hep-th/9903242](#)] [[INSPIRE](#)].
- [7] J.J. Heckman, D.R. Morrison and C. Vafa, *On the Classification of 6D SCFTs and Generalized ADE Orbifolds*, *JHEP* **05** (2014) 028 [Erratum *ibid.* **06** (2015) 017] [[arXiv:1312.5746](#)] [[INSPIRE](#)].
- [8] J.J. Heckman, D.R. Morrison, T. Rudelius and C. Vafa, *Atomic Classification of 6D SCFTs*, *Fortsch. Phys.* **63** (2015) 468 [[arXiv:1502.05405](#)] [[INSPIRE](#)].
- [9] M.B. Green, J.H. Schwarz and P.C. West, *Anomaly Free Chiral Theories in Six-Dimensions*, *Nucl. Phys. B* **254** (1985) 327 [[INSPIRE](#)].
- [10] S. Randjbar-Daemi, A. Salam, E. Sezgin and J.A. Strathdee, *An Anomaly Free Model in Six-Dimensions*, *Phys. Lett.* **151B** (1985) 351 [[INSPIRE](#)].
- [11] A. Dabholkar and J. Park, *An Orientifold of type IIB theory on $K3$* , *Nucl. Phys. B* **472** (1996) 207 [[hep-th/9602030](#)] [[INSPIRE](#)].
- [12] A. Sagnotti, *A Note on the Green-Schwarz mechanism in open string theories*, *Phys. Lett. B* **294** (1992) 196 [[hep-th/9210127](#)] [[INSPIRE](#)].
- [13] U.H. Danielsson, G. Ferretti, J. Kalkkinen and P. Stjernberg, *Notes on supersymmetric gauge theories in five-dimensions and six-dimensions*, *Phys. Lett. B* **405** (1997) 265 [[hep-th/9703098](#)] [[INSPIRE](#)].
- [14] M. Bershadsky and C. Vafa, *Global anomalies and geometric engineering of critical theories in six-dimensions*, [hep-th/9703167](#) [[INSPIRE](#)].
- [15] N.J. Hitchin, A. Karlhede, U. Lindström and M. Roček, *HyperKähler Metrics and Supersymmetry*, *Commun. Math. Phys.* **108** (1987) 535 [[INSPIRE](#)].
- [16] N. Mekareeya, K. Ohmori, H. Shimizu and A. Tomasiello, *Small instanton transitions for $M5$ fractions*, *JHEP* **10** (2017) 055 [[arXiv:1707.05785](#)] [[INSPIRE](#)].
- [17] S. Cabrera, A. Hanany and M. Sperling, *Magnetic quivers, Higgs branches and 6d $N = (1, 0)$ theories*, *JHEP* **06** (2019) 071 [Erratum *ibid.* **07** (2019) 137] [[arXiv:1904.12293](#)] [[INSPIRE](#)].
- [18] M. Del Zotto and A. Hanany, *Complete Graphs, Hilbert Series and the Higgs branch of the 4d $\mathcal{N} = 2$ (A_n, A_m) SCFTs*, *Nucl. Phys. B* **894** (2015) 439 [[arXiv:1403.6523](#)] [[INSPIRE](#)].
- [19] S. Cremonesi, G. Ferlito, A. Hanany and N. Mekareeya, *Instanton Operators and the Higgs Branch at Infinite Coupling*, *JHEP* **04** (2017) 042 [[arXiv:1505.06302](#)] [[INSPIRE](#)].

- [20] G. Ferlito, A. Hanany, N. Mekareeya and G. Zafrir, *3d Coulomb branch and 5d Higgs branch at infinite coupling*, *JHEP* **07** (2018) 061 [[arXiv:1712.06604](#)] [[INSPIRE](#)].
- [21] S. Cabrera, A. Hanany and F. Yagi, *Tropical Geometry and Five Dimensional Higgs Branches at Infinite Coupling*, *JHEP* **01** (2019) 068 [[arXiv:1810.01379](#)] [[INSPIRE](#)].
- [22] N. Mekareeya, K. Ohmori, Y. Tachikawa and G. Zafrir, *E_8 instantons on type-A ALE spaces and supersymmetric field theories*, *JHEP* **09** (2017) 144 [[arXiv:1707.04370](#)] [[INSPIRE](#)].
- [23] A. Hanany and N. Mekareeya, *The small E_8 instanton and the Kraft-Procesi transition*, *JHEP* **07** (2018) 098 [[arXiv:1801.01129](#)] [[INSPIRE](#)].
- [24] A. Hanany and G. Zafrir, *Discrete Gauging in Six Dimensions*, *JHEP* **07** (2018) 168 [[arXiv:1804.08857](#)] [[INSPIRE](#)].
- [25] A. Beauville, *Symplectic singularities*, *Invent. Math.* **139** (2000) 541 [[math/9903070](#)].
- [26] A. Bourget et al., *The Higgs mechanism — Hasse diagrams for symplectic singularities*, *JHEP* **01** (2020) 157 [[arXiv:1908.04245](#)] [[INSPIRE](#)].
- [27] M. Del Zotto, J.J. Heckman, A. Tomasiello and C. Vafa, *6d Conformal Matter*, *JHEP* **02** (2015) 054 [[arXiv:1407.6359](#)] [[INSPIRE](#)].
- [28] N.J. Evans, C.V. Johnson and A.D. Shapere, *Orientifolds, branes and duality of 4-D gauge theories*, *Nucl. Phys. B* **505** (1997) 251 [[hep-th/9703210](#)] [[INSPIRE](#)].
- [29] K.A. Intriligator, *RG fixed points in six-dimensions via branes at orbifold singularities*, *Nucl. Phys. B* **496** (1997) 177 [[hep-th/9702038](#)] [[INSPIRE](#)].
- [30] J.D. Blum and K.A. Intriligator, *New phases of string theory and 6-D RG fixed points via branes at orbifold singularities*, *Nucl. Phys. B* **506** (1997) 199 [[hep-th/9705044](#)] [[INSPIRE](#)].
- [31] K.A. Intriligator, *New string theories in six-dimensions via branes at orbifold singularities*, *Adv. Theor. Math. Phys.* **1** (1998) 271 [[hep-th/9708117](#)] [[INSPIRE](#)].
- [32] S. Ferrara, A. Kehagias, H. Partouche and A. Zaffaroni, *Membranes and five-branes with lower supersymmetry and their AdS supergravity duals*, *Phys. Lett. B* **431** (1998) 42 [[hep-th/9803109](#)] [[INSPIRE](#)].
- [33] N. Mekareeya, T. Rudelius and A. Tomasiello, *T-branes, Anomalies and Moduli Spaces in 6D SCFTs*, *JHEP* **10** (2017) 158 [[arXiv:1612.06399](#)] [[INSPIRE](#)].
- [34] O.J. Ganor and A. Hanany, *Small E_8 instantons and tensionless noncritical strings*, *Nucl. Phys. B* **474** (1996) 122 [[hep-th/9602120](#)] [[INSPIRE](#)].
- [35] N. Seiberg and E. Witten, *Comments on string dynamics in six-dimensions*, *Nucl. Phys. B* **471** (1996) 121 [[hep-th/9603003](#)] [[INSPIRE](#)].
- [36] A. Hanany and E. Witten, *Type IIB superstrings, BPS monopoles and three-dimensional gauge dynamics*, *Nucl. Phys. B* **492** (1997) 152 [[hep-th/9611230](#)] [[INSPIRE](#)].
- [37] B. Feng and A. Hanany, *Mirror symmetry by O3 planes*, *JHEP* **11** (2000) 033 [[hep-th/0004092](#)] [[INSPIRE](#)].
- [38] S. Cremonesi, A. Hanany and A. Zaffaroni, *Monopole operators and Hilbert series of Coulomb branches of 3d $\mathcal{N} = 4$ gauge theories*, *JHEP* **01** (2014) 005 [[arXiv:1309.2657](#)] [[INSPIRE](#)].
- [39] S. Cabrera and A. Hanany, *Branes and the Kraft-Procesi Transition*, *JHEP* **11** (2016) 175 [[arXiv:1609.07798](#)] [[INSPIRE](#)].

- [40] S. Cabrera and A. Hanany, *Branes and the Kraft-Procesi transition: classical case*, *JHEP* **04** (2018) 127 [[arXiv:1711.02378](#)] [[INSPIRE](#)].
- [41] S. Cabrera and A. Hanany, *Quiver Subtractions*, *JHEP* **09** (2018) 008 [[arXiv:1803.11205](#)] [[INSPIRE](#)].
- [42] A. Hanany and M. Sperling, *Discrete quotients of 3-dimensional $\mathcal{N} = 4$ Coulomb branches via the cycle index*, *JHEP* **08** (2018) 157 [[arXiv:1807.02784](#)] [[INSPIRE](#)].
- [43] A. Hanany and A. Zajac, *Discrete Gauging in Coulomb branches of Three Dimensional $\mathcal{N} = 4$ Supersymmetric Gauge Theories*, *JHEP* **08** (2018) 158 [[arXiv:1807.03221](#)] [[INSPIRE](#)].
- [44] K.A. Intriligator and N. Seiberg, *Mirror symmetry in three-dimensional gauge theories*, *Phys. Lett.* **B 387** (1996) 513 [[hep-th/9607207](#)] [[INSPIRE](#)].
- [45] P. Goddard, J. Nuyts and D.I. Olive, *Gauge Theories and Magnetic Charge*, *Nucl. Phys.* **B 125** (1977) 1 [[INSPIRE](#)].
- [46] D. Gaiotto and E. Witten, *S-duality of Boundary Conditions In $N = 4$ Super Yang-Mills Theory*, *Adv. Theor. Math. Phys.* **13** (2009) 721 [[arXiv:0807.3720](#)] [[INSPIRE](#)].
- [47] F. Benini, Y. Tachikawa and D. Xie, *Mirrors of 3d Sicilian theories*, *JHEP* **09** (2010) 063 [[arXiv:1007.0992](#)] [[INSPIRE](#)].
- [48] S. Cremonesi, A. Hanany, N. Mekareeya and A. Zaffaroni, *$T^{\sigma}(G)$ theories and their Hilbert series*, *JHEP* **01** (2015) 150 [[arXiv:1410.1548](#)] [[INSPIRE](#)].
- [49] S. Cabrera, A. Hanany and Z. Zhong, *Nilpotent orbits and the Coulomb branch of $T^{\sigma}(G)$ theories: special orthogonal vs orthogonal gauge group factors*, *JHEP* **11** (2017) 079 [[arXiv:1707.06941](#)] [[INSPIRE](#)].
- [50] O. Chacaltana and J. Distler, *Timkertoys for the D_N series*, *JHEP* **02** (2013) 110 [[arXiv:1106.5410](#)] [[INSPIRE](#)].
- [51] Z. Zhong, *Quiver gauge theories in 3d, 5d and 6d*, MSc Thesis, Imperial College, London (2018).
- [52] D.D. Frey and T. Rudelius, *6D SCFTs and the Classification of Homomorphisms $\Gamma_{ADE} \rightarrow E_8$* , [arXiv:1811.04921](#) [[INSPIRE](#)].
- [53] M. Del Zotto and G. Lockhart, *Universal Features of BPS Strings in Six-dimensional SCFTs*, *JHEP* **08** (2018) 173 [[arXiv:1804.09694](#)] [[INSPIRE](#)].
- [54] A. Hanany and B. Kol, *On orientifolds, discrete torsion, branes and M-theory*, *JHEP* **06** (2000) 013 [[hep-th/0003025](#)] [[INSPIRE](#)].