

Magneto-optical technique for detecting the biaxial nematic phaseT. Ostapenko,^{1,*} C. Zhang,² S. N. Sprunt,¹ A. Jákli,² and J. T. Gleeson¹¹*Department of Physics, Kent State University, Kent, Ohio 44242, USA*²*Chemical Physics Interdisciplinary Program and Liquid Crystal Institute, Kent State University, Kent, Ohio 44242, USA*

(Received 15 April 2011; revised manuscript received 26 May 2011; published 5 August 2011)

The existence of the elusive biaxial phase has been the subject of much discussion since it was predicted by Freiser in 1970. More recently, there have been numerous attempts to find a thermotropic liquid crystal that exhibits a biaxial phase and with this, conflicting reports about whether such a phase has been positively identified in bent-core liquid crystals. One reason for the discrepancy is that there is currently no way to rule out surface effects or anchoring transitions, both of which may give a false positive identification of a uniaxial-biaxial nematic transition. We have developed a technique that uses a magnetic field to align the uniaxial director, thus widening its application to any bent-core nematic material.

DOI: [10.1103/PhysRevE.84.021705](https://doi.org/10.1103/PhysRevE.84.021705)

PACS number(s): 64.70.M–, 61.30.Gd

I. INTRODUCTION

The theoretical possibility of a biaxial nematic (N_b) phase [1] has motivated physicists to search for this state of matter using various experimental methods in an attempt to determine which, if any, materials exhibit this phase. Initial experiments to test for an N_b phase were performed on calamitic liquid crystals [2]. However, noncalamitic liquid crystals are promising candidates to exhibit a biaxial nematic phase because of their lower molecular symmetry [3] compared to calamitics. Recently, liquid crystals with bent-core mesogens have also been tested [4,5], as they might hold possibilities for fast-switching optical devices [6,7]. With this, there have been findings of biaxial order in bent-core nematic liquid crystals [8–12]; however, there are recent reports that call this into question [13–15]. Thus, the situation is currently unresolved; one reason for this is the difficulty in unambiguously identifying the biaxial nematic phase, because surface effects and a possible anchoring transition [16] may overshadow the nematic uniaxial-biaxial transition.

The uniaxial nematic phase (N_u) has a single symmetry axis, defined by the optic axis, which is commonly denoted by a unit vector field \mathbf{n} . In contrast, the N_b phase has two different directors, denoted as \mathbf{n} and \mathbf{m} , which correspond to the different unique axes along which the molecule can align. In the case of a bent-core molecule, \mathbf{n} and \mathbf{m} , correspond to the axis across the “wingspan” and the axis perpendicular to the wingspan’s plane, respectively. In the N_u phase, the orientational ordering is in the direction of \mathbf{n} , whereas in the N_b phase, the liquid crystal phase can be aligned in two directions. This corresponds to two axes along which a plane polarized light beam can travel without any alteration to its state of polarization [6]; the optic axes are not coincidental with the directions \mathbf{n} and \mathbf{m} .

One straightforward way to identify the N_u phase is to induce an alignment in \mathbf{n} such that this direction is parallel to the light rays traversing the material. If \mathbf{n} is not strictly parallel to the propagation direction, a nonzero phase difference will result when the material is viewed between crossed polarizers. In the latter case, it is particularly difficult to distinguish the

difference between the N_u and the N_b states, because unless the \mathbf{m} director is also uniform, there is no way to tell whether the observed optical phase difference is caused by a misalignment of \mathbf{n} compared to the propagation direction, or a nonzero biaxiality. Specifically, in order to determine using purely visual techniques whether a substance is biaxial is problematic: First, one must be certain that \mathbf{n} is aligned fully parallel to the light propagation direction, as even a slight deviation could be misidentified as an N_b phase. This is illustrated in Fig. 1.

As the magnitude of field-induced birefringence due to nematic biaxiality was shown to be two orders of magnitude smaller than that measured in the SmA_B phase of other bent-core materials [17], one must also consider the effect of surface-induced biaxiality, which may occur, even in fully uniaxial phases where no stable N_b phase or fluctuations exist. Therefore, in order to rule out any possible surface-induced biaxiality, one must be confident that \mathbf{n} is fully uniform. For materials with a positive dielectric anisotropy and in the limit of infinite external electric field, \mathbf{n} will align parallel to the field. If one optically probes the material using a propagation direction parallel to the field, the existence of a preferred orientational direction in the plane perpendicular to the field would constitute a definitively positive indicator of nonzero biaxial order. Indeed, measuring the magnitude of the optical phase difference for a light ray having a polarization vector in this plane yields an upper bound on birefringence when the direction of propagation is parallel to \mathbf{n} . This technique is developed in Ref. [13].

However, many liquid crystal materials, especially those having a bent-core shape, exhibit negative dielectric anisotropy in the frequency range of interest. It is for this reason we have developed the present technique that uses an external magnetic field to fully align the uniaxial director for any liquid crystal with a positive diamagnetic anisotropy, which is by far the most common case. In order to accurately extrapolate to an infinitely large field, one needs as strong a magnetic field as possible. For this reason, the experiments described in this paper required a nonconventional Bitter magnet.

II. SAMPLE PREPARATION

We tested four materials that exhibit nematic phases, all but one of which are bent-core nematics. The calamitic

*tostapen@kent.edu

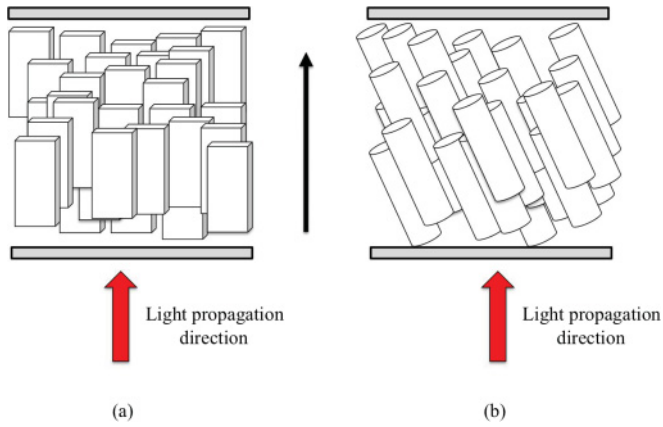

FIG. 1. (Color online) (a) Homeotropically aligned biaxial liquid crystal; (b) tilted uniaxial liquid crystal. When light is propagated parallel to the direction of the applied magnetic field (shown as the black arrow), a slight deviation from complete alignment with the field can cause a misidentification of an N_b phase.

4'-pentyl-4-cyanobiphenyl (5CB) was tested as a control material for our technique, as there is no question to its uniaxial nature. Thus, our analysis with this technique must also yield the same result as previous experiments. We tested 4-chloro-1,3-phenylenebis[4-(4-*n*-decenyloxy) benzoyloxy benzoate], abbreviated to CIPbis10BB [18], 2-methyl-3-[4-(4-octyl-benzoyloxy)-benzylidene]-amino-benzoic acid 4-(4-dodecyl-phenylazo)-phenyl ester (A131) [11], and ODBP-Ph-C7, abbreviated to C7 [9], which was independently and previously reported to exhibit spontaneous biaxial order [8–10].

Our samples of 5CB, CIPbis10BB, and A131 were contained in standard glass sandwich EHC cells (EHC Company, Japan), whereas our sample of C7 was contained in a homemade sandwich cell with planar alignment. We measured the temperature of isotropic-nematic transition, denoted as T_{IN} , at zero magnetic field by cooling the sample and monitoring the amount of light transmitted when the sample is between crossed polarizers. The transition temperature was taken to be the temperature at which the transmittance signal became

significantly nonzero. The phase sequences for our samples are reported as follows: CIPbis10BB: I—(76.1 °C)— N —(65 °C)—Cr [19]; A131: I—(176.5 °C)— N_u —(149.0 °C)— N_b —(118.5 °C)—SmC—(104.3 °C)—SmX—(93.4 °C)—SmY—(82.8 °C)—Cr [11]; C7: I—(222 °C)— N_b —(173 °C)—SmC—(166 °C)—SmX—(148 °C)—Cr [10].

III. EXPERIMENTAL DETAILS

The liquid crystal sample cell is inserted into a temperature-controlled aluminum oven having holes drilled for optical access. The oven was placed inside the 31-T solenoid at the National High Magnetic Field Laboratory. A helium-neon laser ($\lambda = 632.8$ nm) beam is aligned to travel directly up the center of the solenoid bore. The laser beam is linearly polarized at 45° to the axis of a Hinds photoelastic modulator. The beam exiting the oven encounters an analyzer oriented at -45° . The optical setup is illustrated in Fig. 2. Additionally, after the photoelastic modulator, we inserted a Soleil-Babinet compensator that was adjusted to cancel out contributions from residual birefringence in the glass substrates and/or phase differences introduced by the mirror. All adjustments of the compensator were done while the sample was in its fully isotropic phase. The light intensity is measured by a photodiode and analyzed using a lock-in amplifier. This technique has the advantage that it directly measures the phase difference between extraordinary and ordinary rays and contains no contribution caused by Faraday rotation [20].

Our experimental protocol was to sweep the field from 0 T to either 25 or 30 T (sweep rate 1 T/min) at fixed temperatures above and below T_{IN} . After sweeping the field at 1 T/min, we waited at 30 T for ~ 10 min in case any field-induced effects occurred at a slower rate than the sweep rate. Data from increasing field sweeps were compared with decreasing field sweeps to check for hysteresis. Additionally, we heated the sample at 30 T in order to observe if there was any temperature dependence on the phase at high field.

We expect one of two situations to occur. If the material is uniaxial, the effective optical phase difference φ , as a function of field, should approach zero as the field tends towards infinity,

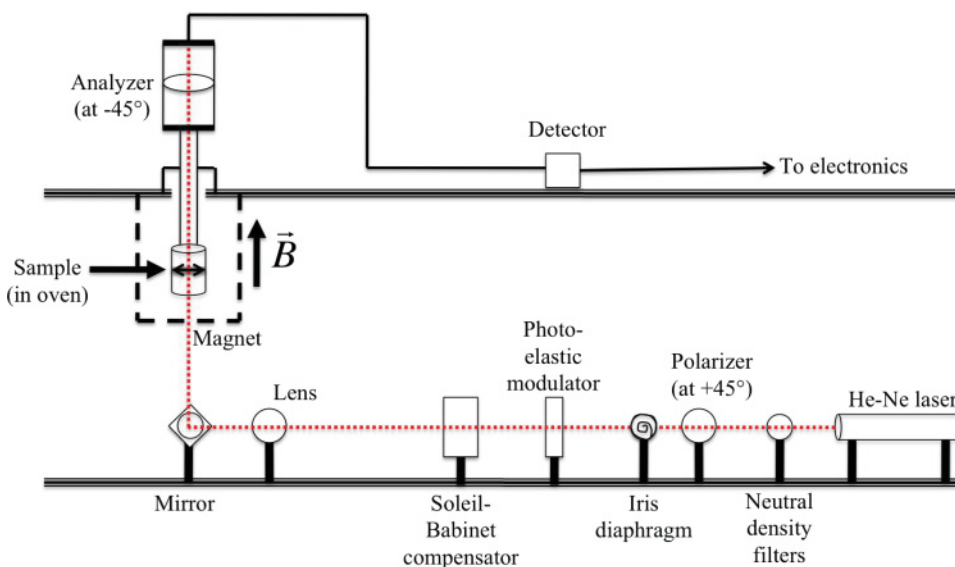

FIG. 2. (Color online) Optical setup for magneto-optical technique. See text for detailed description.

as this field will completely align with \mathbf{n} . This results in an optically isotropic signal, as \mathbf{n} is completely parallel to the propagation direction. However, if the material is biaxial, φ will not reach zero, even at high values of magnetic field and even after \mathbf{n} is parallel to the propagation direction, which is by definition perpendicular to \mathbf{m} [13].

IV. RESULTS AND DISCUSSION

We used the Jones calculus [21] to model the way in which light propagates through an anisotropic medium. In our experimental geometry, we must consider that there may be some Faraday rotation, in addition to induced optical phase difference. Thus, one must introduce a matrix representing an optically rotary element in the Jones calculus, along with the representations for the other optical elements. Doing so and expanding in terms of Bessel functions of the first and second harmonic signals yields a final intensity of [22]

$$I(t) = \frac{1}{2} [1 - J_0(A) \cos(\varphi) \sin(2\alpha) + 2J_1(A) \sin(\varphi) \sin(\alpha) \sin(\omega t) + 2J_2(A) \cos(\varphi) \sin(\alpha) \sin(2\omega t) + \dots], \quad (1)$$

where α is the angle of optical rotation, $\varphi = \varphi_e - \varphi_o$ is the optical phase difference, A is the amplitude of photoelastic modulation (in radians) and $J_n(A)$ are the Bessel functions of the first kind.

From this expression, we see that the optical signal can be expressed as Fourier amplitudes at frequencies 0, ω , 2ω , etc. If we denote such amplitudes as V_ω , $V_{2\omega}$, etc., we can solve for the tangent of the optical phase difference:

$$\tan(\varphi) = \frac{V_{1\omega} J_2(A)}{V_{2\omega} J_1(A)} \quad (2)$$

and the optical rotation factors cancel out.

We plot φ versus B for all materials in order to determine the behavior of the induced phase difference. We can see in Fig. 3 that the phase difference for 5CB at 30 °C extrapolates to zero

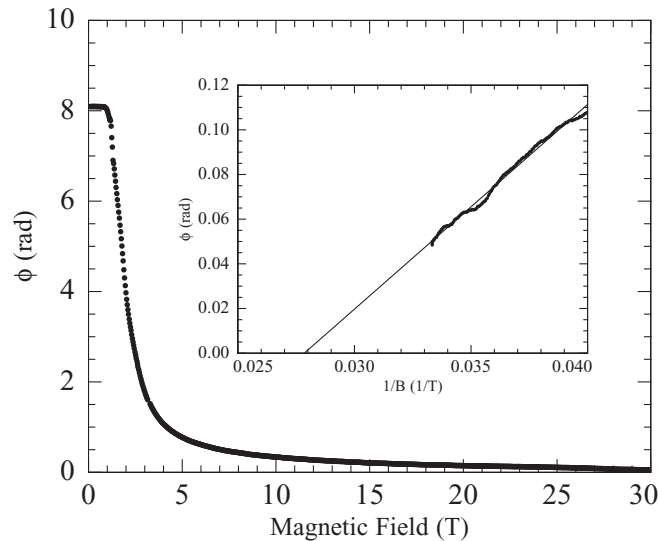

FIG. 3. φ vs B for 5CB at 30 °C. The inset shows φ vs $1/B$, where φ extrapolates to zero at finite field. This is because of finite surface anchoring strength [23].

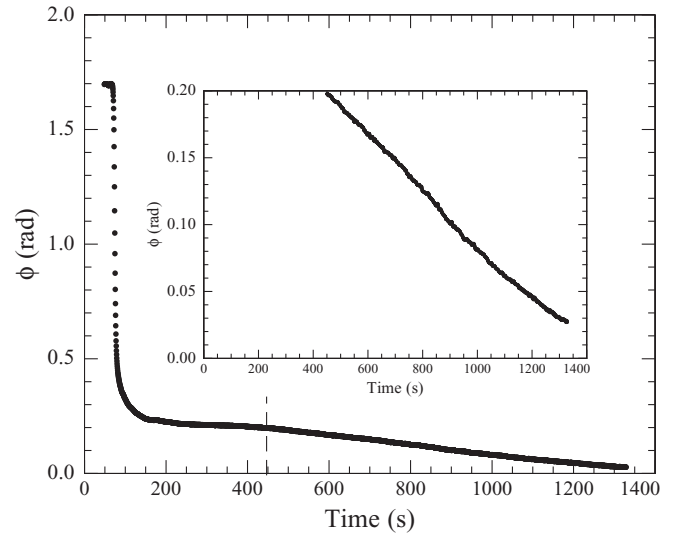

FIG. 4. φ vs B for CIPbis10BB at 73 °C, during the 0–30-T ramp and a 10-min waiting period. The vertical dotted line denotes the point at which the field reached 30 T (450 s) and the wait period began.

at finite field. The splay Freedericksz transition is also readily apparent. For this material and this thickness, the maximum field used, 30 T, is 30 times the threshold Freedericksz field, 1 T. Thus, the maximum diamagnetic torque is 900 times larger than that needed to induce rotation, which provides a dramatic demonstration of the value of using unconventional magnets. This is an indication that the sample’s nematic phase is purely uniaxial, as is expected. This can be more easily seen in the inset of Fig. 3, where the extrapolation to high field is accentuated.

The second material, CIPbis10BB, has a bent-core shape, and is therefore less symmetric than 5CB; this shape lends itself much more naturally to biaxial order. In Fig. 4, we see the splay Freedericksz transition at 4 T, but the optical phase

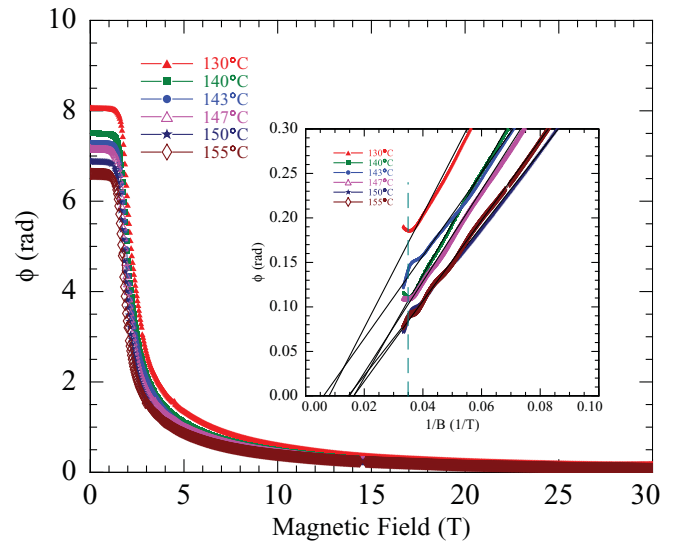

FIG. 5. (Color online) φ vs B for A131, where the inset shows φ vs $1/B$. This material has been reported to be biaxial at temperatures below 149 °C [8].

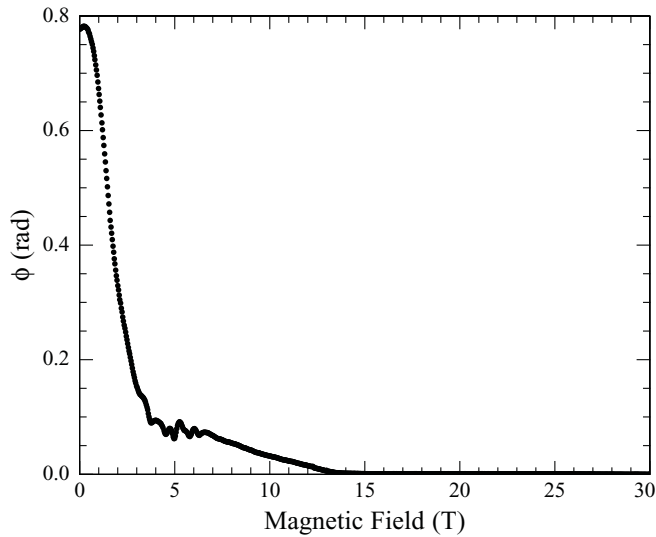

FIG. 6. ϕ vs B for C7. At 13 T, ϕ goes to zero, which is due to an anchoring transition.

at 73 °C does not reach zero at 30 T. However, given that CIPbis10BB is substantially more viscous ($\gamma_1 \sim 2.6$ Pa s [24]) than 5CB, the time scale for the response to the field is long [25]. As a result, we waited at 30 T for ten times that of the orientational diffusion time after the field stopped increasing in order to observe the behavior of the optical phase. Figure 4 shows the optical phase during the field ramp and the wait period, where the waiting period at 30 T begins at 450 s. As expected, the system was slow in responding to the applied field due to its high viscosity. Nonetheless, we see that the optical phase difference approaches zero, but it is necessary to wait for some time after reaching very high field; this indicates uniaxial order. This conclusion was also reached by dynamic light scattering studies on the same material [26].

The third material, A131, also has a bent-core shape. For this material, there have been publications using different techniques that both report [11,12] and do not find [15] biaxial order. We performed field sweeps at a variety of temperatures throughout the entire nematic phase sequence, including throughout any previously reported N_u and N_b phases. These results are presented in Fig. 5, where the splay Freedericksz transition appears at 2 T. Similar to CIPbis10BB, we see the optical phase approaches zero at high field. This is more clearly seen in the inset of Fig. 5, where the optical phase is extrapolated to zero at high field. At fields above 28 T, we

observed increased noise in the phase difference measurement; this was excluded from the extrapolation to infinite field. The noise above 28 T appeared in other materials that we tested, so it is likely due to power fluctuations in the magnet and not a material-dependent property.

The final material we tested, C7, has previously been found to be biaxial [13,16,17], but to our knowledge, this material has not been tested using a technique similar to ours. We performed a field sweep at 200 °C, which is in the region where biaxial order was reported. We note in Fig. 6 that the optical phase attains zero at <15 T, which indicates a lack of biaxial order. The transition seen where the phase difference reaches zero and remains there is most likely explained by an anchoring transition so that the director can fully align with the field. The Freedericksz transition field is <1 T for this sample thickness.

In all the materials, except for C7, the optical phase does not reach zero below 30 T. Extrapolation demonstrates whether the optical phase is approaching a positive value as the field diverges, indicating biaxiality. However, this technique would yield an incorrect conclusion if the trend of the optical phase's dependence on magnetic field were to change at fields above 30 T; however, we are unaware of any mechanism which would cause such a change.

V. CONCLUSIONS

We report an experimental technique based on aligning the uniaxial director along a magnetic field and searching for birefringence perpendicular to that direction. This technique supplies a yes-or-no determination of biaxial order and does not rely heavily on theoretical interpretation to make this determination. Another advantage of this technique is that surface effects and possible anchoring transitions do not overshadow the results. Within our experimental resolution, we found that all four of the materials we tested with this technique show a uniaxial nematic phase, two of which were previously determined to be biaxial.

ACKNOWLEDGMENTS

The authors acknowledge invaluable assistance from S. McGill and W. Aldhizer. This work was supported by NSF (Grants No. DMR-0606160 and No. DMR-0964765). Work performed at the National High Magnetic Field Laboratory is supported by NSF cooperative agreement DMR-0084173, the State of Florida, and the US Department of Energy.

-
- [1] M. J. Freiser, *Phys. Rev. Lett.* **24**, 1041 (1970).
 - [2] L. J. Yu and A. Saupe, *Phys. Rev. Lett.* **45**, 1000 (1980).
 - [3] G. R. Luckhurst, *Nature* **430**, 413 (2004).
 - [4] J. Malthele, L. Liebert, A. M. Levelut, and Y. Galerne, *C. R. Acad. Sci., Ser. II: Mec., Phys., Chim., Sci. Terre Univers* **303**, 1073 (1986).
 - [5] S. Chandrasekhar *et al.*, *Mol. Cryst. Liq. Cryst. Sci. Technol., Sect. A* **288**, 7 (1996); *Curr. Sci.* **75**, 1042 (1998).
 - [6] G. R. Luckhurst, *Thin Solid Films* **393**, 40 (2001).
 - [7] R. Berardi, L. Muccioli, and C. Zannoni, *J. Chem. Phys.* **128**, 024905 (2008).
 - [8] B. R. Acharya, A. Primak, T. J. Dingemans, E. T. Samulski, and S. Kumar, *Pramana* **61**, 231 (2003).
 - [9] L. A. Madsen, T. J. Dingemans, M. Nakata, and E. T. Samulski, *Phys. Rev. Lett.* **92**, 145505 (2004).
 - [10] B. R. Acharya, A. Primak, and S. Kumar, *Phys. Rev. Lett.* **92**, 145506 (2004).
 - [11] V. Prasad, S.-W. Kang, K. A. Suresh, L. Joshi, Q. Wang, and S. Kumar, *J. Am. Chem. Soc.* **127**, 17224 (2005).
 - [12] H. G. Yoon, S.-W. Kang, R. Y. Dong, A. Marini, K. A. Suresh, M. Srinivasarao, and S. Kumar, *Phys. Rev. E* **81**, 51706 (2010).

- [13] K. Van Le, M. Mathews, M. Chambers, J. Harden, Q. Li, H. Takezoe, and A. Jákli, *Phys. Rev. E* **79**, 030701(R) (2009).
- [14] O. Francescangeli and E. T. Samulski, *Soft Matter* **6**, 2413 (2010).
- [15] B. Senyuk, H. Wonderly, M. Mathews, Q. Li, S. V. Shiyankovskii, and O. D. Lavrentovich, *Phys. Rev. E* **82**, 041711 (2010).
- [16] J. S. Patel and H. Yokoyama, *Nature (London)* **362**, 525 (1993).
- [17] K. Fodor-Csorba *et al.*, *ChemPhysChem* **7**, 2184 (2006).
- [18] K. Fodor-Csorba *et al.*, *Macromol. Chem. Phys.* **203**, 1556 (2002).
- [19] S. H. Hong, J. C. Williams, R. J. Twieg, A. Jákli, J. Gleeson, S. Sprunt, and B. Ellman, *Phys. Rev. E* **82**, 041710 (2010).
- [20] J. C. Kemp, *J. Opt. Soc. Am.* **59**, 950 (1969).
- [21] R. C. Jones, *J. Opt. Soc. Am.* **31**, 488 (1941); H. Hurwitz and R. C. Jones, *ibid.* **31**, 493 (1941); R. C. Jones, *ibid.* **31**, 500 (1941); R. C. Jones and R. Clark, *ibid.* **32**, 486 (1942).
- [22] B. Wang, "Polarimetry-Optical Rotation." Photoelastic Modulator Hinds Application Note Rev. Jan. 18, 2010.
- [23] H. Yokoyama and H. A. van Sprang, *J. Appl. Phys.* **57**, 4520 (1985).
- [24] D. B. Wiant, J. T. Gleeson, N. Éber, K. Fodor-Csorba, A. Jákli, and T. Tóth-Katona, *Phys. Rev. E* **72**, 041712 (2005).
- [25] E. Dorjgotov, K. Fodor-Csorba, J. T. Gleeson, S. Sprunt, and A. Jákli, *Liq. Cryst.* **35**, 149 (2008).
- [26] S. Stojadinovic, A. Adorjan, S. Sprunt, H. Sawade, and A. Jákli, *Phys. Rev. E* **66**, 060701(R) (2002).