

 Open access • Journal Article • DOI:10.1016/J.CIRP.2016.04.048

Management of product design complexity due to epistemic uncertainty via energy flow modelling based on CPM — [Source link](#)

[Roozbeh Babaeizadeh Malmiry](#), [Jérôme Pailhes](#), [Ahmed Jawad Qureshi](#), [Jean-François Antoine](#) ...+1 more authors

Institutions: [Arts et Métiers ParisTech](#), [University of Alberta](#)

Published on: 01 Jan 2016 - [Cirp Annals-manufacturing Technology](#) (Elsevier)

Topics: [Product design](#), [Uncertainty analysis](#), [Design process](#), [Function \(engineering\)](#) and [Uncertainty quantification](#)

Related papers:

- [Managing Complexity and Uncertainty by a Modelling Approach for Decision Making in Integrated Product/Process Design](#)
- [Management of product characteristics uncertainty based on formal logic and characteristics properties model](#)
- [A framework for enhanced decision-making in aircraft conceptual design optimisation under uncertainty](#)
- [Our Specific Approach on Mastering Uncertainty](#)
- [Modeling Design Concepts under Risk and Uncertainty using Parameterized Efficient Sets](#)

Share this paper:    

View more about this paper here: <https://typeset.io/papers/management-of-product-design-complexity-due-to-epistemic-164p0fyvce>



HAL
open science

Management of product design complexity due to epistemic uncertainty via energy flow modelling based on CPM

Roozbeh Babaeizadeh Malmiry, Jérôme Pailhès, Ahmed Jawad Qureshi,
Jean-François Antoine, Jean-Yves Dantan

► To cite this version:

Roozbeh Babaeizadeh Malmiry, Jérôme Pailhès, Ahmed Jawad Qureshi, Jean-François Antoine, Jean-Yves Dantan. Management of product design complexity due to epistemic uncertainty via energy flow modelling based on CPM. *CIRP Annals - Manufacturing Technology*, Elsevier, 2016, 65 (1), pp.169-172. 10.1016/j.cirp.2016.04.048 . hal-02310881

HAL Id: hal-02310881

<https://hal.archives-ouvertes.fr/hal-02310881>

Submitted on 10 Oct 2019

HAL is a multi-disciplinary open access archive for the deposit and dissemination of scientific research documents, whether they are published or not. The documents may come from teaching and research institutions in France or abroad, or from public or private research centers.

L'archive ouverte pluridisciplinaire **HAL**, est destinée au dépôt et à la diffusion de documents scientifiques de niveau recherche, publiés ou non, émanant des établissements d'enseignement et de recherche français ou étrangers, des laboratoires publics ou privés.

Management of product design complexity due to epistemic uncertainty via energy flow modelling based on CPM

Roozbeh Babaeizadeh Malmiry^{a,*}, Jérôme Pailhès^b, Ahmed Jawad Qureshi^c, Jean-François Antoine^a, Jean-Yves Dantan (2)^a

^a LCFC, Arts et Métiers–ParisTech–Metz, HESAM, ENIM, 4 rue Augustin Fresnel, 57078 Metz Cedex 3, France ^b

^b I2M-IMC-UMR 5295- Arts et Métiers, Esplanade des Arts et Métiers, F-33400 Talence, France

^c 10-361 University of Alberta, Donadeo Innovation Centre for Engineering, 9211 116 Street NW, Edmonton, AB T6G 1H9, Canada

Submitted by Jean-Yves Dantan

Integrated product design and development in today's highly competitive and economically challenging world is a complex process depending upon client requirements. One of the main factors contributing to the complexity of process is uncertainty due to lack of system knowledge, known as epistemic uncertainty. This paper proposes a systematic approach to reduce epistemic uncertainty in design process in early stages of design. The approach is based on "CTOC" and "CPM" to decompose the system behaviour and determine the relationships between function and structure of a system. An application of the approach is demonstrated through an industrial case study.

Uncertainty, Design Method, Conceptual Design

Uncertainty can be in different forms. In a classical taxonomy, it is divided into aleatory and epistemic. Aleatory uncertainty is the

1. Introduction

With increasing customer expectations, technology advancement and transdisciplinarity, complexity in designing a robust product has become one of the main challenges for designers. In order to design products with high standards, designers need to manage various issues which lead to "complexity". Despite the effort of various design researchers in achieving an approach or methodology to deal with design complexity, there are still gaps in this area. This paper fills the gap in managing complexity by bridging functional modelling and structural modelling in product design process.

The concept of complexity can be seen from different point of views. In this paper, among the various existing point of views on complexity [1], three main visions considered are Weber's, ElMaraghy's, and Suh's. Weber's view [2] focuses on qualitative and quantitative product and product development complexity, its measurement and formalisation. Weber introduces five dimensions for complexity: Numerical, Relational/Structural, Variational, Disciplinary, and Organizational complexity. The first three dimensions, which are related to product/system development [2], are taken into account in this paper.

Elmaraghy *et al.* [1], [3] consider three types of product, process and operational complexities for manufacturing systems [3]. As a more developed classification presented in [1], product and process complexity is discussed in addition to market and social factors. Based on Elmeraghy's categorization, the aim of this paper is to reduce product complexity which is related to the design and special specification in each component of the product. Furthermore, product structure and customer requirement as the sources of product complexity is addressed in this vision.

The third interesting vision is from Suh [4], [5] who defines complexity as a measure of uncertainty. The uncertainty can be in understanding the behaviour of the system, in identifying and achieving the Functional Requirements (FR), or time-related.

To sum up, according to the position of this paper, the main sources of complexity are: uncertainty in identifying required function, structure and behaviour of the system, uncertainty in identifying the effective parameters and uncertainty in the relationships among the design parameters. Thus, the focus of this paper is complexity in product design process which is due to *uncertainty* in understanding and modelling the system.

inherent randomness of a phenomenon. Epistemic uncertainty, which is the interest of this paper, is due to the lack of knowledge of the system [6], [7]. Thunnissen [8] added two more categories to this classification: ambiguity and interaction, for study of complex multidisciplinary systems. Ambiguity uncertainty is regarding the miscommunication of different disciplines. Interaction uncertainty is ascending from unanticipated interaction of events/elements in different levels/phases of design. Explicitly in modelling and simulation, Walter *et al.* [9] categorized uncertainty into "uncertainty in data", "uncertainty in model and simulation", "phenomenological uncertainty" and "uncertainty in human behaviour".

In modelling process, to design and analyse a system, it is important to manage these types of uncertainties in different phases of design. This management leads to reduce unnecessary complexities in design process. With this in mind, this paper proposes a systematic approach for modelling a system based on the required function(s). The hierarchical decomposition of the system using the proposed approach gives the designer specific knowledge about the system. So, this knowledge can be used to assess and manage epistemic uncertainties ([8], [9]) in product design process.

The proposed approach is an energy flow modelling approach [10] based on CPM (Characteristics-Properties Modelling) [11] as a framework. Energy flow approach models the behaviour of a system in terms of transmission or conversion of energy. The flow creates a link between functional descriptions of a system with its structural descriptions. CPM (Characteristics-Properties Modelling) [11] is used as a framework to create the model of product. CPM is a modelling approach based on the distinction between "characteristics" (C_i) and "properties" (P_j) of a product. P_j is related to the function whereas C_i is associated to the structure of the product. By modelling the system behaviour using energy flow, the relationships (R_{ij}) between C_i and P_j are established. The result is a pathway for the designer to model and understand the links in the system and therefore manage epistemic uncertainty in product design process.

2. Characteristics-Properties Modelling (CPM)

CPM is the product modelling side of an approach called CPM/PDD which is first proposed by Weber [11], [12]. PDD (Property-Driven Development) is the process side of the approach for developing and designing products. As mentioned earlier, CPM/PDD is based on distinction between C_i and P_j . C_i are

those system parameters that can be controlled directly by the designer, such as shape, dimensions, materials, etc. P_j are system parameters that cannot be controlled directly by the designer but they can be changed by modifications of C_i . Parameters that are not in these two categories but have impacts on the output of the system called External Conditions (EC). EC_k are environmental effects and are not under the control of the designer but it should be integrated in product modelling.

PDD in Weber's approach is used to create the model based on two main relations; Analysis and Synthesis. So, based on given C_i of a product, P_j are determined (Analysis) and based on required properties (RP_j), the product characteristics are established (Synthesis). The analysis-synthesis approach of PDD in conjunction with the product's model in CPM results into a solution. In multidisciplinary complex systems, identifying C_i and their relationships with P_j is not always clear enough for the designer. So, often designer has to deal with several parameters and uncertain links among them.

This paper proposes an approach using synthesis-analysis concept but in more systematic top-down approach. In this approach, energy flow modelling is used for creation of the model and identifying the relations between system's elements.

3. Energy approach – CPM

Among the various functional modelling approaches in literature [13], [14], energy flow modelling is used in this paper. The proposed approach has a function-structure zigzag approach, similar to axiomatic design [15], to create the model of product in the framework of CPM. A general representation of the approach for system model creation is illustrated in figure 1. The approach is composed of a multi-level modeling approach with 2 concurrent, interlinked modeling views. After creation of model in synthesis phase, the model is used to analyze the impact of product characteristics on system's function.

3.1. Level 1

The first column of figure 1 shows the first level of the approach. The approach begins with studying the system (required or existed) as a black box (function-level 1). So, the required function of the system based on needs is defined. As energy vision, other than the quantitative required function of the system (RP_j), the inlet and outlet of the system as types of energy are identified (Level 1-Function). In structure aspect (Level 1structure), a system can be chosen or defined to satisfy the required function. The main properties (P_j) are defined based on required properties (RP_j).

The parameters that are determined in this level (functional and structural aspects) create the model of system based on CPM as shown in the last row of figure 1. The relation (R_{ij}) between these elements should be identified as well. By considering other related parameters (EC_k) the relations create the first part of system model in CPM as shown in CPM-Level 1.

3.2. Level n:

The subsequent levels of proposed approach are based on interoperability of energy model of Pailhès et al. [10] and CPM which is shown in the second column of figure 1. This model is used in both aspects of functional and structural modelling. It studies the system function based on energy transmission or conversion. According to this model, subsystems can be a Converter (To convert one type of energy to another), Transmitter (To transmit the received energy), Operator (To fulfil the system's required action) or Control (To assure the functioning of other elements). So, this model is also called "CTOC". In addition to these elements,

Reference is the system boundary with external environment such as the ground or the user. A representation of this model is illustrated in an arbitrary level n. It is used in both aspects of function and structure.

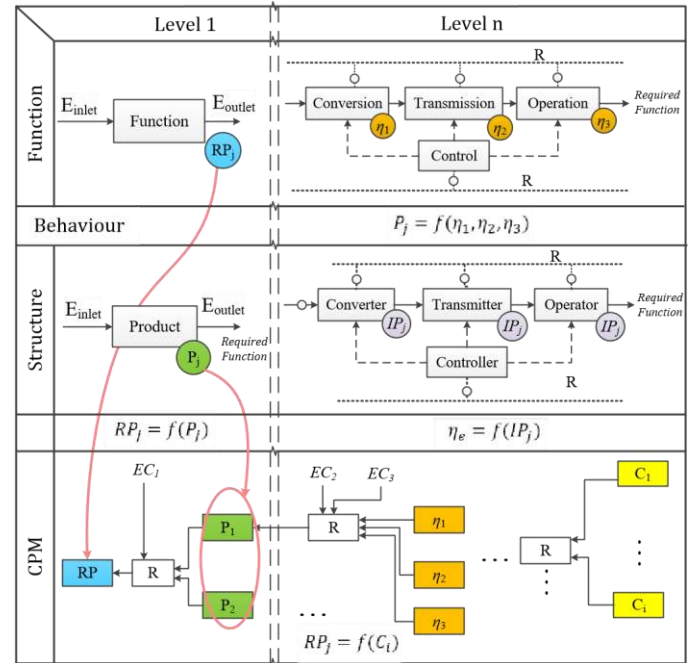

Figure 1. The proposed modelling approach using energy flow and CPM.

In functional aspect, at each level of decomposition of system's function based on CTOC, the important parameters (C_i , P_j) of each element are identified. As figure 1 illustrates, an identified parameter is efficiency (η) since it evaluates the output of subsystem compared to its input. So, efficiency of each sub-system is used as a P_j in this level.

After the functional study of sub-systems, in structural aspect, required choices should be made by the designer. These choices are physical entities (sub-systems, components, etc.) to satisfy the required function. The structure aspect of CTOC is developed in subsequent levels (e.g. level n). Typical types of parameters in this level are losses that cause reduction in efficiency. These parameters along with other parameters (Except those that are C_i) are shown as intermediary properties (IP_j) in this figure. In behaviour aspect, the relations of elements' efficiencies and related IP_j are determined.

In the same way as previous level, the elements, EC_k and their relations establish the next part of system's model in CPM. If an element in this level needs to be studied further, using CTOC, subsystems are decomposed to satisfy the required function.

After desired level of decomposition is reached, the final model of energy approach represents the structural model of the system. This model is based on the structural choices made by the designer during the function and behaviour analyses in previous levels. Other decisions such as the need for extra components or changes in the sequence of components are made as well.

To model the system at this level, a structural modelling language should be used to illustrate the required components and the link between them. In this paper, "Block Diagram" which is one of the diagrams in System Modelling Language (SysML) [16] is used. However, the focus is still on energy flow.

3.3. Creation of the model

In each step of energy flow modelling, after the identification of important parameters, they are used to establish the product

model in CPM. As shown in figure 1, the model is begun with RP_j and based on that P_j is identified in structural aspect. This process is repeated for the parameters in all levels of decomposition. Finally the level of characteristics (C_i), which is mostly based on the final structure model, is established. In each step, the relations (R_{ij}) between the parameters, which include EC_k , should be found. These relations are based on system's behaviour. After the creation of the model the combination of these relations will result in equation 1.

$$P_j = f(C_i, EC_k) \quad (1)$$

If creation of the model and identifying the function in equation 1 is considered as phase 1, the second phase is to use this model to analyse the behaviour of system. So, the impact of C_i s or/and EC_k on system's output can be analysed.

4. Managing complexity by energy flow modelling

In this section, it is discussed how the proposed approach takes three mentioned types of epistemic uncertainty into account which can be used to manage complexity in design process.

4.1. Uncertainty in identifying required function, structure and behaviour of the system

The proposed approach begins with identifying required properties (RP_j). According to the RP_j , the required function of the system is defined or identified. The energy flow models the behaviour of the system using CTOC. Moreover, in each level of decomposition in the proposed approach, the function of system or subsystem is analysed. The energy flow in each level of decomposition (function and structure aspects) keeps the coherence between models and the system's function can be decomposed down to structure. So, it creates a link between system is defined or identified. The energy flow models the

4.2. Uncertainty in identifying the effective parameters

In each level of the approach, thanks to energy flow, important parameters are identified. The importance of these parameters is based on designer's objective and function of system or subsystems. These elements are established as required properties, properties, or intermediary properties in CPM. Another group of parameters in CPM is external condition (EC_k). If the designer believes there are some environmental impacts on system's function, they can be added and the impact in created model can be evaluated by equation 1. In addition, this approach gives a pathway to the designer to look for these parameters. In every transition from function to structure, or from one level to another, the relationships (R_{ij}) should be determined. Normally, this is done by using energy equations. If other parameters appeared in the equation and cannot be classified as C_i or P_j , it should be considered as EC_k .

4.3. Uncertainty in the relationships among the design parameters

The proposed approach creates a pathway for the designer for functional decomposition. In each level of decomposition, in both function and structure aspects, important parameters as well as the relation between them are identified. The proposed approach decomposes the design problem, so it is easier to manage. Systematic study of system step by step makes the identifications of relations easier.

Thanks to these relationships, in a local sensitivity analysis (LSA) [17] the impact of each characteristic on properties can be

analysed. In a global sensitivity analysis (GSA) [18], the impact of a combination of two or more characteristics can be analysed. Furthermore, the designer can use GSA to sort the characteristics based on their impact on the output.

5. Case Study

For better presentation of the proposed approach, a typical hair dryer is used as a case study. The proposed approach is illustrated in figure 2.

Level 1 start with functional analysis of required system. In this case, the main function is defined as "dry hair". In a quantitative approach calorific power (P) is considered as the main parameter. In structure aspect, two parameters of Q_v (air flow) and ΔT (Temperature rise) are taken into account. The relation between them (R1) is determined as the behavioural aspect of the study. So these elements in addition to their relation establish the first part of the model in CPM.

In level 2, the system function is decomposed using the energy model. The function of "Dry air" is decomposed into "Heat air", "Generate air flow", "Guide air flow" and "Control". The important parameters are the efficiency of each element (η_e, η_v, η_p). In structure aspect, required components are identified ("Heating element" and "Nozzle") or defined ("Air flow generator") and the relations (R2, R3) are added to the model in CPM.

To satisfy the function of "Generate air flow", energy model is used again. According to this model, two functions of "Generate mechanical energy" (C) and "Move air" (O) are needed as well as a sub-system to transmit the energy (T).

This approach is continued until all the elements and their relationships are determined. So, by functional analysis of energy model and decisions that are made during the decomposition process, the necessary elements of the system are identified. So, the designer would have knowledge about the minimum requirements of the system to satisfy the required function. Depending on the designer's point of view, other components are added. The structural model of the system using block diagram is shown in level 3-structure in figure 2.

Based on the objective, modelling conditions and designer's decisions, the model of system is completed in CPM. The result is the system performance as a function of characteristics and external conditions as shown in equation 1. This equation in this case is as shown in equation 2.

$$P = f(\omega, C, \lambda, \lambda_L, L_B, L, e, C_p, \rho, U, I, \Delta p) \quad (2)$$

6. Conclusion

One of the challenges in design process that designers have to deal with is epistemic uncertainty which leads to complexity. The proposed approach helps the designer to deal with epistemic uncertainty in identifying required function, structure and behaviour of the system, in identifying the effective parameters and in the relationships among the design parameters.

The energy approach provides knowledge about the minimum requirements of a system to the designer. In addition, thanks to systematic top-down nature of the approach, identifying effective parameters including characteristics and external impacts as well as their relationships becomes easier. Therefore, the knowledge generated by the approach reduces the epistemic uncertainty in product design process. The created model can be used to analyse the behaviour of the system in different conditions and analysis of the change impact of characteristics. Thus, the complexities caused by the epistemic uncertainty can be managed.

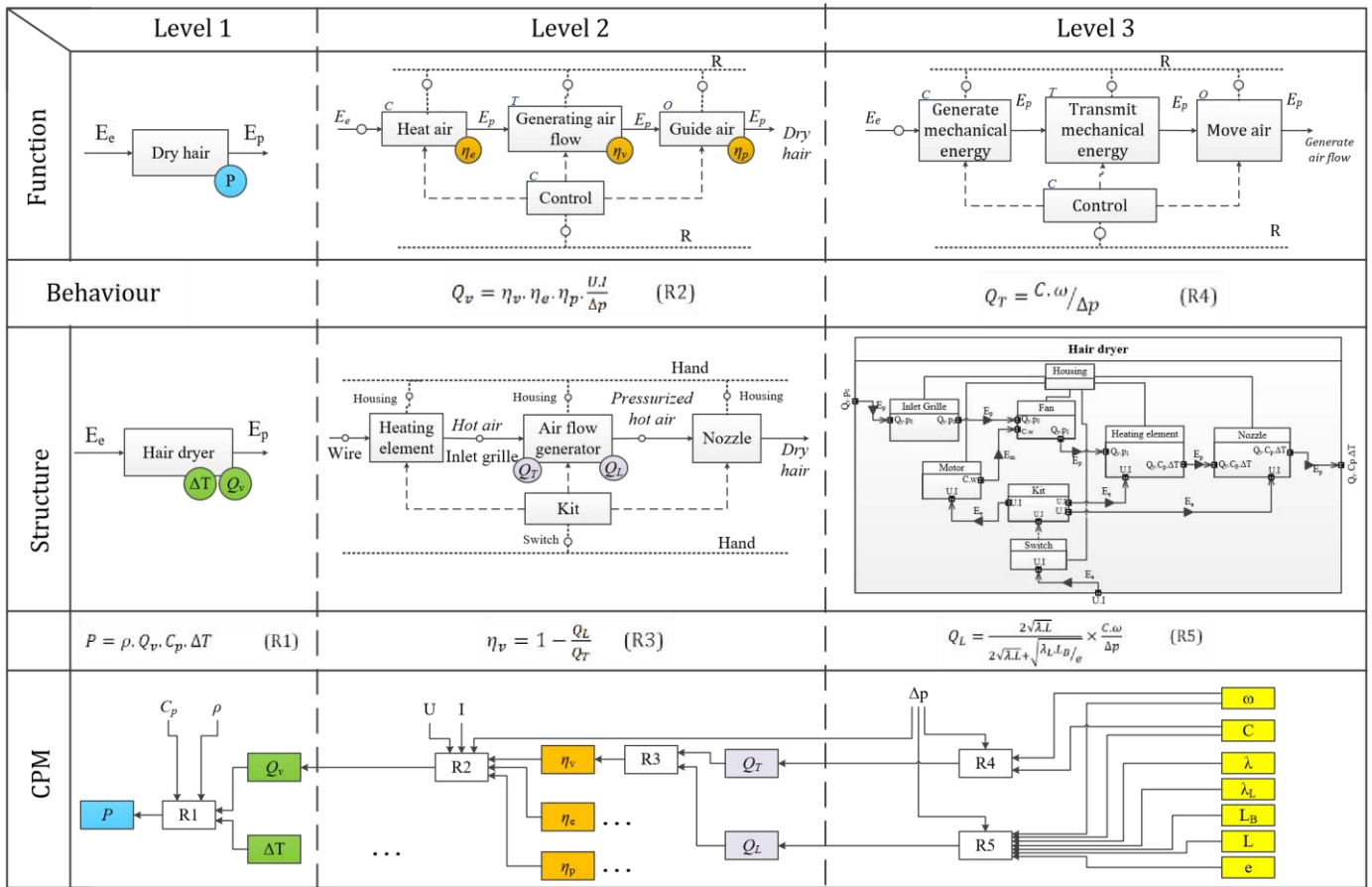

Figure 2. An illustration of the proposed approach on a hair dryer.

The energy flow modelling approach is most applicable for designing systems with at least one energy flow. So, the proposed approach is not very effective for static systems.

Authors used the presented approach to model three systems of hair dryer, oil pump and brake system for electric cars to validate the generality and applicability of the approach. The perspective of this study is to analyse other types of uncertainty, such as model uncertainty, in the approach.

References

- [1] Elmaraghy, W., Elmaraghy, H., Tomiyama, T., Monostori, L., 2012, Complexity in engineering design and manufacturing, *CIRP Ann. - Manuf. Technol.*, vol. 61, pp. 793-814.
- [2] Weber, C., 2005, What Is 'Complexity?', *International conference on engineering design, ICED'05*, pp. 1-12.
- [3] ElMaraghy, W., Urbanic, R.J., 2003, Modelling of Manufacturing Systems Complexity, *CIRP Ann. - Manuf. Technol.*, vol. 52, no. 1, pp. 363-366.
- [4] Suh, N.P., 2005, Complexity in Engineering, *CIRP Ann. - Manuf. Technol.*, vol. 54, no. 2, pp. 46-63, Jan.
- [5] Suh, N.P., 2005, *Complexity - Theory and Applications*, OXFORD University Press.
- [6] Dantan, J.-Y., Qureshi, A.J., Antoine, J.-F., Eisenbart, B., Blessing, L.T.M., 2013, Management of product characteristics uncertainty based on formal logic and characteristics properties model, *CIRP Ann. - Manuf. Technol.*, vol. 62, no. 1, pp. 147-150.
- [7] Der Kiureghian, A., Ditlevsen, O., 2009, Aleatory or epistemic? Does it matter?, *Struct. Saf.*, vol. 31, no. 2, pp. 105-112.
- [8] Thunnissen, D.P., 2005, Propagating and mitigating uncertainty in the design of complex multidisciplinary systems, California Institute of Technology.
- [9] Walter, M., Storch, M., Wartzack, S., 2014, On uncertainties in simulations in engineering design: A statistical tolerance analysis application, *Simul. Trans. Soc. Model. Simul. Int.*, vol. 90, no. 5, pp. 547-559, May.
- [10] Pailhès, J., Sallaou, M., Nadeau, J.-P., Fadel, G.M., 2011, Energy Based Functional Decomposition in Preliminary Design, *J. Mech. Des.*, vol. 133, p. 051011.
- [11] Weber, C., 2005, CPM/PDD - An Extended Theoretical Approach to Modelling Products and Product Development Processes, *Proc. 2nd Ger. Isr. Symp. Adv. Methods Syst. Dev. Prod. Process.*, pp. 1-19.
- [12] Weber, C., 2007, Looking at 'DFX' and 'Product Maturity' from the Perspective of a New Approach to Modelling Product and Product Development Processes, *17th CIRP Design Conference: The Future of Product Development*, pp. 85-104.

- [13] Eisenbart, B., Blessing, L., Gericke, K., 2012, Functional Modelling Perspectives Across Disciplines: A Literature Review, *Proc. 12th Int. Des. Conf. Des.*, pp. 847-858, 2012.
- [14] Eisenbart, B., Gericke, K., Blessing, L., An analysis of functional modeling approaches across disciplines, 2013, *Artif. Intell. Eng. Des. Anal. Manuf.*, vol. 27, no. 03, pp. 281-289.
- [15] Suh, N.P., 2001, *Axiomatic Design - Advances and Applications*. OXFORD University Press.
- [16] Friedenthal, S., Moore, A., Steiner, R., 2012, *A practical Guide to SysML*, Second ed. Elsevier Inc.
- [17] Saltelli, A., Tarantola, S., Campolongo, F., Ratto, M., 2004, *Sensitivity Analysis in Practice: A Guide to Assessing Scientific Models*. John Wiley & sons, Ltd.
- [18] Saltelli, A., Ratto, M., Andres, T., Campolongo, F., Cariboni, J., Gatelli, D., Saisana, M., Tarantola, S., 2008, *Global Sensitivity Analysis - The primer*, John Wiley & sons, ltd.