

## MAS\_UP-UCT: A Multi-Agent System for University Course Timetable Scheduling

Mihaela Oprea

**Abstract:** Many real-world applications are mapped into combinatorial problems. An example of such problem is timetable scheduling. In this case, the two basic characteristics can be defined by its distributed and dynamic environment. One efficient solution to solve this problem could be provided by an agent-based approach. A timetable scheduling problem can be modelled as a multi-agent system that provides the final schedule by taken into account all the restrictions. In this paper it is presented a preliminary research work that involves the development of a multi-agent system for university course timetable scheduling, named MAS\_UP-UCT. We focus on the architecture of the multi-agent system, and on the evaluation of the communication process by using the interaction diagrams.

**Keywords:** Intelligent agents, Multi-agent systems, Timetable scheduling

### 1 Introduction

In the last decade, several Artificial Intelligence (AI) technologies and methods have been applied in the educational domain, at high school or university level. Most of the applications that use AI are solving the tutoring/teaching and/or examination tasks, while less of them try to solve also the administrative tasks (e.g. course timetabling, examination timetabling, students presence control, student registration) related to an educational institution. A recent developed educational system that models also such tasks is the e-Class Personalized prototype system presented in [10]. This system is an extension of the widely available open source Learning Content Management System, e-Class, which has a component named School administration, that deals with the tools that handle timetables, financial matters, personal student data, student registration etc. In this paper, we shall focus on the timetabling problem, and we shall discuss about MAS\_UP-UCT, an agent-based system that we have designed, which provide solutions to university course timetabling.

The general task of solving timetable scheduling problems is iterative and time consuming. In real world applications, the participants to the timetable scheduling have conflicting preferences, which make the search for an optimal solution an NP-hard problem. In order to solve the problem it is necessary to find a compromise between all the professors' requirements, usually conflicting (e.g. day, time). The constraints are related to the availability, timetabling and preferences of each professor, to rooms availability, number of students, and curricula. In order to solve this problem for the particular case of university course timetable scheduling we have adopted the agent-based approach. Multi-agents systems (MAS) are concerned with coordinating behavior among a collection of autonomous intelligent agents (e.g. software agents) that work in an environment. Sometimes, software agents are designed to reconcile their own interests with the constraints implied by other agents. One type of software agents is given by expert assistants who enable us to automate certain manual tasks and who work more efficiently. Expert assistant is a term given to an intelligent software agent that performs certain tasks on our behalf [15], [14]. For example, our daily organiser is an assistant. The complexity of multi-agent systems is generally higher than that corresponding to conventional software systems and their success rely on properly designed and well tested subsystems. Also, in the particular case of timetable scheduling, the MAS could find an optimal or a sub-optimal solution using mainly inter-agent communication (with minimal message passing).

In this paper, it is presented the architecture of a multi-agent system, MAS\_UP-UCT, that is under development, and has as main purpose the modelling of the university courses timetable scheduling. We

shall describe the architecture of the multi-agent system, focusing on the mapping of a course timetable scheduling in terms of intelligent agents, and finally, we shall make a preliminary evaluation of the multi-agent system.

## 2 University Course Timetabling Problem

The scheduling problem can be defined as a problem of finding the optimal sequence for executing a finite set of operations (tasks or jobs) under a certain set of constraints that must be satisfied. A scheduler usually attempts to maximize the utilization of individuals and/or resources and minimize the time required to complete the entire process being scheduled. There exist a number of different types of scheduling problems, such as job shop problems, sport leagues games scheduling, timetabling, service timetable problem for transportation networks, etc. Many scheduling problems share some features with the timetabling problem. In [12] it is presented a survey of automated timetabling. In the educational context, scheduling is the problem of assigning a set of events (courses and/or exams) to limited lengths of periods and to rooms, subject to certain conditions. There are two types of academic schedules: the course schedule and the examination schedule. For both types of problems the resources includes students, staff, rooms, courses, time, equipments. Several AI-based educational scheduling systems were reported in the literature (see e.g. the system presented in [13] for examination scheduling in universities). The formulation of the university course timetabling problem (as given in [4] and [12]) is the following:

Input data:  $q$  courses,  $K_1, \dots, K_q$ , for each  $i$ , course  $K_i$  consists of  $k_i$  lectures,  $r$  curricula which are groups of courses that have common students,  $S_1, \dots, S_r$ ,  $p$  - the number of periods,  $l_k$  - the maximum number of lectures that can be scheduled at period  $k$  (i.e. the number of rooms available at period  $k$ ).

Goal: find  $y_{ik}$  ( $i=1, \dots, q$ ;  $k=1, \dots, p$ ), so that

$$(1) \quad \sum_{k=1}^p y_{ik} = k_i$$

$$(2) \quad \sum_{i=1}^q y_{ik} \leq l_k$$

$$(3) \quad \sum_{i \in S_l} y_{ik} \leq 1$$

$$(4) \quad y_{ik} = 0 \text{ or } 1$$

where  $i=1, \dots, q$ ;  $l=1, \dots, r$ .

The constraints are the following: each course is composed by the correct number of lectures (relation (1)); each time there aren't more lectures than rooms (relation (2)); avoid conflicting lectures to be scheduled at the same period (relation (3)).

The objective function:  $\max \sum_{i=1}^q \sum_{k=1}^p d_{ik} y_{ik}$  where  $d_{ik}$  is the desiderability of having a lecture of course  $K_i$  at period  $k$ .

Different solutions, manual or automated, were proposed in the literature. Some automated solutions are given by tabu search [3], constraint satisfaction [12], genetic algorithms [2], logic programming [5], and combination of different methods [9].

### 3 The architecture of MAS\_UP-UCT system

We have designed the architecture of a multi-agent system, MAS\_UP-UCT, that tries to solve optimally the university courses timetable scheduling. In Figure 1 it is shown the architecture of the multi-agent scheduling system, while Figure 2 presents the general overview of the university course timetabling.

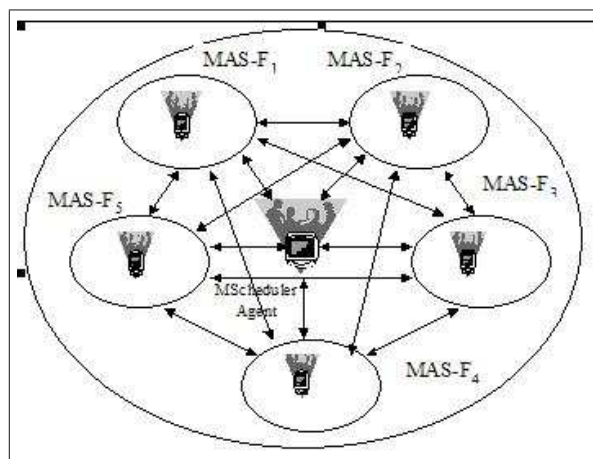

Figure 1: The architecture of MAS\_UP-UCT

We briefly describe how it is usually made the manual university course timetabling. Suppose the university includes five faculties, each of them having a number of specializations. The timetabling for each specialization is done by a person who is dedicated to this job, which we shall name specialization course scheduler. This person will provide five, four or three timetablings corresponding to the specialization's number of study years. The specialization course scheduler will receive a list of options from each professor that is teaching a course to a certain year of study at that specialization. The list of options will include the professor's options ordered by their desirability, and will include also, the list of impossible timetable schedulings. After course timetable scheduling is done at every faculty, it is started the activity of rooms allocation at university level.

So, the university course timetable scheduling problem is divided in two subproblems:

1. faculty course timetable scheduling (which involves only allocation of course day and time), and
2. university course rooms allocation (which involves allocation of rooms for courses).

When all courses have allocated time intervals (day and time) and rooms, the university course timetable scheduling is ended with success. Whenever a problem occur, it is started a communication process which will involve mainly a negotiation activity.

In most Romanian universities, the university course timetable scheduling is done either manually or partial automatically. In order to improve the efficiency of the whole activity, we have mapped the course timetabling in terms of autonomous intelligent agents. Each faculty has a scheduler multi-agent system (MAS-Fi), which has to schedule the courses of that faculty. The main scheduler agent (the university scheduler agent) which will allocate the rooms is MScheduler Agent. Because most professors teach courses to different faculties, every faculty scheduler agent has to communicate with the others scheduler agents, in order to solve some critical situations that may arise. The negotiation strategy used by the agents is similar to that described in [8]. In Figure 3 it is presented the MAS at faculty level, which includes a faculty scheduler agent, and expert assistants (EA) for each specialization of that faculty.

For each specialization it is developed an expert assistant which has to do all the activities connected with that specialization (e.g. evidence of students, course curricula etc). An important activity that should be done by an expert assistant is course timetable scheduling (day and time). A lot of constraints

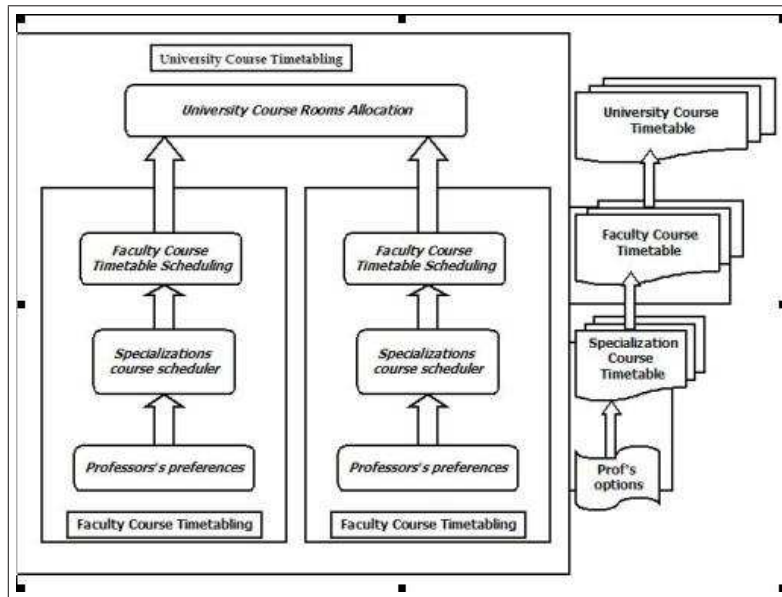

Figure 2: The general overview of the university course timetabling task

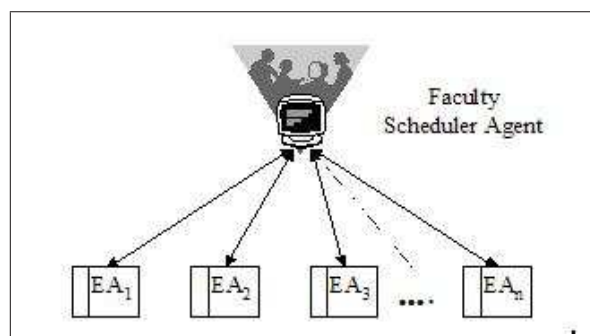

Figure 3: MAS-at faculty level

should be satisfied in order to solve the course timetabling. For example, one constraint is that all courses of a specialization are taught for all the groups of that specialization, and this constraint may become more severe in the case of courses that are taught for more than one specialization (this case appear for specializations that have courses with the same curricula). The faculty scheduler agents, who act autonomously, can schedule university course timetable on professor's individual behalf. Ideally, all profesor's preferences should be accepted. Unfortunately, we cannot reach an agreement among agents taking in consideration all professor's preferences. In course timetable scheduling, agents must quantify the professor's subjective preferences. In the worst cases (when a classical negotiation will have no results), we can reach a collective agreement by using a persuasion protocol (similar to that presented in [7]). The persuasion protocol is based on the rationality of agents. Agents should satisfy some criteria of rationality (e.g. maintaining logical consistency). The advantage is that negotiation using persuasion protocol can reach more agreements compared with existing negotiation protocols and it can improve the rate of agreement in course timetable scheduling.

The analysis and design phases of the MAS\_UP-UCT development were done by using the methodology Gaia v.2 [1]. In this methodology, during the design step three models are built: Agent Model, Service Model, and Acquaintance Model. The Agent Model specifies the types of agents that compose the system. Basically, the assignment of roles to agent types creates the Agent Model. The Service Model specifies the services that has to be implemented by the agent types. In Gaia, a service is a coherent block of functionality, neutral with respect to implementation details. The Acquaintance Model shows the communication links between agent types. Also, it is built a model of the environment. Summarizing, four types of agents are used by our system: Main Scheduler Agent (MSA), Faculty Scheduler Agent (FSA), Expert Assistant Agent (EAA), and Personal Agent (PA). Figure 4 shows the roles and responsibilities of each type of agent that compose the system MAS\_UP-UCT.

Type of agent (MAS_UP-UCT)	Roles
1. MSA	<b>scheduler</b> at the university level (responsibilities: allocation of rooms, negotiation activities)
2. FSA	<b>scheduler</b> at the faculty level (responsibilities: allocation of periods, integration of the schedules done at each specialization level, negotiation activities)
3. EAA	<b>scheduler</b> at the specialization level (responsibilities: allocation of periods, negotiation activities)
4. PA	<b>scheduler</b> for a professor teaching activity (responsibilities: allocation of periods, negotiation activities)

Figure 4: Roles for the agents that compose the system MAS\_UP-UCT

We make a brief discussion of two critical situations that may arise during a course timetabling: 1) at faculty course timetabling: day and time timetable conflict (two or more professor's options are identical) - Solution: start a negotiation process between the expert assistant of that specialization and the professors involved (or their personal agents). A message is sent by the specialization expert assistant to all those professors that are involved in a conflict, and will wait for a solution of the negotiation. If it will receive an answer it will do a rescheduling. If it will receive no solution, it will start a persuasion process of negotiation, suggesting a solution. 2) at university course timetabling: - no room is available for a certain day and time course. In this case the MScheduler agent will start a negotiation process between faculty scheduler agents that are involved in the conflict, by given some options. Each faculty scheduler involved in the conflict will pass the message to the corresponding expert assistants, or, in

some cases will continue to pass the message to professor's personal agents, who will then negotiate directly. If after this negotiation no solution will be found (e.g. some courses cannot be moved in other module or day), the main scheduler agent will start a persuasion dialog between the faculties agents that are in conflict, which in turn will transfer the problem at the lower level.

## 4 Evaluation of the multi-agent system

As an evaluation method of our MAS we have chosen the interaction diagram method [11]. An interaction diagram is a graph showing the processing of each agent symbolically as one or more vertical bars, and the messaging between agents as horizontal or oblique arrows between agents (from sender to receiver), decorated with message indications. In Figure 5 it is presented an example of interaction diagram, which illustrates a negotiation process at faculty level, between two expert assistants (EA<sub>i</sub> and EA<sub>j</sub>). In Figure 6 it is shown the interaction diagram in the case of a critical situation.

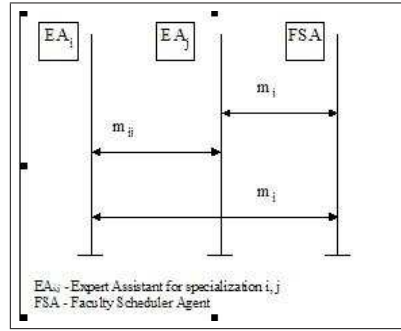

Figure 5: Example of interaction diagram

In order to evaluate the multi-agent system we can use interaction diagrams to design the communication process between agents (expert assistants, personal agents etc) and to verify that the system executes the correct communication sequences. We have used message flow fragmentation in order to realize an analysis of the communication process.

The direct sequence and a part of the inverse sequence of the message flow fragmentation that corresponds to the negotiation process shown in Figure 6 is given below.

$$\begin{aligned} & beg(MAS), beg(FSA_l), beg(FSA_k), beg(EA_{lt}), beg(EA_{lr}), beg(EA_{ki}), beg(EA_{kj}), \\ & snd(MAS, m_1), split(m_1, m_{1k}, m_{1l}), rcv(FSA_k, m_{1k}), rcv(FSA_l, m_{1l}), split(m_{1k}, m_{ki}, m_{kj}), \\ & split(m_{1l}, m_{lt}, m_{lr}), rcv(EA_{ki}, m_{ki}), rcv(EA_{kj}, m_{kj}), rcv(EA_{lt}, m_{lt}), rcv(EA_{lr}, m_{lr}), \\ & snd(EA_{ki}, m_{ki}^{-1}), snd(EA_{kj}, m_{kj}^{-1}), join(m_{ki}^{-1}, m_{kj}^{-1}, m_{1k}^{-1}), \dots, end(MAS), end(FSA_l), \\ & end(FSA_k), end(EA_{lt}), end(EA_{lr}), end(EA_{ki}), end(EA_{kj}) \end{aligned}$$

The inter-agent communication is done by using the agent language FIPA ACL. Figure 7 shows an example of such a message mA12 - EA-IME-AC exchanged during a negotiation.

Let's consider a course timetabling conflict at the level of a faculty. This conflict consists in the situation of day and time identical options for two professors (PA1, PA2) that teach at the same specialization (computer science) different courses. This situation is described in Figure 8.

Information exchanges during the conflict solve can be modeled with protocol diagrams using AUML notation [6]. Figure 8 shows a sample negotiation protocol for day and time timetable conflict solve. As it can be seen, the expert assistant of the computer science specialization (EACS) will inform the two personal agents corresponding to the two professors about the conflict. After this message is sent to both personal agents, between them it will start a negotiation protocol that involves a sequence of proposals and counter-proposals till a solution is accepted by the two agents. At the end of the negotiation process,

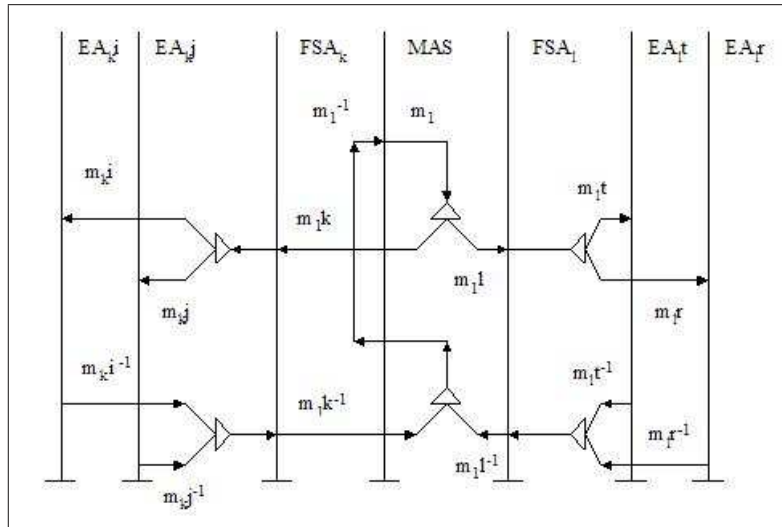

Figure 6: An example of negotiation in a critical situation

```

(inform
  :sender A12
  :receiver EAIME-AC
  :in-reply-to message3
  :content ((conflict Monday M2 IME-AC2 (course OOP))
            (options Monday (M3 M5 M7)
                      Tuesday (M1 M2)
                      Wednesday (M1-M5)
            ))
  :protocol fipa-iterated-contract-net-protocol
  :ontology univ_timetabling
  :language sl
)
    
```

Figure 7: Example of a FIPA ACL message

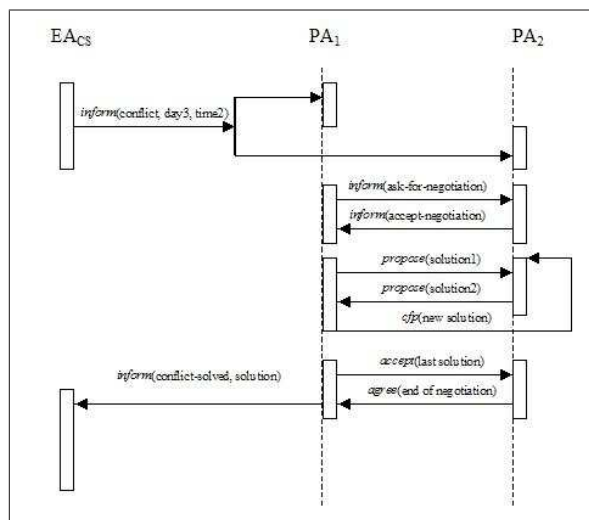

Figure 8: Negotiation protocol for a day and time conflict in course timetabling



PA1 will inform the expert assistant agent about the solution found.

## 5 Conclusion

The paper presented the current state of a research work that involve the development of a multi-agent system for university course timetable scheduling. The purpose of our work was to analyse the benefits of using an agent-based approach for the university course timetable scheduling, which involves a lot of communication, cooperation and negotiation processes. We have described the architecture of a multi-agent system for university course timetable scheduling, MAS\_UP-UCT, and briefly discussed about the evaluation of the multi-agent system.

We can conclude that the main benefits of the agent-based approach adopted for university course timetabling are given by the possibility of doing negotiation between agents as a solution to the conflicts that may arise, and by the analysis of the exchanged messages flow between agents with the interaction diagrams.

## References

- [1] L. Cernuzzi, T. Juan, L. Sterling, F. Zambonelli, The Gaia methodology - Basic Concepts and Extensions, *Methodologies and Software Engineering for Agent Systems*, eds. Bergenti, F., Gleizes, M.-P., Zambonelli, F., Kluwer Academic Publishers, pp. 69-88, 2004.
- [2] D. Corne, P. Ross, H.-L. Fang, Fast practical evolutionary timetabling, *Lecture Notes in Computer Science*, LNCS 865, pp. 251-263, 1994.
- [3] D. Costa, A tabu search algorithm for computing an operational timetable, *European Journal of Operational Research*, vol. 76, pp. 98-110, 1994.
- [4] D. de Werra, An Introduction to Timetabling, *European Journal of Operational Research*, vol. 19, pp. 151-162, 1985.
- [5] R. Fahrion, G. Dollanski, Construction of university faculty timetables using logic programming techniques, *Discrete Applied Mathematics*, vol. 35, no. 3, pp. 221-236, 1992.
- [6] M. -F. Huget, J. Odell, B. Bauer, The AUML Approach, *Methodologies and Software Engineering for Agent Systems*, eds. Bergenti, F., Gleizes, M.-P., Zambonelli, F., Kluwer Academic Publishers, pp. 237-257, 2004.
- [7] T. Ito, T. Shintani, An Agenda-scheduling System Based on Persuasion Among Agents, *Technical report: Nagoya Institute of Technology*, 1997.
- [8] M. Oprea, The Use of Adaptive Negotiation by a Shopping Agent in Agent-Mediated Electronic Commerce, *Lecture Notes in Artificial Intelligence*, LNAI 2691, Springer-Verlag, Berlin Heidelberg, pp. 594-605, 2003.
- [9] G. Picard, C. Bernon, M.-P. Gleizes, Cooperative Agent Model within ADELFE Framework An Application to a Timetabling Problem, *Proceedings of The 3rd International Joint Conference on Autonomous Agents and Multi Agent Systems*, New York, USA, pp. 1506-1507, 2004.
- [10] E. G. Prodromou, N. Avouris, e-Class Personalized: Design and Evaluation of an Adaptive Learning Content Management System, *Artificial Intelligence Applications and Innovations*, eds. Maglogiannis, I., Karpouzis, K., Bramer, M., Springer, pp. 409-416, 2006.



- [11] R. Ronnquist, C. K. Low, Analysing Expert Assistants through Interaction Diagrams, *Proceedings of Autonomous Agents 97*, ACM Press, pp. 500-501, 1997.
- [12] A. Schaerf, A survey of automated timetabling, *Technical report: CS-R9567*, Centrum voor Wiskunde en Informatica, 1995.
- [13] C. C. Wei, A. Lim, Automated Examination Scheduling Problem, *Proceedings of the IASTED International Conference Applied Informatics*, Innsbruck, ACTA Press, pp. 93-96, 2002.
- [14] G. Weiss, *Multiagent systems*, The MIT Press, Cambridge, Massachusetts, 1999.
- [15] M. Wooldridge, N. R. Jennings, Intelligent agents: theory and practice, *The Knowledge Engineering Review*, vol. 10, no. 2, pp. 115-152, 1995.

Mihaela Oprea  
University Petroleum-Gas of Ploiesti  
Department of Informatics  
Address: B-dul Bucuresti 39, 100680  
Ploiesti, Romania  
E-mail: mihaela@upg-ploiesti.ro  
Received: November 8, 2006

**Editor's note about the author:**



Mihaela OPREA (born on February 20, 1967) graduated the Faculty of Automatics and Computer Science at the University Politehnica Bucharest in 1990, and got her PhD at the Department of Automatics and Computer Science of the University Petroleum-Gas of Ploiesti in 1996. Currently, she is a full professor at the Department of Informatics of the University Petroleum-Gas of Ploiesti. Her main research interests include pattern recognition algorithms, machine learning, knowledge modelling, applications of multi-agent systems and artificial intelligence techniques in various domains such as environmental protection, engineering, and education. She has published more than 70 research papers in the area of artificial intelligence in international journals, and in the proceedings of prestigious international conferences, printed by important publishers (Springer, Kluwer Academic, IOS Press, IEEE Computer Society Press). Since 1995 she has visited as a research visitor universities and artificial intelligence research institutes from UK, Austria, Spain, Greece, Sweden, Czech Republic, Hungary, and France. She is a member of some professional associations, and of the international programme committees of several conferences held in Europe, USA, Canada, South America, also participating at some of them as a tutorial presenter.