



Please cite the Published Version

Enahoro, S, Ekpo, S  and Gibson, A  (2022) Massive Multiple-Input Multiple-Output Antenna Architecture for Multiband 5G Adaptive Beamforming Applications. In: 2022 IEEE 22nd Annual Wireless and Microwave Technology Conference (WAMICON), 27 April 2022 - 28 April 2022, Clearwater, Florida, USA.

DOI: <https://doi.org/10.1109/WAMICON53991.2022.9786100>

Publisher: IEEE

Version: Accepted Version

Downloaded from: <https://e-space.mmu.ac.uk/630103/>

Additional Information: © 2022 IEEE. Personal use of this material is permitted. Permission from IEEE must be obtained for all other uses, in any current or future media, including reprinting/republishing this material for advertising or promotional purposes, creating new collective works, for resale or redistribution to servers or lists, or reuse of any copyrighted component of this work in other works.

Enquiries:

If you have questions about this document, contact rsl@mmu.ac.uk. Please include the URL of the record in e-space. If you believe that your, or a third party's rights have been compromised through this document please see our Take Down policy (available from <https://www.mmu.ac.uk/library/using-the-library/policies-and-guidelines>)

Massive Multiple-Input Multiple-Output Antenna Architecture for Multiband 5G Adaptive Beamforming Applications

Sunday Enahoro
Department of Engineering
Manchester Metropolitan University
Manchester, United Kingdom
Sunday.enahoro@stu.mmu.ac.uk

Sunday Ekpo
Department of Engineering
Manchester Metropolitan University
Manchester, United Kingdom
Sunday.ekpo@mmu.ac.uk

Andy Gibson
Department of Engineering
Manchester Metropolitan University
Manchester, United Kingdom
A.Gibson@mmu.ac.uk

Abstract—One major challenge to full 5G systems deployment especially in mm-Wave band is the poor signal propagation. One approach to mitigate this effect is the use of new 5G technologies such as massive MIMO, adaptive beamforming, reconfigurable antennas etc. which can enhance the performance of the system. Adaptive beamforming algorithm uses advance digital signal processing techniques to generate main beams in the direction of interest while placing nulls in interfering signals direction to reduce interference. The beams are formed in the receiver rather in free space. It is therefore very crucial to develop an algorithm that can optimize the system to improve performance by generating signals at a faster convergence rate.

In this paper, the performance analysis of various adaptive beamforming systems for 5G applications are presented using various LMS algorithms including a novel sign-leaky LMS algorithm. A uniform linear array antenna of varying element configurations, inter-element spacing, varying step-size, direction of arrival angles of the desired signals are analysed using various algorithms to determine the optimum performance of the systems. Simulation result shows that the convergence rate is highly enhanced, with the proposed algorithm converging with at least 5 iterations less than conventional LMS algorithm, while reducing interference effects by placing deeper nulls in interfering signal direction of arrivals using the proposed beamforming algorithm. There is also at least -2 dB drop in normalized power of the sidelobe level compared to the LMS algorithm.

Keywords—Adaptive beamforming (ABF), Least Mean Square (LMS), Leaky-LMS, Null Depth, Uniform Linear Array (ULA), massive MIMO (m-MIMO).

I. INTRODUCTION

In present and future wireless communication technology, high data rate, high SNR, high signal integrity and high bandwidth are essentially the ultimate goal of a communication system network. These characteristic performances decrease as the number of users in a communication system network increases [2]. To address these challenges, 5G technologies are being implemented and is expected to provide a significant increase usage of the present communication system. It will also provide connectivity link between machines (IoT) and people [4, 5], provide support for remote healthcare applications,

autonomous self-driving vehicles and virtual/augmented reality (VR/AR) [6, 7]. Massive antenna array deployment also help to mitigate some of these challenges while enhancing data transfer in wireless communication channel by exploiting spatial diversity [1, 11]. The use of beamforming technique considerably improves the channel propagation characteristics as well as the coverage area since the antenna array signals are combined at the transceiver in mmWave application. [1, 2].

The formation of the antenna beam pattern using digital signal processor (DSP) is known as digital beamforming [13], referred to as adaptive beamforming when adaptive algorithms are used.

The major challenge in implementing fully digital beamforming transceiver system is the hardware complexity, excessive power consumption and high overhead cost, because separate RF chains are required for each antenna element. These DBF limitations makes analog and hybrid beamforming still very attractive. Some practical solutions [8, 13, 18-22] have been proffered to address some of these challenges in recently investigated scenarios. The use of multiple-input-multiple-output (MIMO), reconfigurable antenna, adaptive beamforming technology and spatial processing [9] are also proposed. Amongst the digital beamforming algorithms available in literature, LMS beamforming algorithm has been widely used due to its low computational complexity and knowledge of signals direction-of- arrival (DOA). It is used to adjust the beamforming vector weights to form narrow beams of accurate directivity in order to optimize performance according to required criteria [12, 13]. Such optimization criteria could be to minimize variance, minimize the mean square error (MSE), nulling interfering signal, steering toward signal of interest or tracking an emitter [2, 14].

II. MASSIVE MIMO ANTENNA ARRAY ANALYSIS

MIMO technology improves communication system data rate performance using spatial multiplexing. Multiple antennas are used to transmit and receive each signal which share the same frequency. A general MIMO system is shown Figure 1 with N transmit and M receive antennas. If we consider a flat-fading channel condition and define an N -element complex transmit array vector created by the N -transmit array as

$$\bar{s} = [s_1 \ s_2 \ \dots \ s_N]^T \quad (1)$$

Where N is the transmit antenna elements and connects to the receive antenna, M through a single or multiple paths creating

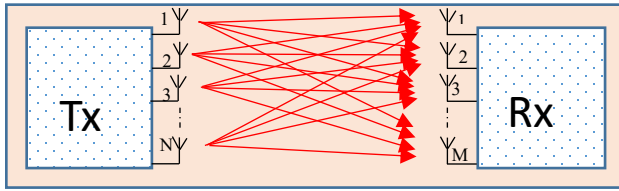

Fig. 1: Basic structure of a MIMO

a channel transfer matrix h_{mm} . The $N \times M$ complex channel matrix can then be defined as:

$$\bar{H} = \begin{bmatrix} h_{11} & h_{12} & \dots & h_{1M} \\ h_{21} & h_{22} & \dots & h_{2M} \\ \vdots & \vdots & \ddots & \vdots \\ h_{N1} & h_{N2} & \dots & h_{NM} \end{bmatrix} \quad (2)$$

Considering the downlink transmission, we assume that the transmit array sends complex signals to all k users. These transmitted signals are represented by

$$\bar{x} = [x_1 \ x_2 \ \dots \ x_N]^T \quad (3)$$

The signal received by the k -th user is then given by:

$$y = \sum_{k=1}^K \sqrt{h_k x_k P_k} + n \quad \dots \dots \dots (4)$$

where P_k represent the k -th user transmit power, x_k is the transmitted signal vector and n is the noise vector.

The received signal (Eq. 4) can be represented in compact form as:

$$y = HPx + n \quad (5)$$

where x is the $N \times 1$ transmitted signal vector and n represents the $M \times 1$ additive noise vector.

III. MASSIVE MIMO RF FRONT-END SUBSYSTEMS

Digital beamforming allows beams to be formed in the RF subsystem and the beams directed in specific ways. This beamforming techniques tends to increase the number of RF sub-networks and antennas. The RF front-end consists of transmitters and receiver blocks, digital signal processors, a radio distribution network and antennas array. Figure 2 shows a high-level digital beamforming RF front-end receiver module. Each transceiver is connected to specific antenna or antenna arrays.

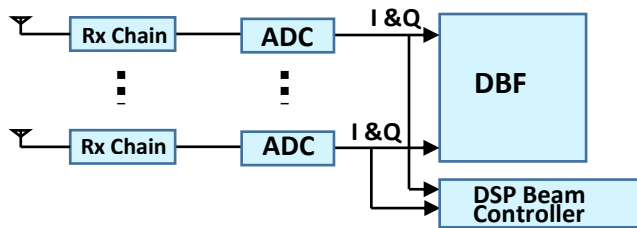

Fig 2: Receiver Digital beamforming architecture

The signal chain formed for each antenna element are fed to a DBF system, which in principle can form as many beams as possible. The weight value of the RF signal is given by

$$w_k = \frac{1}{\sqrt{k}} \exp(-j\frac{2\pi}{\lambda}(k-1)d_v \cos \theta) \quad \text{for } k=1, 2, \dots, K \quad (6)$$

where $K = \frac{M}{M_{Tx}}$, wavelength = λ , zenith angle = θ , and d_v is the inter-element spacing.

IV. SYSTEM MODEL

Assume a uniform linear array (ULA) of Fig. 3 comprising of N -elements, on which K plane wave narrowband source impinges from directions θ_i . At the n th element, the received signal is represented as:

$$x_i(t) = \sum_{i=1}^N s_i(t) e^{-j(i-1)k_i} + n_i(t) \quad (7)$$

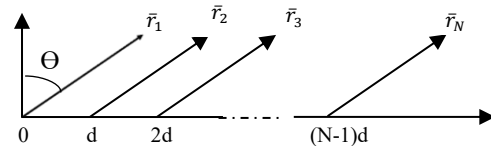

Fig. 3: Uniform M-Element Linear Array

where N is the isotropic element antennas used to depict a uniformly spaced linear array, $s_i(t)$ is the signal of the i -th source, and $n_i(t)$ is the uncorrelated white noise received at the i -th element respectively. Also $k_i = \frac{2\pi d}{\lambda} \sin(\theta_i)$.

If far field condition is assumed such that $r \gg d$, the array factor can be derived as:

$$AF(\theta) = 1 + e^{j(kd \sin \theta + \delta)} + e^{j2(kd \sin \theta + \delta)} + e^{j3(kd \sin \theta + \delta)} + \dots + e^{j(N-1)(kd \sin \theta + \delta)} \quad (8)$$

where δ is the inter-element phase shift, d is the distance between element, θ is the angle direction and $k = 2 * \pi / \lambda$. Eq. 11 can be more precisely expressed as:

V. 5G ADAPTIVE BEAMFORMING

Beams are information generated and accumulated from a transmit/receive antenna. Beamforming is a basic spatial or

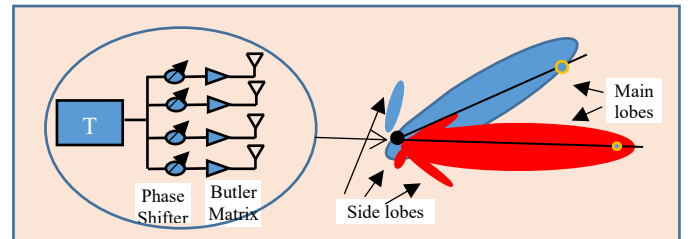

Fig. 4: Beamforming using four transmit antennas adaptive filtering concept. The most useful characteristics of adaptive beamforming is its ability to track signals in a dynamic and complex environment using optimum weights. These optimum weights vectors are generated using selective adaptive

beamforming algorithms [13]. Some of such beamforming algorithms are discussed next.

A. Least Mean Square (LMS) Algorithm

LMS algorithm, a gradient-based and non-blind optimisation method uses a steepest-descent technique to continuously compute and update vector weights that require a training sequence [14]. The array output weights are computed thus:

$$\bar{w}(k+1) = \bar{w}(k) + \mu e(k) \cdot \bar{x}(k) \quad (9)$$

where $x(k)$ is the reference input signal, μ is a convergence factor (or step-size) that controls rate of convergence and stability. The larger the step-size value, the faster the convergence and $e(k)$ is the error signal given by:

$$e(k) = d(k) - \bar{w}^H(k) \bar{x}(k) \quad (10)$$

where H is the Hermitian transpose vector and μ , the step size parameter. The LMS algorithm parameter's convergence is directly proportional to the step size parameter.

B. Normalized Least Mean Square (NLMS) Algorithm

LMS algorithm convergence speed depends on the input signal power, which makes LMS system independent. Signal normalization is introduced to make the system independent. The NLMS algorithm weight coefficient is expressed as

$$\bar{w}(k+1) = \bar{w}(k) + \frac{\mu}{\|\bar{x}(k)\|^2} e(k) \cdot \bar{x}(k) \quad \dots \dots (11)$$

C. Leaky Least Mean Square (Leaky-LMS) Algorithm

Leaky LMS algorithm is one type of LMS variant. LMS slow convergence drawback slows down the system as a result of higher Eigen values. Leaky LMS can be used to reduce numeric errors accumulated in the weights coefficient and it provide compromise between weight coefficient energy and minimising the mean square error. The leaky LMS algorithm is expressed as:

$$\bar{w}(k+1) = v \bar{w}(k) + \mu e(k) \cdot \bar{x}(k) \quad (12)$$

where v is the leakage factor with $0 \leq v \leq 1$, higher value causes more error, and the algorithm does not converge.

D. Proposed Algorithm

The proposed novel algorithm namely Sign-Leaky LMS is introduced in this section. The optimised coefficient weight vectors are applied at each antenna element received steering signal vectors in the linear array.

The weighted signals arrays are collected at the output to generate beams in the direction of interest and null interfering signals. Block diagram of the adaptive beamforming system is shown in Figure 5.

$$y(k) = w_K^H \cdot x(k) \quad (13)$$

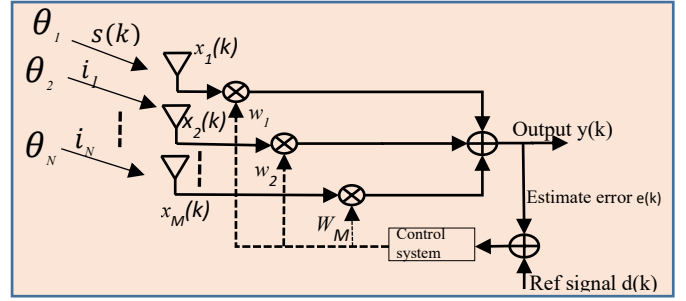

Fig. 5: MSE adaptive system

where the weights are given by $w = \{w_1, w_2, \dots, w_k\}$. The optimisation weights are selected in order to suppress noise or interference like jammer signals or clutter. H is a Hermitian transpose. The input signal is represented as $x(k) = \{x_1, x_2, \dots, x_k\}$

Our problem definition is to find an optimisation weight vector that will cancel out interference by placing deeper null at the arrival angle and providing the desired signal maximum power while also providing the system a faster convergence rate.

Modifying the leaky LMS algorithm, we obtain

$$\bar{w}(k+1) = (1 - \mu\varphi) \cdot \bar{w}(k) + \mu e(k) \cdot \text{sgn}(\bar{x}(k)) \quad (14)$$

The signum function is given as

$$\text{sgn}\{x(k)\} = \begin{cases} 1 & x(k) > 0; \\ 0 & x(k) = 0; \\ -1 & x(k) \leq 0; \end{cases}$$

where μ is the step-size, $\varphi \ll 1$, is the leakage factor.

$e(k)$ is the error function given by $e(k) = d(k) - y(k)$, $d(k)$ is the desired reference signal and $y(k)$ is the output signal.

VI. SIMULATION RESULTS AND DISCUSSION

Computer simulations are carried out using Matlab (Mathworks) simulation software to investigate the performances of the presented algorithms. Initially, eight elements uniform linear array with inter-element spacing of half-wavelength were used. A desired user signal arrival angle (DOA = 0°) and two interfering signal with signal arrival angles of -30° and +30° were utilized for convenience. The mean square error between the output signal and the desired signal, the normalized power of the signal of interest and the beam pattern of the array against the DOA angles are used to measure the system performance.

Figures 6 – 9 shows the performances comparison of the various adaptive beamforming algorithms (LMS, NLMS, Leaky LMS, Sign-Error LMS) with the proposed modified LMS (sign-Leaky) beamforming algorithm. Figures 7 and 8 shows the response beam pattern (signal power versus direction angle plot) of the proposed algorithm and various modified LMS algorithm with the desired signal pointing to maximum at 0° while the two interferers are nulled at -30° and +30° respectively. In Figure 7, the proposed algorithm sidelobe

levels drop by at least -2 dB with 8 antenna elements as compared to that of LMS and the other variants. There is a deeper null placement at -30° and $+30^\circ$ of -45dB and -35dB for the proposed algorithm compared to -36 dB and -34 dB of the LMS algorithm with 8 antenna elements. Simulation results clearly shows that the beam patterns of the proposed algorithm generate its maximum gain along the direction of target user, while the gain towards each interferer is relatively much lower (deep nulled).

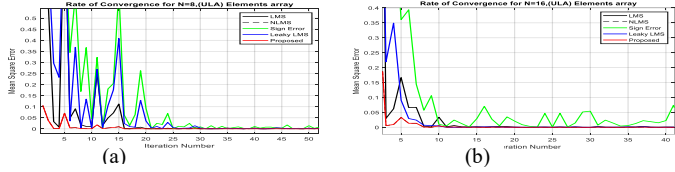

Fig. 6: Mean Square Error of various Algorithm comparison

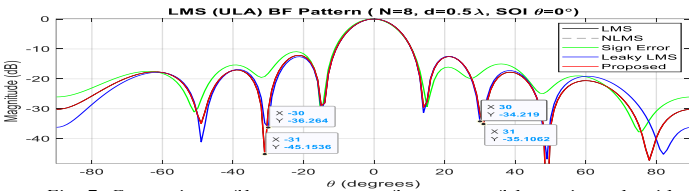

Fig. 7: Comparison of beam pattern performances of the various algorithm with $N=8$, $d=0.5\lambda$, $\theta_i=0^\circ$ with two interferers at -30° and $+30^\circ$

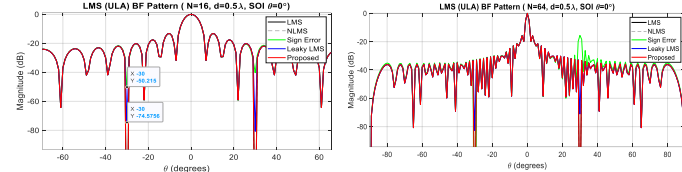

Fig. 8: Comparison of beam pattern performances of the various algorithm with $N=16$, $d=0.5\lambda$, $\theta_i=0^\circ$ with two interferers at -30° and $+30^\circ$

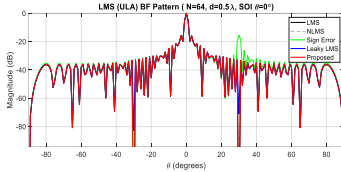

Fig. 9: Comparison of beam pattern performances of the various algorithm with $N=64$, $d=0.5\lambda$, $\theta_i=0^\circ$ with two interferers at -30° and $+30^\circ$

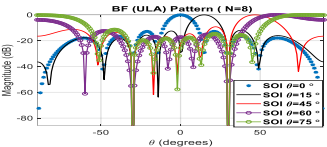

Fig. 10: Array pattern of proposed algorithm at various desired signal scan angle with $N=8$, $d=0.5\lambda$, and two interferers at -30° and $+30^\circ$

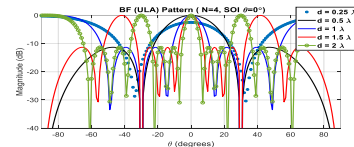

Fig. 11: Beam pattern of proposed algorithm with various inter-element spacing with $N=4$, with scan angle at 0° and two interferers at -30° and $+30^\circ$

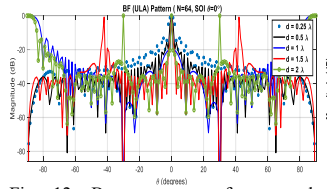

Fig. 12: Beam pattern of proposed algorithm with various inter-element spacing with $N=64$, with scan angle at 0° and two interferers at -30° and $+30^\circ$

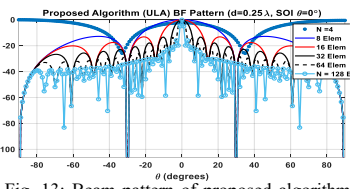

Fig. 13: Beam pattern of proposed algorithm with various antenna element, $d=0.25\lambda$, scan angle at 0° and two interferers at -30° and $+30^\circ$

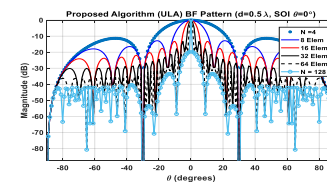

Fig. 14: Beam pattern of proposed algorithm with various antenna element, $d=0.5\lambda$, scan angle at 0° and two interferers at -30° and $+30^\circ$

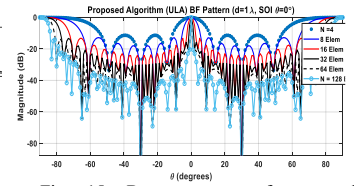

Fig. 15: Beam pattern of proposed algorithm with various antenna element, $d=1\lambda$, scan angle at 0° and two interferers at -30° and $+30^\circ$

VII. CONCLUSION

This paper investigated and proposed a new adaptive beamforming algorithm that is suitable for new 5G technology applications. Evaluated simulation results shows that the proposed algorithm exhibits high convergence and tracking properties at the desired signal arrival angle than conventional LMS algorithm. The beamforming algorithm in combination with reconfigurable massive MIMO antenna will enhance 5G performance.

VIII. REFERENCES

- [1] S. Ekpo, B. Adebisi and A. Wells, "Regulated-Element Frost Beamformer for Vehicular Multimedia Sound Enhancement and Noise reduction Applications", IEEE Access, vol. 5, pp. 27254-27262, 2017. DOI: 10.1109/access.2017.2775707.
- [2] S. Enahoro, S. Ekpo, M. Uko, A. Altaf, U. Ansari and M. Zafar, "Adaptive Beamforming for mmWave 5G MIMO Antennas", 2021 IEEE 21st Annual Wireless and Microwave Technology Conference (WAMICON), pp. 1-5, 2021. DOI: 10.1109/wamicon47156.2021.9443616.
- [3] M. Ali, O. Haraz, S. Alshebeili, and A. R. Sebak, "Broadband printed slot antenna for the fifth generation (5G) mobile and wireless communications," in 2016 17th International Symposium on Antenna Technology and Applied Electromagnetics (ANTEM), July 2016, pp. 1–2. [EEE]
- [4] D. Fang, Y. Qian and R. Hu, "Security for 5G Mobile Wireless Networks", IEEE Access, vol. 6, pp. 4850-4874, 2018. DOI: 10.1109/access.2017.2779146.
- [5] J. G. Andrews, S. Buzzi, W. Choi, et al. What will 5G be?. IEEE J. Selected Areas Communication. 2014;32(6):1065–82.
- [6] Q. Abbasi, S. Jilani, A. Alomayni and M. Imran, *Antennas and propagation for 5G and beyond*. London: IET, 2020.
- [7] K. Simovska, "5G NEW RADIO (5G NR) - AIR INTERFACE IN 5G MOBILE NETWORKS", Journal of Electrical Engineering and Information Technologies, vol. 6, no. 1, pp. 37-48, 2021. DOI: 10.51466/jeeit2161184037s.
- [8] E. Bjornson, L. Van der Perre, S. Buzzi and E. Larsson, "Massive MIMO in Sub-6 GHz and mmWave: Physical, Practical, and Use-Case Differences", IEEE Wireless Communications, vol. 26, no. 2, pp. 100-108, 2019. DOI: 10.1109/mwc.2018.1800140.
- [9] 5G Americas Advanced Antenna Systems for 5G. 5G Americas; 2019
- [10] Ericsson Mobility Report. Ericsson, Sweden; 2018.
- [11] V. Kaim, B. Kanaujia and K. Rambabu, "Quadrilateral Spatial Diversity Circularly Polarized MIMO Cubic Implantable Antenna System for Biotelemetry", IEEE Transactions on Antennas and Propagation, vol. 69, no. 3, pp. 1260-1272, 2021. doi: 10.1109/tap.2020.3016483.
- [12] Z. Chen, *Handbook of Antenna Technologies*. Singapore: Springer Singapore, 2015.
- [13] A. P. RAO, N. SARMA, Adaptive Beamforming Algorithms for Smart Antenna Systems. WSEAS TRANSACTIONS on COMMUNICATIONS 2014, , 44-50
- [14] F. Gross, Smart antennas with MATLAB®, Second Edition. New York, N.Y.: McGraw-Hill Education LLC, 2015.
- [15] C. Balanis, Antenna theory: Analysis and Design. Hoboken, N.J.: Wiley, 2016.
- [16] E. Bjornson, E. Larsson and T. Marzetta, "Massive MIMO: ten myths and one critical question", IEEE Communications Magazine, vol. 54, no. 2, pp. 114-123, 2016. doi: 10.1109/mcom.2016.7402270.
- [17] H. Kim, Design and optimization for 5G wireless communications, 1st ed. West Sussex: Wiley, 2020.
- [18] D. Qiao, X. Yang, W. Tan, C. Wen and S. Jin, "Low-Cost Massive MIMO: Pilot Length and ADC Resolution", Journal of Communications and Information Networks, vol. 3, no. 2, pp. 23-36, 2018. DOI: 10.1007/s41650-018-0020-7.