

NASA  
Technical Memorandum 105790

AVSCOM  
Technical Report 92-C-004

1N-37  
105215

P. 17

# Maximum Life Spiral Bevel Reduction Design

M. Savage and M.G. Prasanna  
*University of Akron*  
*Akron, Ohio*

and

H.H. Coe  
*Lewis Research Center*  
*Cleveland, Ohio*

(NASA-TM-105790) MAXIMUM LIFE  
SPIRAL BEVEL REDUCTION DESIGN  
(NASA) 17 p

N93-10982

Unclass

G3/37 0125215

479924

Prepared for the  
28th Joint Propulsion Conference and Exhibit  
cosponsored by the AIAA, SAE, ASME, and ASEE  
Nashville, Tennessee, July 6-8, 1992

**NASA**





# MAXIMUM LIFE SPIRAL BEVEL REDUCTION DESIGN

M. Savage and M.G. Prasanna  
The University of Akron  
Akron, Ohio

H.H. Coe  
National Aeronautics and Space Administration  
Lewis Research Center  
Cleveland, Ohio

## SUMMARY

Optimization is applied to the design of a spiral bevel gear reduction for maximum life at a given size. A modified feasible directions search algorithm permits a wide variety of inequality constraints and exact design requirements to be met with low sensitivity to initial values. Gear tooth bending strength and minimum contact ratio under load are included in the active constraints. The optimal design of the spiral bevel gear reduction includes the selection of bearing and shaft proportions in addition to gear mesh parameters. System life is maximized subject to a fixed back-cone distance of the spiral bevel gear set for a specified speed ratio, shaft angle, input torque and power. Significant parameters in the design are: the spiral angle, the pressure angle, the numbers of teeth on the pinion and gear and the location and size of the four support bearings. Interpolated polynomials expand the discrete bearing properties and proportions into continuous variables for gradient optimization. After finding the continuous optimum, a designer can analyze near optimal designs for comparison and selection. Design examples show the influence of the bearing lives on the gear parameters in the optimal configurations. For a fixed back-cone distance, optimal designs with larger shaft angles have larger service lives.

## INTRODUCTION

Spiral bevel gears are complex machine elements which operate kinematically in three-dimensions to transmit power at high-speeds between intersecting shafts. The spiral angle enables the gears to transmit power more quietly than straight bevel gears, just as helical gears operate more quietly than spur gears. Bevel gears convert the high-speed power of horizontal gas turbine engines into the nearly vertical power of the main rotor masts in all helicopter transmissions. Aircraft transmissions are one of the more critical applications of bevel gearing due to the high-speed, high-power, and light-weight requirements.

Although the design of bevel gears has evolved over several centuries (ref. 1), it has focused recently on the load capacity, meshing kinematics, and manufacturing requirements of the gears (refs. 2 to 12). Due to its importance and complexity, a significant effort has been extended to model the meshing kinematics of spiral bevel gears (refs. 3, 4, and 6 to 8). Although the design of a spiral bevel gear set must include this information, it also should include considerations of gear tooth (refs. 9 to 11) and bearing load capacity. In this work, considerations of the support bearing capabilities are included at the time the gear parameters are chosen.

Optimization theory offers designers this capability (ref. 13). One approach to optimization is to find the intersections of the active design constraints. The optimal design is often found at a trade-off point on the constraint boundaries. A constraint intersection technique has been applied to design light-weight spur gear sets (ref. 14). Although powerful, this technique is limited to problems with only two or three active design variables.

More recently, a modified feasible directions gradient search technique has been applied to the same spur gear design problem with equal success (ref. 15). One significant advantage of the gradient technique is its multi-dimensional search capability. Larger problems which include simultaneous optimization of interacting components can be treated with this technique.

This paper applies the modified feasible directions gradient search technique to the problem of designing a spiral bevel reduction to transmit a specified power at a specified input speed with a given reduction ratio, shaft angle, and reduction size. The optimization criterion is maximum system life based on a two-parameter Weibull system life model which includes the lives of the bearings and the gears (ref. 16).

In the model, each gear is supported by a ball and a straight roller bearing mounted behind the gear with the roller bearing being closest to the gear. The independent design parameters include the mesh face width, the number of pinion teeth, the normal pressure angle, the mesh spiral angle, and the shaft diameters. The diametral pitch of the gears is dependent on these parameters. Inequality constraints restrict the gears to have adequate tooth bending and pitting strengths, tooth scoring resistance, avoidance of involute interference, and adequate contact ratios. Adequate room for the bearing envelopes and consistency of shaft sizes for the gears and bearings provide additional constraints for the model.

The gradient search occurs in a continuous design space which is generated by polynomial fits to discrete bearing data and the mathematical willingness to have fractional teeth on the gears. Once a continuous mathematical optimum is found, the optimization program allows the designer to enter one or several alternate designs with more practical proportions for comparative evaluations. A full analysis is conducted for the initial optimal design and all selected alternative designs.

To demonstrate the procedure, the shaft angle is varied for a bevel gear design problem of fixed speed and power level at a fixed gear ratio with the same back-cone distance and shaft lengths. Optimum designs at different shaft angles are compared.

## NOMENCLATURE

A	distance from inboard roller bearing to gear or pinion, in.
a	addendum, in.
$A_0$	back-cone distance, in.
B	distance from outboard ball bearing to gear or pinion, in.
b	Weibull slope
C	dynamic capacity, lb
$C_0$	design constant vector
D	shaft diameter, mm
d	dedendum, in.

$e_f$	goodness of fit error limit
F	force, lb
f	gear face width, in.
$\nabla f$	unit gradient in the feasible direction
$\nabla h$	unit gradient in the violated constraints
J	AGMA bending strength tooth form factor
$K_v$	dynamic load velocity factor
$\ell_{av}$	mean service life, hr
$\ell_{10}$	90 percent reliability life, hr
M	merit function
$\nabla M$	gradient in the merit function
$\nabla m$	unit gradient in the merit function
N	number of teeth
n	gear reduction ratio
$P_d$	diametral pitch, in. <sup>-1</sup>
p	load life factor
$\Delta S$	optimization step size
V	inequality constraint vector
$\nabla V$	gradient in an inequality constraint
$\nabla v$	unit gradient in an inequality constraint
X	independent design parameter
Y	scaled independent design parameter
$\Gamma$	cone angle, deg
$\Gamma$	gamma function
$\Sigma$	shaft angle, deg

- $\sigma$  stress, psi
- $\phi$  pressure angle, deg
- $\psi$  spiral angle, deg

Subscripts:

- a active
- g gear
- j optimization step index
- k constraint index
- p pinion
- t tangential

### Spiral Bevel Reduction Model

Figure 1 is a schematic of the spiral bevel model for this design study. The figure includes most of the basic parameters which define a bevel gear set. It shows the geometry of this study in which both gears are supported in overhung configurations. The gears are described by:

1. the shaft angle,  $\Sigma$ ;
2. the gear ratio,  $n$ ;
3. the number of teeth on the pinion,  $N_p$ ;
4. the back-cone distance of the mesh,  $A_o$ ;
5. the face width,  $f$ ;
6. the normal pressure angle,  $\phi$ ; and
7. the mesh spiral angle,  $\psi$ .

The bearings are described by their:

1. type;
2. series;
3. distances from the supported gear, A and B; and
4. shaft size, D.

The bearings may be either ball or straight roller and the series may be extra-light, 100; light 200; or medium 300. For the examples of this work, the bearings closest to the gears are straight roller bearings and the far bearings are ball bearings. The roller bearings are placed directly behind the gears with a small axial clearance equal to a proportion of the bearing and gear widths. And the ball bearings are placed at the ends of the support shafts. Both bearings on the same shaft have the same bore, which is kept smaller than the inside rim of the gear. This places the stronger roller bearings at the positions of higher radial load while allowing the ball bearings to support the thrust loads in combination with the lower radial loads on both shafts.

For a given shaft angle, reduction ratio, size, input torque, and input speed, the design objective is to maximize the life of this reduction as measured by the anticipated mean time between service overhauls (ref. 16). Expected overhauls are based on predictions of pitting fatigue failures in the bearings and gears for steady loads and good lubrication. Under these conditions, a two-parameter Weibull reliability model predicts the service life of the reduction.

### Pitch Cone Angles

At any combination of gear ratio and shaft angle, the pinion and gear pitch cone angles are defined. The gear ratio,  $n$ , has an absolute value greater than one. For a positive gear ratio, the pinion and gears turn in opposite directions as viewed from the backs of the gears. While a negative gear ratio indicates that the pinion and gear rotate in the same direction as viewed from the backs of the gears. The shaft angle,  $\Sigma$ , can have a value between zero and 180 degrees. In terms of these two parameters, the tangent of the pinion cone angle,  $\Gamma_p$ , which is less than 90 degrees, is given by the absolute value:

$$\tan \Gamma_p = \left| \frac{\sin \Sigma}{\cos \Sigma + n} \right| \quad (1)$$

And the tangent of the gear cone angle,  $\Gamma_g$ , which may have a value between zero and 180 degrees, is given by:

$$\tan \Gamma_g = \left| \frac{\sin \Sigma}{\cos \Sigma + 1/n} \right| \quad (2)$$

If the gear cone angle,  $\Gamma_g$ , is less than 90 degrees, then the gear is an external gear as the pinion is. If this angle is equal to 90 degrees, the gear becomes a crown gear with all its teeth in a single plane perpendicular to the axis of the gear. When the gear pitch cone angle is greater than 90 degrees, the gear becomes an internal gear, with its teeth on the inside of the pitch cone.

### Gear Tooth Geometry

The addenda and dedenda of the pinion and gear teeth follow standard bevel tooth proportions (ref. 17). In terms of the back-cone diametral pitch,  $P_d$ , and the gear ratio,  $n$ , these tooth heights are:

$$a_g = \frac{0.46}{P_d} + \frac{0.39}{P_d \cdot n^2} \quad (3)$$

$$a_p = \frac{1.7}{P_d} - a_g \quad (4)$$

$$d_g = \frac{1.888}{P_d} - a_g \quad (5)$$

and

$$d_p = \frac{1.888}{P_d} - a_p \quad (6)$$

The cutter radius,  $R_c$ , is calculated as a polynomial fit to the suggested proportions for spiral bevel manufacture (ref. 12). To match this cutter radius, the maximum face width is limited to be equal to or less than 30 percent of the back-cone distance.

With these proportions, the contact ratio of the spiral bevel gear mesh has two orthogonal components: a face advance contact ratio and the radial contact ratio of the equivalent back-cone spur gears. The total contact ratio is the square root of the sum of the squares of these two contact ratios. Figure 2 shows the face advance contact ratio, which is the ratio of the spiral advance of the gear tooth at the back-cone radius,  $A_o$ , to the circular pitch of the gear teeth at the back-cone radius. In this work, this ratio is limited to be greater than 1.3 to provide some spiral engagement of the gear teeth.

Kinematic interference is modeled with the kinematic interference model of the equivalent back-cone spur gears. For the addendum and dedendum proportions of the standard, this does not appear as an active constraint in the design searches. All potential designs have adequate involute contact. One possible extension of this work is to improve the kinematic interference model and make the addendum and dedendum ratios independent parameters in the design problem. For this work, these ratios are held to the standard values of equations (3) to (6).

### Gear Strength

Tooth loading can cause bending, pitting, and scoring failures in bevel gear teeth as well as in spur gear teeth. A major difference in loading between the two gear types is that the load on a spiral gear tooth is a point load which travels across the tooth, instead of a line load carried by the full width of the tooth as for a spur gear. Standard geometry factors for the bending strength of spiral bevel gear teeth are available in chart form for a 90 degree shaft angle and two or three pressure angles (ref. 18). To permit the optimization to deviate from these conditions, the gear tooth width is taken as the width of the contact ellipse and the spur gear geometry factor is used along with a dynamic load velocity factor.

$$\sigma_b = \frac{K_v F_t P_d}{f_a J} \quad (7)$$

For the examples in this work, the velocity factor increases the load about three fold. A low stress limit of 25 000 psi is used to provide a high design factor for bending strengths.

The contact ellipse size and location and the maximum contact pressure are modeled using a three-dimensional Hertzian contact stress analysis (ref. 19). The cutter radius and the tooth involute curvatures are used to determine the principal curvatures. For most of the examples, the contact ellipse covers about one-third the width of the tooth and the localized maximum Hertzian contact pressure is significantly higher than the two-dimensional equivalent spur gear contact stress calculation. The higher



contact ellipse pressure is used in the gear tooth life model and the scoring failure limit calculation of pressure times sliding velocity.

### Reduction Life

Both bearings and gears are modeled with a linearly decreasing log-strength with log-life relationship. Dynamic capacities,  $C$ , at a life of one-million cycles are used to determine the 90 percent reliability lives,  $t_{10}$ , of the components. The basic relationship is:

$$t_{10} = \left( \frac{C}{F} \right)^p \quad (8)$$

For gears, the dynamic capacity value,  $C$ , is a function of the gear material strength and tooth geometry (refs. 14 and 15). Since the natural log of life is inversely proportional to the contact stress, the load-life factor of 8.93 (ref. 10) for spur gear teeth which see two-dimensional Hertzian contact stress is corrected to 6.0 for the spiral bevel teeth which see three-dimensional Hertzian contact stress. Bearing lives have a similar load-life relationship (refs. 20 and 21) in which the load life factor is lower due to the higher contact stress. The bearing load-life relationship is often modified with life and load adjustment factors. The life adjustment factors are for lubrication and speed effects, while the load adjustment factor converts the applied load to an equivalent radial load.

Describing both gear and bearing life scatter with two-parameter Weibull distributions enables the statistical combination of these lives into a system life at the same 90 percent reliability level (ref. 16). The gamma function converts the 90 percent reliability life into a mean life for the reduction:

$$t_{av} = \frac{t_{10} \Gamma(1 + 1/b)}{[\text{Ln}(1/0.9)]^{1/b}}$$

In these calculations, the Weibull slope,  $b$ , differs for the bearings, gears, and system. The mean life of the reduction is an estimate of the mean time between overhauls for the units in service or the mean service life.

### Interferences

In combining the components into a system, one needs to be concerned with the spatial compatibility of the components. As a design develops, shaft configurations and mounting details enable improved combinations of the components. However, only basic interactions of the components are considered in this study. So each gear and its two support bearings are constrained to have the same shaft diameter. This forces the bore of the bearings to be less than the gear diameter at the root of the bevel teeth on the inside edge of the gear. The geometry also forces the near bearing to be placed behind the gear by a clearance proportional to the widths of the bearing and the gear.

An additional spatial limit in the study is that between the outside diameters of the near bearings on the two shafts. For small shaft angles, the inside corners of the bearing outside diameters must be separated by a sufficient clearance to allow proper mounting.

## Optimization Method

The modified feasible direction gradient search technique uses several vectors. These vectors are the independent design variables,  $X$ ; the inequality constraints,  $V$ ; the parameters of the merit function,  $P$ ; and the constants which define the specific problem,  $C_0$ . An optimization solution is the design variable values,  $X$ , which minimize or maximize the merit function value while maintaining all constraint values,  $V$ , inside their specified limits. A procedure starts with a guess for the design variable,  $X$ , and iterates to find the optimal design.

To maintain balance among the independent design parameters, the design space is scaled into a continuous, dimensionless design space. The scaled design parameters,  $Y$ , vary from  $-1.0$  to  $+1.0$  as specified by upper and lower bounds on the independent design parameters,  $X$ . By setting the upper and lower bounds on the design parameters, the user has control over the relative sensitivity of the design variables in the optimization search. Increasing the range between limits for a variable increases the sensitivity of that variable in the search.

### Gradients

For minimization, the direction of change in  $Y$  which reduces the merit function,  $M$ , at the greatest rate is determined by the unit vector,  $\nabla_m$ :

$$\nabla_m = - \frac{\nabla M}{|\nabla M|} \quad (10)$$

For maximization, the sign in equation (10) reverses.

In the simple gradient search which occurs free of the design constraints, equation (10) defines the direction for the step change in the scaled design vector.

$$Y_{j+1} = Y_j + \Delta S \nabla_m \quad (11)$$

where  $\Delta S$  is the scalar magnitude of the step. If no constraints are violated, this will be the next value for  $Y$  in the search.

A unit gradient in a constraint variable is defined as:

$$\nabla_{v_k} = - \frac{\nabla V_k}{|\nabla V_k|} \quad (12)$$

where  $\nabla_{v_k}$  is a unit vector in the direction of decreasing value in the constraint,  $V_k$ . For upper bound constraints, moving through the design space in the direction of  $\nabla_{v_k}$  reduces the constraint value  $V_k$ . For lower bound constraints, a sign reversal in equation (12) produces an increase in the constraint value,  $V_k$ , for motion in the gradient direction. The vector sum of the gradients in the violated constraints,  $\nabla_h$ , is the second gradient of the feasible direction algorithm:

$$\nabla h = \frac{\sum_k \nabla v_k}{\left| \sum_k \nabla v_k \right|} \quad (13)$$

The gradient in the violated constraints,  $\nabla h$ , points towards the acceptable design space from the unacceptable design space. By itself, it enables the algorithm to turn an unacceptable initial guess into an acceptable trial design by a succession of steps:

$$Y_{j+1} = Y_j + \Delta S \nabla h \quad (14)$$

Once inside the acceptable design region, the algorithm proceeds along the steepest descent direction until the calculated step places the next trial outside the acceptable design space. To avoid this condition, the algorithm selects a feasible direction for the next step. Figure 3 shows a constraint limit intersecting contour lines of improving merit function values. The figure shows gradients in the merit function,  $\nabla m$ , and the impending constraint,  $\nabla h$ . The feasible direction selected,  $\nabla f$ , is the unit vector sum of these two gradients:

$$\nabla f = \frac{\nabla m + \nabla h}{|\nabla m + \nabla h|} \quad (15)$$

And the next design step becomes:

$$Y_{j+1} = Y_j + \nabla S \Delta f \quad (16)$$

### Solution

The step size,  $\Delta S$ , is a significant element of any optimization procedure (ref. 13). For stability and directness, the step size of this work normally is fixed. Initially, the step size is 5 percent of the range of a single design parameter. But the procedure halves the step whenever a local minimum is reached or the search is trapped in a constraint corner.

To end the design search, the procedure declares a solution when the percent change in the merit function,  $M$ , is less than a pre-set limit.

$$\left| \frac{M_{j+1} - M_j}{M_j} \right| < e_t \quad (17)$$

If this limit is not reached, a pre-set limit of optimization steps signals the end of the design search.

## Computer Program

The spiral bevel design problem is incorporated in the program as a series of design analysis sub-routines which evaluate the design constraint and merit function values for each design parameter vector. User interfaces to the optimizing routines include: an input file, an output file, terminal graphic output, and terminal text output and input.

The program provides user control over its operation through the input file and through terminal interaction. The input file allows the designer to set: the design constants, active constraints, the initial design parameter values, and design parameter ranges for the design search. The design parameter ranges influence the relative sensitivities of the different design parameters in the search. By increasing the range between the low and high limits on a design variable, the designer makes that variable more active in the design search. The program does overcome poor initial design values and should find the same optimum with different parameter sensitivities, but adjustments in these values give the designer control in the optimization process.

In the terminal interaction phase, the program summarizes the optimal design and its constraint values and offers the designer the opportunity to modify the design for a comparison analysis. If this option is chosen, the modified design is analyzed and a full report of its properties is placed on the screen and in the output file. The opportunity to modify the last design continues until the designer chooses to end the program.

The program includes a graphic output routine which generates a scaled schematic view of the transmission similar to the drawing in figure 1. This view is of the plane of the input and output shafts. In the view, the basic components - gears, bearings and shaft proportions appear in scale without the dimensions of figure 1. The drawing improves design awareness in this early stage of transmission evaluation.

## Transmission Design

Consider the design of gear reductions to transmit an input torque of 600 lb-in. at 1000 rpm at a power level of 9.5 hp with a ratio of 2:1. The back-cone distance of the designs is fixed at 5 in. as is the shaft lengths from the center of the gear to the center of the rear ball bearing. A series of designs is sought with shaft angles that vary from 60 degrees to 120 degrees. Extra-light 100 series bearings are used throughout.

Six independent design parameters are sought for each design:

1. the mesh face width,  $f$ ;
2. the number of pinion teeth,  $N_p$ ;
3. the normal pressure angle,  $\phi$ ;
4. the mesh spiral angle,  $\psi$ ;
5. the pinion shaft diameter,  $D_p$ ; and
6. the gear shaft diameter,  $D_g$ .

The optimal design criterion is the maximum mean service life between overhauls for the reductions.

Among the design constraints active in the program are the:

1. tooth bending stress,
2. tooth contact pressure,
3. tooth pressure times sliding velocity,
4. face contact ratio, and
5. back-cone contact ratio.

The design constraints include radial clearances between the bearings and gears which key the interaction between these components in the designs. The inside bores of the bearings are held to be smaller than the inside rim of the supported gear at its small end. Several other factors such as: contact ellipse shift, shaft stress, back-cone involute interference, cutter radius, dynamic load, and roller bearing location are included in the constraint list but are not listed for brevity's sake.

Table I lists the initial guess and optimal design values for the cases with shaft angles of 80 and 100 degrees. Table II lists the values of the merit function, the five cited constraints and the pinion cone angle and pitch diameter for these designs. Figure 4 is a schematic of the 80 degree design and figure 5 shows the 100 degree shaft angle design. Both designs have a diametral pitch near 10. The two designs have nearly the same weight but significantly different service lives of 5870 hr for the 80 degree shaft angle design and 18 260 hr for the 100 degree shaft angle design. The service life difference is attributable to the increase in pinion size with the increase in shaft angle. The larger pinion has lower contact and bearing forces for the same transmitted torque as well as larger and stronger bearings. In all the designs, the weakest component from a life standpoint is the rear ball bearing on the pinion shaft.

As the shaft angle increases from 60 to 120 degrees, the optimum design life increases as shown in figure 6 with the maximum rate of increase occurring at a shaft angle of 90 degrees. Lower rates of increase in life occur at low and high shaft angles. The larger gear increased in cone angle from 40.893 degrees for the 60 degree shaft angle to 90 degrees for the 120 degree shaft angle. A cone angle of 90 degrees makes the output gear a crown gear.

In the optimal designs, the gear face widths are less than the 30 percent back-cone distance limit of 1.5 in. and the number of pinion teeth is larger than expected. These results are due to interactions of the pinion shaft bearing life requirements with the face contact ratio and pinion bore to gear internal diameter clearance limits. The face contact ratio increases with increasing pitch for the same back-cone distance, face width, and spiral angle. The bearing capacity increases with its bore which also increases with a decreasing gear face width for a fixed back-cone distance and cone angle.

For these designs, the number of teeth on the pinion rose from 29 for a shaft angle of 60 degrees to 45 for a shaft angle of 120 degrees. The pinion pitch diameter increased from 3.27 in. for a shaft angle of 60 degrees to 5.0 in. for a shaft angle of 120 degrees. The pressure angle stayed nearly constant at 22 degrees and the spiral angle dropped from 30 degrees for shaft angles below 90 degrees to about 25 degrees for shaft angles of 90 degrees and above.

## SUMMARY AND CONCLUSIONS

A modified feasible directions gradient search optimization procedure has been applied to the problem of designing a spiral bevel gear reduction with a fixed back-cone distance for a maximum life between service overhauls. The gear and pinion shaft lengths are equal to the back-cone distance and each shaft is supported in a ball and roller bearing with the roller bearing close to the gear and both bearings behind

the gear. The spiral bevel gear transmits a selected power at a selected input speed to a given output speed through a specified shaft angle.

The procedure finds six independent design parameter values: the mesh face width, the number of pinion teeth, the pressure angle, the spiral angle, and the pinion and gear shaft diameters. The diametral pitch of the gears is a function of these parameters.

The optimization is performed by a program with user interfaces which allow control over the input parameters and enable the designer to check other designs with the program's analysis routines. Thus practical, near optimal designs may be found with the program.

Examples at various shaft angles demonstrate a dramatic increase in service life with an increase in shaft angle. The service lives of the designed reductions are influenced strongly by the lives of the pinion shaft ball bearings, since the pinion shaft thrust load is a major load in these reductions.

In the optimal designs, the gear face widths are lower than the maximum allowed and the numbers of pinion teeth are greater than the minimum allowed. The optimal pressure angles are close to 22 degrees for most designs and the spiral angles range from 30 to 25 degrees as the shaft angle increases.

#### REFERENCES

1. Dudley, D.W.: The Evolution of The Gear Art, American Gear Manufacturers Association, 1969.
2. Coleman, W.: Guide to Bevel Gears, Product Engineering, 1963, pp. 87-95.
3. M.L. Baxter, Jr.: Exact Determination of Tooth Surfaces for Spiral Bevel and Hypoid Gears, AGMA Paper 139.02, Oct. 1966.
4. Krenzer, T.J.: Tooth Contact Analysis of Spiral Bevel and Hypoid Gears Under Load, SAE Paper 810688, Apr. 1981.
5. P. Fort: Computer Aided Design, Manufacturing and Inspection System for Spiral Bevel Gears, ASME Paper 80-C2/DET-127, Aug. 1980.
6. Litvin, F.L.: Theory of Gearing, NASA RP-1212, Dec. 1989.
7. Litvin, F.L., Zhang Y., and Handschuh, R.F.: Local Synthesis and Tooth Contact Analysis of Face Milled Spiral Bevel Gears, Proceedings of the International Conference on Motion and Power Transmissions, Hiroshima, Japan, pp. 721-724, Nov. 1991.
8. Gosselin, C., Cloutier L., and Brousseau, J.: Tooth Contact Analysis of High Conformity Spiral Bevel Gears, Proceedings of the International Conference on Motion and Power Transmissions, Hiroshima, Japan, pp. 725-730, Nov. 1991.
9. Standard for Spur, Helical, Herringbone and Bevel Enclosed Drives, AGMA 6010-E88, AGMA Standard, Arlington, VA, Nov. 1988.
10. Drago, R.J.: Fundamentals of Gear Design, Butterworth, 1988.

11. Dudley, D.W.: Handbook of Practical Gear Design, McGraw Hill, 1984.
12. Hotchkiss, R.G., McVea, W.R., and Kitchen, R.L.: Bevel and Hypoid Gear Manufacturing, Dudley's Gear Handbook, D.P. Townsend, ed., McGraw Hill, 2nd Edition, 1991.
13. Numerical Optimization Techniques for Engineering Design: With Applications, G.N. Vanderplaats, McGraw Hill, 1984.
14. Savage, M., Coy, J.J., and Townsend, D.P.: Optimal Tooth Numbers for Compact Standard Spur Gear Sets, ASME Journal of Mechanical Design, Vol. 104, No. 4, pp. 749-758, Oct. 1982.
15. Savage, M., Mackulin, B., Coe H., and Coy, J.J.: Maximum Life Spur Gear Design, NASA TM-104361, June 1991.
16. Savage, M., Radil, K.C., Lewicki, D.G., and Coy, J.J.: Computerized Life and Reliability Modeling for Turboprop Transmissions, AIAA Journal of Propulsion and Power, Vol. 5, No. 5, pp. 610-614, Sept.- Oct. 1989.
17. Dean, P.M.: Gear Tooth Proportions, Gear Handbook, D.W. Dudley, ed., McGraw Hill, 1962.
18. Geometry Factors for Determining the Strength of Spur, Helical, Herringbone and Bevel Gear Teeth, AGMA 226.01, AGMA Standard, Arlington, VA, Aug. 1970.
19. Savage, M., Altidis, P.C., Lewicki, D.G., Coy, J.J., and Litvin, F.L.: Tooth Contact Shift in Loaded Spiral Bevel Gears, Savage, ASME Proceedings of the 1989 International Power Transmission and Gearing Conference, Chicago, IL., pp. 203-212, Apr. 1989.
20. Zaretsky, E.V., et al.: Life Adjustment Factors for Ball and Roller Bearings, ASME Engineering Design Guide, ASME, New York, 1971.
21. Harris, T.A.: Rolling Bearing Analysis, Wiley, 2nd Edition, 1984.

TABLE I.—DESIGN PARAMETER VALUES

	Initial	Shaft angle	
		80 degree	100 degree
Face width, in.	2.0	1.0	1.1
Pinion teeth	20	37	43
Pressure angel, deg	20.0	22.0	22.0
Sprial angle, deg	35.0	30.0	25.0
Pinion shaft diameter, mm	50.0	70.0	80.0
Gear shaft diameter, mm	60.0	75.0	80.0

TABLE II.—PROPERTY VALUES

	Shaft angle	
	80 degree	100 degree
Service life, hr	5870	18 260
Bending stress, ksi	19	18.9
Contact pressure, ksi	396	312
Pressure x velocity, 10 <sup>6</sup> psi-ft/min	3.4	2.5
Face contact ratio	1.3	1.46
Radial contact ratio	1.34	1.48
Pinion cone angle, deg	24.37	28.33
Pinion pitch diameter, in.	4.13	4.75

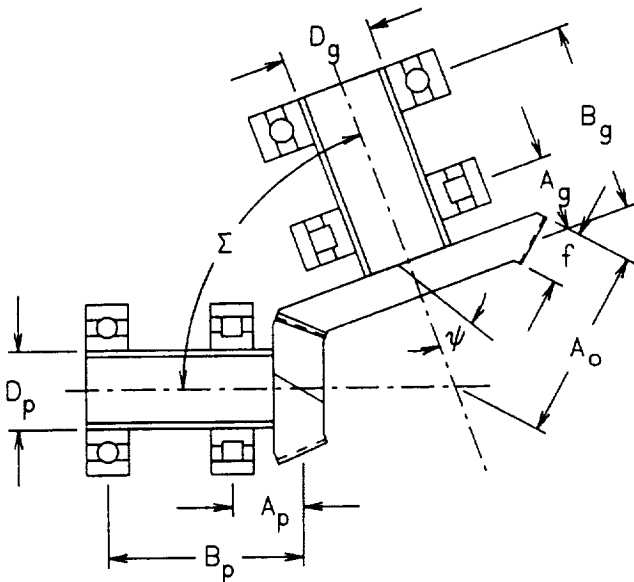

Figure 1.—Spiral bevel reduction parameters.

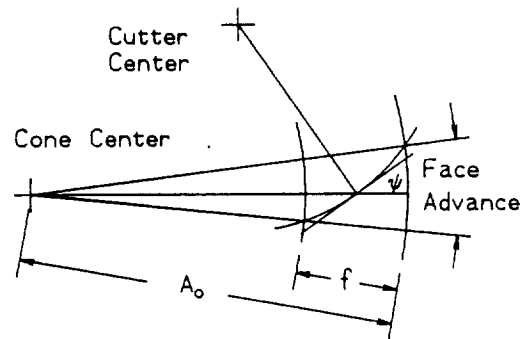

Figure 2.—Face contact ratio geometry.

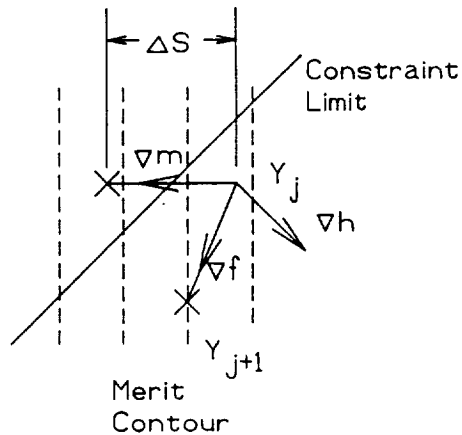

Figure 3.—Feasible direction gradient vector.

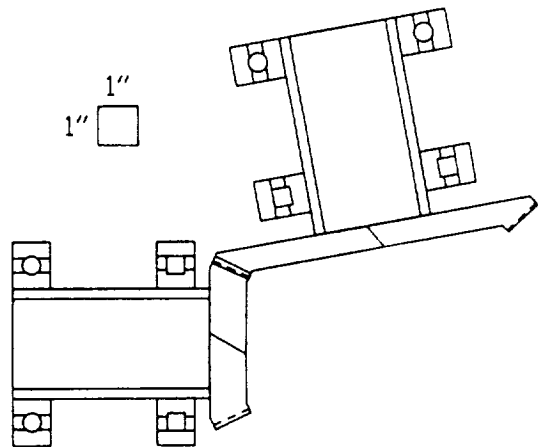

Figure 4.—Eighty degree shaft angle design with a life of 5870 hr.



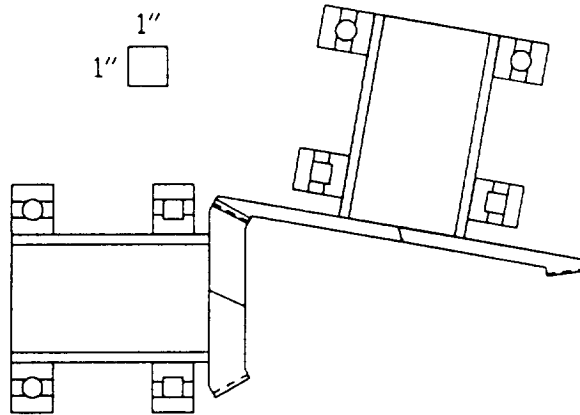

Figure 5.—One-hundred degree shaft angle design with a life of 18 260 hr.

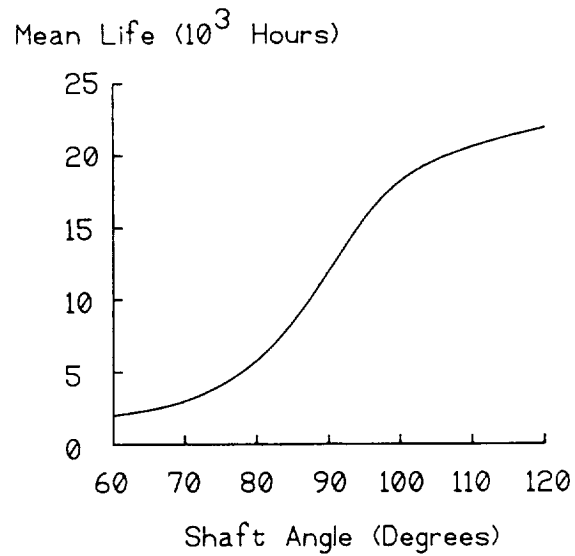

Figure 6.—Reduction mean service life versus shaft angle for optimal designs.

REPORT DOCUMENTATION PAGE			Form Approved OMB No. 0704-0188	
Public reporting burden for this collection of information is estimated to average 1 hour per response, including the time for reviewing instructions, searching existing data sources, gathering and maintaining the data needed, and completing and reviewing the collection of information. Send comments regarding this burden estimate or any other aspect of this collection of information, including suggestions for reducing this burden, to Washington Headquarters Services, Directorate for Information Operations and Reports, 1215 Jefferson Davis Highway, Suite 1204, Arlington, VA 22202-4302, and to the Office of Management and Budget, Paperwork Reduction Project (0704-0188), Washington, DC 20503.				
1. AGENCY USE ONLY (Leave blank)	2. REPORT DATE July 1992	3. REPORT TYPE AND DATES COVERED Technical Memorandum		
4. TITLE AND SUBTITLE Maximum Life Spiral Bevel Reduction Design			5. FUNDING NUMBERS  WU-505-63-36 1L162211A47A	
6. AUTHOR(S) M. Savage, M.G. Prasanna, and H.H. Coe				
7. PERFORMING ORGANIZATION NAME(S) AND ADDRESS(ES)  National Aeronautics and Space Administration Lewis Research Center Cleveland, Ohio 44135-3191			8. PERFORMING ORGANIZATION REPORT NUMBER  E-7220	
9. SPONSORING/MONITORING AGENCY NAMES(S) AND ADDRESS(ES)  National Aeronautics and Space Administration Washington, D.C. 20546-0001			10. SPONSORING/MONITORING AGENCY REPORT NUMBER  NASA TM-105790 AVSCOM TR-92-C-004	
11. SUPPLEMENTARY NOTES Prepared for the 28th Joint Propulsion Conference and Exhibit cosponsored by the AIAA, SAE, ASME, and ASEE. Huntsville, Tennessee, July 6-8, 1992. M. Savage and M.G. Prasanna, University of Akron, Akron, Ohio 44325. H.H. Coe, NASA Lewis Research Center, Cleveland, Ohio. Responsible person, H.H. Coe, (216) 433-3971.				
12a. DISTRIBUTION/AVAILABILITY STATEMENT  Unclassified - Unlimited Subject Category 37			12b. DISTRIBUTION CODE	
13. ABSTRACT (Maximum 200 words) Optimization is applied to the design of a spiral bevel gear reduction for maximum life at a given size. A modified feasible directions search algorithm permits a wide variety of inequality constraints and exact design requirements to be met with low sensitivity to initial values. Gear tooth bending strength and minimum contact ratio under load are included in the active constraints. The optimal design of the spiral bevel gear reduction includes the selection of bearing and shaft proportions in addition to gear mesh parameters. System life is maximized subject to a fixed back-cone distance of the spiral bevel gear set for a specified speed ratio, shaft angle, input torque and power. Significant parameters in the design are: the spiral angle, the pressure angle, the numbers of teeth on the pinion and gear and the location and size of the four support bearings. Interpolated polynomials expand the discrete bearing properties and proportions into continuous variables for gradient optimization. After finding the continuous optimum, a designer can analyze near optimal designs for comparison and selection. Design examples show the influence of the bearing lives on the gear parameters in the optimal configurations. For a fixed back-cone distance, optimal designs with larger shaft angles have larger service lives.				
14. SUBJECT TERMS Optimization; Computer program; Gears; Design			15. NUMBER OF PAGES 16	
			16. PRICE CODE A03	
17. SECURITY CLASSIFICATION OF REPORT Unclassified	18. SECURITY CLASSIFICATION OF THIS PAGE Unclassified	19. SECURITY CLASSIFICATION OF ABSTRACT Unclassified	20. LIMITATION OF ABSTRACT	

National Aeronautics and  
Space Administration

Lewis Research Center  
Cleveland, Ohio 44135

Official Business  
Penalty for Private Use \$300

**FOURTH CLASS MAIL**

ADDRESS CORRECTION REQUESTED



Postage and Fees Paid  
National Aeronautics and  
Space Administration  
NASA 451

**NASA**

---

