

Maximum Power Point Tracking using Fuzzy Logic Control for Photovoltaic Systems

Pongsakor Takun, Somyot Kaitwanidvilai and Chaiyan Jettanasen

Abstract—In this paper, a fuzzy logic control (FLC) is proposed to control the maximum power point tracking (MPPT) for a photovoltaic (PV) system. The proposed technique uses the fuzzy logic control to specify the size of incremental current in the current command of MPPT. As results indicated, the convergence time of maximum power point (MPP) of the proposed algorithm is better than that of the conventional Perturb and Observation (P&O) technique.

Index Terms—photovoltaic system, MPPT, P&O, Fuzzy Logic Control

I. INTRODUCTION

IN our world today, the problems caused by global warming and pollution effect become the important issues for research. Renewable energy sources are considered as a technological option for generating clean energy. Among them, photovoltaic (PV) system has received a great attention as it appears to be one of the most promising renewable energy sources. Recently, due to its development and cost reduction, PV system becomes an efficient solution to the environmental problem [1]. However, the development for improving the efficiency of the PV system is still a challenging field of research.

PV system cannot be modeled as a constant DC current source because its output power is varied depending on the load current, temperature and irradiation.

Generally, MPPT is adopted to track the maximum power point in the PV system. The efficiency of MPPT depends on both the MPPT control algorithm and the MPPT circuit. The MPPT control algorithm is usually applied in the DC-DC converter, which is normally used as the MPPT circuit. Typical diagram of the connection of MPPT in a PV system is shown in Fig. 1.

One of the most popular algorithms of MPPT is P&O (Perturb and Observe) technique; however, the convergence problem and oscillation are occurred at certain points during the tracking. To enhance the performance of the P&O algorithm, this paper presents the application of Fuzzy Logic Control (FLC) to the MPPT control. The simulation study in this paper is done in MATLAB and Simulink.

Manuscript received January 25, 2011. This work was supported by the faculty of engineering, King Mongkut's Institute of Technology Ladkrabang, Thailand.

P. Takun, S. Kaitwanidvilai and C. Jettanasen are with the Faculty of Engineering, King Mongkut's Institute of Technology Ladkrabang, Bangkok 10520, Thailand (e-mail: uk_dtoth_cz@hotmail.com, drsomyotk@gmail.com).

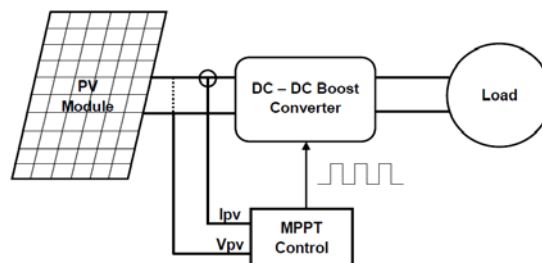

Fig. 1 Typical diagram of MPPT in a PV System

II. PHOTOVOLTAIC EQUIVALENT CIRCUIT

The model of solar cell can be categorized as p-n semiconductor junction; when exposed to light, the DC current is generated. As known by many researchers, the generated current depends on solar irradiance, temperature, and load current. The typical equivalent circuit of PV cell is shown in Fig. 2.

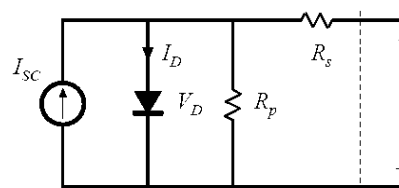

Fig. 2 Typical circuit of PV solar cell

The basic equations describing the I-V characteristic of the PV model are given in the following equations:

$$0 = I_{SC} - I_D - \frac{V_D}{R_p} - I_{PV} \quad (1)$$

$$I_D = I_0 (e^{V_D/V_T} - 1) \quad (2)$$

$$V_{PV} = V_D - R_s I_{PV} \quad (3)$$

Where:

I_{PV} is the cell current (A).

I_{SC} is the light generated current (A).

I_D is the diode saturation current (A).

R_s is the cell series resistance (ohms).

R_p is the cell shunt resistance (ohms).

V_D is the diode voltage (V).

V_T is the temperature voltage (V).

V_{PV} is the cell voltage (V).

III. MAXIMUM POWER POINT TRACKING TECHNIQUES

A. Perturb and Observation (P&O)

One of the most simple and popular techniques of MPPT is the P&O technique. The main concept of this method is to push the system to operate at the direction which the output power obtained from the PV system increases. Following equation describes the change of power which defines the strategy of the P&O technique.

$$\Delta P = P_k - P_{k-1} \tag{4}$$

If the change of power defined by (4) is positive, the system will keep the direction of the incremental current (increase or decrease the PV current) as the same direction, and if the change is negative, the system will change the direction of incremental current command to the opposite direction. This method works well in the steady state condition (the radiation and temperature conditions change slowly). However, the P&O method fails to track MPP when the atmospheric condition is rapidly changed. Flow chart of the P&O method is described in Fig. 3.

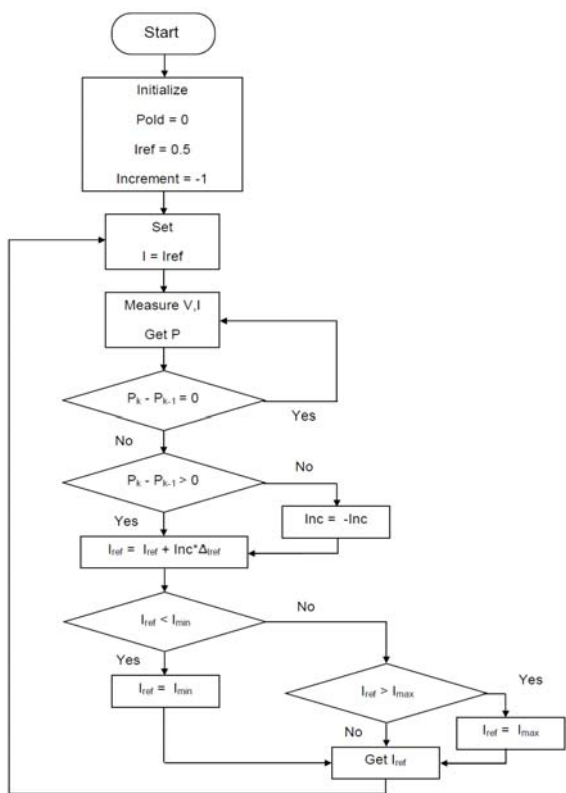

Fig. 3 Flow Chart of the P&O Method.

B. MPPT using Fuzzy Logic Control

MPPT using Fuzzy Logic Control gains several advantages of better performance, robust and simple design. In addition, this technique does not require the knowledge of the exact model of system. The main parts of FLC, fuzzification, rule-base, inference and defuzzification, are shown in Fig. 4. In the proposed system, the input variables of the FLC are the change in PV array power (ΔP_{pv}) and the change in PV current (ΔI_{pv}), whereas the output of FLC is the magnitude of the change of boost converter current

reference (ΔI_{ref}). The current reference is the command for controlling the current drawn from the PV. Flow chart of the proposed FLC is shown in Fig. 5. The equations for ΔP_{pv} and ΔI_{pv} are given as follows:

$$P_{pv}^k = V_{pv}^k \cdot I_{pv}^k \tag{5}$$

$$\Delta P_{pv}^k = P_{pv}^k - P_{pv}^{k-1} \tag{6}$$

$$\Delta I_{pv}^k = I_{pv}^k - I_{pv}^{k-1} \tag{7}$$

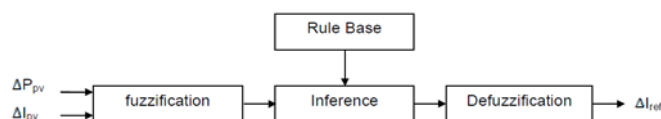

Fig. 4 The Fuzzy Logic Controller

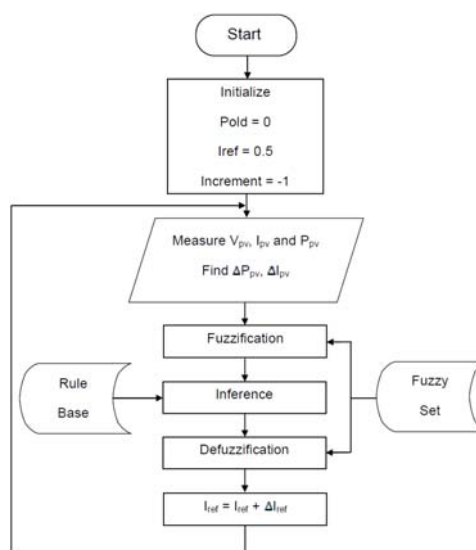

Fig. 5 Flowchart of the proposed FLC method

In the proposed design, the universe of discourse for the first input variable (ΔP_{pv}) is assigned in terms of several linguistic variables by using seven fuzzy subsets, which are denoted by NB (negative big), NM (negative medium), NS (negative small), Z (zero), PS (positive small), PM (positive medium) and PB (positive big). The membership functions for the variable are shown in Fig. 6. Fig. 7 shows the universe of discourse for the second input variable (ΔI_{pv}), which is classified into 3 fuzzy sets, namely, Negative (N), Zero (Z) and Positive (P). Fig.8 shows the control surface of the output variable, ΔI_{ref} .

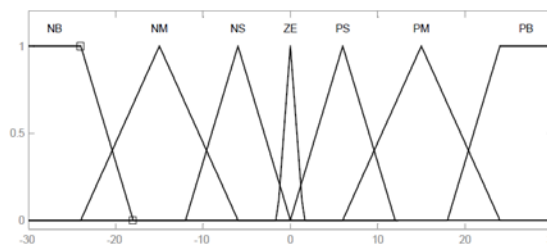

Fig. 6 Membership Functions of the 1st Input Variable 1st (ΔP_{pv})

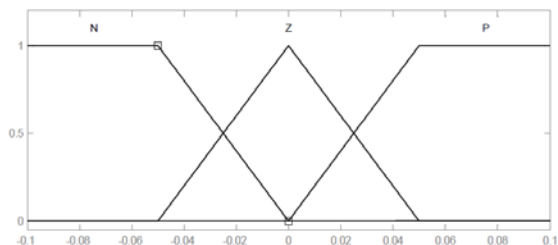

Fig. 7 Membership Functions of the 2nd Input Variable 2nd (ΔI_{pv})

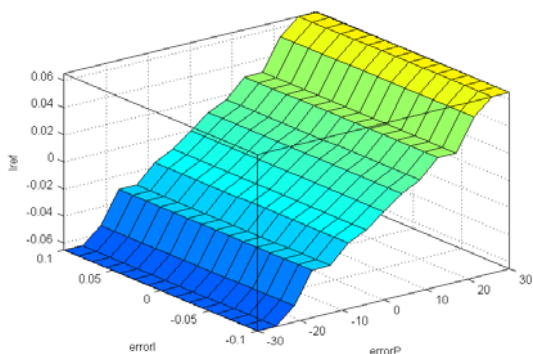

Fig. 8 Sugeno Control Surface, Output Variable (ΔI_{ref})

Based on the knowledge of the authors, the fuzzy system rules can be designed as shown in Table 1. ΔP_{pv} and ΔI_{pv} are the inputs while ΔI_{ref} is the output. The fuzzy inference of the proposed FLC is based on the Sugeno's method which is associated with the max-min composition.

Table 1: Rules for the proposed FLC

Rule no.	If ΔP_{pv}	And ΔI_{pv}	Then ΔI_{ref}	Singletons
1	PB	P	PB	0.065
2	PM	P	PM	0.03
3	PS	P	PS	0.01
4	ZE	P	PS	0.01
5	NS	P	NS	-0.01
6	NM	P	NM	-0.03
7	NB	P	NB	-0.065
8	PB	Z	PB	0.065
9	PM	Z	PM	0.03
10	PS	Z	PS	0.01
11	ZE	Z	ZE	0
12	NS	Z	NS	-0.01
13	NM	Z	NM	-0.03
14	NB	Z	NB	-0.065
15	PB	N	NB	-0.065
16	PM	N	NM	-0.03
17	PS	N	NS	-0.01
18	ZE	N	NS	-0.01
19	NS	N	PS	0.01
20	NM	N	PM	0.03
21	NB	N	PB	0.065

IV. MODEL OF THE SYSTEM

The proposed Fuzzy Logic Control based MPPT has been modeled and simulated using MATLAB/Simulink. Fig. 9 shows our developed Simulink model. In the simulation study, the fuzzy logic based MPPT control is simulated and compared with the conventional P&O technique under the operating condition assuming the constant temperature and varying isolation (0 to 1000 W/m²). The step size of incremental current in the P&O technique uses the appropriate value found by trial and error technique. The MPPT control consists of two main parts, FLC and current

control, as depicted in Fig. 9. The specifications of PV module used in this simulation are shown in Table 2.

Table 2 the specification of PV module used in the simulation.

Short Circuit Current	7.8	A
Open Circuit Voltage	21	V
Current at Pmax	6.72	A
Volt at Pmax	12.7	V

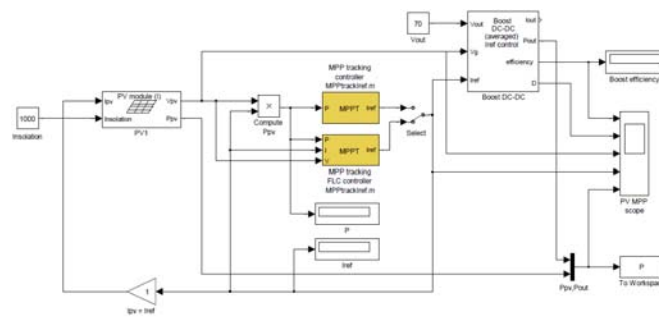

Fig. 9 Model of the developed PV System in MATLAB/Simulink

V. RESULT AND DISCUSSION

Figs. 10 and 11 show the results of the I-V and P-V characteristic curves of the PV module with the varying of irradiation. As seen in these figures, the I-V curves and the maximum points in the P-V curves are changed under the variations of operating condition.

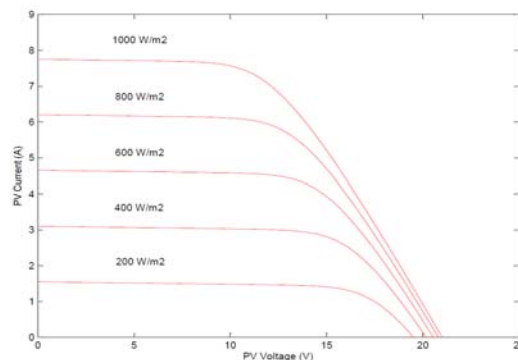

Fig. 10 I-V Characteristic Curves

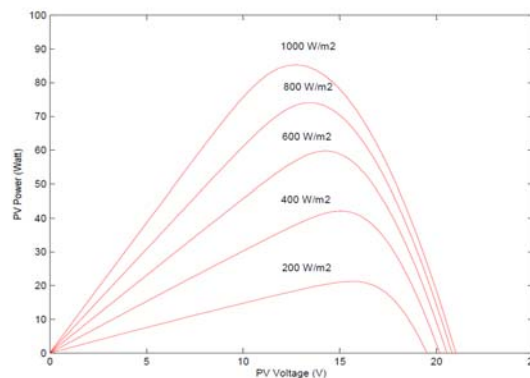

Fig. 11 P-V Characteristic Curves

The performance of MPPT using the FLC and the simple P&O techniques is verified by operating them under the variation of irradiance. Fig. 12 shows the transient responses of the tracking power curves obtained from both control algorithms. As seen in the figure, the proposed response is much faster than that of the conventional MPPT while the overshoots of the system are almost the same. Fig.13 shows the energy obtained from the both controllers; clearly, the proposed controller gains more energy than the conventional P&O technique.

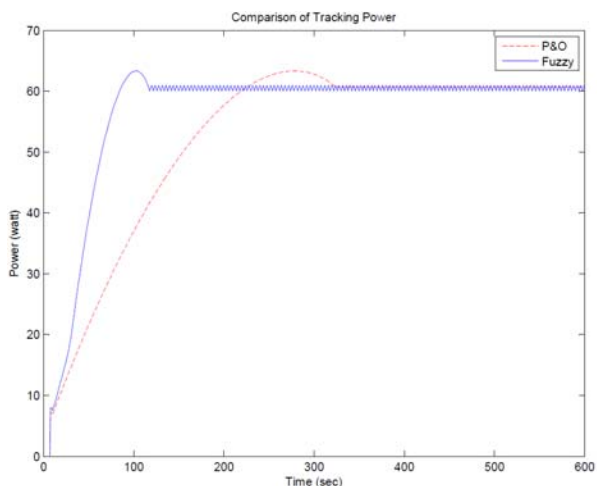

Fig. 12 Tracking curves by the FLC and P&O Methods

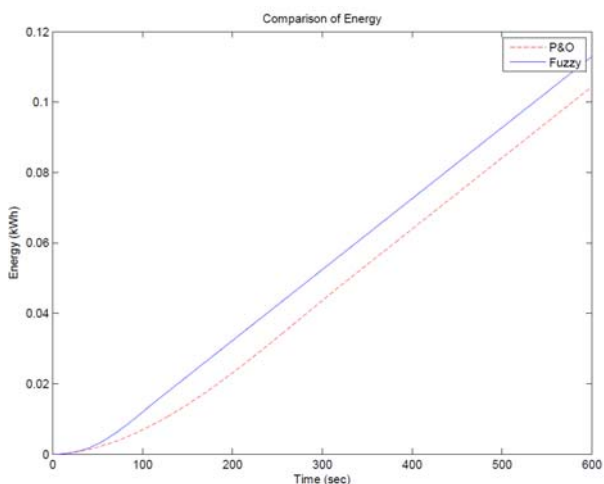

Fig. 13 Energy obtained from the both controllers.

Fig. 14 shows the performance of the PV system using FLC and P&O algorithms under fast changing of irradiance. The irradiance values are 400, 400, 600, 600, 600, 600, 1000, 1000, 600, 600, 600, 600, 200 and 200 W/m² at 0, 60, 120, 180, 240, 300, 360, 420, 480, 540, 600, 660, 720, and 780 seconds, respectively. The MPPT using FLC gives the results better than the P&O in several areas of the tracking curve. Fig. 15 shows the energy gained from the tracking power curve in Fig. 14; clearly, the energy gained from the proposed technique is higher than that of the conventional technique.

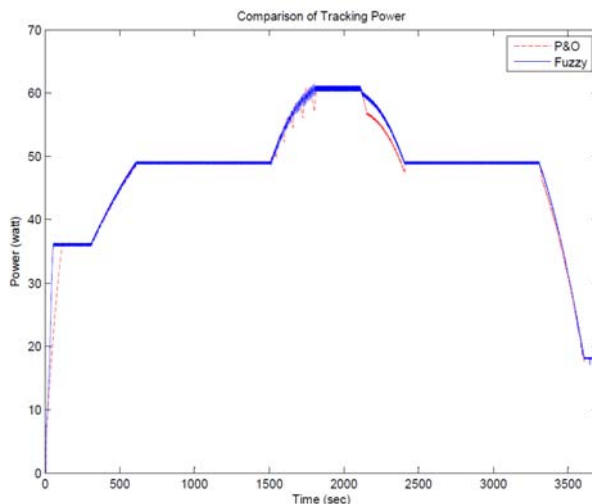

Fig. 14 MPP Tracking curves by the FLC and P&O methods.

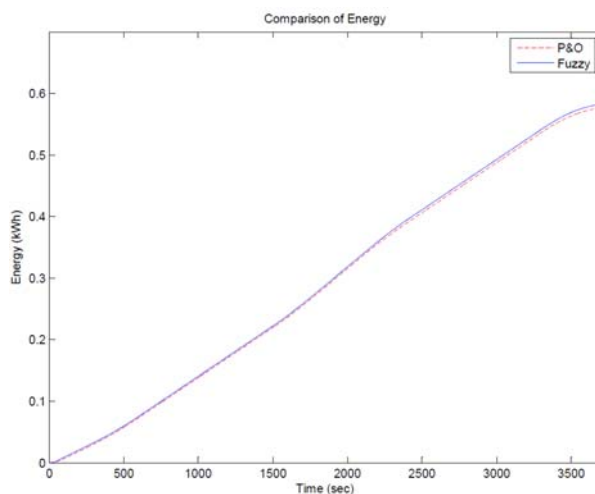

Fig.15 Energy obtained from the MPP tracking curves in Fig. 14.

VI. CONCLUSIONS

This paper presents an intelligent control strategy of MPPT for the PV system using the FLC. Simulation results show that the proposed MPPT can track the MPP faster when compared to the conventional P&O method. In conclusion, the proposed MPPT using fuzzy logic can improve the performance of the system. For the future work, we intend to implement the proposed technique in the real PV system.

ACKNOWLEDGMENT

This research work is supported by the research fund from Faculty of Engineering, King Mongkut's Institute of Technology Ladkrabang, Thailand.

REFERENCES

- [1] Subiyanto, A Mohamed, M A Hannan, "Maximum Power Point Tracking in Grid Connected PV System Using A Novel Fuzzy Logic Controller", *IEEE Student Conference on Research and Development*, November 2009.

- [2] Chokri Ben Salah*, Mohamed Ouali, "Comparison of fuzzy logic and neural network in maximum power point tracker for PV systems", *ScienceDirect Electric Power Systems Research*, July 2010, pp.43–50.
- [3] Mohamed Azab, "A New Maximum Power Point Tracking for Photovoltaic Systems", *World Academy of Science, Engineering and Technology*, Vol. 34, October 2008.
- [4] C. Larbes, S.M. Ar't Cheikh*, T. Obeidi, A. Zerguerras, "Genetic algorithms optimized fuzzy logic control for the maximum power point tracking in photovoltaic system", *ScienceDirect Renewable Energy* 34, January 2009, pp.2093–2100.
- [5] Cheikh M. S. A., Larbes C., Kebir G. F. T. and Zerguerras A., "Maximum power point tracking using a fuzzy logic control scheme", *Revue des Energies Renouvelables*, Vol. 10, No. 32, September 2007, pp. 387 – 395.
- [6] Sofai. Lalouni, Djamila. Rekioua, "Modeling and Simulation of Photovoltaic System using Fuzzy Logic Controller", *IEEE International Conference on Developments in Systems Engineering*, 2009.
- [7] Noppadol Khaehintung, Anantawat Kunakorn, and Phaophak Sirisuk, "A Novel Fuzzy Logic Control Technique tuned by Particle Swarm Optimization for Maximum Power Point Tracking for a Photovoltaic System using a Current-mode Boost Converter with Bifurcation Control", *Springer International Journal of Control, Automation, and Systems*, October 2009, pp.289-300.
- [8] Chen-Chi Chu, Chieh-Li Chen, "Robust maximum power point tracking method for photovoltaic cells : A sliding mode control approach", *ScienceDirect Solar Energy*, March 2009.
- [9] Chao Zhang, Dean Zhao, "MPPT with Asymmetric Fuzzy Control for Photovoltaic System", *IEEE Africon*, 2009.
- [10] Christopher A. Otieno, George N. Nyakoe, Cyrus W. Wekesa, "A Neural Fuzzy Based Maximum Power Point Tracker for a Photovoltaic System", *IEEE Africon*, September 2009.
- [11] Santos J. L., Antunes F., Chehab A. And Cruz C. C., "A maximum power point tracker for PV systems using a high performance boost converter", *Science Direct. Solar Energy* 80, 2006, pp. 772–778.