



Aalborg Universitet

AALBORG UNIVERSITY
DENMARK

Measurements on Buoyant Jet Flows from a Ceiling-Mounted Slot Diffuser

Nielsen, Peter V.; Möller, Åke T. A.

Publication date:
1988

Document Version
Publisher's PDF, also known as Version of record

[Link to publication from Aalborg University](#)

Citation for published version (APA):

Nielsen, P. V., & Möller, Å. T. A. (1988). *Measurements on Buoyant Jet Flows from a Ceiling-Mounted Slot Diffuser*. Dept. of Building Technology and Structural Engineering, Aalborg University. Indoor Environmental Technology Vol. R8832 No. 6

General rights

Copyright and moral rights for the publications made accessible in the public portal are retained by the authors and/or other copyright owners and it is a condition of accessing publications that users recognise and abide by the legal requirements associated with these rights.

- Users may download and print one copy of any publication from the public portal for the purpose of private study or research.
- You may not further distribute the material or use it for any profit-making activity or commercial gain
- You may freely distribute the URL identifying the publication in the public portal -

Take down policy

If you believe that this document breaches copyright please contact us at vbn@aub.aau.dk providing details, and we will remove access to the work immediately and investigate your claim.

INSTITUTTET FOR BYGNINGSTEKNIK
INSTITUTE OF BUILDING TECHNOLOGY AND STRUCTURAL ENGINEERING
AALBORG UNIVERSITETSCENTER · AUC · AALBORG · DANMARK

INDOOR ENVIRONMENTAL TECHNOLOGY
PAPER NO. 6

Presented at the 3rd Seminar on »Application of Fluid Mechanics in Environmental Protection
-88», Silesian Technical University, Gliwice, Poland

PETER V. NIELSEN, ÅKE T. A. MÖLLER
MEASUREMENTS ON BUOYANT JET FLOWS FROM A CEILING-MOUNTED SLOT DIF-
FUSER
NOVEMBER 1988

ISSN 0902-7513 R8832

The papers on INDOOR ENVIRONMENTAL TECHNOLOGY are issued for early dissemination of research results from the Indoor Environmental Technology Group at the University of Aalborg. These papers are generally submitted to scientific meetings, conferences or journals and should therefore not be widely distributed. Whenever possible reference should be given to the final publications (proceedings, journals, etc.) and not to the paper in this series.

INSTITUTTET FOR BYGNINGSTEKNIK
INSTITUTE OF BUILDING TECHNOLOGY AND STRUCTURAL ENGINEERING
AALBORG UNIVERSITETSCENTER · AUC · AALBORG · DANMARK

INDOOR ENVIRONMENTAL TECHNOLOGY
PAPER NO. 6

Presented at the 3rd Seminar on »Application of Fluid Mechanics in Environmental Protection
-88», Silesian Technical University, Gliwice, Poland

PETER V. NIELSEN, ÅKE T. A. MÖLLER
MEASUREMENTS ON BUOYANT JET FLOWS FROM A CEILING-MOUNTED SLOT DIF-
FUSER
NOVEMBER 1988

ISSN 0902-7513 R8832

MEASUREMENTS ON BUOYANT JET FLOWS FROM
A CEILING-MOUNTED SLOT DIFFUSER

Peter V. Nielsen, University of Aalborg, Denmark
Åke T.A. Möller, Stifab AB, Tomelilla, Sweden

INTRODUCTION

Ceiling-mounted slot diffusers in ventilated rooms will often generate a flow of the wall jet type. The jet follows the ceiling, entrains air from the occupied zone and generates a re-circulating flow in the whole room.

This paper will deal with the flow in the ceiling region. The wall jet flow is especially influenced by diffuser design and surrounding details such as distance to the ceiling and the ceiling structure. The flow is less influenced by other parameters in the room such as length, width, height and furnishings.

It is important to study the conditions and locations where the flow can be described as a wall jet. This description is useful when different diffusers are compared, and it is the background for calculation of "throw" and "penetration depth", see (1). It is also convenient to use the wall jet description of inlet conditions in computer predicted flow in rooms. This description makes it possible to ignore details at the diffuser as e.g. vanes resulting in reduction of computer storage and increased computation speed, see ref. (2).

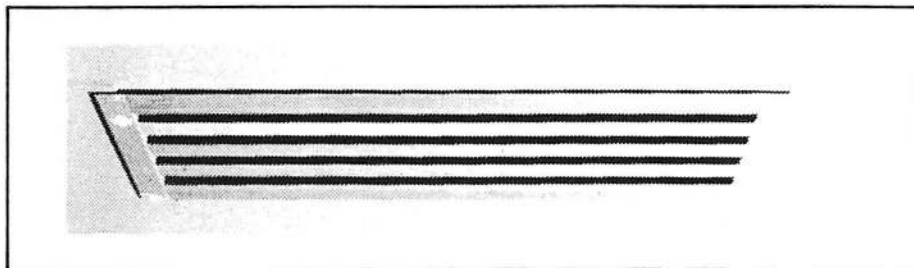

Fig. 1. Ceiling-mounted slot diffuser with small width.

DIFFUSER

Fig. 1 shows one of the diffusers used for the measurements in the paper. The diffuser has four adjustable openings, and it is possible to direct the flow either in two horizontal directions or vertically downwards. The experiments in this

paper describe situations where all the flow is in the same horizontal direction, or situations where the flow is divided in two horizontal directions. The main part of this paper describes the last mentioned situation.

The paper will deal with the two-dimensional flow from a slot diffuser and also the transition to three-dimensional flow in case of a slot diffuser with small width. The experiments are therefore made with two slot diffusers of the same type, but with different widths.

SLA 4 - 60 width: 0.60 m

SLA 4 - 180 width: 1.80 m

WALL JET FLOW

A two-dimensional wall jet flow is a flow established close to a surface where air is supplied parallel to the surface from a slot with a large width. The wall jet conditions are fulfilled when the velocity profiles can be expressed in a single universal profile normalized with a local length and a local velocity and when growth rate and velocity decay can be expressed by the following equations, see Rajaratnam (3) and Schwarz and Cosart (4).

$$\frac{\delta}{h} = D_p \frac{x+x_0}{h} \quad (1)$$

$$\frac{u_x}{u_0} = K_p \sqrt{\frac{h}{x+x_0}} \quad (2)$$

δ is the wall jet thickness perpendicular to the surface at the velocity $u_x/2$, where u_x is the local maximum velocity. x is the length from the opening and h is the slot height. x_0 is the virtual origin of the wall jet growth and velocity decay, while D_p and K_p are constants and u_0 is the supply velocity.

x_0 is small compared to the distance x in the wall jet, and equation (1) shows that the growth of the wall jet thickness is in practice proportional to the distance from the opening with the growth rate D_p . Equation (2) shows that the velocity ratio u_x/u_0 is proportional to $1/\sqrt{x}$, which is typical of a two-dimensional wall jet, and it expresses that the momentum flow is preserved in the jet.

A thermal two-dimensional wall jet can be described by equations (1) and (2), and by the following equation for the temperature distribution

$$\frac{T_x - T_R}{T_o - T_R} = K_{pT} \sqrt{\frac{h}{x+x_o}} \quad (3)$$

where T_x is the wall jet extreme temperature at the distance x from the diffuser, T_o is the supply temperature and T_R the room or the return temperature. K_{pT} is a constant for the wall jet.

The theory behind the wall jet assumes that the flow has a fully developed turbulent level, which also means that the normalized flow (velocity, turbulence) is independent of the Reynolds number. The general turbulent flow in ventilated rooms is often fully developed, see Hanel and Scholz (5), but diffusers may in some cases be used at low supply velocities giving a jet which is not fully developed. The equations (1), (2) and (3) are in this case used with D_p , K_p and K_{pT} -factors which are functions of the supply velocity u_o or functions of the Reynolds number for the diffuser, see ref. (6).

A Reynolds number for the diffuser can be expressed by

$$Re = \frac{u_o h}{\nu} \quad (4)$$

where ν is the kinematic viscosity. This expression for the Reynolds number makes it possible to compare different sizes of the same type of diffuser, but it is not possible to compare two different designs.

When the air distribution system has to remove heat from a source in the room it will result in a flow with a thermal wall jet. The flow in the wall jet will in this case be dependent on the diffuser and the Archimedes number Ar , and it might be dependent on the Reynolds number at small supply velocities, but independent at higher velocity levels, see Müllers (7). The Archimedes number is given by

$$Ar = \frac{\beta g h \Delta T_o}{u_o^2} \quad (5)$$

where β , g and ΔT_o are the coefficients of thermal expansion, gravitational acceleration and temperature difference between return and supply, respectively. The Archimedes number will in this paper be expressed by the following factor

$$\frac{\Delta T_o h}{u_o^2} \quad \left(\frac{Ks^2}{m} \right) \quad (6)$$

A three-dimensional jet can be expected far downstream in the flow from the diffuser with the small width. This will influence the velocity u_x and the T_x , and the velocity will in this

case be expressed by the following equation (7) instead of equation (2)

$$\frac{u_x}{u_0} = K_a \frac{\sqrt{a_0}}{x+x_0} \quad (7)$$

a_0 is the supply area and K_a is a constant. The equation shows that the velocity ratio u_x/u_0 is proportional to $1/x$, which is typical of a three-dimensional wall jet.

MEASUREMENTS AND DISCUSSION

All the measurements are made in a room which fulfils the Swedish regulation SP VVS 17 1973 on "Test of supply and return openings". The room dimensions are 12 m × 12 m × 3 m and the diffusers are mounted in the ceiling 6 m from each side wall.

SLOT HEIGHT

The slot height h and the supply velocity u_0 are to be typical values for determination of the momentum flow from the slot diffuser.

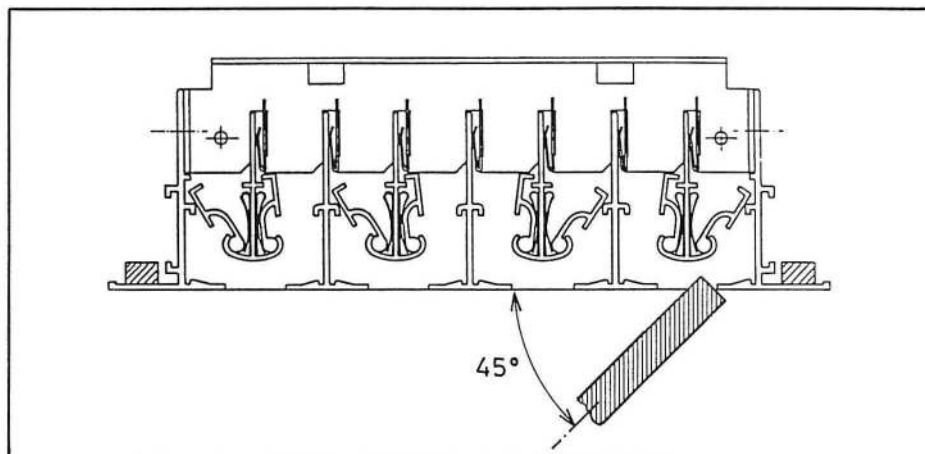

Fig. 2. Cross section of the ceiling-mounted slot diffuser and location of the hot wire instrument for measuring the supply velocity.

Fig. 2 shows the location of the hot wire instrument for measuring a supply velocity. This location of the instrument gives a maximum value, and the supply velocity u_0 is found as the mean value of more measurements along the slot. The slot height is found from the equation

$$h = 0.001 \frac{q_0}{\ell \cdot u_0} \quad (\text{m}) \quad (8)$$

where q_0 (ℓ/s) is the supply flow from the slot diffuser in the given direction and ℓ (m) is the slot width. (The slot height h is thus different from the geometrical openings in the diffuser).

It is important to use the same measuring points for all determinations of u_0 in different experiments.

ISOTHERMAL WALL JET FROM THE SLA 4-180 DIFFUSER

The velocity profiles are measured at different distances from the diffuser and u_x , δ and x_0 are obtained from the measurements. K_p is established from a determination of the maximum velocity u_x as a function of the distance x from the diffuser. It is convenient to ignore the distance x_0 to the virtual origin because it is small compared to the length of the jet. All the K_p -values in this paper are therefore calculated for x_0 equal to zero ($x_0 = 0.0$ in equation (2) and (7)).

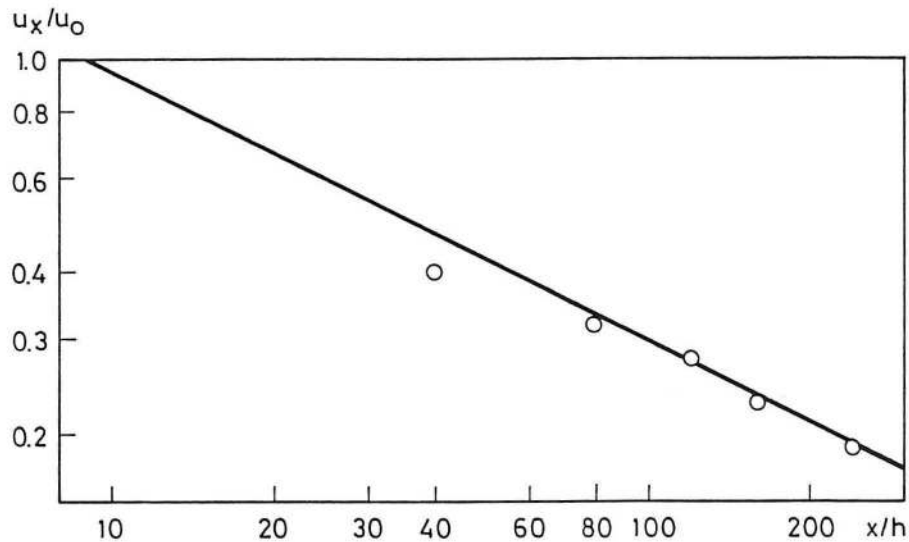

Fig. 3. Velocity decay in the isothermal wall jet from a slot diffuser with large width, $\ell = 1.80$ m. The diffuser is adjusted to two horizontal wall jets, $q_0 = 66$ ℓ/s in the measured direction.

The diffuser is adjusted to two horizontal wall jets in opposite directions in the measurements.

The measurements on the diffuser with large width show on average a K_p -factor of 2.8. The value is rather independent of the Reynolds number for flows between 52 and 99 l/s. Fig. 3 shows a typical set of measurements. The velocity is proportional to $1/\sqrt{x}$ over the whole distance x , as should be expected in a two-dimensional wall jet. (The slope of the line in fig. 3 is equal to -0.5).

ISOTHERMAL WALL JET FROM THE SLA 4-60 DIFFUSER

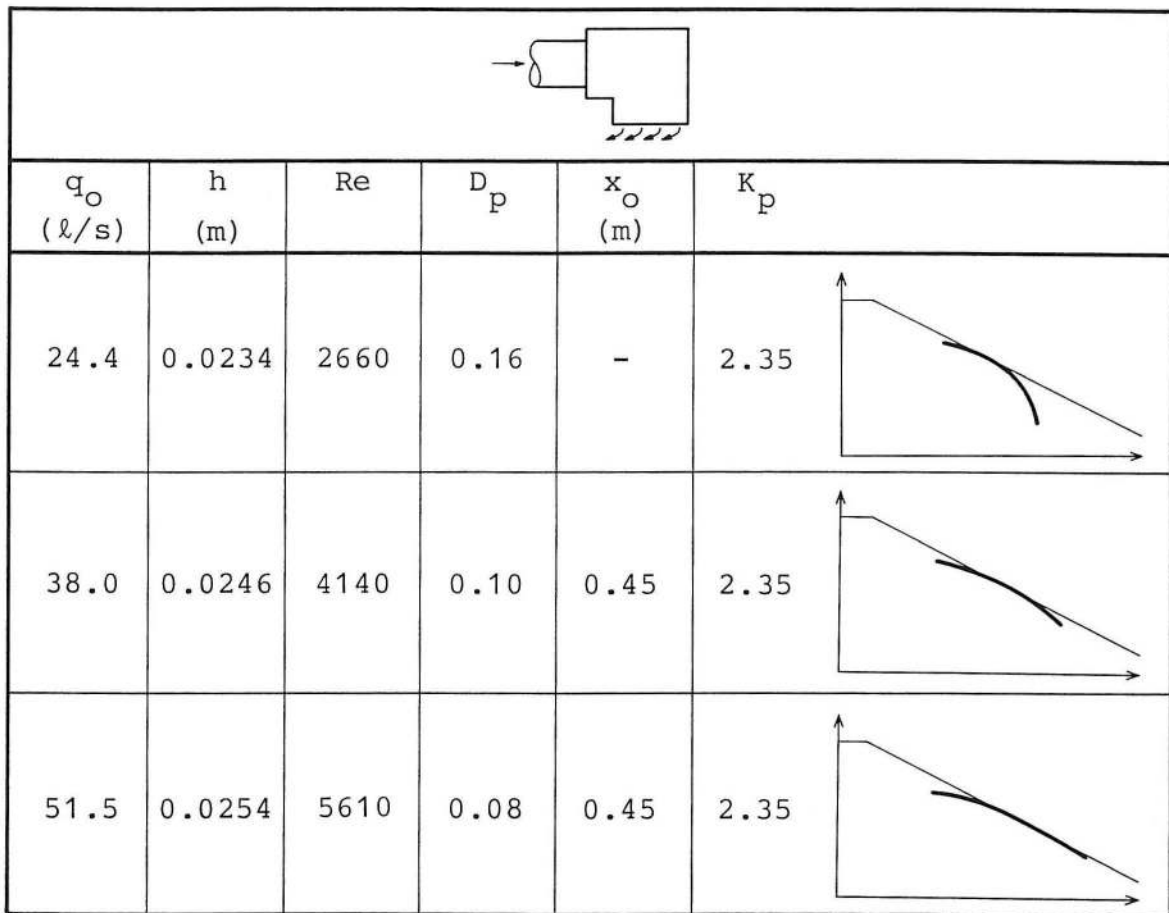

Fig. 4. Measurements of the isothermal wall jet from a slot diffuser with small width, $l = 0.6$ m. The diffuser is adjusted for a single horizontal wall jet.

Fig. 4 shows the measurements on the slot diffuser with small width, $l = 0.6$ m. The diffuser is adjusted for a single horizontal wall jet. It should first be observed that the growth rate D_p is a significant function of the Reynolds number. A D_p -value of 0.16 is rather high, and the small sketch of

velocity versus distance shows an atypical velocity decay for a two-dimensional wall jet. The flow is not fully developed, but it is still advantageous to use the wall jet theory because velocities calculated according to equation (2) are higher than or equal to the measured velocities. Therefore they will be safe values for design procedures. The D_p -values and the velocity decay for an increased flow ($q_o = 38.0$ and 51.5 ℓ/s) are more typical for a fully developed two-dimensional wall jet, references (2), (4) and (8).

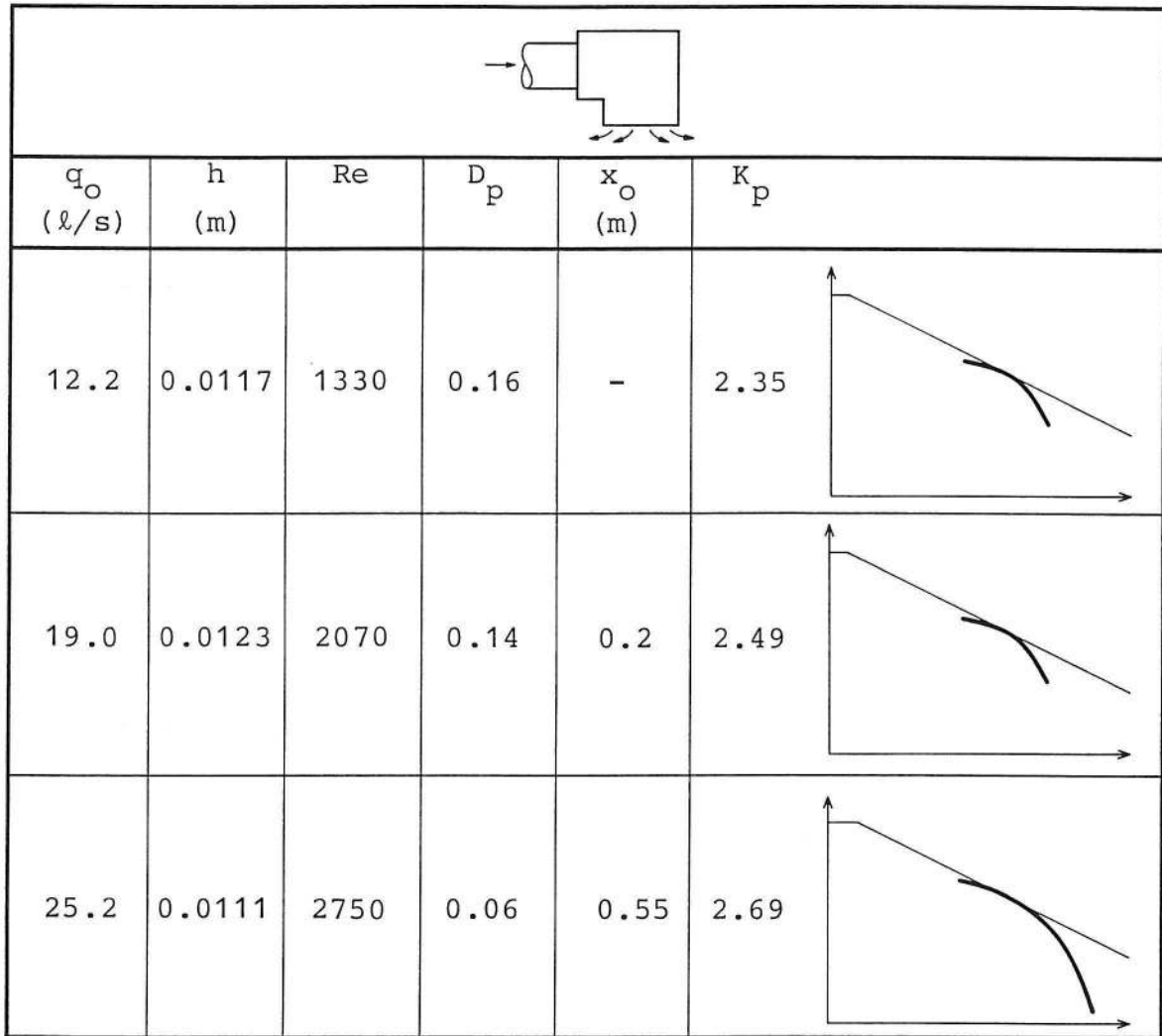

Fig. 5. Measurements of the isothermal wall jet from a slot diffuser with small width, $\ell = 0.6$ m. The diffuser is adjusted to two horizontal wall jets.

Fig. 5 shows the measurements for the diffuser adjusted to two horizontal wall jets in opposite directions. The growth rate D_p is a function of the Reynolds number, and the value for the highest volume flow is typical for a fully developed wall jet. The sketches of the velocity versus distance show a velocity decay which exceeds $1/\sqrt{x}$. It may be assumed that the flow is changing to a three-dimensional flow, and an adoption to equation (7) gives a K_a -value of 4.1 for $q_0 = 25.2$ l/s and $x_0 = 0.0$ m

It is typical of the SLA 4-60 diffuser and the SLA 4-180 diffuser that the distance x_0/h is large compared to the values for a more conventional slot design and the K_p -factor is lower, see references (2), (4) and (8). A low K_p -factor means a low velocity at a given distance x and thus a high entrainment of air into the jet. The air distribution system can handle a high volume flow at low velocities in the room.

PENETRATION DEPTH

An undisturbed wall jet will penetrate the ventilated room in the case of isothermal flow and will entrain air from the occupied zone to induce recirculation air movement in the room. This picture will change when a thermal load is supplied to the room. The supply temperature will be reduced and the load may reach a level such that the wall jet will separate from the ceiling at a distance x_s from the diffuser and flow down into the occupied zone. Situations with a short penetration depth are undesirable, because the jet may have a high velocity and a low temperature when it flows into the occupied zone, and a calculation of the penetration depth is thus a part of the design procedure of the air distribution system.

Grimitlin, ref. (9), has shown that the penetration depth for a cold two-dimensional wall jet is proportional to $1/(Ar)^{2/3}$. The measurements in fig. 6 confirm the linear relationship between x_s/h and $1/(Ar)^{2/3}$, for the short as well as for the wide diffuser.

An analysis of the forces acting on a non-isothermal horizontal wall jet leads to the following equation

$$\frac{x_s}{h} \sim \left(\frac{K_p^2}{D_p K_{pT}} \right)^{2/3} \left(\frac{u_0^2}{h \cdot \Delta T_0} \right)^{2/3} \quad (9)$$

If it is assumed that K_{pT} is proportional to K_p and that D_p is proportional to $1/K_p^2$ (constant momentum flow in a wall jet) it is possible to set up the equation

$$\frac{x_s}{h} = K_{sp} \cdot K_p^2 \left(\frac{u_0^2}{h \cdot \Delta T_0} \right)^{2/3} \quad (10)$$

where K_{sp} is a constant dependent on parameters outside the wall jet, such as room dimensions, location of thermal load, etc.

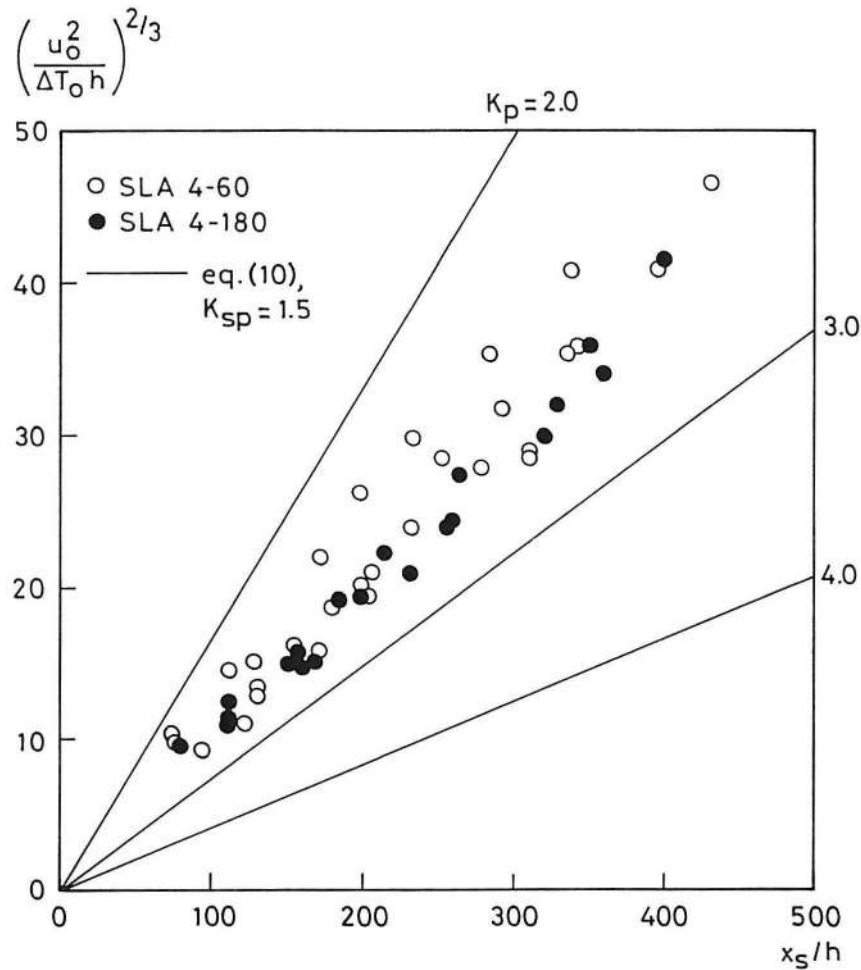

Fig. 6. Measurements of the normalized penetration depth x_s/h versus $1/(Ar)^{2/3}$ for a wall jet established by the diffuser shown in fig. 1 and fig. 2. The diffuser is adjusted for two horizontal wall jets.

Measurements by Hestad, ref. (10), give a K_{sp} -value of 1.5 in the case of an evenly distributed heat source along the floor. The measurements in this paper are made by the same type of heat load and they confirm the K_{sp} -value of 1.5 as indicated in fig. 6.

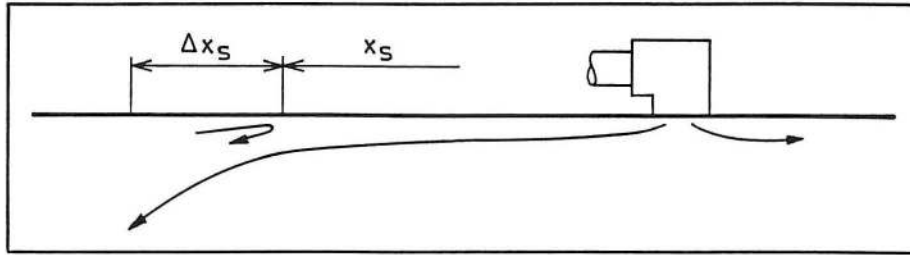

Fig. 7. Sketch of wall jet and penetration depth x_s .

The practical use of equation (10) is complicated because the jet air flow from different diffusers has different flow patterns in the area where it leaves the ceiling region and penetrates into the occupied zone, see reference (11). The penetration depth x_s for the linear slot diffuser is measured as the distance up to the area where the entrainment flow meets the jet at the ceiling surface (separation line). The jet travels a further distance Δx_s before it flows down into the occupied zone, where Δx_s is typically about 2 - 2.5 m.

CONCLUSIONS

Measurements on ceiling-mounted slot diffusers show that the flow along the ceiling can be described as a wall jet although the flow is dependent on the Reynolds number for most of the tests ($1.5 < u_0 < 3.0$ m/s).

The velocity decay and the distance to the virtual origin are typically larger for this ceiling-mounted slot diffuser compared to the values for a more conventional slot design.

The wall jet from the diffuser with short width (0.6 m) shows a tendency towards three-dimensional flow over long distances from the diffuser.

The penetration depth is a function of the Archimedes number. Measurements show that the penetration depth x_s is proportional to $1/(Ar)^{2/3}$ and, furthermore, comparisons with other measurements show that the penetration depth x_s can be assumed to be proportional to the diffuser coefficient K_p in the second power.

REFERENCES

- (1) Nielsen, P.V. and Möller, Å.T.A., New Developments in Room Air Distribution. In A.F.C. Sherratt (Ed.), Air Conditioning System Design for Buildings, McGraw-Hill, England, 1983, 200-219.
- (2) Nielsen, P.V., Bestimmung der maximalen Luftgeschwindigkeit in der Aufenthaltszone eines klimatisierten Raumes. Heizung Lüftung/Klimatechnik Haustechnik, No. 9, 1980.
- (3) Rajaratnam, N., Turbulent Jets. Elsevier, Amsterdam, 1976.
- (4) Schwarz, W.H. and Cosart, W.P., The Two-Dimensional Turbulent Wall-Jet, J. Fluid. Mech., vol. 10, p. 481, June 1961.
- (5) Hanel, B. and Scholz, R., Beitrag zur Modellierung zweidimensionaler isothermer und nichtisothermer turbulenter Strömungen in Räumen. Luft- und Kältetechnik, Nr. 3 and 4, 1979.
- (6) Nielsen, P.V. and Möller, Å.T.A., Measurement of the three-dimensional wall jet from different types of air diffusers, World congress on heating, ventilating and air-conditioning, Copenhagen, 1985.
- (7) Müllejans, H., Über die Ähnlichkeit der nicht-isothermen Strömung und der Wärmeübergang in Räumen mit Strahllüftung, Diss. T.H. Aachen, 1963.
- (8) Hammon, G.P., Complete Velocity Profile and Optimum Skin Friction Formulae for the Plane Wall-Jet. Report SME/J/80/01, Cranfield School of Mechanical Engineering, 1980.
- (9) Grititlin, M., Zuluftverteilung in Räumen. Luft- und Kältetechnik, Nr. 5, 1970.
- (10) Hestad, T., Design of Supply Openings, Cold Draught (in Norwegian), Norsk VVS, No. 6, 1976.
- (11) Nielsen, P.V. and Möller, Å.T.A., Measurements on Buoyant Wall Jet Flows in Air-Conditioned Rooms, Room Vent 87, International conference on Air Distribution in Ventilated Spaces, Stockholm, 1987.

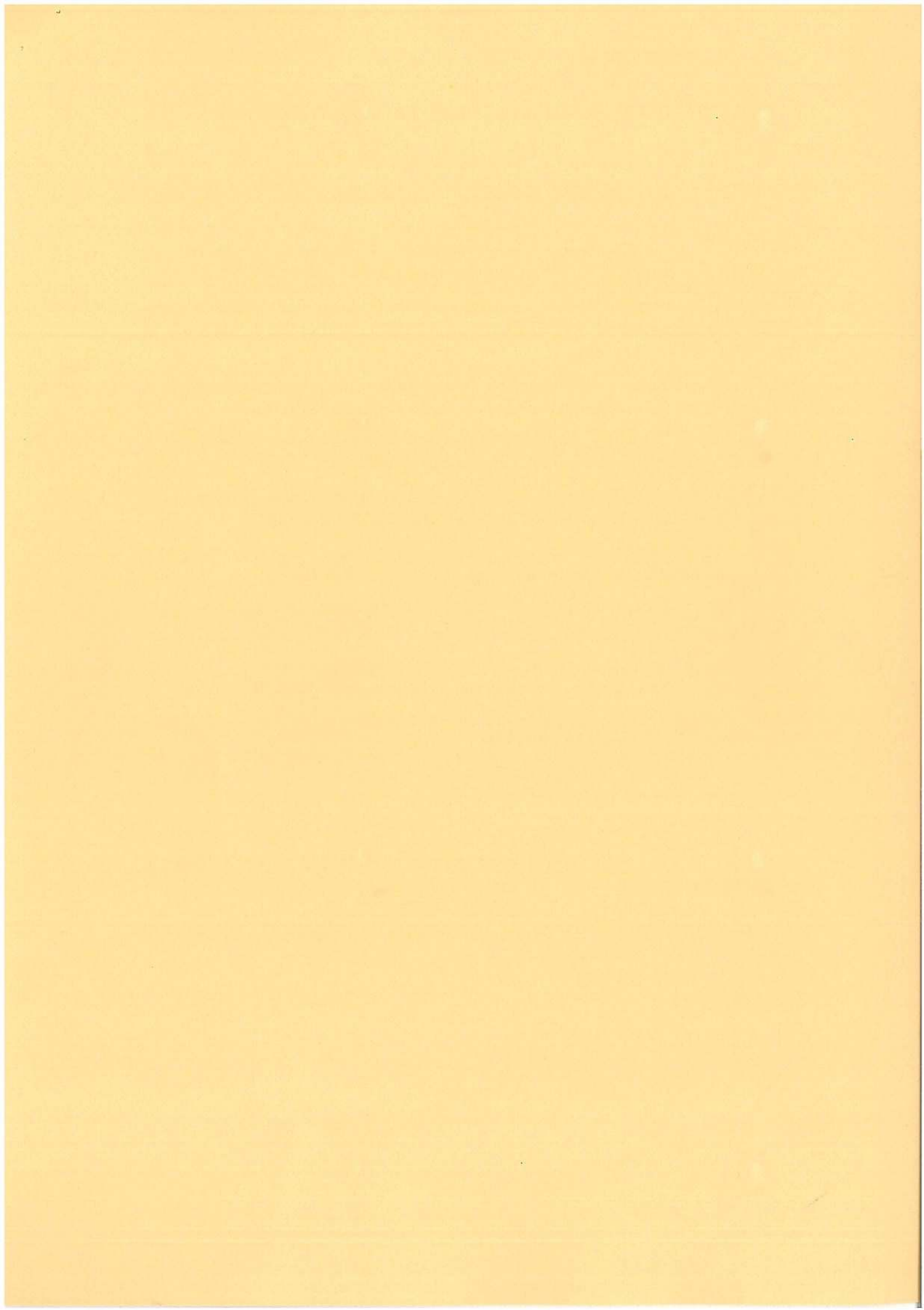

PAPERS ON INDOOR ENVIRONMENTAL TECHNOLOGY

PAPER NO. 1: C. E. Hyldgård: *Aerodynamic Control of Exhaust*. ISSN 0902-7513 R8712.

PAPER NO. 2: Per Heiselberg, Peter V. Nielsen: *The Contaminant Distribution in a Ventilated Room with Different Air Terminal Devices*. ISSN 0902-7513 R8713.

PAPER NO. 3: Peter V. Nielsen, L. Evensen, Peter Grabau, J. H. Thulesen-Dahl: *Air Distribution in Rooms with Ceiling-Mounted Obstacles and Three-Dimensional Flow*. ISSN 0902-7513 R8714.

PAPER NO. 4: Peter V. Nielsen, Åke T. A. Möller: *Measurements on Buoyant Wall Jet Flows in Air-Conditioned Rooms*. ISSN 0902-7513 R8715.

PAPER NO. 5: Peter V. Nielsen: *Numerical Prediction of Air Distribution in Rooms. Status and Potentials*. ISSN 0902-7513 R8823.

PAPER NO. 6: Peter V. Nielsen, Åke T. Möller: *Measurements on Buoyant Jet Flows from a Ceiling-Mounted Slot Diffuser*. ISSN 0902-7513 R8832.

PAPER NO. 7: Peter Kofoed, Peter V. Nielsen: *Thermal Plumes in Ventilated Rooms - An Experimental Research Work*. ISSN 0902-7513 R8833.

PAPER NO. 8: Peter V. Nielsen, Lars Hoff, Lars Germann Pedersen: *Displacement Ventilation by Different Types of Diffusers*. ISSN 0902-7513 R8834.

PAPER NO. 9: Per Heiselberg, Peter V. Nielsen: *Flow Conditions in a Mechanically Ventilated Room with a Convective Heat Source*. ISSN 0902-7513 R8835.

PAPER NO. 10: Peter V. Nielsen: *Displacement Ventilation in a Room with Low-Level Diffusers*. ISSN 0902-7513 R8836.

**INSTITUTE OF BUILDING TECHNOLOGY AND STRUCTURAL
ENGINEERING**

THE UNIVERSITY OF AALBORG

SOHNGAARDSHOLMSVEJ 57, DK-9000 AALBORG

TELEPHONE: + 45 8 14 23 33

TELEFAX: + 45 8 14 82 43

TELEX: 69523