

Mechanical properties of suture materials in general and cutaneous surgery

The Faculty of Oregon State University has made this article openly available.
Please share how this access benefits you. Your story matters.

Citation	Naleway, S. E., Lear, W., Kruzic, J. J., & Maughan, C. B. (2015). Mechanical properties of suture materials in general and cutaneous surgery. <i>Journal of Biomedical Materials Research Part B: Applied Biomaterials</i> , 103(4), 735-742. doi:10.1002/jbm.b.33171
DOI	10.1002/jbm.b.33171
Publisher	John Wiley & Sons Ltd.
Version	Accepted Manuscript
Terms of Use	http://cdss.library.oregonstate.edu/sa-termsfuse

Mechanical properties of suture materials in general and cutaneous surgery

Steven E. Naleway,¹ William J. Lear,² Jamie J. Kruzic,¹ Cory Maughan²

¹Materials Science, School of Mechanical, Industrial, and Manufacturing Engineering, Oregon State University, Corvallis, Oregon 97330

²Silver Falls Dermatology, Salem, Oregon 97302

ABSTRACT

Comprehensive studies comparing tensile properties of sutures are over 25 years old and do not include recent advances in suture materials. Accordingly, the objective of this paper is to investigate the tensile properties of commonly-used sutures in cutaneous surgery. Thirteen 3-0 sized modern sutures (four non-absorbable and nine absorbable) were tensile tested in both straight and knotted configurations according to the procedures outlined by the United States Pharmacopeia. Glycomer 631 was found to have the highest failure load (56.1 N) of unknotted absorbable sutures, while polyglyconate (34.2 N) and glycomer 631 (34.3 N) had the highest failure loads of knotted absorbable sutures. Nylon (30.9 N) and polypropylene (18.9 N) had the greatest failure loads of straight and knotted non-absorbable sutures, respectively. Polydioxane was found to have the most elongation prior to breakage (144%) of absorbable sutures. Silk (8701 MPa) and rapid polyglactin 910 (9320 MPa) had the highest initial modulus of non-absorbable and absorbable sutures, respectively. The new data presented in the study provides important information for guiding the selection of suture materials for specific surgeries.

KEYWORDS

Sutures, strength, elongation, modulus, tensile properties

INTRODUCTION

Sutures are used on a daily basis in cutaneous surgery for a wide variety of purposes. The basic mechanical properties of the suture materials are important for the overall suture function and appropriate suture selection. The ideal suture material should not break unexpectedly during use, elongate with wound edema, be biocompatible, handle easily, form a secure knot, and, if used internally, biodegrade in an appropriate time course. Knowledge of the tensile mechanical properties of the various suture materials allows one to evaluate the first two of these characteristics. Of the commonly-cited mechanical properties of sutures, the most important are the basic tensile properties.

Most published reports on the tensile behavior of various sutures focus only on the breaking force. Detailed reports comparing other important tensile properties such as failure elongation, failure stress, failure strain, modulus, and full stress-strain curves across suture materials are quite limited. The comprehensive studies that are available were performed on sutures that are much less relevant to cutaneous surgery and do not include recent advances in suture materials.^{1,2} Most available studies on modern sutures were conducted as head-to-head comparisons of only a few suture materials that often only reported strength, focused on specific pre-storage conditions, and/or did not consider the effect of knotting.³⁻¹³ As a result of the differences in testing methodologies, it is often inappropriate to compare the currently available results in a comprehensive manner. For example, were a surgeon to look for the failure strength of a glycomer 631 suture, a basic literature review would produce varying and potentially confusing results. Results would include a baseline measurement of 3.08 N for a 5-0 gauge suture tested *in vivo* and *in vitro* in rats where tensile strength was measured on tensile meter,¹⁴ maximum tensile

loads ranging from 6 to 15 kgf for a 4-0 gauge suture tested *ex vivo* after 0 to 21 days *in vivo* in a pig where tensile strength was measured by testing skin samples with embedded sutures,¹⁵ and tensile loads of 88.0 to 141.6 N for 0-0 and 2-0 sutures tested in five different knot configurations and soaked in 0.9% sodium chloride for 60 seconds where tensile strength was measured on an Instron testing instrument.¹⁶ While each of these tests provide valuable insight into their specific research objectives, together, their variety of testing conditions, tensile strength measurement procedures, and gauge sizes could provide confusion for a surgeon in search of a simple answer. This process would only be further complicated if a comparison between suture materials was desired. To date, no study has examined the tensile properties of available modern cutaneous suture materials in a rigorous and comprehensive manner so as to provide a resource for the comparison of suture materials. Accordingly, it is the goal of the present paper to compare an array of tensile mechanical properties for modern cutaneous sutures tested in a consistent and controlled manner following the United States Pharmacopia (USP) standards in order to produce standardized and repeatable results.¹⁷ The results and discussion herein are intended by the authors to provide a baseline data set for surgeons compiling the tensile mechanical properties of available sutures at a controlled and specific set of testing conditions to allow for easy comparison.

METHODS

Materials

Sutures of four non-absorbable and nine absorbable materials were procured from Physician Sales and Service. Suture materials, trade names, manufacturer names and locations, lot numbers

and expiration dates are listed in Table 1. All sutures were purchased new and variations in the expiration dates are considered as variations in the shelf life of the suture material. All sutures were purchased at the same 3-0 gauge and each suture was checked to be free of damage and within its expiration date prior to testing. In every case sufficient sutures were purchased to allow for ten ($N = 10$) repeat tests to be conducted for each test type.

Testing Procedures

Prior to testing, the diameter of each suture was measured using a digital micrometer. The diameter was measured three times ($N = 3$) along the active length as described by the USP suture diameter standard.¹⁸ A mean diameter was calculated and utilized for all data analysis. So as to minimize the total time between the removal of each suture from its sterile packaging and testing, each suture had its needle removed, was individually measured and tested immediately in accordance with the USP standard for determining tensile strength of sutures.¹⁷ For dry sutures the total time between the removal of the suture from the sterile package and the completion of the test was no greater than five minutes. In the case of sutures packaged in alcohol (both the chromic gut and plain gut suture types) the time between removal of the suture from its packaging and testing was no greater than two minutes to avoid drying of the suture before testing, as specified by the USP.

Sutures were tested on a computer-controlled servo-hydraulic Instron 8501 mechanical testing machine (Instron Corporation, Norwood, MA, USA) utilizing an Instron 2527-131 dynamic 250 N load cell (Instron Corporation, Norwood, MA, USA). The load cell was calibrated prior to all testing. Sutures were attached using custom aluminum tensile mounts (Figure 1) similar to those used by other researchers in previous studies of suture tensile behavior.^{2,19} In all cases the active

length was set at $l_0 = 60$ mm and failure occurred near the center of the active length indicating the gripping points did not affect the results. Sutures were attached to each tensile mount by tying the suture to the cross bar of the tensile mounts then wrapping two to four times (depending upon total suture length) along the shaft of the tensile mount (see Figure 1). In the cases of polybutester, nylon, polypropylene, and polyglactin 910 sutures, due to the low surface friction of these suture materials; tape was used to bond the free ends of the suture to the tensile mount. In these cases the tape was fixed to the cross bar at the very end of the suture away from the active length so as to not interfere with testing and tape, if used, was used in all repeat tests. The sutures always failed near the center of the active length indicating the gripping points did not affect the results.

All tests were performed under displacement control at a cross-head speed of two times the active area, or 120 mm, per minute as specified by the USP standard for tensile strength.¹⁷ Each test was performed in ambient air with an average temperature (\pm standard deviation) of 27.1 ± 2.3 °C and average relative humidity (\pm standard deviation) of 32.9 ± 5.2 . For each suture material, a total of twenty sutures ($N = 20$) were tested using two configurations: 1) ten as straight-pull tests ($N = 10$) and 2) ten as knot-pull tests ($N = 10$) with single over hand throw simple knot placed at the center of the active length. Based on the measured standard deviations, repeatability was essentially identical to previous studies (e.g., von Fraunhofer *et al.*¹⁹) that used the same basic test procedures and gripping fixtures. While other test configurations may be of interest for specific cutaneous surgery applications, these two configurations are the standard tests required by the USP standard for tensile strength.¹⁷ The results of the testing performed qualify as level IIA evidence, or evidence from a controlled study without randomization.

In all cases, load and elongation were collected throughout testing until failure. The results are initially presented in this form, as this is a common method of presenting mechanical property data in surgical articles concerning sutures materials. In addition, and as a result of the fact that many sutures tested did not conform to the USP standard for 3-0 gauge diameter, the results were converted and presented in a size independent manner. The load data was converted to engineering stress by dividing the applied load, P , by the initial cross-sectional area, A . Also, elongation data was converted to engineering strain by dividing the extension, or change in active length Δl , by the original active length, l_0 . Finally, the initial modulus, E , was calculated for all sutures as the initial slope of the stress versus strain curve. Due to the biphasic nature of polybutester and nylon sutures, where there are two low strain moduli present, both an initial and secondary modulus were determined.

Results were analyzed using a two-way ANOVA to determine the effect of suture type and test condition (straight- or knot-pull) and if there was an interaction effect. To determine pair-wise statistical differences, post-hoc analysis was done using Tukey's test and $p < 0.05$ was considered statistically significant.

RESULTS

The results of a two-way ANOVA statistical analysis revealed statistically significant effects of suture type and test type with a statistically significant interaction in all major data sets (failure load, percent elongation to failure, failure stress, failure strain, and initial modulus). The significant interaction indicates that knotting does not have the same magnitude effect across all suture types. Mean and standard deviation values of diameter (in mm), failure load (in N),

percent elongation to failure (in %), failure stress (in MPa or $\text{N/m}^2 \times 10^6$) and failure strain are presented for all suture types in Table 2. In addition, Table 2 displays the results of the post-hoc statistical analysis. For each of the results, mean values without statistically significant differences are identified by matching superscript letters. Most 3-0 gauge sutures are expected to have a standard diameter in the range of 0.2 – 0.249 mm based on the USP standards, while 3-0 absorbable collagen sutures (plain gut and chromic gut in this study) are expected to be of larger diameter in the 0.3 – 0.339 mm range.^{20,21} Overall, mean diameters for the sutures measured in this study varied from 0.318 to 0.154 mm and many did not conform with the USP criteria (Table 2). This variation in diameter affects the resultant failure stresses of the sutures due to the inverse relationship between stress and diameter.

Curves for non-absorbable suture materials are presented for both the straight-pull and knot-pull configurations comparing load to elongation in Figure 2-A and stress to strain in Figure 2-B. Suture materials are ordered by increasing tensile failure load from left to right in both Figure 2-A and Figure 2-B. In both cases, the displayed curve is for the suture with approximately the median failure load defined by the fifth largest tensile failure load out of ten tests. In addition, the average and standard deviation failure load and elongation results for each test type and suture are presented in Table 2.

Curves for absorbable suture materials are presented for both the straight-pull and knot-pull configurations comparing load to elongation in Figure 3-A and stress to strain in Figure 3-B. Suture materials are ordered by increasing tensile failure load from left to right in both Figure 3-A and Figure 3-B. As in Figure 2, the displayed curve is representative of the suture with an approximate median tensile failure load defined by the fifth largest tensile failure load out of ten

tests. In addition, the average and standard deviation failure stress and strain results for each test type and suture are presented in Table 2.

The initial moduli results are displayed in Table 3. Polybutester and nylon sutures showed a biphasic behavior with two different moduli in the low stress regime. Accordingly, for the non-absorbable sutures plots are shown to demonstrate how two separate moduli were determined for the biphasic sutures compared to the normal behavior sutures (Figure 4).

DISCUSSION

This is the first comprehensive study of the mechanical properties of commonly-used sutures in cutaneous surgery in over 25 years.^{1,2} Advancements in polymer chemistry have created many improvements, particularly in absorbable sutures.²² This study provides a baseline that will allow surgeons to make an informed decision in precisely choosing the mechanical properties appropriate for a given surgery. It also provides a baseline to which one can compare newly developed sutures in the future.

The current study kept the suture gauge designation constant at 3-0 in order to facilitate comparisons of a single gauge of suture as would be purchased by a practicing doctor.

Commonly-used gauges of cutaneous sutures are usually in the range of 00 (2-0) through 000000 (6-0) with an increasing number of zeros making reference to smaller and weaker gauges of suture. Ideally they should follow the United States Pharmacopia (USP) classification of suture size,^{20,21} however, many sutures are clearly labeled that they do not conform to the USP diameter standards (Table 1). Additionally, as shown in Table 2, there can be a great deal of variability in the diameter of 3-0 sutures. This lack of adherence to the USP diameter standards is likely

inconsequential to surgeons who will have experience with the suture performance of a specific gauge regardless of actual measured diameter. However, the variation in the actual measured diameters is important as it affects the calculated material properties and can potentially help a surgeon select the correct suture gauge when switching among suture materials. Indeed, there are implications for the engineering stress-strain behavior as well as the modulus, since these values are normalized for the diameter of the suture. The current study presents stress-strain data to illustrate differences in the sutures that can be attributed solely to the material type. For the purposes of the practicing surgeon choosing amongst a specific gauge size, without access to the true diameter data, the non-normalized load-elongation curves are more useful. However, if, for example, a surgeon wished to switch to a thinner suture while maintaining high strength, knowledge of the failure stress can help inform that decision and allow the selection of the highest strength material independent of diameter. Overall, when equipped with accurate diameter and failure stress information the practicing surgeon may choose to select a different suture size when switching between materials in order to achieve the desired result.

Knotting is well known to affect suture strength and the effect is demonstrated clearly in this study. A single knot decreased the failure load of nylon and polypropylene sutures by 62% and 19% respectively as shown in Table 2. The immediate implication of these results is that while nylon had the highest unknotted failure load of any non-absorbable suture in this study, polypropylene had the highest knotted failure load, which is arguably more important when the suture has been knotted *in vivo*. However, when using a suture as a temporary “pulley suture” to initially close a wound under great tension, the stronger nylon may be a better choice.

It is important to note that the strength of knotted sutures, as measured in this study, differs from knot strength. Knot strength refers to the ability of a knot to withstand being pulled apart.²³

Accordingly, to measure knot strength a suture would be knotted in a closed loop and then a load applied to open the suture loop.²³ In this study, the load is applied to the ends of a suture with a single knot in the middle in accordance with the USP tensile strength standard.¹⁷ This is a measure of how the knot decreases the strength of the suture rather than of how securely the suture can be knotted.

For absorbable sutures, poliglecaprone was most affected by a single knot (57% drop in failure load as shown in Table 2). Glycomer 631 had the highest failure load of unknotted absorbable sutures, while polyglyconate and glycomer 631 had the highest failure load of knotted absorbable sutures. Thus, these would make these good choices for high tension areas, such as scalp closures. Of unknotted and knotted absorbable suture materials, polydioxane and polyglyconate allowed for the most elongation prior to breaking respectively. These findings support the current surgical practice; use of flexible polydioxanone sutures for continuous midline abdominal fascial closure with adequate suture length to wound length results in favorable outcomes.²⁴ Increased elongation would be advantageous in situations where a great deal of edema is expected postoperatively. To what degree this elongation is elastic, or could return to a less elongated state after the load is removed, cannot be deduced from this study.

The stress-strain curves as shown in Figures 2B and 3B provide the stress-strain relationship of the material as they take into consideration the diameter of the material. Polyglactin 910 (regular and rapid dissolving) and silk have the highest failure stresses among absorbable and non-absorbable sutures, respectively, once normalized for their smaller diameters. These smaller diameters corresponded to braided sutures of silk and polyglactin 910 materials where mean diameters ranged from 0.145 to 0.189 mm. In addition, the non-absorbable monofilament suture

types exhibited smaller diameters, with mean diameters ranging from 0.245 to 0.248 mm, than absorbable monofilament sutures, with mean diameters ranging from 0.286 to 0.306 mm.

The shape of the load-elongation curves as shown in Figures 2A and 3A can give the surgeon further insight into the mechanical properties of a suture. There has been emphasis in the literature given to the “biphasic” early elastic portion of the polybutester curve. In this portion, after a very short initial rise, there is a period of rapid elongation under minimal load within the suture’s elastic region.³ This allows for initial elongation with early wound edema, but then a return to normal size once swelling settles.³ The current study confirms this phenomenon and both nylon and polybutester sutures demonstrated biphasic curves, resulting in a high initial modulus, followed quickly by lower modulus as shown in Figure 4. Overall, the highest initial modulus for the non-absorbable and absorbable sutures were found for silk sutures (8701 MPa) and rapid dissolving polyglactin 910 sutures (9320 MPa) classes, respectively.

While steps were taken to test according to USP specified conditions, it is noted that the sutures were not tested in-vivo and that values may have been different had this been possible. Further study into these suture materials to evaluate the yield point or elastic limit of these sutures as well as their responses to repeated cycles of stress could also be of value. However, overall the authors feel that the new data presented here will provide a useful baseline 1) for the practicing surgeon allowing for a more informed decision as they select their suture material and 2) for suture researchers to compare newly developed sutures in the future.

ACKNOWLEDGEMENTS

The authors would like to acknowledge Kenneth Warren III for experimental assistance. The authors gratefully acknowledge funding from the American Osteopathic College of Dermatology (A.P. Ulbrich Research Reward).

REFERENCES

1. Chu CC. Mechanical-Properties of Suture Materials - an Important Characterization. *Annals of Surgery* 1981;193(3):365-371.
2. von Fraunhofer JA, Storey RJ, Masterson BJ. Tensile Properties of Suture Materials. *Biomaterials* 1988;9(4):324-327.
3. Rodeheaver GT, Borzelleca DC, Thacker JG, Edlich RF. Unique Performance-Characteristics of Novafil. *Surgery Gynecology & Obstetrics* 1987;164(3):230-236.
4. Pineros-Fernandez A, Drake DB, Rodeheaver PA, Moody DL, Edlich RF, Rodeheaver GT. CAPROSYN*, another major advance in synthetic monofilament absorbable suture. *J Long Term Eff Med Implants* 2004;14(5):359-68.
5. Rodeheaver GT, Beltran KA, Green CW, Faulkner BC, Stiles BM, Stanimir GW, Traeland H, Fried GM, Brown HC, Edlich RF. Biomechanical and clinical performance of a new synthetic monofilament absorbable suture. *J Long Term Eff Med Implants* 1996;6(3-4):181-98.
6. Bezwada RS, Jamiolkowski DD, Lee IY, Agarwal V, Persivale J, Trenka-Benthin S, Ernetta M, Suryadevara J, Yang A, Liu S. Monocryl suture, a new ultra-pliable absorbable monofilament suture. *Biomaterials* 1995;16(15):1141-8.
7. Walton M. Strength retention of chromic gut and synthetic absorbable sutures in a nonhealing synovial wound. *Clin Orthop Relat Res* 1991(267):294-8.
8. Bourne RB, Bitar H, Andreae PR, Martin LM, Finlay JB, Marquis F. In-vivo comparison of four absorbable sutures: Vicryl, Dexon Plus, Maxon and PDS. *Can J Surg* 1988;31(1):43-5.
9. Sanz LE, Patterson JA, Kamath R, Willett G, Ahmed SW, Butterfield AB. Comparison of Maxon suture with Vicryl, chromic catgut, and PDS sutures in fascial closure in rats. *Obstet Gynecol* 1988;71(3 Pt 1):418-22.
10. Vasanathan A, Satheesh K, Hoopes W, Lucaci P, Williams K, Rapley J. Comparing suture strengths for clinical applications: a novel in vitro study. *J Periodontol* 2009;80(4):618-24.
11. Greenwald D, Shumway S, Albear P, Gottlieb L. Mechanical comparison of 10 suture materials before and after in vivo incubation. *J Surg Res* 1994;56(4):372-7.
12. Katz AR, Mukherjee DP, Kaganov AL, Gordon S. A new synthetic monofilament absorbable suture made from polytrimethylene carbonate. *Surg Gynecol Obstet* 1985;161(3):213-22.
13. Ray JA, Doddi N, Regula D, Williams JA, Melveger A. Polydioxanone (PDS), a novel monofilament synthetic absorbable suture. *Surg Gynecol Obstet* 1981;153(4):497-507.
14. Karabulut R, Sonmez K, Turkyilmaz Z, Bagbanci B, Basaklar AC, Kale N. An In Vitro and In Vivo Evaluation of Tensile Strength and Durability of Seven Suture Materials in Various pH and Different Conditions: An Experimental Study in Rats. *Indian J Surg* 2010;72(5):386-90.
15. Zaruby J, Gingras K, Taylor J, Maul D. An in vivo comparison of barbed suture devices and conventional monofilament sutures for cosmetic skin closure: biomechanical wound strength and histology. *Aesthet Surg J* 2011;31(2):232-40.
16. Schubert DC, Unger JB, Mukherjee D, Perrone JF. Mechanical performance of knots using braided and monofilament absorbable sutures. *Am J Obstet Gynecol* 2002;187(6):1438-40; discussion 1441-2.
17. <881> Tensile Strength. *United States Pharmacopeia and National Formulary (USP 29-NF 24)*. Rockville, MD: United States Pharmacopeial Convention; 2006. p 2776.

18. <861> Sutures - Diameter. United States Pharmacopeia and National Formulary (USP 29-NF 24). Rockville, MD: United States Pharmacopeial Convention; 2006. p 2775.
19. von Fraunhofer JA, Storey RS, Stone IK, Masterson BJ. Tensile-Strength of Suture Materials. *Journal of Biomedical Materials Research* 1985;19(5):595-600.
20. Absorbable Surgical Suture. United States Pharmacopeia and National Formulary (USP 29-NF 24). Rockville, MD: United States Pharmacopeial Convention; 2006. p 2050.
21. Nonabsorbable Surgical Suture. United States Pharmacopeia and National Formulary (USP 29-NF 24). Rockville, MD: United States Pharmacopeial Convention; 2006. p 2052.
22. Pillai CK, Sharma CP. Review paper: absorbable polymeric surgical sutures: chemistry, production, properties, biodegradability, and performance. *J Biomater Appl* 2010;25(4):291-366.
23. Tera H, Aberg C. Tensile strengths of twelve types of knot employed in surgery, using different suture materials. *Acta Chir Scand* 1976;142(1):1-7.
24. Fujita T. Choosing a Better Technique for Midline Abdominal Closure. *Journal of the American College of Surgeons* 2014;218(1):150-152.

Table 1: Suture materials tested in this study.

Suture	Suture Manufacturer	Lot Number	Expiration Date
<u>Non-Absorbable</u>			
Silk (Perma Hand)	Ethicon (Blue Ash, OH, USA)	GDE929 GDB645*	2018/01 2018/01*
Polypropylene (Surgipro)	Covidien (Mansfield, MA, USA)	D3C0440X	2018/03
Polybutester (Novafil)	Covidien (Mansfield, MA, USA)	D3C0268X D3D1128X*	2018/03 2018/04*
Nylon [†] (Monosof)	Ethicon (Blue Ash, OH, USA)	D2L0153X	2017/11
<u>Absorbable</u>			
Rapid Polyglactin 910 [†] (Vicryl Rapide)	Ethicon (Blue Ash, OH, USA)	GDX642 GDX499*	2018/01 2018/01*
Plain Gut (Plain Gut)	Ethicon (Blue Ash, OH, USA)	GGM177 GE6100*	2018/01 2018/01*
Chromic Gut (Chromic Gut)	Ethicon (Blue Ash, OH, USA)	EMP775	2017/07
Polyglactin 910 [†] (Vicryl)	Ethicon (Blue Ash, OH, USA)	GD2137 GE2490*	2018/01 2018/01*
Polydioxane [†] (PDS)	Ethicon (Blue Ash, OH, USA)	GA2161 GE2227*	2018/01 2018/01*
Polyglytone 6211 (Caprosyn)	Covidien (Mansfield, MA, USA)	B2J1041X	2015/09
Polyglyconate [†] (Maxon)	Covidien (Mansfield, MA, USA)	B2K1040X	2017/10
Poliglecaprone [†] (Monocryl)	Ethicon (Blue Ash, OH, USA)	GBK855 GB6954*	2018/01 2018/01*
Glycomer 631 [†] (Biosyn)	Covidien (Mansfield, MA, USA)	B3A0253X	2018/01

*Indicates lot and expiration for knot-pull tests samples if different from straight pull test samples.

[†]Indicates package was labeled as not conforming to the USP diameter standard.

Table 2: Mean and standard deviation values for diameter, failure load, failure elongation, failure stress and failure strain for each of the sutures tested in this study.

Suture	Diameter ^{1,2} (mm)	Failure Load ^{1,2} (N)	Failure Load Reduction (%)	Failure Elongation ^{1,2} (mm)	Failure Stress ^{1,2} (MPa)	Failure Strain ^{1,2}
Non-Absorbable						
Silk (SP)	0.154 (0.013)	20.7 (0.9) ^{d,e}	30.8 %	15.9 (1.0) ^a	1136.3 (175.6) ⁿ	0.262 (0.016) ^a
<i>Silk (KP)</i>	<i>0.164 (0.009)</i>	<i>14.4 (0.5)^{a,b}</i>		<i>8.9 (0.8)</i>	<i>682.2 (76.4)^{j,k}</i>	<i>0.147 (0.013)</i>
Polypropylene (SP)	0.245 (0.004)	23.2 (0.8) ^{e,f,g}	18.9 %	56.9 (6.3) ^g	493.1 (19.5) ^{e,f,g,h}	0.951 (0.104) ^g
<i>Polypropylene (KP)</i>	<i>0.247 (0.003)</i>	<i>18.9 (1.5)^{c,d}</i>		<i>38.3 (5.3)^d</i>	<i>394.8 (27.8)^{c,d,e,f}</i>	<i>0.637 (0.089)^e</i>
Polybutester (SP)	0.235 (0.003)	25.7 (0.3) ^{f,g,h}	40.0 %	59.0(2.0) ^g	595.3 (15.4) ^{h,i,j}	0.975 (0.033) ^g
<i>Polybutester (KP)</i>	<i>0.236 (0.002)</i>	<i>15.4 (1.4)^b</i>		<i>45.7 (2.9)^e</i>	<i>353.1 (32.6)^{b,c,d}</i>	<i>0.757 (0.048)^f</i>
Nylon (SP)	0.245 (0.002)	30.9 (1.0) ^j	62.1 %	59.6 (2.9) ^g	656.5 (22.1) ^{i,j,k}	0.991 (0.049) ^g
<i>Nylon (KP)</i>	<i>0.248 (0.002)</i>	<i>11.7 (0.5)^a</i>		<i>31.5 (1.4)^c</i>	<i>243.5 (10.9)^{a,b}</i>	<i>0.523 (0.022)^d</i>
Absorbable						
Rapid Polyglactin 910 (SP)	0.156 (0.006)	26.2 (0.7) ^{g,h,i}	39.0 %	25.4 (1.7) ^b	1380.1 (110.8) ^o	0.425 (0.029) ^{b,c}
<i>Rapid Polyglactin 910 (KP)</i>	<i>0.161 (0.012)</i>	<i>16.0 (1.4)^{b,c}</i>		<i>16.5 (1.4)^a</i>	<i>808.3 (177.1)^{l,m}</i>	<i>0.274 (0.023)^a</i>
Plain Gut (SP)	0.299 (0.009)	28.9 (3.8) ^{h,i,j}	40.2 %	33.2 (2.0) ^{c,d}	412.9 (58.2) ^{d,e,f,g}	0.555 (0.033) ^{d,e}
<i>Plain Gut (KP)</i>	<i>0.306 (0.003)</i>	<i>17.3 (1.6)^{b,c}</i>		<i>21.4 (3.2)^{a,b}</i>	<i>234.9 (25.6)^{a,b}</i>	<i>0.354 (0.052)^{a,b}</i>
Chromic Gut (SP)	0.302 (0.005)	29.4 (4.4) ^{i,j}	44.9 %	31.2 (3.5) ^c	410.0 (56.1) ^{d,e,f,g}	0.518 (0.058) ^{c,d}
<i>Chromic Gut (KP)</i>	<i>0.303 (0.005)</i>	<i>16.2 (1.0)^{b,c}</i>		<i>20.4 (2.5)^{a,b}</i>	<i>224.1 (15.4)^a</i>	<i>0.339 (0.041)^{a,b}</i>
Polyglactin 910 (SP)	0.189 (0.010)	38.4 (1.6) ^l	38.5 %	31.7 (1.6) ^c	1377.0 (127.3) ^o	0.530 (0.027) ^d
<i>Polyglactin 910 (KP)</i>	<i>0.167 (0.009)</i>	<i>23.6 (0.6)^{e,f,g}</i>		<i>19.7 (0.60)^a</i>	<i>1091.8 (131.8)ⁿ</i>	<i>0.326 (0.010)^a</i>
Polydioxane (SP)	0.299 (0.002)	39.3 (1.4) ^l	30.9 %	86.5 (4.9)	557.5 (16.4) ^{h,i}	1.438 (0.082)

<i>Polydioxane (KP)</i>	0.299 (0.002)	27.1 (0.7) ^{h,i}		57.0(2.1) ^g	387.6 (9.6) ^{c,d,e}	0.940 (0.034) ^g
Polyglytone 6211 (SP)	0.317 (0.003)	40.8 (1.3) ^l	44.7 %	70.9 (3.4) ^h	515.5 (10.6) ^{g,h}	1.181 (0.056) ^h
<i>Polyglytone 6211 (KP)</i>	<i>0.318 (0.001)</i>	<i>22.6 (2.1)^{e,f}</i>		<i>55.6 (4.0)^{f,g}</i>	<i>284.8 (25.9)^{a,b,c}</i>	<i>0.931 (0.067)^g</i>
Polyglyconate (SP)	0.301 (0.007)	51.6 (2.5) ^m	33.6 %	56.1 (3.9) ^g	726.3 (35.4) ^{k,l}	0.936 (0.065) ^g
<i>Polyglyconate (KP)</i>	<i>0.301 (0.004)</i>	<i>34.2 (2.8)^k</i>		<i>60.0 (1.3)^g</i>	<i>481.1 (35.5)^{e,f,g,h}</i>	<i>0.996 (0.022)^g</i>
Poliglecaprone (SP)	0.286 (0.003)	52.6 (3.4) ^m	56.7 %	68.9 (7.7) ^h	820.0 (53.4) ^{l,m}	1.144 (0.013) ^h
<i>Poliglecaprone (KP)</i>	<i>0.296 (0.002)</i>	<i>22.8 (2.0)^{e,f}</i>		<i>45.1 (3.0)^e</i>	<i>331.2 (30.0)^{a,b,c,d}</i>	<i>0.751 (0.050)^f</i>
Glycomer 631 (SP)	0.287 (0.003)	56.1 (2.2)	38.9 %	61.4 (5.3) ^g	867.6 (34.8) ^m	1.013 (0.087) ^g
<i>Glycomer 631 (KP)</i>	<i>0.292 (0.003)</i>	<i>34.3 (2.2)^k</i>		<i>50.0 (3.1)^{e,f}</i>	<i>511.6 (33.4)^{f,g,h}</i>	<i>0.825 (0.051)^f</i>

¹mean value (standard deviation)

²Straight-Pull (SP) results displayed in normal font, *Knot-Pull (KP) results displayed in italics*

Differences between mean values marked with the same lettered superscripts were not found to be statistically significant.

Table 3: Mean and standard deviation values for the initial moduli of the sutures test in this study

Suture	Initial Modulus ^{1,2} (MPa)	
Non-Absorbable		
Silk (SP)	8701.0 (1757.9) ^c	
<i>Silk (KP)</i>	5499.5 (1070.8) ^d	
Polypropylene (SP)	745.6 (26.5) ^{a,b}	
<i>Polypropylene (KP)</i>	672.0 (38.9) ^{a,b}	
Polybutester (SP)	945.3 (57.0) ^{a,b}	196.2 (16.7) ^{a *}
<i>Polybutester (KP)</i>	592.6 (126.7) ^{a,b}	186.4 (30.7) ^{a *}
Nylon (SP)	1163.9 (63.7) ^b	458.0 (15.6) ^{a,b}
<i>Nylon (KP)</i>	700.9 (199.5) ^{a,b}	383.5 (11.6) ^{a,b}
Absorbable		
Rapid Polyglactin 910 (SP)	9319.9 (1548.5) ^e	
<i>Rapid Polyglactin 910 (KP)</i>	5300.8 (655.9) ^{c,d}	
Plain Gut (SP)	706.8 (84.7) ^{a,b}	
<i>Plain Gut (KP)</i>	634.3 (64.3) ^{a,b}	
Chromic Gut (SP)	750.1 (48.5) ^{a,b}	
<i>Chromic Gut (KP)</i>	645.1 (56.1) ^{a,b}	
Polyglactin 910 (SP)	4464.0 (548.4) ^c	
<i>Polyglactin 910 (KP)</i>	4664.6 (866.9) ^{c,d}	
Polydioxane (SP)	397.8 (15.9) ^{a,b}	
<i>Polydioxane (KP)</i>	408.1 (11.0) ^{a,b}	
Polyglytone 6211 (SP)	214.9 (16.1) ^a	
<i>Polyglytone 6211 (KP)</i>	152.5 (14.1) ^a	
Polyglyconate (SP)	393.3 (47.8) ^{a,b}	
<i>Polyglyconate (KP)</i>	217.7 (18.3) ^a	
Poliglecaprone (SP)	363.4 (101.6) ^{a,b}	
<i>Poliglecaprone (KP)</i>	250.3 (20.5) ^a	
Glycomer 631 (SP)	424.5 (52.0) ^{a,b}	
<i>Glycomer 631 (KP)</i>	313.2 (20.2) ^{a,b}	

*Secondary modulus is also reported for Polybutester and Nylon.

¹mean value (standard deviation)

²Straight-pull (SP) displayed in normal font, *Knot-pull (KP) displayed in italics*

Differences between mean values marked with the same lettered superscript were not found to be statically significant.

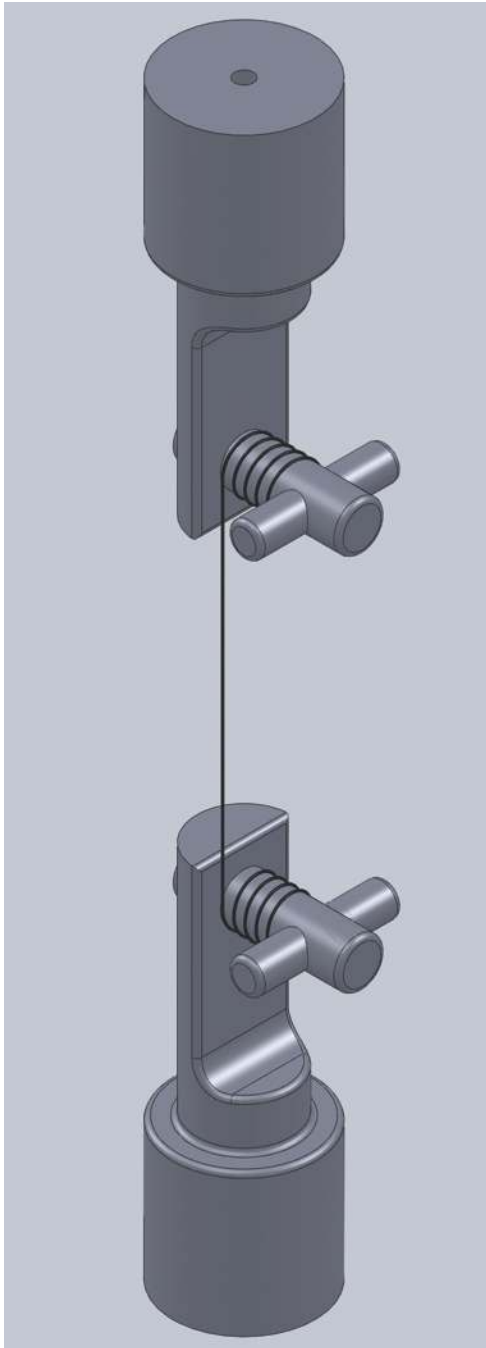

Figure 1: Solid model image of the custom tensile mounts.

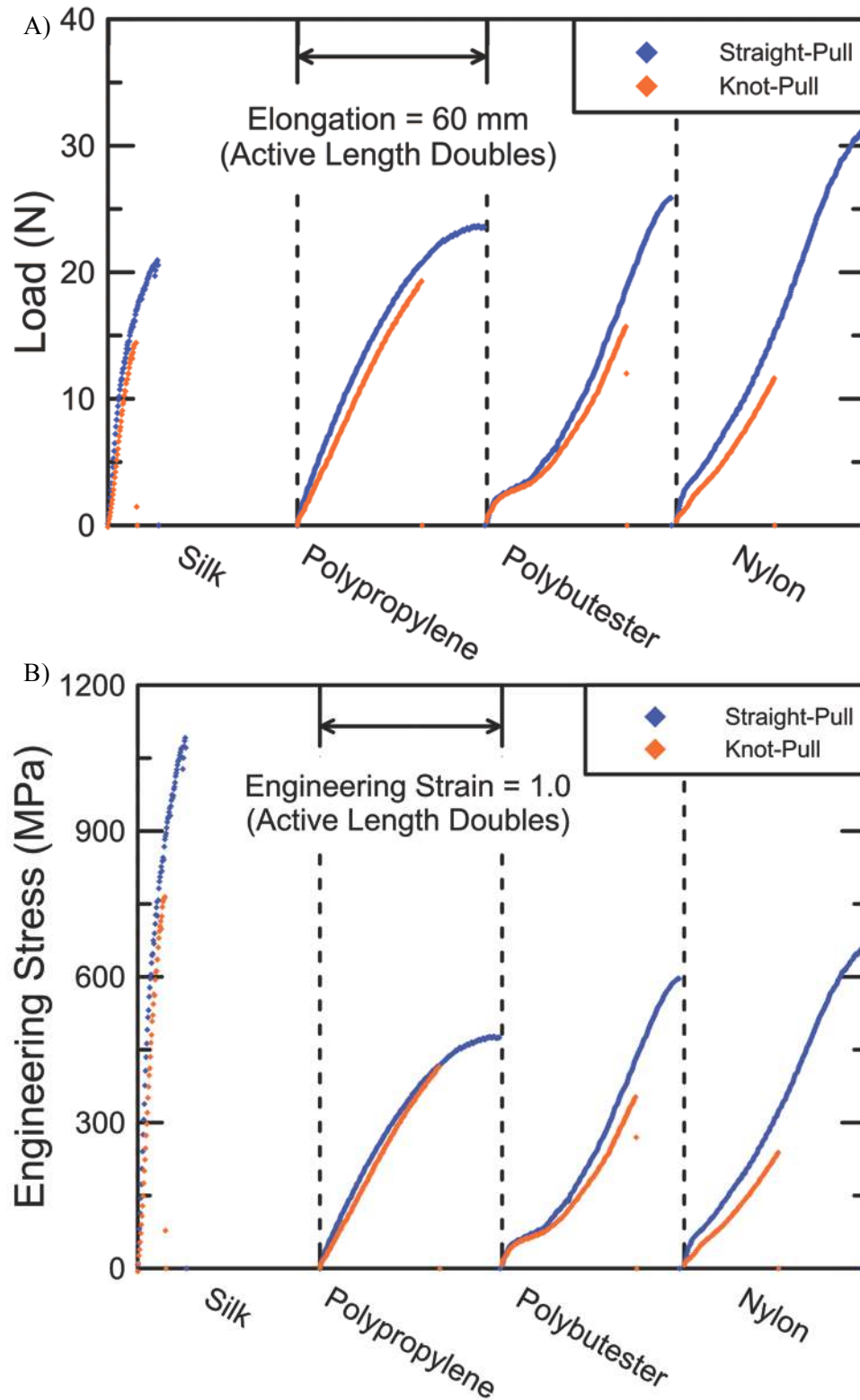

Figure 2: A) Load versus extension and B) Stress vs. strain for the non-absorbable suture materials in both the straight-pull and knot-pull configurations.

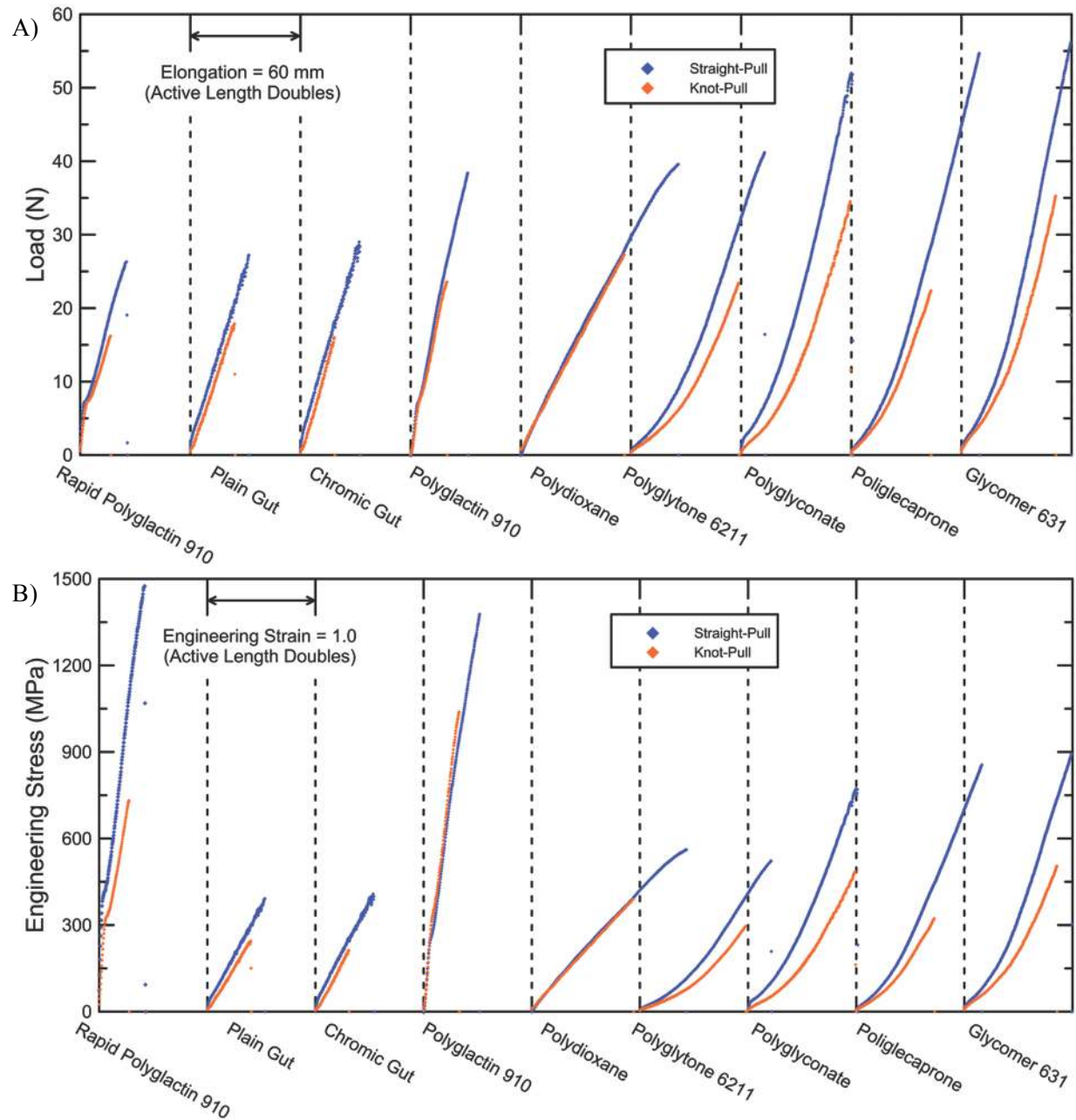

Figure 3: A) Load versus extension and B) Stress vs. strain for the absorbable suture materials in both the straight-pull and knot-pull configurations.

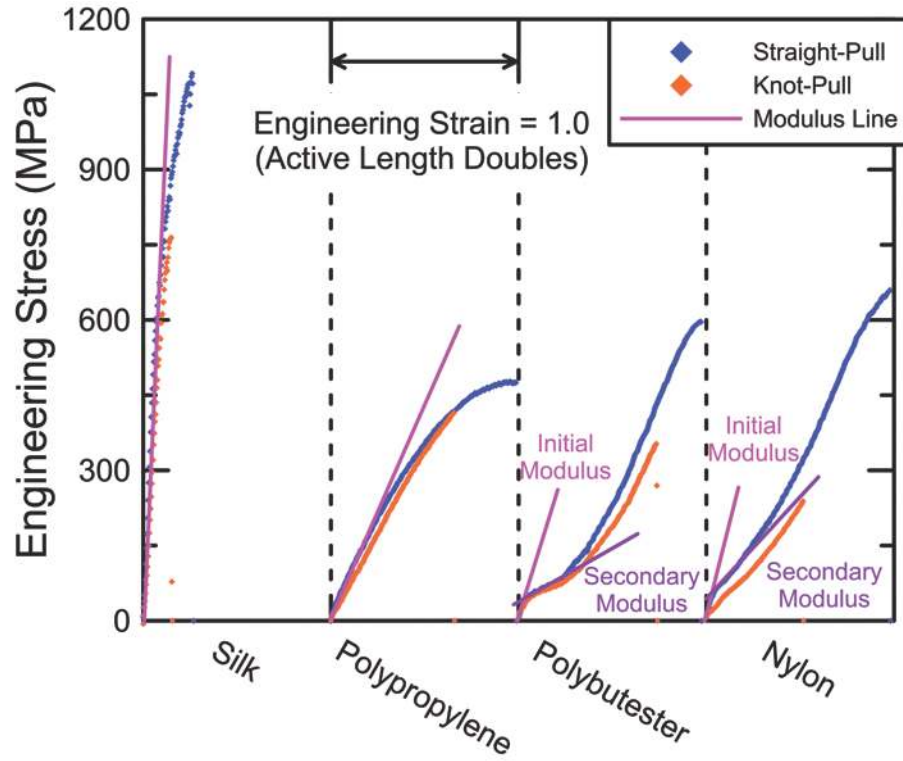

Figure 4: Modulus lines are shown which were used to determine moduli in Table 3 for the non-absorbable sutures. Note the two separate lines used for the initial and secondary moduli of the biphasic sutures.