



THE UNIVERSITY *of* EDINBURGH

Edinburgh Research Explorer

Medical sequencing of candidate genes for nonsyndromic cleft lip and palate

Citation for published version:

Vieira, AR, Avila, JR, Daack-Hirsch, S, Dragan, E, Félix, TM, Rahimov, F, Harrington, J, Schultz, RR, Watanabe, Y, Johnson, M, Fang, J, O'Brien, SE, Orioli, IM, Castilla, EE, Fitzpatrick, DR, Jiang, R, Marazita, ML & Murray, JC 2005, 'Medical sequencing of candidate genes for nonsyndromic cleft lip and palate', *PLoS Genetics*, vol. 1, no. 6, pp. e64. <https://doi.org/10.1371/journal.pgen.0010064>

Digital Object Identifier (DOI):

[10.1371/journal.pgen.0010064](https://doi.org/10.1371/journal.pgen.0010064)

Link:

[Link to publication record in Edinburgh Research Explorer](#)

Document Version:

Publisher's PDF, also known as Version of record

Published In:

PLoS Genetics

Publisher Rights Statement:

Copyright: © 2005 Vieira et al. This is an open-access article distributed under the terms of the Creative Commons Attribution License, which permits unrestricted use, distribution, and reproduction in any medium, provided the original author and source are credited.

General rights

Copyright for the publications made accessible via the Edinburgh Research Explorer is retained by the author(s) and / or other copyright owners and it is a condition of accessing these publications that users recognise and abide by the legal requirements associated with these rights.

Take down policy

The University of Edinburgh has made every reasonable effort to ensure that Edinburgh Research Explorer content complies with UK legislation. If you believe that the public display of this file breaches copyright please contact openaccess@ed.ac.uk providing details, and we will remove access to the work immediately and investigate your claim.



Medical Sequencing of Candidate Genes for Nonsyndromic Cleft Lip and Palate

Alexandre R. Vieira¹, Joseph R. Avila¹, Sandra Daack-Hirsch¹, Ecaterina Dragan¹, Têmis M. Félix¹, Fedik Rahimov², Jill Harrington¹, Rebecca R. Schultz¹, Yoriko Watanabe¹, Marla Johnson¹, Jennifer Fang¹, Sarah E. O'Brien¹, Iêda M. Orioli³, Eduardo E. Castilla^{4,5}, David R. FitzPatrick⁶, Rulang Jiang⁷, Mary L. Marazita^{8,9}, Jeffrey C. Murray^{1*}

1 Department of Pediatrics, University of Iowa, Iowa City, Iowa, United States of America, **2** Interdisciplinary Genetics PhD Program, University of Iowa, Iowa City, Iowa, United States of America, **3** Latin American Collaborative Study of Congenital Malformations, Department of Genetics, Federal University of Rio de Janeiro, Rio de Janeiro, Brazil, **4** Latin American Collaborative Study of Congenital Malformations, Department of Genetics, Fiocruz, Rio de Janeiro, Brazil, **5** Center for Medical Education and Investigation, Buenos Aires, Argentina, **6** Cell and Molecular Genetics, Medical Research Council Human Genetics Unit, Edinburgh, United Kingdom, **7** Center for Oral Biology and Department of Biomedical Genetics, University of Rochester, Rochester, New York, United States of America, **8** Center for Craniofacial and Dental Genetics, School of Dental Medicine, University of Pittsburgh, Pittsburgh, Pennsylvania, United States of America, **9** Department of Human Genetics, Graduate School of Public Health, University of Pittsburgh, Pittsburgh, Pennsylvania, United States of America

Nonsyndromic or isolated cleft lip with or without cleft palate (CL/P) occurs in wide geographic distribution with an average birth prevalence of 1/700. We used direct sequencing as an approach to study candidate genes for CL/P. We report here the results of sequencing on 20 candidate genes for clefts in 184 cases with CL/P selected with an emphasis on severity and positive family history. Genes were selected based on expression patterns, animal models, and/or role in known human clefting syndromes. For seven genes with identified coding mutations that are potentially etiologic, we performed linkage disequilibrium studies as well in 501 family triads (affected child/mother/father). The recently reported *MSX1* P147Q mutation was also studied in an additional 1,098 cleft cases. Selected missense mutations were screened in 1,064 controls from unrelated individuals on the Centre d'Étude du Polymorphisme Humain (CEPH) diversity cell line panel. Our aggregate data suggest that point mutations in these candidate genes are likely to contribute to 6% of isolated clefts, particularly those with more severe phenotypes (bilateral cleft of the lip with cleft palate). Additional cases, possibly due to microdeletions or isodisomy, were also detected and may contribute to clefts as well. Sequence analysis alone suggests that point mutations in *FOXE1*, *GLI2*, *JAG2*, *LHX8*, *MSX1*, *MSX2*, *SATB2*, *SKI*, *SPRY2*, and *TBX10* may be rare causes of isolated cleft lip with or without cleft palate, and the linkage disequilibrium data support a larger, as yet unspecified, role for variants in or near *MSX2*, *JAG2*, and *SKI*. This study also illustrates the need to test large numbers of controls to distinguish rare polymorphic variants and prioritize functional studies for rare point mutations.

Citation: Vieira AR, Avila JR, Daack-Hirsch S, Dragan E, Félix TM, et al. (2005) Medical sequencing of candidate genes for nonsyndromic cleft lip and palate. *PLoS Genet* 1(6): e64.

Introduction

Nonsyndromic or isolated cleft lip with or without palate (CL/P) occurs in wide geographic distribution with an average birth prevalence of 1/700 [1]. CL/P is a complex trait determined by multiple, interacting loci, with additional environmental covariates. Recent work suggests that three to 14 interacting loci provide a good model for genetic effects in CL/P [2].

Studying candidate genes for CL/P selected from animal models and expression patterns is a common strategy [3]. To identify gene(s) involved in CL/P, investigators have used both association and linkage approaches to evaluate genetic contributions. To detect the very small gene effects on CL/P by linkage or linkage disequilibrium strategies, sample sizes need to be large and there needs to be either a common variant in association (for linkage disequilibrium) or a substantial degree of single locus contributions (for linkage). We used direct sequencing as an alternative approach to study candidate genes for CL/P hoping to identify genes with modest effects on the disease. The results of the direct sequencing of *MSX1* [4,5] suggest that point mutations in this gene underlie approximately 2% of CL/P cases. We report here the results of sequencing 20 additional candidate genes for clefts. For seven genes with identified coding mutations that are potentially

etiologic, we performed linkage disequilibrium studies as well. For the *MSX1* P147Q mutation reported by Suzuki et al. [5], we investigated an additional 1,098 cleft cases.

Results

One hundred and forty-nine exons (representing 77,527 nucleotides of DNA sequencing), including exon-intron boundaries and untranslated regions, of 20 genes were screened for mutations in the Iowa and Philippines cleft populations. Table 2 summarizes the number of variants and

Received March 3, 2005; Accepted October 17, 2005; Published December 2, 2005
DOI: 10.1371/journal.pgen.0010064

Copyright: © 2005 Vieira et al. This is an open-access article distributed under the terms of the Creative Commons Attribution License, which permits unrestricted use, distribution, and reproduction in any medium, provided the original author and source are credited.

Abbreviations: CEPH, Centre d'Étude du Polymorphisme Humain; CL/P, cleft lip with or without cleft palate; ECLAMC, Latin American Collaborative Study of Congenital Malformations; LRT, likelihood ratio test

Editor: Veronica van Heyningen, Western General Hospital, United Kingdom

* To whom correspondence should be addressed. E-mail: jeff-murray@uiowa.edu

A previous version of this article appeared as an Early Online Release on October 17, 2005 (DOI: 10.1371/journal.pgen.0010064.eor).

Synopsis

Nonsyndromic or isolated cleft lip with or without cleft palate (CL/P) is a birth defect with wide geographic distribution, occurring with an average frequency of 1/700 live births. Treatment can be provided, but it will involve medical, surgical, dental, and psychological personnel. Several different genes have been implicated in different cases. Here the researchers report the results of sequencing 20 different genes in 184 CL/P cases selected with an emphasis on more severe cases and cases with a positive family history for CL/P. Genes were selected based on previous work done by others and by the researchers' group. The authors' results suggest that point mutations in these candidate genes are likely to contribute to about 5% of CL/P, and particularly those with more severe phenotypes (bilateral cleft of the lip with cleft palate). This study also illustrates the need to test large numbers of controls to distinguish rare polymorphic variants and allow investigators to focus functional studies on the rare point mutations that seem to be disease-causing, so that researchers might better understand the mechanisms that play a role in CL/P.

putative mutations observed. Of the 256 variants seen, 16 missense mutations in nine genes seemed to be of potential etiologic importance. All 16 missense mutations were observed in a single cleft lip and palate case, with the exception of the *SPRY2* D20A and *TBX10* R354Q mutations that were seen in two and three cases respectively. None were seen in the 186 matched controls (Table 3). These mutation sites are not highly conserved across species with the exception of the *SPRY2* and *GLI2* mutations. Both *SPRY2* mutation sites as well as three *GLI2* mutation sites are

conserved from *Xenopus* to human (Figure 1; complete data available at <http://genetics.uiowa.edu/publication/html>). The *JAG2* and the *TBX10* R354Q mutation sites are not conserved in other species orthologs available for study. The sequence surrounding the *JAG2* A657H mutation site is likely a calcium-binding EGF-like domain, which is present in a large number of membrane-bound and extracellular proteins. Also, the *SPRY2* K68N mutation site is in the sprouty domain and inhibits the Ras/mitogen-activated protein kinase (MAPK) cascade, a pathway crucial for developmental processes initiated by activation of various receptor tyrosine kinases.

All mutations were predicted to be benign by PolyPhen (<http://www.bork.embl-heidelberg.de/PolyPhen/>) with the exception of the *JAG2* M597I and *SPRY2* D20A that were "possibly damaging" and *GLI2* S1213Y that was "probably damaging" (Table 3). However, with the exception of the *LHX8* E221A, *GLI2* R426Q, and *GLI2* S1213Y mutations, all missense mutations appear to potentially disrupt splicing by either creating or inactivating exonic splicing enhancer sequences (complete information is available as supplemental material at <http://genetics.uiowa.edu/publications.html>). None of the mutations identified in this study appear to disrupt possible exonic splicing silencer sequences.

The *SATB2* T190A mutation was not found in the panel of 1064 CEPH controls as well. We also tested the *LHX8* E221A, *SKI* A388V, *SPRY2* D20A, and *TBX10* R354Q mutations in the panel of 1064 CEPH controls after not seeing it in 200 population matched controls. We found the *LHX8* E221A mutation in 17 samples, the *SKI* A388V mutation in nine samples, the *SPRY2* D20A mutation in 60 samples, and the *TBX10* R354Q mutation in six samples. (A complete list is

Table 1. Candidate Genes Studied

Gene	Map Location	KO ^a	L/LD ^b	CH ^c	Other Reason to Be Selected as Candidate	Reference
<i>FOXE1</i>	9q22	+	+	—	—	[9,28,47]
<i>GLI2</i>	2q14	—	—	—	Mutations in <i>GLI2</i> cause holoprosencephaly-like features with cleft lip and palate	[11]
<i>ISGF3G</i>	14q11.2	NA	—	—	Similar to IRF6	—
<i>JAG2</i>	14q32	+	—	—	—	[48]
<i>LHX8</i>	1p31	+	—	—	—	[49]
<i>MSX2</i>	5q34-q35	—	—	—	Similar to <i>MSX1</i>	—
<i>NAT1</i>	8p23.1–21.3	NA	+	—	Correlates with glucocorticoid-induced cleft palate in mice and is involved in smoking detoxification	[50,51]
<i>OSR2</i>	8q22.2	+	+	—	—	[28,52]
<i>P63</i>	3q27-q29	—	—	—	Mutations cause a syndromic form of clefting (ectrodactyly, ectodermal dysplasia, and orofacial clefts)	[53]
<i>PAX9</i>	14q12-q13	+	—	—	—	[54]
<i>SATB2</i>	2q32-q33	NA	+	+	—	[28,46]
<i>SKI</i>	1p36.3	+	+	+	—	[44,45]
<i>SPRY1</i>	4q28.1	NA	—	—	Sprouty expression is induced by the fibroblast growth factor receptor (FGFR) pathway. Loss-of-function mutations in <i>FGFR1</i> cause a syndromic form of clefting (Kallmann syndrome) See <i>SPRY1</i>	[35,55]
<i>SPRY2</i>	13q22.2	NA	—	—	See <i>SPRY1</i>	[35,55]
<i>TBX1</i>	22q11.21	+	—	+	Mutations cause a syndromic form of clefting (DiGeorge syndrome)	[56,57]
<i>TBX10</i>	11q13.1	NA	—	—	Ectopically expressed in Dancer cleft lip and palate mutant mice	[58]
<i>TGFA</i>	2p13	—	—	—	—	[28]
<i>TGFB1</i>	19q13.2	—	+	—	—	[28]
<i>TGFB3</i>	14q24.3	+	+	—	—	[43,59,60]
<i>TGFB1</i>	9q22	—	+	—	—	[28]

^aA plus sign (+) indicates a knockout mouse with clefts; a negative sign (–) indicates a knockout mouse without clefts.

^bA plus sign (+) indicates evidence of linkage/linkage disequilibrium; a negative sign (–) indicates no evidence of linkage/linkage disequilibrium.

^cA plus sign (+) indicates evidence of chromosome rearrangements; a negative sign (–) indicates no evidence of chromosome rearrangements.

NA, not available.

DOI: 10.1371/journal.pgen.0010064.t001

available at our Web site: <http://genetics.uiowa.edu/publications.html>).

The *MSX1* P147Q mutation was not found in any of 1,671 controls but was found in two Filipino cleft families from a panel of 1,468 cleft cases from the Philippines, which indicates a frequency of 0.14%. The first family has no family history for clefting and the variant segregates from the unaffected mother. The second family has four affected with clefts. The variant was found in two cousins and segregates from the unaffected grandmother to her unaffected son and daughter of a sibship of nine. A first cousin of the proband is affected but does not carry the variant. The last affected, a third cousin once removed, also has a cleft but does not carry the variant (Figure 2).

The *LHX8* and *SATB2* mutations were originally seen in single cases from the Philippines. For *SATB2* T190A, the variant was transmitted from the unaffected mother. The *LHX8* E221A mutation was also transmitted from the unaffected mother and is present in one affected and one unaffected person but was absent in two unaffected siblings from a sibship of eight brothers and sisters (Figure 3). Both mutation sites are conserved between human and mouse (see Appendix at <http://genetics.uiowa.edu/publications.html>). The *SKI* A388V mutation was seen in a case from Iowa. The mutation was transmitted from the mother and the mutation site is conserved between humans and species of fish and frog. Two cases from Iowa presented with the *SPRY2* D20A mutation. Of these, one had parental DNA samples available and the mutation segregated from the unaffected mother. Three cleft individuals from Iowa presented the *TBX10* R354Q mutation. In the two cases with parent samples available, one received the mutated allele from the mother and the other from the father (both unaffected).

Two additional interesting observations were made. An

Iowa case presented with isolated cleft lip with cleft palate, and no family history of clefts or any features of DiGeorge syndrome was found to be homozygous for an intronic variant in the *TBX1* gene (189 nucleotides into intron 8). This variant was not present in 186 matched controls. We tested this case for the presence of two copies of the ubiquitin fusion degradation gene (*UFDIL*), using an assay for DiGeorge or 22q syndrome [6], and the results were normal. Parental samples are not available to further study this case, nor is there enough DNA available to confirm a possible deletion by Southern blot analysis. The finding of a single rare homozygote variant suggests the possibility of a microdeletion or segmental isodisomy of this region. We tested four microsatellite markers (D22S420, D22S1685, D22S683, and D22S445) on both proband and mother samples. The mother presents distinct genotypes from the proband for D22S420 and D22S683 markers, however this finding does not exclude a segmental maternal isodisomy because the interval between these two markers, which contains *TBX1*, is 32 cM (data not shown).

The second observation involved four Filipino cases that presented a missense mutation in the last *SKI* amino acid (P728L). This mutation was not found in 186 matched controls. One case appears to have a de novo *SKI* P728L mutation. This case presented with an isolated right cleft lip and cleft palate and positive family history for clefts. Neither parent had this variant and their biological relationship to the case was confirmed after testing twenty polymorphic markers. Of the other three cases, one had a positive family history for clefts. For this case, we tested the parents, the paternal grandparents and three siblings out of a 15 sibship progeny. One of the tested siblings is affected with a right cleft lip and cleft palate associated with microcephaly. The *SKI* P728L variant segregated from the unaffected grand-

Table 2. Summary of Variants Found by Direct Sequence

Genes	Location						Frequency		Total
	Coding Variants			Non-Coding Variants			>5%	<5%	
	Syn	Non-syn	PE	Intron	5'UTR	3'UTR			
<i>FOXE1</i>	10	2	A207V, D285V	—	—	—	3	9	12
<i>GLI2</i>	3	10	R46H, R426Q, G778D, S1213Y	—	—	—	5	8	13
<i>ISGF3G</i>	4	—	—	6	—	3	3	10	13
<i>JAG2</i>	7	10	M597I, A657H	11	1	10	7	32	39
<i>LHX8</i>	1	1	E221A	2	—	1	2	3	5
<i>MSX2</i>	1	2	S63C	1	—	—	2	2	4
<i>NAT1</i>	3	7	—	—	—	—	7	3	10
<i>OSR2</i>	—	—	—	—	—	—	—	—	0
<i>P63</i>	—	—	—	17	2	—	9	10	19
<i>PAX9</i>	1	1	—	—	—	—	2	—	2
<i>SATB2</i>	—	1	T190A	3	—	—	1	3	4
<i>SKI</i>	5	4	A388V	6	—	8	6	17	23
<i>SPRY1</i>	—	—	—	—	—	3	3	—	3
<i>SPRY2</i>	—	3	D20A, K68N	—	4	—	2	5	7
<i>TBX1</i>	5	1	—	7	8	11	14	18	32
<i>TBX10</i>	—	4	R354Q	15	—	3	13	9	22
<i>TGFA</i>	2	—	—	13	2	16	10	23	33
<i>TGFB1</i>	—	2	—	2	2	—	1	5	6
<i>TGFB3</i>	1	—	—	1	4	—	3	3	6
<i>TGFBRI</i>	1	1	—	1	—	—	1	2	3

Non-syn, non-synonymous; PE, potentially etiologic; Syn, synonymous.
DOI: 10.1371/journal.pgen.0010064.t002

Table 3. Potential Mutations Found in the Present Study

Population (Number of Affected Individuals)	Gene	Amino Acid Change	PolyPhen Prediction	Phenotype		FH	Parents' Genotypes	
				Clefts	Other ^a		Father	Mother
Philippines (1/91)	<i>FOXE1</i>	A207V	Benign	BL CL/P	—	Yes	207AV	207AA
Iowa (1/93)	<i>FOXE1</i>	D285V	Benign	BL CL/P	—	Yes	285DD	285DV
Iowa (1/93)	<i>GLI2</i>	R46H	Benign	R CL/P	—	No	46RR	46RH
Philippines (1/91)	<i>GLI2</i>	R426Q	Benign	BL CL/P	1	Yes	NA	NA
Iowa (1/93)	<i>GLI2</i>	G778D	Benign	R CL/P	—	No	NA	NA
Philippines (1/91)	<i>GLI2</i>	S1213Y	Probably damaging	BL CL/P	—	Yes	NA	NA
Philippines (1/91)	<i>LHX8</i>	E221A ^b	Benign	BL CL/P	—	Yes	221EE	221EA
Iowa (1/93)	<i>JAG2</i>	M597I	Possibly damaging	BL CL/P	—	No	NA	NA
Philippines (1/91)	<i>JAG2</i>	A657H	Benign	BL CL/P	—	Yes	657AA	NA
Iowa (1/93)	<i>MSX2</i>	S63C	Benign	L CL/P	2	No	NA	NA
Philippines (1/91)	<i>SATB2</i>	T190A ^c	Benign	BL CL/P	—	No	190TT	190TA
Iowa (1/93)	<i>SKI</i>	A388V ^b	Benign	L CL/P	—	No	388AA	388AV
Iowa (2/93)	<i>SPRY2</i>	D20A	Possibly damaging	R CL/P	—	Yes	NA	NA
				L CL/P	—	No	20DD	20DA
Iowa (1/93)	<i>SPRY2</i>	K68N	Benign	L CL/P	—	No	NA	NA
Iowa (3/93)	<i>TBX10</i>	R354Q ^b	Benign	NA	NA	NA	NA	NA
				L CL/P	—	Yes	354RR	354RQ
				Unknown CL/P	3	No	354RQ	354RR
Philippines (2/1098)	<i>MSX1</i>	P147Q	Benign	R CL/P	—	Yes	147PQ	147PP
				BL CL/P	4	No	147PP	147PQ

The mutations in this table were not found in 186 matched controls. None of the cases presented an affected parent.

^a1 indicates polydactyly; 2 indicates epicanthal folds; 3 indicates café au lait spots; 4 indicates hypertelorism.

^bMutations not found in 186 controls but disclosed when an extended control set of 1,064 samples were studied.

^cMutations not found in the extended control set of 1,064 samples.

BL CL/P, bilateral cleft lip with cleft palate; FH, family history for clefts; L CL/P, unilateral left cleft lip with cleft palate; NA, information not available, sample not available, or sequencing failed; R CL/P, unilateral right cleft lip with cleft palate.
DOI: 10.1371/journal.pgen.0010064.t003

father to the unaffected father. Of the three siblings tested, the two unaffected siblings had the variant, but the affected sibling did not. Based on this family, we concluded that this *SKI* P728L variant is probably not an etiologic mutation and included it in the column of non-synonymous coding variants in Table 2.

Linkage disequilibrium studies were performed for the genes *GLI2*, *JAG2*, *MSX2*, *SATB2*, *SKI*, *SPRY2*, and *TBX10* in which likely etiologic missense mutations had been observed (complete information is available as supplemental material at <http://genetics.uiowa.edu/publications.html>; results for *FOXE1* were previously reported in Marazita et al. [7]). No single nucleotide polymorphism tested showed evidence for deviation from Hardy-Weinberg equilibrium in either the affected or unaffected individuals (data not shown). The haplotype analysis using the HBAT function of FBAT (<http://www.biostat.harvard.edu/~fbat/fbat.htm>) demonstrated borderline associations between *MSX2* in both Filipino ($p = 0.001$) and Iowa ($p = 0.008$) populations, between *JAG2* and the Filipinos ($p = 0.004$), and between both *SATB2* ($p = 0.03$) and *TBX10* ($p = 0.04$) and the Iowa population. However, when we combined the *MSX2* haplotype data for both Filipino and Iowa populations, the association was weaker ($p = 0.09$). We also observed an association between CL/P and snp2 (rs2843159) in *SKI* ($p = 0.000004$) in the Filipino population. This association between CL/P and *SKI* in Filipinos was also suggested by the haplotype analysis ($p = 0.0002$). In addition, the same *SKI* snp2 marker showed association with cleft lip only in the South American clefting population from the Latin American Collaborative Study of Congenital Malformations (ECLAMC) ($p = 0.004$).

Discussion

Point mutations in the candidate genes *FOXE1*, *GLI2*, *MSX2*, *SKI*, *SATB2*, and *SPRY2* appear in aggregate to contribute to as much as 6% of isolated cleft lip and palate cases, enriched for cases with bilateral cleft of the lip with cleft palate and a positive family history. The mutations found in this study are conserved in other mammals, may disrupt exonic splicing enhancer sequences, and were not found in between 400 to 2,000 control chromosomes. The *JAG2* M597I and A657H mutations, although they appear to disrupt exonic splicing enhancer sequences and possibly damage the *JAG2* protein, according to the PolyPhen prediction, are not conserved in other species and may be rare polymorphic sites.

Testing a larger number of control samples proved to be a useful way to differentiate rare polymorphisms from etiologic mutations. The *LHX8* E221A, *SATB2* T190A, *SKI* A388V, *SPRY2* D20A, and *TBX10* R354Q variants initially were not observed in approximately 200 matched controls. This number of controls is commonly used to assume that if a variant is not present, it is likely causal despite models that have shown that a larger number of controls is useful in eliminating rare variants [8]. However, when we tested these variants in the extended set of 1,064 controls, we found the *LHX8* E221A variant in 17 individuals, the *SKI* A388V mutation in nine, the *SPRY2* D20A mutation in 60 individuals, and the *TBX10* R354Q in six individuals. Although the presence of the amino acid changes in unaffected controls does not exclude them from playing a role in CL/P, it does place them in a lower priority group for additional functional

A

GLI2 aa1201-aa1223

S1213Y

Homo sapiens	L S P S L L H S L S Q N S S R L T T P R N S L
Mus musculus	L S P T L L H N L S Q N S S R L T T P R N S L
Xenopus laevis	L S P G L L H S F S Q T S S R L T T P R N S L
Danio rerio	L S P G L L Q S I S Q N S S R L T T P R N S V



B

SPRY2 aa1-aa30

D20A

Home sapiens	M E A R A Q S G - N G S Q P L L Q T P R D G G R - Q R G E P D P
Mus musculus	M E A R A Q S G - N G S Q P L L Q T A H D S G R - Q R G E P D P
Rattus norvegicus	M E A R A Q S G - N G S Q P L L Q S P H D S G R - Q R G E P D P
Gallus gallus	M E T R V Q H G - S G S Q A L L Q A R R D S G R - P H G E P D L
Xenopus laevis	M E T R V Q N G - N V S Q P L L P A R R D N G R - L H S D T D P
Danio rerio	M E T R T Q N G G S G S S G L L R A L R D S G R P Q T G D S E P

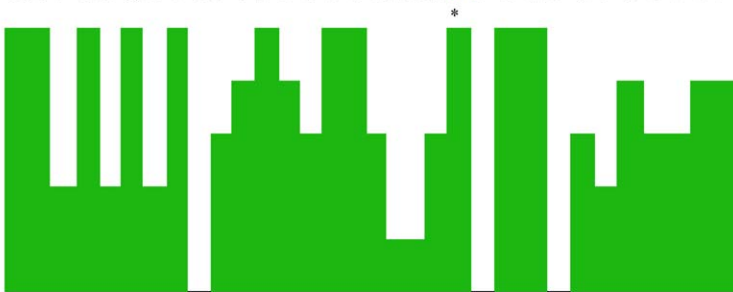

Figure 1. Protein Comparisons of the Available Gene Orthologs for GLI2 S1213Y and SPRY2 D20A

GLI2 S1213Y (A) and SPRY2 D20A (B): Green bars indicate degree of conservation in each site. Amino acids in red indicate the mutation sites. All mutation comparisons are available as supplemental material at <http://genetics.uiowa.edu/publications.html>.

DOI: 10.1371/journal.pgen.0010064.g001

analysis and makes them difficult to use in any applied genetic counseling setting as they may be, at best, modifiers with low penetrance contributory alleles.

Some variants, such as the *SKI* A388V mutation, which is conserved back to *Xenopus* and *Tilapia* but is found in controls, demonstrate that species conservation alone maybe not enough to argue for an etiologic role of a given variant.

Our study illustrates the difficulties of defining as causal a mutation rarely seen in the population. Many of the missense mutations found in the cases studied were seen only when we extended our screen to a larger control group comprised of samples from ethnically diverse groups from almost all parts of the world. In addition, none of the mutations segregated from an affected parent. Incomplete penetrance is likely the explanation for the mutations that may be causal as has been clearly shown for other genes that contribute to clefting such as *MSX1* [9] and *FGFR1* [10] mutations. It is likely that we found these mutations only because we tested cases more likely to present a stronger genetic contribution (cases with

positive family history and bilateral cleft of the lip with cleft palate). Mutations like the *MSX1* P147Q and others that appear to show incomplete penetrance are comparable to autosomal dominant disorders resulting from mutations in *SCN5A* [11], *IRF6* [12], or *NKX2.5* [13].

The *MSX1* P147Q mutation was seen in two cleft cases from the Philippines, but in none of the over 1,600 controls. It appears that this specific mutation underlies approximately 0.15% cases of apparent isolated CL/P. As shown previously this variant results in variable expression and decreased penetrance that make prospective studies of its phenotypic outcome necessary before accurate genetic counseling risk can be measured [5].

Rigorous demonstration that a mutation disrupts a genuine exonic splicing enhancer requires that the sequence autonomously promote splicing and that enhancement be absent in the mutant. An advantage of the score matrix approach [14] is that it allows direct testing of predicted effects on individual putative enhancer sites, rather than having to characterize exonic splicing enhancers by testing multiple random

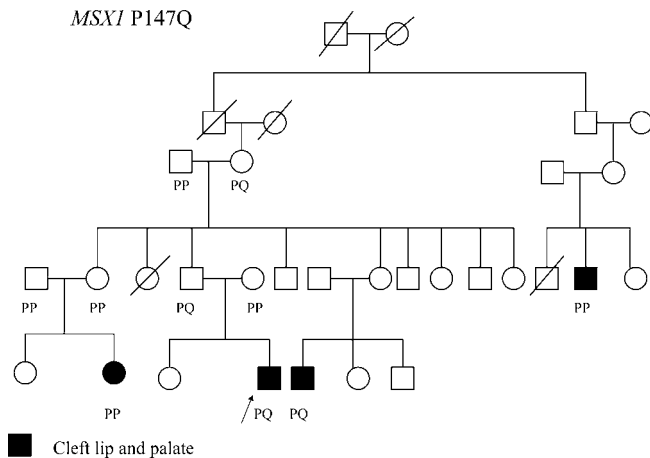

Figure 2. Family Pedigree of the Filipino Family Segregating the *MSXI* P147Q Mutation

PP (proline–proline) indicates the wild-type genotype. PQ (proline–glutamine) indicates the genotype of the individuals carrying the mutation.

DOI: 10.1371/journal.pgen.0010064.g002

mutations and/or deletions along an exon. All 15 mutations on Table S2 appear to inactivate and/or create a predicted exonic splicing enhancer of at least one of the four serine/arginine-rich (SR) proteins. However, the presence of a high-score motif in a sequence does not necessarily identify that sequence as an exonic splicing enhancer in its native context.

In *TBX1*, we found one rare intronic variant in homozygous form in an Iowa cleft case, which could indicate that clefts arise from recessive functional intronic mutations in *TBX1*, or microdeletions that cannot be visualized by direct sequencing. This case does not have a 22q deletion involving the *UFDIL* gene. Detecting this rare homozygote in the absence of this variant in any other of the 400 people tested suggests these individuals may be identical by descent at this locus and gene. This variant itself, or others in linkage disequilibrium in *TBX1*, might be a hypomorphic allele whose joint presence results in enough change in gene expression or function to trigger a phenotype. Therefore, other alleles in regulatory regions of *TBX1* should be a priority for identification.

Previous work from our group has screened *FGFR1*, *IRF6*, *MSXI*, *TGFA*, and *TGFB3* for mutations on cleft cases. Point mutations in *MSXI* appear to contribute approximately to 2% of all CL/P cases [4]. *FGFR1* point mutations also appear to contribute to CL/P. In addition, *FGFR1* loss-of-function mutations can cause forms of Kallmann syndrome that mimic isolated CL/P at birth and during childhood. Mutations in *IRF6*, which cause the syndromic forms of clefts, the Van der Woude and popliteal pterygium syndromes [12], were not found in the same collection of cleft cases as the present study, although rare non-coding variants in conserved regions were disclosed. However, *IRF6* is strongly associated with CL/P, and it is likely a genetic modifier for clefts [15,16]. Previously for *TGFA*, five variants in conserved non-coding segments were found in individual cases but not seen in 278 controls [17]. In the present study we found another nine non-coding rare variants in single individuals, but we did not find the original five reported rare variants or any coding mutation that could be etiologic. If these variants are disease-causing mutations, they could explain, not only the conflict-

LHX8 E221A

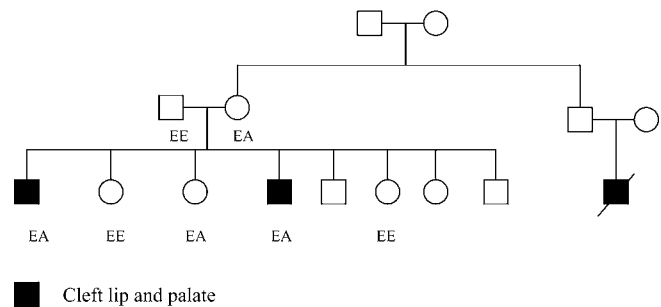

Figure 3. Family Pedigree of the Filipino Proband with the *LHX8* E221A Mutation

The segregation pattern of the mutation is not consistent with a simple Mendelian model for the disease.

EE (glutamic acid–glutamic acid) indicates the wild-type genotype. EA (glutamic acid–alanine) indicates the genotype of the individuals carrying the mutation.

DOI: 10.1371/journal.pgen.0010064.g003

ing results from association studies of isolated orofacial clefts and *TGFA* variants [18], but also the linkage studies that suggest a cleft susceptibility loci in 2p13, the *TGFA* locus [7]. For *TGFB3*, we previously reported one missense mutation (K130R) in a cleft palate-only case not seen in 350 controls [19]. We did not find this or any other mutations in *TGFB3* in our current study population.

Loss-of-function mutations in *GLI2* are associated with pituitary anomalies and holoprosencephaly-like features [20]. In this report, the three pedigrees segregating *GLI2* loss-of-function mutations with complete clinical information presented orofacial clefts and polydactyly. We found four missense mutations in *GLI2* in highly conserved amino acids. One of the cases also presented with polydactyly (Table 3).

We performed linkage disequilibrium studies in the genes that we found potentially disease-causing missense mutations. We found association between a marker (rs2843159) and a haplotype in *SKI* in the Filipino population. This association was also found in an independent population dataset from South America. The *SKI* locus, 1p36.3, was previously suggested as a cleft susceptibility loci in Caucasians [21,22]. *Ski* null mice present with clefts involving the lip [22], and the association we found appears to be stronger when cases with the involvement of the lip are included.

The possible trend for an association between clefts with a palate phenotype and *SATB2* are in agreement with the cytogenetic evidence. Deletions and balanced translocations point to the existence of a locus on 2q32–q33, for which haploinsufficiency results in isolated cleft palate. A mutation analysis of *SATB2* (located at 2q32–q33) in 70 unrelated patients with isolated cleft palate only did not reveal any coding region variants [23]. However, a meta-analysis of 13 genome scans for clefts indicated 2q32–q35 as a clefting susceptibility locus [7]. We studied 184 cleft lip and palate cases and found one missense mutation in *SATB2* (T190A) that was not seen in approximately 1,200 controls. Based on the linkage disequilibrium and mutation analysis results of our study, we believe a regulatory element outside *SATB2* coding regions may be implicated in clefting.

In summary, point mutations in six of the 20 candidate genes selected from expression, animal, and human data may contribute to about 5% of isolated clefts, more likely those with more-severe phenotypes and/or a positive family history. Etiologic variants in regulatory elements of *SKI*, *JAG2*, and *MSX2* may contribute to isolated clefts as well. Predictions by ESEfinder (<http://rulai.cshl.edu/tools/ESE/>) and PolyPhen regarding the function of the missense mutations found in this study, as well as exonic splicing enhancement and protein damaging, are challenging to interpret.

A major challenge in these studies was the frequent absence of a cleft phenotype in near relatives of an affected proband with a cleft and a rare missense mutation. In some cases these variants may not be etiologic, but in others, reduced penetrance for the cleft may be an active force as has been seen commonly in clefts [9,10] and other birth defects such as congenital heart disease. Similarly these mutations may only be modifiers of the phenotype.

Cases due to microdeletions or isodisomy may contribute to clefts as well. This study illustrates the validity of testing greater numbers of controls to determine rare polymorphic variants and prioritize functional studies for rare point mutations. Given other recent data on the roles of *FGFR1*, *IRF6*, and *MSX1* in isolated CL/P, one can begin to consider sequencing of a panel of high-probability candidate genes for genetic counseling indication. Although issues of penetrance and even etiology for any given mutation are not yet resolved, progress in this direction is now measurable.

Materials and Methods

Two collections of CL/P cases, 91 from the Philippines and 93 from Iowa, United States, were used to search for mutations in 20 candidate genes (Table 1). We selected the more-severe cases from those available to us, and the sequenced samples were enriched by bilateral cleft lip and palate cases with a positive family history for clefts (39/91 from the Philippines and 16/93 from Iowa). Two cases were later found to have associated features—one with Stickler syndrome in which family history was initially not available, and a second with polydactyly. Cases from the Philippines were studied under the auspices of Operation Smile International [24]. Patients were seen and examined by a board certified clinical geneticist (JCM or colleagues; see Acknowledgments) at one of four sites within the Philippines (Cavite, Kalibo, Cebu, and Negros). Iowa cases were collected through the Iowa Birth Defects Registry [25]. Signed consents were obtained from all participants before a blood sample was obtained. DNA was extracted according to published protocols.

For each of the 20 candidate genes, all exons and 5' and 3' untranslated regions were sequenced in both directions. Primer sequences and PCR conditions are available on our Web site (<http://genetics.uiowa.edu/publications.html>). Primers for *FOXE1*, *GLI2*, *MSX2*, *OSR2*, and *TGFBR1* were obtained from the literature [20,26–29]. Cycle sequencing was performed in a 20- μ l reaction using 4 μ l of Applied Biosystems Big Dye Terminator sequencing reagent, 1 μ l of 5 μ M sequencing primer, 1 μ l of DMSO, 4 μ l of 2.5 \times Buffer, and 2.5 ng/100 base pair of DNA template. Following a denaturation step at 96 $^{\circ}$ C for 30 s, reactions were cycle sequenced at 96 $^{\circ}$ C for 10 s, 50 $^{\circ}$ C for 5 s, and 60 $^{\circ}$ C for 4 min for 40 cycles. Cleanup was performed using standard protocols. Samples were resuspended in 40 to 100 μ l of ddH₂O, and 2.5 μ l were then injected on an Applied Biosystems 3700 sequencer. The Applied Biosystems sequence software (version 2.1.2) was used for lane tracking and first pass base calling. Chromatograms were transferred to a Unix workstation, base called with PHRED (version 0.961028), assembled with PHRAP (version 0.960731), scanned by POLYPHRED (version 0.970312), and the results viewed with CONSED (version 4.0) [30]. When the results indicated a possible new variant, the case sample was resequenced, as well as other available family members, and population controls. These data were analyzed using the same method.

For any coding variant, we performed direct sequencing in 186 population-matched controls. Control populations were collected as described above for the cases and consisted of individuals with no CL/P or other recognized birth defect from adults at the same sites where cases were collected. If the variant was found in one or more controls, it was considered a polymorphism. To expand the number of controls tested, we developed allele-specific assays for the *LHX8* E221A, *SATB2* T190A, *SKI* A388V, *SPRY2* D20A, and *TBX10* R354Q mutations. We tested them in the CEPH Diversity Cell Line Panel [31], which is comprised of 1,064 DNA samples from cultured lymphoblastoid cell lines derived from individuals representing 51 different human populations.

We also developed an assay for the *MSX1* P147Q missense mutation, recently reported in three Vietnamese cleft families [5]. Besides the 1,064 CEPH Diversity Cell Line Panel controls, we tested the *MSX1* P147Q assay in an additional 607 Filipino controls and in a collection of 1,468 cleft cases from the Philippines as well.

For the nine genes with potentially etiologic missense mutations, we identified orthologs through BLAST search of the non-redundant database using *Homo sapiens* *FOXE1*, *GLI2*, *LHX8*, *JAG2*, *MSX2*, *SATB2*, *SKI*, *SPRY2*, and *TBX10*, as reference sequences. We performed protein sequence comparisons with the available species. We also used the ESEfinder software available online to predict the presence of exonic splicing enhancers [14], which appear to be prevalent, and may be present in most, if not all exons [32,33]. We screened the 141 exonic splicing silencer decamers that were identified by Wang et al. [34] to check if any of those could be affected by the missense mutations we found. Finally, we used the PolyPhen software, also available online, to predict the impact of the amino acid substitutions identified on the structure and function of the human protein [35–37].

Two single nucleotide polymorphisms in weak linkage disequilibrium with each other were selected for each population to perform linkage disequilibrium studies in the genes with missense mutations in cases but not in controls. Four single nucleotide polymorphisms were chosen for *GLI2* based on the International HapMap Project's linkage disequilibrium pattern of the gene (data not shown). Frequency of the alleles can be found in the supplemental material (<http://genetics.uiowa.edu/publications.html>). TaqMan-based assays [38] were performed on Applied Biosystems 7900 HT Sequence Detection System (Applied Biosystems, Foster City, California, United States). For one marker in *SKI* (rs2843159), we used a kinetic polymerase chain reaction assay previously reported [39]. These linkage disequilibrium studies were composed of 296 complete triads (mother/father/affected child) from the Philippines and 205 from Iowa. These samples were obtained as described above for cases and controls investigated by sequencing. The Family Based Association Test (FBAT) [40–42] program was used for this analysis. Significance figures were accounted for using Bonferroni correction taking into account the number of tests carried out [43]. With the Bonferroni correction, alpha is 0.0003 (0.05/192 comparisons) for the individual marker analysis and 0.0001 (0.05/384 comparisons) for the haplotype analysis. Linkage disequilibrium studies for *FOXE1* were previously reported in Marazita et al. [7].

A third clefting population sample set of 434 case/mother pairs from South America was used to replicate any significant association. These population samples are derived from ECLAMC, which is a hospital-based birth defects registry study that includes sites in Argentina, Bolivia, Brazil, Chile, Ecuador, Paraguay, Uruguay, and Venezuela. This study population has previously been described in detail [44,45]. To analyze the ECLAMC samples, the likelihood ratio test (LRT) of Weinberg [46] was applied under the assumption that the distribution of paternal alleles is the same as maternal.

Supporting Information

Figure S1. Protein Comparisons of the Available Gene Orthologs for the Mutations Found in the Present Study

Green bars indicate degree of conservation in each site. Amino acids in red indicate the mutation sites. All mutation comparisons are available as supplemental material at <http://genetics.uiowa.edu/publications.html>.

Found at DOI: 10.1371/journal.pgen.0010064.sg001 (56 KB PDF).

Table S1. Primers and PCR Conditions

Found at DOI: 10.1371/journal.pgen.0010064.st001 (51 KB PDF).

Table S2. Exonic Splicing Enhancer Prediction Analysis for the

Missense Mutations Found in the Present Study. Nucleotides in red indicate the mutation sites.

Found at DOI: 10.1371/journal.pgen.0010064.st002 (61 KB PDF).

Table S3. Mutations Screened in the CEPH Diversity Cell Line Panel

Found at DOI: 10.1371/journal.pgen.0010064.st003 (48 KB PDF).

Table S4. Markers Selected for Linkage Disequilibrium Studies

Found at DOI: 10.1371/journal.pgen.0010064.st004 (49 KB PDF).

Table S5. Haplotype Frequencies

Found at DOI: 10.1371/journal.pgen.0010064.st005 (46 KB PDF).

Table S6. Linkage Disequilibrium Studies of Candidate Genes for Clefting

Found at DOI: 10.1371/journal.pgen.0010064.st006 (50 KB PDF).

Table S7. Haplotype Analysis

Found at DOI: 10.1371/journal.pgen.0010064.st007 (54 KB PDF).

Table S8. SKI LRT Results for the South American (ECLAMC) Clefting Samples

Found at DOI: 10.1371/journal.pgen.0010064.st008 (40 KB PDF).

Accession Numbers

The National Center for Biotechnology Information (<http://www.ncbi.nlm.nih.gov/>) Unigene accession numbers for the genes discussed in this paper are *Homo sapiens* *FOXE1* (NM_004473), *GLI2* (NP_084655), *JAG2* (NM_002226), *LHX8* (AY449521), *MSX2*

(NM_002449), *SATB2* (NM_015265), *SKI* (AY334556), *SPRY2* (NM_005842), and *TBX10* (AY229977).

Acknowledgments

We are indebted to all the families that participated in this project. Buena Nepomucena and Paul Romitti supported the sample collection. Diana Caprau provided sample management. Carla Nishimura, Sally Santiago, John Allaman, Bonnie Ludwig, Kristin Aquilino, Kristin Orr, Amy Mach, and Darren Schipper provided technical support. Clinical exams in the Philippines were carried out on some cases by Howard Saal and Chinto Fong. Nasir Malik and Heiner Westphal assisted with the *LHX8* studies. Maurice Payne completed preliminary work on *ISGF3G*. Marianne Timm and Renata Lucia Ferreira de Lima did preliminary work on *JAG2*. Mark Kresowik did preliminary work on *MSX2* and *TBX1*. Elliott Hill helped with *TGFB3* sequencing. Satoshi Suzuki assisted with the *MSX1* P147Q assay. Margaret Cooper helped with the LRT analysis. Financial support was provided by National Institutes of Health grants DE08559, DE16215, ES10876, and 5 D43 TW05503.

Competing interests. The authors have declared that no competing interests exist.

Author contributions. ARV, IMO, EEC, and JCM conceived and designed the experiments. ARV, JRA, ED, TMF, FR, JH, RRS, YW, MJ, JF, and SEO performed the experiments. ARV, JRA, SDH, ED, TMF, FR, JH, RRS, YW, MJ, JF, SEO, IMO, EEC, DRF, RJ, MLM, and JCM analyzed the data. SDH, DRF, RJ, MLM, and JCM contributed reagents/materials/analysis tools. ARV and JCM wrote the paper. ■

References

- Mossey PA, Little J (2002) Epidemiology of oral clefts: An international perspective. In: Wyszynski DF, editor. Cleft lip and palate. From origin to treatment. New York: Oxford Press, pp. 127–158.
- Schliekelman P, Slatkin M (2002) Multiplex relative risk and estimation of the number of loci underlying an inherited disease. *Am J Hum Genet* 71: 1369–1385.
- Murray JC, Schutte BC (2004) Cleft palate: Players, pathways, and pursuits. *J Clin Invest* 113: 1676–1678.
- Jezewski PA, Vieira AR, Nishimura C, Ludwig B, Johnson M, et al. (2003) Complete sequencing shows a role for *MSX1* in non-syndromic cleft lip and palate. *J Med Genet* 40: 399–407.
- Suzuki Y, Jezewski PA, Machida J, Watanabe Y, Shi M, et al. (2004) In a Vietnamese population, *MSX1* variants contribute to cleft lip and palate. *Genet Med* 6: 117–125.
- Kariyazono H, Ohno T, Ihara K, Igarashi H, Joh-o K, et al. (2001) Rapid detection of the 22q11.2 deletion with quantitative real-time PCR. *Mol Cellular Probes* 15: 71–73.
- Marazita ML, Murray JC, Lidral AC, Arcos-Burgos M, Cooper ME, et al. (2004) Meta-analysis of 13 genome scans reveals multiple cleft lip/palate genes with novel loci on 9q21 and 2p32–35. *Am J Hum Genet* 75: 161–173.
- Collins JS, Schwartz CE (2002) Detecting polymorphisms and mutations in candidate genes. *Am J Hum Genet* 71: 1251–1252.
- van den Boogard MJH, Dorland M, Beemer FA, van Amstel HKP (2000) *MSX1* mutation is associated with orofacial clefting and tooth agenesis in humans. *Nat Genet* 24: 342–343.
- Dodé C, Levilliers J, Dupont JM, De Paepe A, Le Dû N, et al. (2003) Loss-of-function mutations in *FGFR1* cause autosomal dominant Kallmann syndrome. *Nat Genet* 33: 463–465.
- Hong K, Brugada J, Oliva A, Berruero-Sanchez A, Potenza D, et al. (2004) Value of electrocardiographic parameters and ajmaline test in the diagnosis of Brugada syndrome caused by *SCN5A* mutations. *Circulation* 110: 3023–3027.
- Kondo S, Schutte BC, Richardson RJ, Bjork BC, Knight AS, et al. (2002) Mutations in interferon regulatory factor 6 cause Van der Woude and popliteal pterygium syndromes. *Nat Genet* 32: 285–289.
- Watanabe Y, Benson DW, Yano S, Akagi T, Yoshino M, et al. (2002) Two novel frameshift mutations in *NKX2.5* result in novel features including visceral inversus and sinus venosus type ASD. *J Med Genet* 39: 807–811.
- Cartegni L, Wang J, Zhu Z, Zhang MQ, Krainer AR (2003) ESEfinder: A web resource to identify exonic splicing enhancers. *Nucleic Acid Res* 31: 3568–3571.
- Zuccherro T, Cooper ME, Maher BS, Daack-Hirsch S, Nepomuceno B, et al. (2004) Interferon regulatory factor (IRF6) is a modifier for isolated cleft lip and palate. *New Engl J Med* 351: 769–780.
- Scapoli L, Palmieri A, Martinelli M, Pezetti F, Carinci P, et al. (2005) Strong evidence of linkage disequilibrium between polymorphisms at the *IRF6* locus and nonsyndromic cleft lip with or without cleft palate, in an Italian population. *Am J Hum Genet* 76: 180–183.
- Machida J, Yoshiura K, Funkhauser CD, Natsume N, Kawai T, et al. (1999) Transforming growth factor- α (TGFA): Genomic structure, boundary sequences, and mutation analysis in nonsyndromic cleft lip/palate and cleft palate only. *Genomics* 61: 237–242.
- Mitchell LE (1997) Transforming growth factor α locus and nonsyndromic cleft lip with or without cleft palate: A reappraisal. *Genet Epidemiol* 14: 231–240.
- Lidral AC, Romitti PA, Basart AM, Doetschman T, Leysens NJ, et al. (1998) Association of *MSX1* and *TGFB3* with nonsyndromic clefting in humans. *Am J Hum Genet* 63: 557–568.
- Roessler E, Du YZ, Mullor JL, Casas E, Allen WP, et al. (2003) Loss-of-function mutations in the human *GLI2* gene are associated with pituitary anomalies and holoprosencephaly-like features. *Proc Natl Acad Sci U S A* 100: 13424–13429.
- Prescott NJ, Lees MM, Winter RM, Malcolm S (2000) Identification of susceptibility loci for nonsyndromic cleft lip with or without cleft palate in a two stage genome scan of affected sib-pairs. *Hum Genet* 106: 345–350.
- Colmenares C, Heilstedt HA, Shaffer LG, Schwartz S, Berk M, et al. (2002) Loss of the *SKI* proto-oncogene in individuals affected with 1p36 deletion syndrome is predicted by strain-dependent defects in *Ski*^{-/-} mice. *Nat Genet* 30: 106–109.
- FitzPatrick DR, Carr IM, McLaren L, Leek JP, Wightman P, et al. (2003) Identification of *SATB2* as the cleft palate gene on 2q32–q33. *Hum Mol Genet* 12: 2491–2501.
- Murray JC, Daack-Hirsch S, Buetow KH, Munger R, Espina L, et al. (1997) Clinical and epidemiologic studies of cleft lip and palate in the Philippines. *Cleft Palate Craniofac J* 34: 7–10.
- Romitti PA, Munger RG, Murray JC, Daack-Hirsch S, Hanson JW, et al. (1998) The effect of follow-up on limiting participation bias in genetic epidemiologic investigations. *Eur J Epidemiol* 14: 129–138.
- Wilkie AOM, Tang Z, Elanko N, Walsh S, Twigg SRF, et al. (2000) Functional haploinsufficiency of the human homeobox gene *MSX2* causes defects in skull ossification. *Nat Genet* 24: 387–390.
- Castanet M, Park SM, Smith A, Bost M, Léger J, et al. (2002) A novel loss-of-function mutation in *TTF-2* is associated with congenital hypothyroidism, thyroid agenesis and cleft palate. *Hum Mol Genet* 11: 2051–2059.
- Debeer P, de Ravel TJL, Devriendt K, Frys JP, Huysmans C, et al. (2002) Human homologues of *Osr1* and *Osr2* are not involved in a syndrome with distal limb deficiencies, oral abnormalities, and renal defects. *Am J Hum Genet* 111: 455–456.
- Zhang HT, Fei QY, Chen F, Qi QY, Zou W, et al. (2003) Mutational analysis of the transforming growth factor β receptor type I gene in primary non-small cell lung cancer. *Lung Cancer* 40: 281–287.
- Nickerson DA, Tobe VO, Taylor SL (1997) PolyPhred: Automating the detection and genotyping of single nucleotide substitutions using fluorescence-based resequencing. *Nucleic Acids Res* 25: 2745–2751.
- Cann HM, Toma C, Cazes L, Legrand MF, Morel V, et al. (2002) A human diversity cell line panel. *Science* 296: 261–262.
- Blencowe BJ (2000) Exonic splicing enhancers: Mechanism of action, diversity and role in human genetic diseases. *Trends Biochem Sci* 25: 106–110.

33. Graveley BR (2000) Sorting out the complexity of SR protein functions. *RNA* 6: 1197–1211.
34. Wang Z, Rolish ME, Yeo G, Tung V, Mawson M, et al. (2004) Systematic identification and analysis of exonic splicing silencers. *Cell* 119: 831–845.
35. Sunyaev S, Ramensky V, Bork P (2000) Towards a structural basis of human non-synonymous single nucleotide polymorphisms. *Trends Genet* 16: 198–200.
36. Sunyaev S, Ramensky V, Koch I, Lathe W 3rd, Kondrashov AS, et al. (2001) Prediction of deleterious human alleles. *Hum Mol Genet* 10: 591–597.
37. Ramesny V, Bork P, Sunyaev S (2002) Human non-synonymous SNPs: Server and survey. *Nucleic Acids Res* 30: 3894–3900.
38. Ranade K, Chang MS, Ting CT, Pei D, Hsiao CF, et al. (2001) High-throughput genotyping with single nucleotide polymorphisms. *Genome Res* 11: 1262–1268.
39. Shi M, Caprau D, Dagle J, Christiansen L, Christensen K, et al. (2004) Application of kinetic polymerase chain reaction and molecular beacon assays to pooled analyses and high-throughput genotyping for candidate genes. *Birth Defects Res A Clin Mol Teratol* 70: 65–74.
40. Laird NM, Horvath S, Xu X (2000) Implementing a unified approach to family-based tests of association. *Genet Epidemiol* 19 Suppl 1: S36–42.
41. Rabinowitz D, Laird N (2000) A unified approach to adjusting association tests for population admixture with arbitrary pedigree structure and arbitrary missing marker information. *Hum Hered* 50: 211–223.
42. Horvath S, Xu X, Laird NM (2001) The family based association test method: strategies for studying general genotype-phenotype associations. *Eur J Hum Genet* 9: 301–306.
43. Bonferroni CE (1936) Teoria statistica delle classi e calcolo delle probabilità. *Pubblicazioni del R Istituto Superiore di Scienze Economiche e Commerciali di Firenze* 8: 3–62.
44. Vieira AR, Karras JC, Orioli IM, Castilla EE, Murray JC (2002) Genetic origins in a South American clefting population. *Clin Genet* 62: 458–463.
45. Vieira AR, Orioli IM, Castilla EE, Cooper ME, Marazita ML, et al. (2003) MSX1 and TGFB3 contribute to clefting in South America. *J Dent Res* 82: 289–292.
46. Weinberg CR (1999) Allowing for missing parents in genetic studies of case-parent triads. *Am J Hum Genet* 64: 1186–1193.
47. De Felice M, Ovitt C, Biffali E, Rodriguez-Mallon A, Arra C, et al. (1998) A mouse model for hereditary thyroid dysgenesis and cleft palate. *Nat Genet* 19: 395–398.
48. Jiang R, Lan Y, Chapman HD, Shawber C, Norton CR, et al. (1998) Defects in limb, craniofacial, and thymic development in Jagged2 mutant mice. *Genes Dev* 12: 1046–1057.
49. Zhao Y, Guo YJ, Tomac AC, Taylor NR, Grinberg A, et al. (1999) Isolated cleft palate in mice with a targeted mutation of the LIM homeobox gene Lhx8. *Proc Natl Acad Sci U S A* 96: 15002–15006.
50. Karolyi J, Erickson RP, Liu S, Killewald L (1990) Major effect on teratogen-induced facial clefting in mice determined by a single genetic region. *Genetics* 126: 201–205.
51. Lammer EJ, Shaw GM, Iovannisci DM, van Waes J, Finnell RH (2004) Maternal smoking and the risk of orofacial clefts: Susceptibility with NAT1 and NAT2 polymorphisms. *Epidemiology* 15: 150–156.
52. Lan Y, Ovitt CE, Cho ES, Maltby KM, Wang Q, et al. (2004) Odd-skipped related 2 (*Osr2*) encodes a key intrinsic regulator of secondary palate growth and morphogenesis. *Development* 131: 3207–3216.
53. Celli J, Duijf P, Hamel BCJ, Bamshad M, Kramer B, et al. (1999) Heterozygous germline mutations in the p53 homolog p63 are the cause of EEC syndrome. *Cell* 99: 143–153.
54. Peters H, Neubuser A, Kratochwil K, Balling R (1998) Pax9-deficient mice lack pharyngeal pouch derivatives and teeth and exhibit craniofacial and limb abnormalities. *Genes Dev* 12: 2735–2747.
55. Reich A, Sapir A, Shilo B (1999) Sprouty is a general inhibitor of receptor tyrosine kinase signaling. *Development* 126: 4139–4147.
56. Jerome LA, Papaioannou VE (2001) DiGeorge syndrome phenotype in mice mutant for the T-box gene, *Tbx1*. *Nat Genet* 27: 286–291.
57. Yagi H, Furutani Y, Hamada H, Sasaki T, Asakawa S, et al. (2003) Role of *TBX1* in human del22q11.2 syndrome. *Lancet* 362: 1366–1373.
58. Bush JO, Lan Y, Jiang R (2004) The cleft lip and palate defects in Dancer mutant mice result from gain of function of the *Tbx10* gene. *Proc Natl Acad Sci U S A* 101: 7022–7027.
59. Kaartinen V, Voncken JW, Shuler C, Warburton D, Bu D, et al. (1995) Abnormal lung development and cleft palate in mice lacking TGF-beta-3 indicates defects of epithelial-mesenchymal interaction. *Nat Genet* 11: 415–421.
60. Proetzel G, Pawlowski SA, Wiles MV, Yin M, Boivin GP, et al. (1995) Transforming growth factor-B3 is required for secondary palate fusion. *Nat Genet* 11: 409–414.