

Mental Workload While Driving: Effects on Visual Search, Discrimination, and Decision Making

Miguel A. Recarte
Universidad Complutense

Luis M. Nunes
Dirección General de Tráfico

The effects of mental workload on visual search and decision making were studied in real traffic conditions with 12 participants who drove an instrumented car. Mental workload was manipulated by having participants perform several mental tasks while driving. A simultaneous visual-detection and discrimination test was used as performance criteria. Mental tasks produced spatial gaze concentration and visual-detection impairment, although no tunnel vision occurred. According to ocular behavior analysis, this impairment was due to late detection and poor identification more than to response selection. Verbal acquisition tasks were innocuous compared with production tasks, and complex conversations, whether by phone or with a passenger, are dangerous for road safety.

Lack of attention to relevant driving events is one of the main factors in traffic accidents (Rumar, 1990), and the concept of distraction is frequently used to refer to this lack of attention or to attending to something irrelevant. The result of distraction is an impaired capacity to process relevant information (Rumar, 1990) because of perceptual inefficiency and/or inadequate response selection. Attention is necessary for conscious perception (LaBerge, 1995; Mack & Rock, 1998; Titchener, 1908; Von Helmholtz, 1924), but engaging in events unrelated to driving could also directly affect decision processes, producing incorrect or late response selection. Phenomena such as the “psychological refractory period” (Heuer, 1996; Pashler & Johnston, 1998, Pashler, Johnston, & Ruthruff, 2001) indicate that a difficulty to perform two tasks simultaneously arises when both tasks require a central process of evaluation and response generation; that is, the attentional interference occurs at central processing levels.

With regard to attentional capture, using Posner’s (1980) terminology, distraction can be exogenous—produced by external objects or events irrelevant to driving—or endogenous—produced by the driver’s own thoughts or cognitive activity unrelated to the driving task. The implications of exogenous distraction on driving are different from those of endogenous distraction because, in addition to attentional capture, exogenous distraction usually captures the gaze, which means withdrawing it from the road ahead. It is easy to understand how one cannot see because of not looking, but it is less obvious to explain how one looks but does not see. The experiments of Recarte and Nunes (2000) provide evidence to

hypothesize about the possible role of endogenous distraction as a source of visual processing impairment.

Despite the applied relevance of attention for driving, research on distraction is scarce, being mainly based on simulator studies (Bossi, Ward, Parkes, & Howarth, 1997; Huges & Cole, 1988; Theeuwes, 1996) and mostly focused on exogenous distracting factors. Some studies conducted in real driving conditions have focused on external distractors or on increased visual load, for instance, the effect of advertisement panels (Luoma, 1986, 1988), traffic complexity (Miura, 1990), in-vehicle displays (Summala, Nieminen, & Punto, 1996), or interaction between road type and driving experience, both interpreted in terms of attentional demands (Crundall & Underwood, 1998). According to Miura (1990), the probability of detecting in-vehicle stimuli decreases in more complex scenarios, but this could be due to the mere impossibility of looking at the traffic ahead and somewhere inside the vehicle at the same time. On the contrary, research on interference caused by endogenous distractors provides a more direct approach to study higher level interference processes: If the distractors have no explicit foveal load, then their effects cannot be explained by mere functional constraints of the human eye. In addition to this theoretical implication, being engaged in one’s own affairs and concerns while driving has, in itself, an applied interest because it represents a common everyday situation that has received little attention in the research field.

Using concurrent tasks with no foveal load (mental tasks), the studies of Recarte and Nunes (2000) and Recarte, Nunes, and Conchillo (in press) directly approach the relationships between attention and gaze in real driving. Recarte and Nunes (2000) studied the effects of different mental tasks on visual behavior and driving performance. The increased workload required by several mental tasks was reflected in a significant pupil size increment, and several measures of visual search behavior were also affected by mental tasks. Among the general effects were a spatial gaze concentration (lower variability in spatial gaze direction) and reduced inspection frequency of mirrors and speedometer, although with no evidence of significant changes in specific driving perfor-

Miguel A. Recarte, Department of Basic Processes, Universidad Complutense, Madrid, Spain; Luis M. Nunes, Dirección General de Tráfico, Madrid, Spain.

This research was supported by the Dirección General de Tráfico, which provided the human, economic, and material resources that made it possible.

Correspondence concerning this article should be addressed to Luis M. Nunes, Dirección General de Tráfico, c/o Josefa Valcárcel 28, 28027, Madrid, Spain. E-mail: argos@dgte.es

mance measures, such as speed. Tasks with high spatial imagery content produced not only more pronounced effects but also a particular pattern of long fixations. To understand the significance of the observed changes, two main issues need to be addressed: the specificity of the effects regarding differences between tasks and the evaluation of mental activity as a potential distractor concerning road safety.

In a similar experiment (Recarte et al., in press), two types of content (verbal–spatial) were combined with two types of processes (acquisition–production). The production tasks, analogous to those of the first experiment, required continuous verbal responses about spatial or verbal (abstract) content. The acquisition tasks consisted of attending to and keeping in mind the content of audio messages with different types of content. To motivate the drivers to attend the messages, the authors advised participants that a subsequent recall test would be performed after each acquisition task. For production tasks, the results showed content effects, reproducing the same findings of the first experiment, but no effects, or practically null effects, occurred with the acquisition tasks.

In conclusion, whereas some cognitive tasks cause drivers to change their visual search behavior to various extents, other tasks do not produce those changes. However, what do we know about the probability of missing relevant information or making wrong decisions? In addition, if decision processes are affected, then how is this impairment related to visual search changes? Spatial gaze concentration can be considered a plausible mechanism to optimize visual resource allocation by increasing the priority assigned to the road ahead. In contrast, the eventual negative value of reduced inspection of peripheral areas should also be considered. Why do the relative priorities assigned to central and peripheral areas of the visual field change with mental tasks? Is it due to optimization, impairment, or a trade-off between both?

Neither the present theories nor the available empirical knowledge about ocular behavior provides a conclusive interpretation of the observed effects and their applied significance for driving and road safety. As the relevance of central and peripheral areas on a road scene depend on each particular traffic situation and on the drivers' intentions, it is not possible to make a general statement about which is the optimum spatial gaze distribution to maximize drivers' situation awareness and minimize the risk of misperception or wrong decisions.

The aims of the present research are (a) to extend the scope of previous studies to perceptual and decision capacities and (b) to increase the ecological value of the research by testing other tasks more related to everyday life. By means of simultaneous analysis of visual behavior and an additional visual-detection and discrimination test, we attempt to provide empirical evidence to understand the significance of the visual search concentration effect and, as far as possible, to identify possible mechanisms of interference of information-processing stages.

More precisely, the aim of this research is to answer the following questions. Regarding the potential distraction resulting from mental activity, do mental tasks affect visual-detection and response-selection capacities? Regarding the relation of these capacities with visual search changes, what is the relationship between gaze distribution and detection probability? In other words, if the results show a detection impairment effect, then does it equally affect the entire visual field or is the spatial concentration

of fixations associated with peripheral information impoverishment? In contrast, tasks that do not produce visual search changes might affect detection or decision capacities. In particular, the comparison of acquisition and production tasks would be highly informative if their effects on visual search reproduce previous findings. Regarding possible interference mechanisms, if there is some impairment in detection capacities, is it attributable to perceptual impairment or to difficulties in response selection? In reference to the generalization of the effects, will previous findings be reproduced with different, although comparable, acquisition and production tasks and with other tasks of intrinsic applied interest, used as examples of current daily life activity while driving?

To address these issues, we decided to carry out the present experiment. In operative terms, some assumptions and hypotheses are derived from the above-mentioned aims. To assess the visual-detection and response-selection capacities, a visual-detection and discrimination test was implemented in an instrumented vehicle, allowing the controlled presentation of visual stimuli and the measurement of response parameters—detections versus omissions, correct responses versus errors, and response times. A performance impairment effect would be accepted if lack of detection, erroneous responses, or increased response times attributable to mental tasks were observed. We assume that this test is meaningful and representative of some realistic relevant traffic events. Although more details of this test are provided in the Method and *Instruments* sections, the test consisted of presentation of flashing spotlights in conditions of spatial and temporal uncertainty. Similar experimental settings have been used in comparable experiments: Miura (1990), Lee and Triggs (1976), and Pottier (1999) used similar techniques to evaluate visual attentional changes due to traffic conditions or external distractors. The abrupt onset of a stimulus may produce a stimulus-driven attentional capture (Theeuwes & Godijn, 2001; Yantis & Jonides, 1984), but if attention is currently focused on or demanded somewhere else (Wright & Ward, 1998), this capture may either not occur or may lead to processing impairment.

With regard to the detection test and its possible relation to spatial gaze concentration, we contemplated a specific hypothesis: If spatial gaze concentration causes impairment of detection–discrimination capacities, then this impairment would be more pronounced in the periphery of the visual field; that is, a tunnel vision effect would occur. Contrariwise, if the impairment of detection equally affects the entire visual field, we should accept a phenomenon of general interference.

Therefore, the eventual gradient of impairment is analyzed as a function of visual target eccentricity. This gradient of impairment is obtained by comparing the eccentricity–detection gradients corresponding to ordinary driving and to mental task performance driving. According to the tunnel vision hypothesis (Rantanen & Goldberg, 1999; Williams, 1985, 1988), a higher degree of impairment should occur for higher eccentricities when comparing both eccentricity gradients. In other words, the reduction of peripheral identification or discrimination capacity should be more pronounced for more eccentric targets when compared with the reduction occurring for more central targets (Holmes, Cohen, Heith, & Morrison, 1977), which means that the peripheral areas are selectively more affected. This is different from a general

interference phenomenon in which the entire visual field is equally affected, independently of eccentricity.

According to Sanders and Donk (1996), the tunnel vision effect has not been clearly demonstrated. However, the results obtained by authors such as Bossi et al. (1997), Van der Weijert and Van der Klok (1999), or Williams (1988, Experiment 1) support the general interference hypothesis.

Another hypothesis to verify with regard to the relation between spatial gaze concentration and decision-making impairment depends on the replication of the lack of visual changes with acquisition tasks: If, despite no visual search changes, there are effects on detection or on response selection, then there is empirical evidence of independence of gaze concentration and processing impairment. This hypothesis should be analyzed together with results about the tunnel vision effect. The dependence or independence of visual search changes and detection–decision capacities could either be mutually reinforced or could display opposite results.

Considering the relations between gaze concentration and detection–decision performance, an important question must still be raised before verifying the above-stated hypothesis: The visual load imposed by the visual-detection test could interact with the effect of mental tasks, producing a bias in the spatial gaze concentration results, thus making it impossible to distinguish between the effects attributable to mental tasks and those attributable to the detection test. In consequence, the experimental design must allow for discarding a possible interaction between mental tasks and detection test. Hypothetically, we expected that the drivers, when performing the detection test, would frequently glance at the targets to identify them. As some targets are displayed on quite peripheral areas of the visual field, we predicted that the detection test would cause increased spatial gaze dispersion, contrary to the concentration effect of mental tasks. However, we expected a simple additive effect, as there is no apparent cause to expect an interaction. If our hypothesis were verified, then the combined analysis of the results of detection and mental tasks would provide more information to understand the relation between these variables.

Regarding discrimination and response selection, we considered a second question. In the case of incorrect responses, do the errors represent a failure in the discrimination of the stimulus characteristics or an impaired capacity to apply the decision rule to perform the response? In a natural environment such as driving, a detection task involving spatial and temporal uncertainty of target activation leads to a process of multifixational search (Sanders, 1998) and may produce response times of several seconds because the gaze may be directed at other locations (or the person may be blinking) when the target appears. In addition, sufficient information must be extracted before responding. Although Sanders (1998) pointed out the difficulty of hypothesizing about underlying processes with time lapses of over 2 s, in our natural setting, we proposed a technique to analyze the total time meaningfully by splitting it into three components: before, during, and after fixating the target. Despite the accepted independence of attention and gaze (Posner, 1980), gaze and visual attention are usually coincident in ordinary situations (Moray, 1993). Unless a top-down control prevents it (i.e., a traffic situation must be observed), peripheral perception of a target causes a saccade toward the target that is assumed to have been programmed in a previous fixation while looking elsewhere

(Rayner, 1998). Once a target is fixated, information must be extracted to achieve the discrimination task and select the appropriate response. Although the peripheral perception achieved in the previous fixation may provide part of the information required, we expected that most of the detected targets would be glanced at and, for these cases, we decided to split the time into three stages: (a) a first stage, or time since the stimulus is activated until it is glanced at, with mainly perceptive components, which we called *perception time*; (b) a second stage, or time the stimulus is being fixated, with mainly information extraction and elaboration components, which was called *inspection time*; and (c) a third stage, or time since the eye leaves the target until the manual response is given, with mainly components of decision rule application (which must be kept active or recovered in each case), which was called *decision time*. We thus hypothesized different interpretation of the effects of performing a mental task on the duration of each of these stages. The mental task could affect the detectability of the target (first stage), the identification of the target (processing target information—second stage), or the response selection (third stage).

To address the issue of the generalization of the effects to other tasks, we decided to replicate with other tasks the previously found differences between acquisition and production processes and to extend the study to other cognitive activities more similar to everyday spontaneous mental activity, such as episodic recall or mental calculus. In addition, in view of the relevance of mobile phones in traffic research (see Haigney & Westerman, 2001, for a recent review), we decided to study the impact of the cognitive load imposed by phone conversations when the conversation content is controlled and phone manipulation tasks, such as dialing or searching in the phone menu, are excluded; that is, to compare the effects of hands-free phone conversations with those of equivalent conversations performed in live interaction with a passenger.

Hypothetically, if the acquisition versus production differences are reproduced with other tasks, two consequences are derived: (a) There should be stronger empirical support to generalize the different effects attributed to acquisition and production processes, and (b) as already noted, there should be an opportunity to test whether tasks causing no visual search changes (acquisition tasks) would be innocuous in terms of detection or response-selection impairment. With respect to the phone conversations, we hypothesized that if the phone setting imposes an additional workload compared with standard verbal communication, then differences should be found between phone and live versions of equivalent cognitive tasks.

In summary, in this experiment, there is a triple task situation in which attention must be divided among driving, visual target discrimination, and mental tasks, either by resource assignment or by a time-sharing strategy. In ordinary driving, neither thoughts nor the driving task require the high processing density of most common laboratory experiments. Although occurrence of traffic events is uncontrolled in a field experiment, if we experimentally induce drivers' attention to maintain a mental set to be alert to the visual targets presented with spatial and temporal uncertainty, we expected that, on a statistical level, some targets will not be detected or will be insufficiently processed, particularly when attention is allocated to the performance of some more demanding mental task.

To overcome the unwanted variability imposed by the natural traffic environment, we tested the different conditions for a suffi-

ciently long interval to provide a large number of observations and to allow the experimental comparison of eye-movement and detection data. To replicate the previous findings concerning visual search changes, we selected as relevant variables (a) pupil size, as a measurement of effort due to the added mental load; (b) spatial gaze variability, as a measurement of the alteration of visual search patterns; and (c) the frequency of rearview mirror and speedometer inspection, as a visual search measure with particular applied significance and closely related with the degree of situation awareness during driving. These visual search measures are obtained from the primary data about the ocular fixation coordinates measured with respect to the visual field; that is, x and y gaze coordinates on the scenario, integrating online eye and head motion. To evaluate detection and response-selection performance, the percentage of detected targets, correct discrimination responses, response times, and the described response-time stages were used.

Method

Participants

Six men and 6 women, with a mean age of 23.4 years ($SD = 2.5$ years), drove an instrumented vehicle on a highway in real traffic. All of them had more than 3 years of driving experience ($M = 4.8$ years, $SD = 2.3$), and on average, they drove 4.6 days a week ($SD = 1.6$) and 1.5 hr a day ($SD = 0.9$), with a total mean mileage of 59,000 km ($SD = 46,000$). All of them met the standard visual acuity criteria for driving with no corrected vision, were not familiar with the experimental vehicle, and were paid for their participation.

Experimental Conditions and Design

The driving task was always present in the experiment and, with respect to mental task performance, constituted the no-task control condition, which was the baseline to evaluate the visual search effects of eight different mental tasks that were organized in the following subsets according to particular objectives: Two acquisition tasks (one of abstract and the other of concrete content) and two production tasks (also abstract and concrete) were selected to replicate the above-mentioned acquisition versus production differences (the process–content subdesign), and another four tasks were selected to test the stated hypothesis about phone communication—two examples of daily life cognitive tasks were performed in live conversation or by phone (two live–phone subdesigns). In total, there were nine mental task conditions: eight tasks and one control (no task).

Regarding the detection, discrimination, and response-selection test, we defined two conditions (no detection vs. detection), consisting of the presence or absence of the detection test. As already commented, because of the prior need to evaluate the effects of the detection test in visual search and, in particular, the possible interference between the detection test and the mental tasks, the two detection conditions were orthogonally crossed with the mental task conditions. Two blocks containing equivalent mental tasks were balanced between detection conditions. Within each block, mental task periods of 2 min were alternated with 2-min control periods in which no mental tasks were performed. The order of both detection blocks was counterbalanced among participants and gender. In addition to the aforementioned ocular variables, and as a complementary measure of effort in addition to the pupil diameter, after finishing each task, participants rated on a 10-point scale the subjective effort they attributed to the performance of each task while driving. Detection probability, decision errors, glances at detected targets, and response times—with the above-mentioned subdivision (perception, inspection, and decision times)—were the relevant dependent measures regarding the detection condition.

In summary, for the analysis of the ocular variables, a general design of 2 (detection: no detection vs. detection) \times 9 (mental task: no task and 8

mental tasks) with repeated measures was used. In the analysis of the detection dependent measures, the no-detection block was obviously excluded.

Below is a description of the subdesigns, including a brief description of the mental tasks involved and their corresponding abbreviations. Details about the detection test are provided in the *Instruments* section.

The process and content subdesign combines the study of the acquisition versus production processes with the abstract (verbal) versus concrete (spatial) content. The following four tasks were included. There was a verbal abstract learning (VAL) task in which participants listened to an audio message with abstract content for 2 min. They had to attend to and keep in mind the message, as they were informed that they would need such information to perform the next task. The next task was a verbal abstract production (VAP) task, in which participants had to generate a free reproduction of the message they had just listened to in the VAL task. The third task was a verbal concrete learning (VCL) task, in which participants listened to a description that included spatial references to concrete objects and their sensory attributes. As in abstract learning, they were also told to mentally retain such information. Finally, there was a verbal concrete production (VCP) task, in which participants were asked to generate a free reproduction of the message they had just listened to in the VCL task.

For the analysis of the dependent variables related to gaze behavior, a 2 (processes: learning–production) \times 2 (content: abstract–concrete) \times 2 (detection conditions: no detection–detection) design with repeated measures was used. For the analysis of the dependent variables related to detection, we used a 2 (processes) \times 2 (contents) design, considering only the detection section.

Two live–phone subdesigns addressed the comparison of phone conversation with live communication in the car. This was also an attempt to increase the ecological value of the study by including two very different everyday tasks. Therefore, we decided not to mix both tasks and to retain them as two separate subdesigns for the phone study. The subdesigns were the mental calculus subdesign and the autobiographic recall subdesign. In the mental calculus subdesign, participants were asked to mentally change various amounts of euros to pesetas and vice versa. The experimenter paced the rhythm of the task according to the participant's performance. For successive applications, the quantities to be calculated were varied. An approximate conversion rule was suggested: 1,000 pesetas = 6 euros. Regarding the phone study, there were two versions of mental calculus: live euro and phone euro. In the live version, the experimenter traveling in the car verbally provided each item, whereas in the phone version, this was done by phone communication with a remote experimenter.

In the autobiographic recall subdesign, participants had to give detailed information about where they were and what they were doing on a given day and time. The equivalent versions of this task were obtained by varying the specified day and time (e.g., “4 days ago at 11 a.m.,” “6 days ago at 5 p.m.”). There were also two different task versions: live memory and phone memory.

For the analysis of ocular variables, the mental calculus tasks lead to a 2 (version: live–phone) \times 2 (detection conditions: no detection–detection) subdesign, also with repeated measures. Concerning the dependent variables related to detection, it was considered just one variable with two version modes. The same applied to the autobiographic recall (memory) tasks.

The outline of the subdesigns, all with repeated measures, is as follows: (a) process and content subdesign, 2 (process: learning–production) \times 2 (content: abstract–concrete), and (b) live–phone subdesigns, autobiographic recall (2 versions; live–phone) and mental calculus (2 versions; live–phone).

Instruments

The Argos instrumented car, a standard Citroën BX-GTI (Madrid, Spain), includes an unobtrusive eye-tracking system (Applied Science

Laboratories [ASL], Bedford, MA), details of which can be seen in Gottlieb, Scherbart, and Guse (1996). A general description of the vehicle functionality can be seen in Nunes and Recarte (1997). The system is able to provide numerical data about the vehicle dynamics, drivers' actions, and ocular variables. At the same time, several video cameras provide synchronized information about the driving scene and a cursor superimposed on the main road video scene reveals online gaze direction. The sampling rate for pupil size and x and y gaze coordinates in reference to the driving scene is 50 Hz, and the spatial accuracy of the gaze direction is in the range of $.5\text{--}1.0^\circ$ of visual angle. An algorithm was implemented to calculate the ocular fixations. A fixation was defined as a sequence of at least three consecutive samples in which gaze coordinates fall within a circle of no more than 1° of visual angle of diameter. More details on the fixations algorithm can be found in Recarte and Nunes (2000). The coordinates ($x = 0, y = 0$) were established so that they corresponded to a longitudinal axis parallel to the road and passing through the driver's eye so that they represent the glance direction when looking straight ahead in the same direction as the car trajectory. These coordinates also corresponded to the location of the focus of expansion in terms of the dynamic visual scene in a straight road. The driver's head is free from any attached device and natural head movements are allowed. The payoff for free head motion is a loss of about 10% of measurement time of ocular parameters; when due to broader head movements, the driver's eye falls outside of the available measurement range.

The vehicle also includes a system for automatic presentation of the visual targets for the detection test. A set of 10 flashing spotlights can appear in the driver's visual field in a spatial range of approximately 60° horizontally \times 25° vertically. Four of these targets (virtual targets) were obtained by reflection on the windshield surface. This effect was obtained by means of four light beams conveniently installed inside the vehicle. The other six targets (real targets) were directly perceivable inside the vehicle and consisted of high-luminance electronic-light-emitting diodes (LEDs), two installed on the left windshield pillar, three on the dashboard, and one in the lower left corner of the interior mirror. Two response buttons, one for each hand, were ergonomically installed near the steering wheel. The size of the targets was approximately 30 min/arc of visual angle. The 10 targets and the response buttons were arranged as indicated in Figure 1.

The virtual target (light beams) mean eccentricity with respect to the focus of expansion was ranged between 8° and 23° . The mean eccentricity of the six real targets (LEDs), located in more peripheral areas, was between 21.5° and 35.4° . The targets were flashing spotlights, and in the detection task, the participants were requested to distinguish between two flashing rates (high–low). A previous pilot study provided us with the optimum values for the target flashing rate and duration. It was decided that

each flashing target should remain activated for 3 s and that the interstimulus interval would vary between 12 s and 28 s, so that each experimental period of 2 min would contain five target presentations. The high flashing rate was achieved by flashing sequences of 0.2 s on–0.2 s off. The low flashing rate was 0.3 s on–0.3 s off. For half of the participants, the decision rule was “press left button for low rate, press right button for high rate” and vice versa for the other half of the participants.

Despite the efforts to match virtual and real target conspicuity, it was a difficult problem in a real vehicle and natural environment: The variability of the target–background contrast due to the variations in background luminance and color affected the targets' detectability. On the basis of previous tests, we identified some undesirable factors: (a) General daylight conditions affected all the targets; (b) structural differences (reflectance and color) of the vehicle dashboard surfaces systematically and selectively affected the real targets (the target–background contrast) in that some targets were systematically more conspicuous than others, independent of their eccentricity; and (c) the changing dynamic background of the external road scene affected the conspicuity of the virtual targets quite randomly, which made these targets more suitable for studying the eccentricity effect. In fact, despite the inconvenience, the virtual targets showed the normal eccentricity detectability gradient. To minimize this problem, we balanced target presentation across experimental conditions and we decided to use all the targets to study the general detection measures and only the subset of the virtual targets to analyze the eccentricity effect. Hence, the real targets, although unsuitable for eccentricity analysis, contributed to increase the general spatial unpredictability in the detection task and were still useful to analyze general detection effects, different from eccentricity.

The Experimental Sequence

Participants received very general information about the purpose of the study and were instructed about the type of tasks they had to perform during the drive. After the eye-tracking system calibration, participants were requested to drive until they felt comfortable with the vehicle. After the mere adaptation to the standard car controls, another learning period of adaptation to the mechanical manipulation of the response buttons was performed without visual target presentation, independently of the additional training phase required to learn the discrimination rule. Then, one of the two experimental blocks (the no-detection or the detection block) was initiated according to the order of the design.

The no-detection block consisted of performing the predefined sequences of 2-min periods of no task (control) and 2-min periods of mental tasks followed by the corresponding subjective effort rating. The mental tasks were inserted between control periods of no-task, with the exception of the transition between the learning and production tasks of the process and content subdesign: VAP came immediately after VAL and VCP came immediately after VCL, with no control interval between them. As participants had to keep in mind the content just heard to perform the production tasks, any interval between those tasks would have been used as a memory rehearsal period and not as a real control period.

Except for the concurrent performance of the detection test, the detection block was equivalent to the no-detection block regarding the sequence of control and mental task periods. However, a prior learning phase for the detection test was required. First, with the car at a standstill, the experimenter showed the participant several examples of flashing targets with high and low flashing rates. After a few minutes of standstill practice, when the participant was able to discriminate the flashing rate, there was a second learning stage in which the detection test was practiced in real driving for a few more minutes. Then, the detection block could be initiated according to the design by informing the participant that the detection test would be active all the time, independently of whether or not any mental task was performed. At the end of the detection block and with the vehicle at a halt, a second routine procedure was run to recalibrate the exact coordinates of the target location for each participant, adapting to his or her

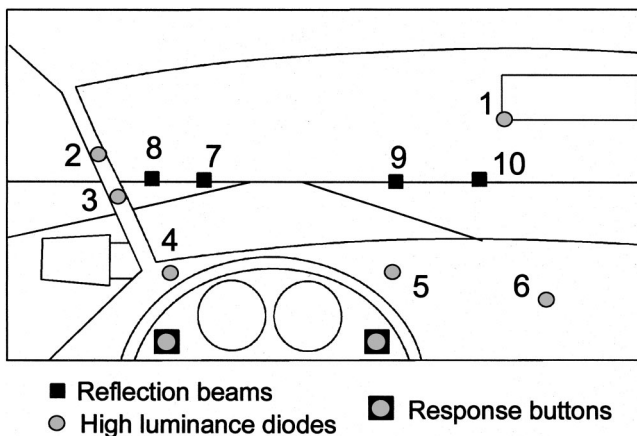

Figure 1. Locations for the target and response buttons.

height and position in the driver's seat. A short pause of 15 min was included to rest between detection and no-detection blocks. For all participants, the route used was highway N1 from Madrid to the north, on days with no rain, snow, or fog around midday. The experiment duration was about 4 hr for each participant, covering approximately 300 km. The experiment took place under normal traffic events. Particularities like traffic jams or road construction works going on were considered invalid conditions for the experiment.

Results

The presentation of results is organized in two sections: The first section, *Visual Search and Mental Tasks*, analyzes the effects of mental tasks on visual behavior. The second section, *Detection, Discrimination, and Response Selection*, analyzes the results of the detection task as a function of the mental load imposed by mental tasks. This section, however, also includes a particular case of visual behavior analysis: analysis of the glances at the detected targets and their interpretation in terms of processing stages of the detection task.

The *Visual Search and Mental Tasks* section includes the following analyses: (a) We performed a 2 (detection conditions) \times 9 (mental tasks) analysis of variance (ANOVA) with repeated measures and simple contrast between the no-mental-task condition and each of the other eight mental tasks for all the dependent variables; (b) for the process and content subdesign, we performed a 2 (processes: acquisition vs. production) \times 2 (contents: concrete vs. abstract) \times 2 (detection conditions) ANOVA with repeated measures; and (c) for the live-phone subdesigns, we performed two analogous analyses, one for the autobiographic recall subdesign—a 2 (detection conditions) \times 2 (versions: live vs. phone) ANOVA—and one for the mental calculus subdesign—a 2 (detection conditions) \times 2 (versions: live vs. phone) ANOVA.

The means and standard deviations of each variable, with and without detection, are displayed in Table 1. The following dependent variables were analyzed: (a) two measures of effort—pupil size and subjective effort rating; (b) one measure of spatial gaze variability, consisting of the area of the rectangle defined by two variability scores obtained for the horizontal and the vertical axis of the visual field—in operative terms, for each individual and experimental condition, it was the product (Standard Deviation of Horizontal Gaze Coordinates \times Standard Deviation of Vertical Gaze Coordinates); and (c) two measures of visual search, specifically meaningful for the driving task—the proportion of glances at the speedometer and at the rearview mirrors.

The presentation of the results in the *Detection, Discrimination, and Response Selection* section is less homogeneous in structure and is organized differently. There are several reasons for this. In the whole experiment, there were 960 cases of targets to be detected (480 displayed while driving with no mental task and 480 while performing some mental task, 60 with each individual task). Analysis by participant and individual task (needed to perform a repeated measures analysis like the one in the first section) is inconvenient or even impossible: For each combination of Participant \times Task, there were only five cases of target presentation, which obviously poses serious problems for this kind of analysis. Moreover, some dependent measures, such as correct responses or response times, impose additional restrictions on the number of cases: Only the detected targets can be analyzed, and, regarding the analysis of response-time stages as a function of glances, the

available cases are again reduced to only those targets that were glanced at. The result is that for some of the 12 (participants) \times 9 (tasks) combinations of conditions, there would be several cases with no data, which would critically reduce the degrees of freedom and produce many extreme values. Therefore, we decided to analyze the results on the basis of designs of Tasks \times Participants. All of the ANOVAs included Cohen's f as unbiased estimates of effect size (Cohen, 1988).

Visual Search and Mental Tasks

In this section, pupil diameter, effort ratings, spatial gaze variability, and glances at the speedometer and mirrors are analyzed.

Pupil. As an indicator of attentional effort, pupil size revealed no significant differences between detection and no detection (see Table 1 for data and Table 2 for ANOVA). When comparing each task with the no-task condition, we found statistically significant differences in the pupil diameter (a mean increment about 4% in a range between 2% and 6%) for all tasks that required response production except phone memory. We found no differences with respect to the two verbal learning tasks, and task-detection interactions were also nonsignificant.

With regard to the process and content subdesign, significant differences were only found between acquisition and production tasks. In the live-phone subdesigns, neither the mental calculus nor the autobiographic recall tasks revealed differences between their live and phone versions nor between detection versus no detection. Consequently, no additional effect was observed because of the use of the phone as a communication device, over and above the effect imposed by the mental tasks themselves.

Subjective effort rating. The subjective effort rating for each task can be seen in Table 1, and the results of the ANOVA are displayed in Table 3. As there were no differences regarding detection, we refer to the total results of detection and no detection. In the process and content subdesign, the production tasks were rated as more effortful than the learning tasks, which is in accordance with pupillary dilation data. Pupil results also agree with the high effort ratings assigned to each of the euro versions (live and by phone). The two memory versions (live and by phone) were the exception: Despite low effort ratings, they clearly produced a pupillary dilation effect, practically the same as the mental calculus task.

We also highlight that the phone task versions were systematically (on four occasions) rated as more effortful compared with the equivalent live versions. The difference was small and only significant for memory, but this result has also been observed in other cases.

Spatial gaze variability. The data of the spatial variability scores, representing the area of a rectangle of 1 Standard Deviation of Horizontal Gaze Coordinates \times 1 Standard Deviation of Vertical Gaze Coordinates, calculated for each individual and condition, is displayed in Table 1 and the ANOVA results appear in Table 4. For the general results, we highlight three relevant aspects: (a) As expected, the performance of the detection test produced a higher spatial dispersion that, in our opinion, reflects the occurrence of glances to look for and identify the targets (we come back to this point in more detail in the *Detection, Discrimination, and Response Selection* section); (b) the spatial gaze concentration effect was systematically produced for all the mental

Table 1
Means and Standard Deviations of all Dependent Variables (Except Response Times) for Each Task, No-Task, and Detection Conditions

Variable	Experimental condition								
	No task	Learning		Production		Euro		Memory	
		VAL	VCL	VAP	VCP	Live	Phone	Live	Phone
Pupil size (pixels)									
No detection									
<i>M</i>	711	719	711	741	726	750	752	740	749
<i>SD</i>	83	98	78	109	83	90	85	82	93
Detection									
<i>M</i>	728	724	732	741	771	759	753	774	731
<i>SD</i>	90	88	82	97	100	98	84	115	56
Subjective effort (10-point scale)									
No detection									
<i>M</i>		4.75	5.29	5.67	6.17	7.88	8.33	5.04	5.42
<i>SD</i>		1.62	1.60	1.25	1.86	0.80	1.07	1.10	1.49
Detection									
<i>M</i>		5.08	5.29	5.75	5.79	8.08	8.08	4.75	5.79
<i>SD</i>		1.62	1.84	2.25	1.56	1.10	1.06	2.02	1.16
Spatial gaze variability (square degrees)									
No detection									
<i>M</i>	36.47	26.61	15.90	19.84	15.76	14.40	12.43	18.29	14.89
<i>SD</i>	17.88	17.64	9.08	21.10	9.70	11.85	7.85	17.27	5.86
Detection									
<i>M</i>	49.96	42.12	38.02	22.90	23.29	20.22	16.35	21.31	20.10
<i>SD</i>	21.84	26.59	24.74	10.07	16.30	15.93	9.01	14.53	14.24
Glances at speedometer (%)									
No detection									
<i>M</i>	3.16	2.10	0.79	1.12	0.72	0.40	0.25	1.19	0.42
<i>SD</i>	2.61	2.87	1.02	1.83	1.39	0.84	0.54	3.64	0.57
Detection									
<i>M</i>	2.69	1.96	1.51	0.57	0.45	0.59	0.65	0.69	0.63
<i>SD</i>	2.22	2.07	1.80	0.92	0.70	1.04	0.80	1.12	1.07
Glances at rearview mirror (%)									
No detection									
<i>M</i>	1.34	1.42	1.10	0.25	0.92	0.60	0.05	0.31	0.54
<i>SD</i>	1.06	1.84	1.19	0.51	0.96	0.89	0.18	0.47	0.83
Detection									
<i>M</i>	1.27	1.42	1.09	0.77	0.87	0.23	0.18	0.14	0.25
<i>SD</i>	0.97	0.82	1.20	0.70	1.24	0.42	0.39	0.47	0.41
Detected targets (%)									
Detection									
<i>M</i>	77.29	75.00	78.33	55.00	65.00	55.00	66.67	65.00	55.00
<i>SD</i>	41.94	43.67	41.55	50.17	48.10	50.17	47.54	48.10	50.17
Correct responses (%)									
Detection									
<i>M</i>	90.57	86.67	93.62	78.79	87.18	75.76	80.00	87.18	75.76
<i>SD</i>	29.27	34.38	24.71	41.51	33.87	43.52	40.51	33.87	43.52
Glances at the targets (%)									
Detection									
<i>M</i>	71.88	63.33	66.67	41.67	48.33	38.33	48.33	55.00	50.00
<i>SD</i>	45.01	48.60	47.54	49.72	50.39	49.03	50.39	50.17	50.42

Note. VAL = verbal abstract learning; VCL = verbal concrete learning; VAP = verbal abstract production; VCP = verbal concrete production.

tasks tested (the variability scores showed a reduction from 16% to 77% and the great majority were over 50%); and (c) no interaction was found between detection and mental tasks.

In the process and content subdesign, in addition to the aforementioned difference attributable to detection, there was a process effect: The spatial gaze concentration was higher for the production tasks than for the acquisition tasks (production tasks, compared with acquisition tasks, scored 38% less in

variability). In the live–phone subdesigns, we found no differences between live and phone versions either in mental calculus or in memory tasks.

Glances at the speedometer. Speedometer inspection was affected by mental tasks but not by detection tests. When compared with no task, all tasks showed significant differences and no interaction with detection: Mental tasks produced a reduction in the percentage of glances at the speedometer. The magnitude of the

Table 2
Pupil Size (Pixels) Analysis of Variance With Repeated Measures: General Design, Process and Content Subdesign, and Both Live–Phone Subdesigns

Source	MS (df = 1)	F	Cohen's <i>f</i>	MSE (df = 11)
General design				
Detection	1,998.79	1.39	0.36	1,434.28
Task–no task				
Verbal abstract learning	43.09	0.08	0.09	531.46
Verbal concrete learning	49.51	0.10	0.10	481.64
Verbal abstract production	5,527.76	4.91*	0.67	1,126.23
Verbal concrete production	10,354.73	11.17**	1.01	926.83
Live Euro	14,622.04	13.04**	1.09	1,121.48
Phone Euro	13,092.75	8.74*	0.89	1,498.13
Live memory	16,597.96	18.43**	1.29	900.45
Phone memory	5,068.02	4.42	0.63	1,146.77
Detection × Task				
Verbal abstract learning	1,981.77	0.53	0.22	3,737.30
Verbal concrete learning	195.51	0.37	0.18	534.10
Verbal abstract production	3,532.17	0.30	0.17	11,784.47
Verbal concrete production	9,907.78	1.65	0.39	6,010.29
Live Euro	849.34	0.15	0.12	5,559.78
Phone Euro	3,372.57	0.85	0.28	3,957.78
Live memory	3,255.57	1.05	0.31	3,090.37
Phone memory	14,973.48	3.20	0.54	4,680.26
Process and content subdesign				
Detection	15,868.21	1.16	0.32	13,685.08
Content	194.34	0.24	0.15	816.78
Process	6,602.11	8.86*	0.90	745.30
Detection × Content	11,823.26	1.13	0.32	10,476.26
Detection × Process	1,247.51	0.36	0.18	3,420.06
Content × Process	181.41	0.32	0.17	569.76
Detection × Content × Process	2,523.56	0.72	0.26	3,527.23
Live–phone—Euro subdesign				
Detection	576.85	0.15	0.12	3,741.63
Version	21.11	0.03	0.05	710.00
Detection × Version	418.49	0.11	0.10	3,827.84
Live–phone—Memory subdesign				
Detection	1,561.00	0.55	0.22	2,850.39
Version	1,661.36	1.34	0.35	1,236.23
Detection × Version	16,096.45	4.11	0.61	3,920.41

Note. The general design analysis of variance was 2 (detection conditions) × 9 (mental tasks). Euro refers to the mental calculus task; memory refers to the autobiographic recall task.

* $p < .05$. ** $p < .01$.

reduction with respect to no task was near 70% as a mean and ranged from 27% to 92% (see Tables 1 and 5).

In the process and content subdesign, there was a significant process effect: For the production tasks, the glances at the speedometer dropped with respect to verbal learning tasks. A slight Content × Process interaction was also observed, indicating that the difference between learning and production is more pronounced with abstract than with concrete content.

In the live–phone subdesigns, there were no differences between live and phone versions, nor was there any interaction with detection for any of the tested tasks (memory and euro). That is, on four occasions, we obtained the same null results.

Glances at rearview mirrors. The data and the results of the ANOVA of the internal or external mirror inspection frequency can be seen, respectively, in Tables 1 and 6. No differences in mirror inspection resulting from detection–no detection were observed, nor was any interaction between detection and task observed. Significant differences were found for all tasks, except for the two verbal learning tasks and for VCP. Mental tasks caused a reduction in rearview mirror inspection.

In the process and content subdesign, only differences due to process (learning–production) were observed. In the live–phone subdesigns, no significant differences were observed that could be attributed to the phone, either in the euro or the memory tasks.

Table 3
Subjective Effort Rating (10-Point Scale) Analysis of Variance With Repeated Measures: General Design, Process and Content Subdesign, and Both Live-Phone Subdesigns

Source	<i>MS</i> (<i>df</i> = 1)	<i>F</i>	Cohen's <i>f</i>	<i>MSE</i> (<i>df</i> = 11)
General design				
Detection	0.01	0.00	0.00	1.99
Task	46.93	12.93**	1.08	3.63
Detection × Task	0.10	0.04	0.00	2.30
Process and content subdesign				
Detection	0.00	0.00	0.00	2.29
Content	2.50	1.14	0.31	2.19
Process	13.13	8.15*	0.87	1.61
Detection × Content	0.94	0.46	0.20	2.05
Detection × Process	0.59	0.77	0.27	0.76
Content × Process	0.07	0.10	0.10	0.64
Detection × Content × Process	0.02	0.03	0.00	0.81
Live-phone—Euro subdesign				
Detection	0.01	0.01	0.00	0.54
Version	0.63	1.44	0.37	0.44
Detection × Version	0.63	3.00	0.52	0.21
Live-phone—Memory subdesign				
Detection	0.02	0.01	0.00	2.29
Version	6.02	6.81*	0.78	0.88
Detection × Version	1.33	1.74	0.40	0.77

Note. The general design analysis of variance was 2 (detection conditions) × 8 (mental tasks). Euro refers to the mental calculus task; memory refers to the autobiographic recall task.

* $p < .05$. ** $p < .01$.

Detection, Discrimination, and Response Selection

Detection. A total of 960 targets was presented, 480 with mental task and 480 with no mental task. In the analyses, the targets were considered detected if a response was given, regardless of whether it was correct. During no-task periods, the participants detected 77.3% of the targets, but this percentage dropped significantly to 64.4% when performing mental tasks. A 12×9 (Participants × Task Conditions) ANOVA revealed significant differences in task conditions. When comparing each task with no task, almost all the tasks produced a significant reduction in the detection probability, with two expected exceptions (the two verbal acquisition tasks) and one unexpected exception (the phone version of mental calculus). These results and ANOVA data are displayed in Tables 1, 7, and 8, respectively.

In the process and content subdesign, only differences attributable to process were found, independently of the type of content. In the phone subdesigns, no differences were found between the live and phone versions either for mental calculus or for autobiographic recall tasks.

Correct discrimination responses. The percentage of correct responses to the targets was calculated with regard to the number of detected targets. In the no-task condition, 90.6% of the re-

sponses were correct, whereas with mental task, this percentage dropped to 83.8%. The task-by-task analysis with respect to the no-task condition (see Tables 1, 9, and 10) showed significant differences in verbal production tasks and in both phone tasks. With respect to subdesigns, no differences in the proportion of correct responses were found either in the process and content or in the live-phone subdesigns.

Response times. Considering the reaction times to the detected targets, no differences were found between task and no-task conditions: 2.09 s versus 2.10 s. Nonetheless, as mentioned earlier, analyzing the ocular responses to the targets allowed us to subdivide the total reaction time into three stages, that is, the time elapsed from the moment the target lit up until the response button was pressed. The three stages were as follows: (a) perception time (from target activation until the beginning of a saccade toward the target [in those cases in which it was glanced at]), (b) inspection time (time spent looking at the target); and (c) decision time (the time elapsed since the participant stopped looking at the target until the response button was pressed). The null effects in the total time could be due to the fact that the tasks affected the different time components in opposite directions. The subdivision of time into three stages allowed us to analyze the duration of each time stage as a function of the performance of mental tasks. However, before analyzing the three time components, we had to identify which stimuli, among those detected, were glanced at.

Glances at the targets and response time stages. Among the detected targets, 86% were glanced at; in 14% of the cases, the participants presumably identified the targets peripherally, as they responded without fixating them. However, if the glances at the targets were considered a function of the mental task, this percentage reached 91.37% when no mental task was performed and dropped to 78.74% with mental task performance. As can be observed in Tables 1, 11, and 12, the reduction in glances at the targets with mental task was significant for all the tasks, with the exception of the two verbal acquisition tasks.

If the stimulus-response times were subdivided into the three above-mentioned components, we found the data displayed in Figure 2. As can be seen, with mental task, perception time increased and inspection time decreased but the decision time remained unaltered. (The results of the multivariate analysis of variance can be seen in Table 13.)

Eccentricity and detection. Eccentricity was defined and measured as the visual angle between the target location and the actual gaze direction at the moment the target was activated. Given that target activation is independent of gaze direction in statistical terms, the mean eccentricity of a target obtained from individual eccentricity values is practically coincident with the mean target eccentricity with respect to the mean gaze direction close to the focus of expansion. In consequence, if the spatial gaze concentration causes some kind of visual impairment, the more peripheral targets (those with higher mean eccentricities) would be more affected.

To study the relation between eccentricity and detection, as already mentioned in the *Instruments* section, we used the subset of the four virtual targets (obtained by reflection of light beams; see Figure 1) to study the eccentricity effect. This was because the normal detectability gradient of the real targets (LEDs) with respect to their eccentricity was strongly biased because of systematic target-background contrast differences, but the four virtual

Table 4
*Spatial Gaze Variability (Square Degrees) Analysis of Variance With Repeated Measures:
 General Design, Process and Content Subdesign, and Both Live–Phone Subdesigns*

Source	MS (<i>df</i> = 1)	<i>F</i>	Cohen's <i>f</i>	MSE (<i>df</i> = 11)
General design				
Detection	940.19	9.86**	0.95	95.31
Task–no task				
Verbal abstract learning	939.18	5.71*	0.72	164.52
Verbal concrete learning	3,170.70	18.50**	1.30	171.38
Verbal abstract production	5,725.09	32.02**	1.71	178.82
Verbal concrete production	6,733.16	30.10**	1.65	223.71
Live Euro	8,052.95	59.93**	2.33	134.37
Phone Euro	9,970.91	43.51**	1.99	229.17
Live memory	6,577.64	24.89**	1.50	264.22
Phone memory	7,935.35	35.70**	1.80	222.27
Detection × Task				
Verbal abstract learning	49.17	0.13	0.11	367.59
Verbal concrete learning	893.73	3.12	0.53	286.49
Verbal abstract production	1,305.39	1.99	0.43	655.23
Verbal concrete production	427.12	3.41	0.56	125.37
Live Euro	705.78	4.40	0.63	160.57
Phone Euro	1,099.06	3.83	0.59	287.07
Live memory	822.17	2.80	0.45	587.90
Phone memory	1,316.05	2.24	0.50	293.31
Process and content subdesign				
Detection	6,973.02	10.61**	0.98	657.42
Content	256.87	3.28	0.55	78.34
Process	1,251.93	8.58*	0.88	145.99
Detection × Content	367.61	1.27	0.34	289.59
Detection × Process	2,195.12	4.27	0.62	514.21
Content × Process	92.85	2.47	0.47	37.60
Detection × Content × Process	13.76	0.03	0.05	440.25
Live–phone—Euro subdesign				
Detection	568.88	4.29	0.62	132.50
Version	51.17	0.99	0.30	51.90
Detection × Version	21.69	0.31	0.17	69.74
Live–phone—Memory subdesign				
Detection	406.08	0.90	0.29	452.62
Version	31.82	0.47	0.21	68.10
Detection × Version	28.91	0.20	0.14	142.09

Note. The general design analysis of variance was 2 (detection conditions) × 9 (mental tasks). Euro refers to the mental calculus task; memory refers to the autobiographic recall task.

* $p < .05$. ** $p < .01$.

targets were equalized in their conspicuity and differences in detectability could then be attributed to the eccentricity factor.

Therefore, in this section, we present the results only for the virtual spotlights, which are displayed in Figures 3–8. The results of the other subset of targets would neither add to nor invalidate the reported conclusions. Table 14 shows the ANOVA results. The mental tasks are not considered individually but as a whole, as in task versus no task. However, considering the purpose of this analysis—looking for a possible relation between detection, eccentricity, and task effects—the acquisition tasks were logically excluded, as they did not reveal any effects either in terms of gaze concentration, detection, or any other dependent measures.

With regard to detections (see Figure 3), there were differences due to task performance, but there was no significant interaction. Concerning correct responses (see Figure 4), no significant effect was found. Considering the percentage of glances at the targets (see Figure 5), there were statistically significant differences due to eccentricity and to task performance, but no interaction was observed. Regarding target perception time (see Figure 6), there were no significant effects. In inspection time (see Figure 7), significant differences could be attributed to task performance but not to eccentricity or interaction. Finally, there was a significant effect in decision time because of eccentricity but with no effect of task or interaction (see Figure 8).

Table 5
Speedometer Inspection (% Glances) Analysis of Variance With Repeated Measures: General Design, Process and Content Subdesign, and Both Live-Phone Subdesigns

Source	MS (df = 1)	F	Cohen's <i>f</i>	MSE (df = 11)
General design				
Detection	0.02	0.03	0.05	0.77
Task-no task				
Verbal abstract learning	9.63	5.46*	0.70	1.76
Verbal concrete learning	37.75	13.92**	1.12	2.71
Verbal abstract production	51.65	18.26**	1.29	2.83
Verbal concrete production	65.74	13.80**	1.12	4.76
Live Euro	70.92	17.97**	1.28	3.95
Phone Euro	73.38	20.94**	1.38	3.50
Live memory	47.22	5.79*	0.73	8.16
Phone memory	69.10	14.92**	1.16	4.63
Detection × Task				
Verbal abstract learning	1.35	0.25	0.15	5.40
Verbal concrete learning	17.25	4.71	0.65	3.66
Verbal abstract production	0.06	0.01	0.03	6.40
Verbal concrete production	0.50	0.09	0.09	5.60
Live Euro	5.30	3.18	0.54	1.67
Phone Euro	9.12	4.28	0.62	2.13
Live memory	0.00	0.00	0.00	17.70
Phone memory	5.79	2.64	0.49	2.20
Process and content subdesign				
Detection	0.17	0.03	0.05	5.98
Content	3.92	3.67	0.58	1.07
Process	9.14	6.31*	0.76	1.45
Detection × Content	3.91	1.13	0.32	3.48
Detection × Process	5.90	1.29	0.34	4.58
Content × Process	1.12	5.25*	0.69	0.21
Detection × Content × Process	1.03	0.37	0.18	2.78
Live-phone—Euro subdesign				
Detection	2.04	8.29*	0.87	0.25
Version	0.01	0.07	0.08	0.14
Detection × Version	0.26	0.72	0.26	0.36
Live-phone—Memory subdesign				
Detection	0.46	0.06	0.07	7.90
Version	1.04	0.73	0.26	1.42
Detection × Version	3.06	0.36	0.18	8.46

Note. The general design analysis of variance was 2 (detection conditions) × 9 (mental tasks). Euro refers to the mental calculus task; memory refers to the autobiographic recall task.

* $p < .05$. ** $p < .01$.

Therefore, although some of the processing indicators were related to target eccentricity, none of them revealed the interaction that would be expected according to the prediction of the tunnel vision hypothesis: The difference between task and no task would be more pronounced for higher eccentricities. Therefore, one can conclude that the deterioration in detection and response selection does not seem to be due to a tunnel vision effect but rather to a general interference phenomenon.

Discussion

This experiment was designed (a) to verify prior results of Recarte and Nunes (2000) and Recarte et al. (in press); (b) to

extend these results to study the effects of mental workload on detection and discrimination capacities; and (c) to increase the applied value of the mentioned studies by testing a set of different mental tasks, comparable to everyday activity that can lead to endogenous distraction, including a conversation with a hands-free phone or in live interactions with a passenger while driving.

In accordance with our expectations, the general results of previous findings were reproduced: Mental tasks produced incremented pupil size, indicating additional mental effort and spatial gaze concentration. The mirror- and speedometer-inspection reduction was also reproduced. The magnitudes of these effects were also similar to previous results (Recarte & Nunes, 2000).

Table 6
*Rearview Mirror Inspection (% Glances) Analysis of Variance With Repeated Measures:
 General Design, Process and Content Subdesign, and Both Live-Phone Subdesigns*

Source	MS (df = 1)	F	Cohen's <i>f</i>	MSE (df = 11)
General design				
Detection	0.01	0.07	0.08	0.19
Task-no task				
Verbal abstract learning	0.16	0.21	0.14	0.74
Verbal concrete learning	0.53	0.41	0.19	1.29
Verbal abstract production	7.63	11.43**	1.02	0.67
Verbal concrete production	2.04	2.02	0.43	1.01
Live Euro	9.52	22.55**	1.43	0.42
Phone Euro	16.91	20.98**	1.38	0.81
Live memory	14.05	18.11**	1.28	0.78
Phone memory	10.04	24.13**	1.48	0.42
Detection × Task				
Verbal abstract learning	0.06	0.02	0.04	3.01
Verbal concrete learning	0.04	0.02	0.04	2.06
Verbal abstract production	4.09	2.98	0.52	1.37
Verbal concrete production	0.00	0.00	0.01	1.30
Live Euro	1.16	0.83	0.27	1.40
Phone Euro	0.46	1.09	0.32	0.42
Live memory	0.15	0.16	0.12	0.89
Phone memory	0.60	0.39	0.19	1.53
Process and content subdesign				
Detection	0.16	0.24	0.15	0.68
Content	0.01	0.02	0.04	0.67
Process	3.71	4.99*	0.67	0.74
Detection × Content	1.03	0.66	0.25	1.56
Detection × Process	0.65	3.11	0.53	0.21
Content × Process	6.06	4.10	0.61	1.48
Detection × Content × Process	3.75	0.80	0.27	4.66
Live-phone—Euro subdesign				
Detection	0.18	1.97	0.42	1.00
Version	1.05	3.97	0.60	0.26
Detection × Version	0.77	2.61	0.49	0.30
Live-phone—Memory subdesign				
Detection	0.64	2.51	0.48	0.26
Version	0.34	1.23	0.33	0.27
Detection × Version	0.04	0.32	0.17	0.12

Note. The general design analysis of variance was 2 (detection conditions) × 9 (mental tasks). Euro refers to the mental calculus task; memory refers to the autobiographic recall task.

* $p < .05$. ** $p < .01$.

Considering different types of tasks, the results of Recarte et al. (in press) were also verified. Learning tasks (attending to audio messages) did not produce remarkable visual search changes. These learning tasks were rated as easy and, in fact, did not affect pupil size or spatial gaze concentration. Mirror and speedometer inspection were not affected or were only slightly affected, compared with the effects of production tasks. Last and most conclusively, in accordance with the results of the process and content subdesign, there were differences in almost all these variables when comparing the receptive learning tasks with tasks in which the participants had to reproduce the content of the audio message they had just heard.

With respect to the detection and response-selection capacities, the results indicate that the increased workload resulting from mental tasks produced endogenous distraction, affecting the capacity to process visual stimuli: When performing mental tasks, the percentages of detected targets and/or correct responses decreased significantly. It is of practical interest to point out as an example that some tasks showed a reduction in detection probability of almost 30% with respect to the control condition, something that is practically meaningful as an estimate of the increased risk of distraction errors hypothetically leading to traffic conflicts or accidents.

Regarding the interpretation of the relation between spatial gaze concentration attributable to mental tasks and detection capacity,

Table 7
Detected Targets (Percentage) Tasks × Participants Analysis of Variance: General Design, Process and Content Subdesign and Both Live–Phone Subdesigns

Source	<i>MS</i>	<i>df</i>	<i>F</i>	Cohen's <i>f</i>	<i>MSE</i>	<i>df</i>
General design						
Task	0.93	8	4.12**	0.61	0.23	88
Process and content subdesign						
Process	1.67	1	6.04*	0.79	0.28	11
Content	0.27	1	0.73	0.26	0.37	11
Process × Content	0.07	1	0.33	0.17	0.20	11
Live–phone—Euro subdesign						
Version	0.41	1	1.96	0.42	0.21	11
Live–phone—Memory subdesign						
Version	0.30	1	3.67	0.57	0.08	11

Note. Euro refers to the mental calculus task; memory refers to the autobiographic recall task.

* $p < .05$. ** $p < .01$.

these results pose a dilemma: Are spatial gaze concentration and detection impairment simply correlated variables or does visual search concentration cause the impairment of detection and decision-making capacities? According to the results, impairment of the detection task occurred independently of target eccentricity, and we concluded that, at least within the range of the tested eccentricity values and for the type of tested targets, no tunnel vision effect was produced. Therefore, we concluded that a general interference effect is produced by assigning attentional resources to the mental tasks (distraction) rather than as a consequence of a visual search change consisting of spatial gaze concentration, that is to say, a reduced visual inspection window.

There is evidence that part of the peripheral glances is dedicated to irrelevant objects in the landscape. Although not exclusively, spatial gaze concentration may be a positive and effective strategy

Table 8
Simple Contrasts With No Task for Detected Targets Tasks × Participants Analysis of Variance

Task	Difference	<i>SE</i>
VAL	−0.02	0.05
VCL	0.01	0.05
VAP	−0.22	0.05**
VCP	−0.12	0.05*
Live Euro	−0.22	0.05**
Phone Euro	−0.12	0.05*
Live memory	−0.10	0.05
Phone memory	−0.22	0.05**

Note. Euro refers to the mental calculus task; memory refers to the autobiographic recall task. VAL = verbal abstract learning; VCL = verbal concrete learning; VAP = verbal abstract production; VCP = verbal concrete production.

* $p < .05$. ** $p < .01$.

Table 9
Correct Responses (Percentage) Tasks × Participants Analysis of Variance: General Design, Process and Content Subdesign, and Both Live–Phone Subdesigns

Source	<i>MS</i>	<i>df</i>	<i>F</i>	Cohen's <i>f</i>	<i>MSE</i>	<i>df</i>
General design						
Task	0.28	8	2.39*	0.41	0.12	112.90
Process and content subdesign						
Process	0.19	1	2.59	0.40	0.07	16.53
Content	0.08	1	0.60	0.21	0.13	14.00
Process × Content	0.01	1	0.13	0.12	0.09	9.55
Live–phone—Euro subdesign						
Version	0.01	1	0.03	0.06	0.17	10.99
Live–phone—Memory subdesign						
Version	0.16	1	0.84	0.23	0.20	15.69

Note. Euro refers to the mental calculus task; memory refers to the autobiographic recall task.

* $p < .05$.

in an effort to focus the visual resource allocation on the most informative area of the visual field in statistical terms—the road ahead—and to cope with the increased workload imposed by an additional mental task. Although not due to endogenous increased workload, a comparable optimization of visual resources was described by Luoma (1986, 1988) in real driving conditions: When more relevant traffic targets were in the visual field, eye fixations on roadside advertisements (irrelevant peripheral objects) were significantly reduced in favor of traffic information. Despite this, the demands imposed by some mental tasks showed a negative balance that is revealed in the detection performance impairment.

The marked reduction in the speedometer and rearview mirrors inspection (also located in peripheral areas of the visual field) can be interpreted as a reduced situation awareness but also as an example of a balance to optimize visual resources, accepting that

Table 10
Simple Contrasts With No Task for Correct Responses Tasks × Participants Analysis of Variance

Task	Difference	<i>SE</i>
VAL	−0.01	0.05
VCL	0.04	0.05
VAP	−0.16	0.06*
VCP	−0.04	0.06
Live Euro	−0.12	0.06
Phone Euro	−0.08	0.06
Live memory	−0.13	0.06*
Phone memory	−0.19	0.06**

Note. Euro refers to the mental calculus task; memory refers to the autobiographic recall task. VAL = verbal abstract learning; VCL = verbal concrete learning; VAP = verbal abstract production; VCP = verbal concrete production.

* $p < .05$. ** $p < .01$.

Table 11
Glances to Targets (Percentage) Tasks × Participants Analysis of Variance: General Design, Process and Content Subdesign, and Both Live-Phone Subdesigns

Source	MS	df	F	Cohen's f	MSE	df
General design						
Task	1.76	8	7.27**	0.81	0.24	88
Process and content subdesign						
Process	2.40	1	6.29*	0.76	0.38	11
Content	0.15	1	0.54	0.22	0.28	11
Process × Content	0.02	1	0.08	0.08	0.22	11
Live-phone—Euro subdesign						
Version	0.30	1	1.74	0.40	0.17	11
Live-phone—Memory subdesign						
Version	0.08	1	1.94	0.42	0.04	11

Note. Euro refers to the mental calculus task; memory refers to the autobiographic recall task.
* $p < .05$. ** $p < .01$.

drivers can achieve an acceptable speed control with reduced speedometer inspection when they have no need to respect a particular speed limit restriction (Recarte & Nunes, 2002) and accepting that the relevance of mirrors inspection is strongly dependent of the traffic density and of drivers' self-paced intentions to perform changing lane maneuvers. Thus, although the magnitude of the reduction of speedometer and rearview mirrors inspection is statistically significant and very marked, its interpretation in practical terms is complex and exceeds the purpose of this article.

A more detailed analysis of the visual impairment is obtained from the analysis of the ocular responses to the detected targets. While performing mental tasks, the participants glanced at the targets less frequently, and a higher percentage of responses was given without foveal fixation.

Table 12
Simple Contrasts With No Task for Glances to Targets Tasks × Participants Analysis of Variance

Task	Difference	SE
VAL	-0.08	0.06
VCL	-0.05	0.06
VAP	-0.30	0.06**
VCP	-0.24	0.06**
Live Euro	-0.34	0.06**
Phone Euro	-0.22	0.06**
Live memory	-0.17	0.06**
Phone memory	-0.22	0.06**

Note. Euro refers to the mental calculus task; memory refers to the autobiographic recall task. VAL = verbal abstract learning; VCL = verbal concrete learning; VAP = verbal abstract production; VCP = verbal concrete production.
** $p < .01$.

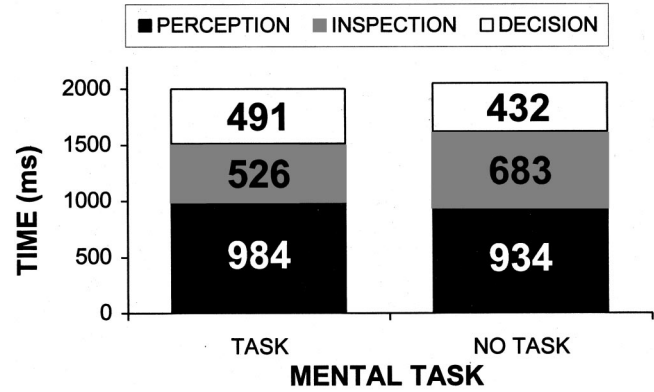

Figure 2. Total and partial response time stages—perception, inspection, and decision times (in milliseconds)—as a function of mental task performance (any task vs. no task).

Moreover, with mental tasks, the targets, if looked at, were detected later and glanced at for less time, although no delay was observed in response performance. Most of the responses were given after gazing at the targets and once the eyes were back on the road. Therefore, the target-to-road saccade seems to be the critical instant in which target information extraction is concluded and, presumably, the starting point to processing the decision rule.

The following sequence illustrates the way the glance at the target seems to be the relevant time lapse to obtain information and to identify its characteristics for the subsequent application of the decision rule. During target inspection time, a blink inhibition effect occurred: There were hardly any blinks at that time. At the end of the inspection time (when a saccade was made from the target to glance at somewhere on the road), a blink occurred simultaneously with this saccade in more than 25% of the cases, which provides additional evidence for the inhibition effect and suggests an information-processing economy routine of our visual system: Under increased demand conditions, two ocular responses, saccade and blink (in which no useful visual information can be

Table 13
Total Response Time Partition in Perception Time, Inspection Time, and Decision Time: Task–No Task × 3 Times Multivariate Analysis of Variance

Source	MS	df	F	Cohen's f
Perception time				
Task	1,735,846.43	1	5.15*	0.11
Error	337,334.57	456		
Inspection time				
Task	2,703,439.71	1	27.72**	0.25
Error	97,539.18	456		
Decision time				
Task	433,028.18	1	2.20	0.07
Error	197,093.65	456		

* $p < .05$. ** $p < .01$.

Table 14
Effects of Eccentricity and Task on Detected Targets, Correct Responses, Glances to Targets, Perception Time, Inspection Time, and Decision Time: Eccentricity × Tasks Analysis of Variance

Source	MS	df	F	Cohen's f
Detected targets				
Eccentricity	1.50	3	7.54**	0.26
Task	2.05	1	10.35**	0.18
Eccentricity × Task	0.43	3	2.18	0.14
Error	0.20	327		
Correct responses				
Eccentricity	0.01	3	0.10	0.04
Task	0.24	1	1.90	0.09
Eccentricity × Task	0.09	3	0.70	0.10
Error	0.13	220		
Glances to targets				
Eccentricity	1.39	3	6.52**	0.24
Task	3.51	1	16.44**	0.22
Eccentricity × Task	0.30	3	1.40	0.11
Error	0.21	327		
Perception time				
Eccentricity	608,580.35	3	1.56	0.16
Task	140,163.34	1	0.36	0.04
Eccentricity × Task	275,504.08	3	0.70	0.11
Error	391,245.43	183		
Inspection time				
Eccentricity	299,608.83	3	2.17	0.19
Task	1,087,896.40	1	7.87**	0.20
Eccentricity × Task	85,635.50	3	0.62	0.10
Error	138,318.37	188		
Decision time				
Eccentricity	1,229,813.89	3	4.76**	0.28
Task	189,406.15	1	0.73	0.06
Eccentricity × Task	289,484.06	3	1.12	0.13
Error	258,241.22	188		

** $p < .01$.

extracted), are simultaneously combined in a single move as a means to gain time. Accepting the information-acquisition function of the inspection time and from the analysis of the effects of mental tasks on the different time stages, we conclude that the errors derive from deficient target perception and/or identification rather than from the application of the decision rule and/or response performance. According to our results, the targets were glanced at later, less frequently, and inspected for less time while performing a mental task, whereas the decision times remained unaffected. Of course, in this research, the response performance itself was quite a simple task and the decision rule was limited to a choice between two alternatives. One could expect that if the response involved more complex decision rules or an intrinsic response performance difficulty, then those stages would be affected. When driving, many decisions are choices between two

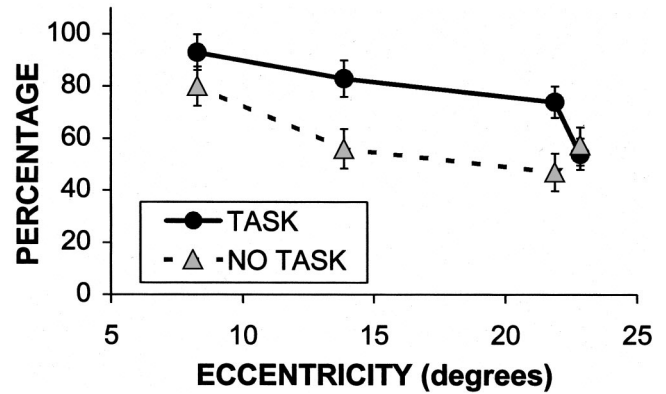

Figure 3. Detected targets as a function of eccentricity and mental task performance (any task vs. no task): percentage among the subset of the four virtual targets (reflection beams).

alternatives, although other decisions are more complex. Elementary actions, such as pressing or releasing the accelerator and braking or not braking, and higher level decisions, such as braking or swerving and overtaking or not overtaking, are examples of two-choice real-life situations. For a trained driver, the response performance itself is highly automated in many of these cases. Therefore, the predicted effect of endogenous distraction on the perception and discrimination processes is justified, although we should not exclude the probability that the decision stages could suffer a serious impairment in critical situations requiring complex decisions and/or responses.

In conclusion, under the increased attentional load imposed by several mental tasks, the drivers made some effort to optimize their visual resources. However, despite this, some tasks caused interference, affecting the processing of visual information and, in particular, the detection and discrimination capacities. Let us see what happens with different tasks.

Considering the process and content subdesign, only tasks that involve verbal response production seem to produce effects on visual search and on detection and response-selection capacities.

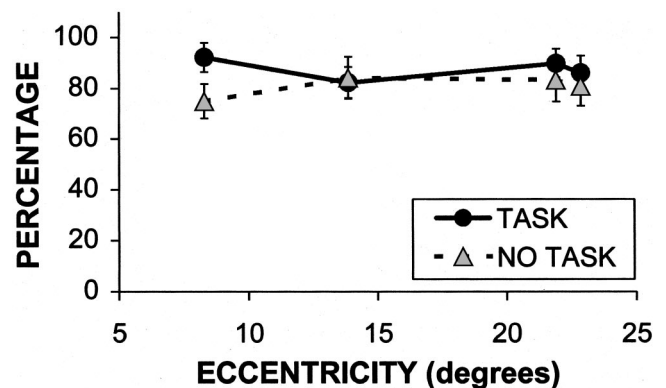

Figure 4. Correct discrimination responses as a function of eccentricity and mental task performance (any task vs. no task): percentage among the detected targets within the subset of the four virtual targets (reflection beams).

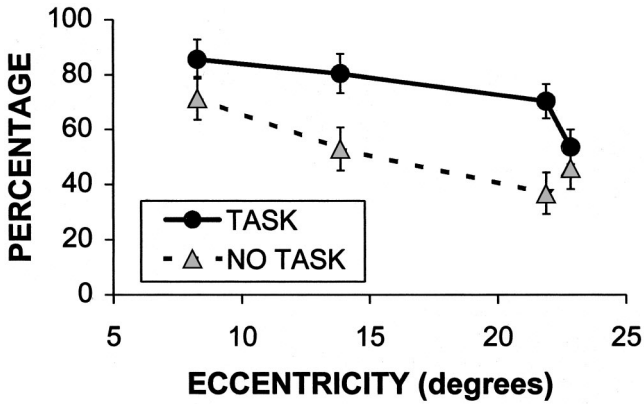

Figure 5. Glanced-at targets as a function of eccentricity and mental task performance (any task vs. no task): percentage among the detected targets within the subset of the four virtual targets (reflection beams).

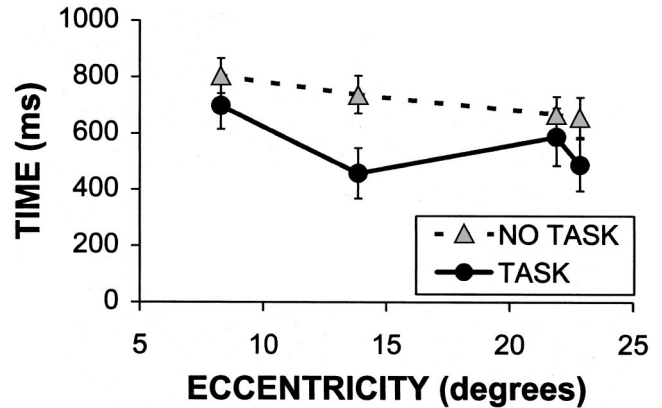

Figure 7. Inspection time (in milliseconds) for the glanced-at and detected targets among the four virtual targets (reflection beams) as a function of eccentricity and mental task performance (any task vs. no task).

Tasks that were limited to attending to incoming verbal information, such as listening to the radio or to another person, did not affect visual behavior, detection, or decision-making processes. It seems that receiving information while driving, at least in the case of neutral audio messages (with no emotional connotations) and with no need to perform an immediate action, has little opportunity to produce distraction. In our opinion, the audio messages were low in demand because of the high redundancy of the common verbal language: Syllables, words, syntax, and semantic context allow one to adequately process the content of this information by means of a time-sharing sampling strategy, alternating attention to the message and to the driving task, which, on many occasions, is not particularly demanding. In contrast, it is evident that in the early acquisition processing stages, simultaneous visual and audio input information cannot mutually interfere because of structural reasons and that, regarding further processing stages, from a specific resource perspective (Wickens, 1984, 1992), some audio-verbal information might at least be partially processed in parallel with visual-spatial information and thus with no interference. However, comparing dual task and single task, some recent results

on neuropsychological correlates of mental activity suggest that attention should be understood as a central and unspecific process (Just et al., 2001). However, independently of the theoretical explanation, the obtained results are of practical interest for the evaluation of the potential impact of in-car devices, the improvement of intelligent vehicle-user interfaces, and the issue of how to present information to drivers with minimal interference: by visual displays, audio messages, or other means. Despite the apparent advantage of audio messages, it is difficult to predict which verbal messages might or might not be a source of distraction without empirical testing. In practical terms, the experimental conditions tested seem more comparable to listening to a radio program, for example, but they did not include messages containing information expressly relevant for the driving task or that involved an immediate response. If message redundancy is the reason for the lack of effect, then short messages with little redundancy have more opportunities to cause problems, particularly if the information provided is relevant. Otherwise, visual information on a display (such as a simple pictogram showing the next roundabout exit) can, in a short time lapse, provide information content that might

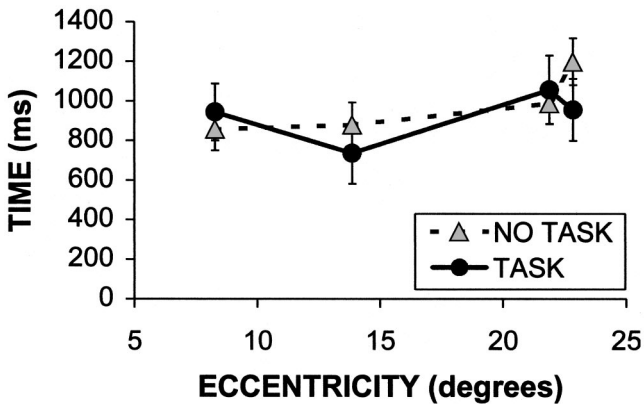

Figure 6. Perception time (in milliseconds) for the glanced-at and detected targets among the four virtual targets (reflection beams) as a function of eccentricity and mental task performance (any task vs. no task).

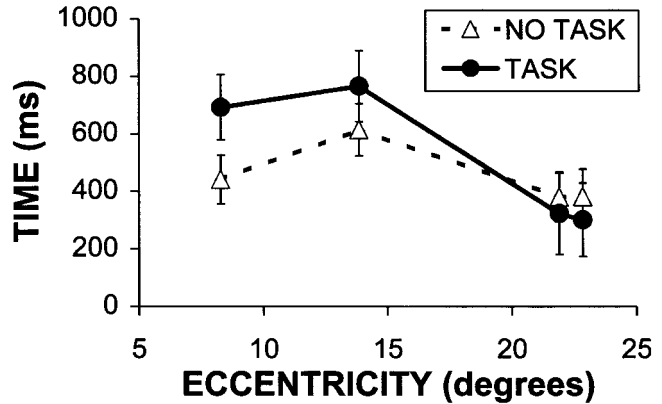

Figure 8. Decision time (in milliseconds) for the glanced-at and detected targets among the four virtual targets (reflection beams) as a function of eccentricity and mental task performance (any task vs. no task).

need a considerably longer time to be transmitted and processed if presented in an equivalent audio version. In our opinion, although our results were solidly replicated in two experiments, the issue of the different effects produced by information acquisition versus production processes requires more research to be well understood.

With regard to the study of the hands-free phone conversation, a series of null results appears. However, these null results do not represent a simple lack of effect but rather the presence of similar observed effects in different task versions: Mental calculus and autobiographic recall showed clear effects on visual behavior and on the detection task, but when comparing phone and live versions, the same effects are produced, and no differences were found between versions. The hands-free phone conversation does not seem to produce any additional effects other than those produced by the messages being processed. Considering the 16 data of power (8 for euro task and 8 for memory task) calculated for the effect of the version conditions (live vs. phone), we find power values varying from 0.05 for pupil size with euro task to 0.66 in subjective effort rating for memory, with a median of 0.18, which means that the probability of error if accepting the null hypothesis in each of the comparisons is high. However, two arguments should also be considered that give more strength to the interpretation in favor of the equivalence between live and phone versions: (a) The lack of significant differences occurred in all the 16 comparisons made, with no exception, and (b) in the case of accepting that the difference between versions exists, its magnitude appears to be very low compared with the magnitude of the effects attributable to tasks.

Given the debate raised by the use of the phone, it is important to state that our study focused exclusively on the conversation effect, explicitly excluding phone-manipulation operations, such as dialing or navigating through the phone menu. With regard to this, the hands-free phone conversation seems comparable to talking to a passenger: The potential distraction is related to the attentional load imposed by the conversation complexity. Nevertheless, as has been observed by Parkes (1991), phone tasks were systematically rated as more effortful than their equivalent live versions. Parkes attributed this difference to the self-paced rhythm of live conversation as opposed to the more continuous expectations on the phone conversation rhythm: Live conversations can be interrupted at any time if driving demands arise, and, presumably, passengers can cooperate; in phone conversations, the lack of face-to-face feedback and the interlocutor's lack of information about the surrounding traffic does not allow this adaptive cooperation between interlocutors (McKnight & McKnight, 1993), which can lead to moments of higher cognitive demand when talking over the phone (Haigney & Westerman, 2001). However, this advantage from a cooperative passenger could also become more problematic with a careless or aggressive passenger: In this case, the psychological distance imposed by the phone could be of use. We should like to emphasize two relevant aspects regarding the phone: (a) The hands-free phone combined with voice-operated dialing is a technological solution that makes telephoning comparably as safe as normal live conversation, and (b) complex conversations involving demanding mental tasks are potentially dangerous, whether by phone or in live conversation. As tested in other experiments (Nunes & Recarte, 2002), low-demand phone or live conversations can be regarded as safe, as they do not affect the visual capacities. The complexity of the message is what matters.

Taking into account that a conversation of complex content can be a source of distraction, the presence in some buses of the familiar warning sign "Don't talk to the driver" seems logical. However, in the light of the results from the comparison of reception and production tasks, this warning could be more precisely expressed as "Don't make the driver talk" or "The driver is not allowed to talk."

As a final remark concerning the validity of the criteria used to test the visual-detection and response-selection capacities for the driving task, as already pointed out, flashing lights are usually meaningful events in traffic environments and similar procedures have been used in other experiments reported in the literature. Nevertheless, it is obvious that they do not have real meaning, as in the case of a turning signal or a yellow flashing traffic light. Our experimental targets acquire meaning only because of the experimenter's instructions. In consequence, one could expect that they could easily be ignored if a relevant traffic situation cropped up or if the participant eventually assigned higher priority to the mental task than to the detection task. This is the cost of using artificial stimuli instead of real threatening and unexpected traffic events that require real meaningful avoiding actions instead of pressing buttons. Perhaps such threatening traffic events could be adequately tested in a simulated environment, although the lack of real risk could also affect the priority assigned to those events by increasing the probability of missing them.

However, from another perspective, the results of the detection task could lead to underestimation of the practical value of the results: At the beginning of the experiment, participants were instructed and warned about the targets, and this produced a mental set for detecting them. Although there was an unexpected component regarding their temporal and spatial uncertainty, the targets were, to some extent, expected events. If drivers may have some expectations about where some hazardous events may appear, other traffic events are much more unpredictable than the experimental stimuli. This would amplify the observed impairment of detection capacities due to endogenous distraction, hence, the potential hazard of mental tasks to produce errors when processing relevant traffic visual stimuli.

Despite the differences and similarities between experimental stimuli and natural traffic events, it seems clear that the attentional processes affected by distraction show similarities in both cases: Performance of mental tasks prevents application of top-down processes. This processing impairment is also implicit in statements given by drivers who were involved in accidents: "I didn't expect it," "I looked but failed to see," or "I saw it too late."

Given that mental activity alters the strategies of visual information acquisition while driving (Recarte & Nunes, 2000), this research showed that mental activity can also affect processing capacities in terms of detection, discrimination, and response selection. Moreover, the research provides empirical evidence suggesting a plausible interpretation of the spatial gaze concentration as an adaptive visual attentional strategy when driving, as opposed to the widely extended tendency to identify gaze concentration with tunnel vision. Methodologically, the interpretation of the visual search changes was particularly fruitful, thanks to the use of mental tasks involving no explicit foveal load as a means to increase the attentional load instead of other relevant variables, such as traffic complexity. The attempt to isolate different effects of different types of mental tasks has produced some relevant

results in the comparison of acquisition and production processes, although this is far more difficult to generalize to real-life tasks. Considering the quantitative dimension of attentional effort and mental task difficulty, our research shows that the observed effects are sensitive to mental effort, and we confirmed, once more, that even with the daylight variations of a natural environment, pupil size can be used as a reliable objective indicator of mental effort, at least if there is a significantly large amount of collected data.

The contribution to the comprehension of attentional processes in the driving context is of particular relevance for the improvement of in-vehicle or on-the-road man-machine interfaces. The relative weight of the visual resources dedicated to inspecting the mirrors and the speedometer under various task demands and the results of the hands-free phone subdesign provide useful information for practical issues such as evaluation, legislation, and technical improvement.

Regarding the practical significance of mental tasks as potential distractors, one could stress that the risk of endogenous distraction is at least as relevant as exogenous distraction. It seems important to stress that distraction cannot be directly submitted to surveillance and enforcement. Safety measures, such as removing potential external distractors or restricting the use of in-vehicle devices to reduce occasions for distraction, could be effective if users and legislators feel committed to the importance of attentional control for road safety. Otherwise, such measures can easily become ineffective because of a behavioral adaptation effect: Removing distractors from the road or from the vehicle can be compensated by alternative endogenous distraction if drivers underestimate the importance of attention and the risk of distraction, including their own mental activity when driving.

References

- Bossi, L. L., Ward, N. J., Parkes, A. M., & Howarth, P. A. (1997). The effect of vision enhancement systems on driver peripheral visual performance. In Y. I. Noy (Ed.), *Ergonomics and safety of intelligent driver interfaces* (pp. 239–260). Mahwah, NJ: Erlbaum.
- Cohen, J. (1988). *Statistical power analysis for the behavioral sciences*. Hillsdale, NJ: Erlbaum.
- Crundall, D. E., & Underwood, G. (1998). Effects of experience and processing demands on visual information acquisition in drivers. *Ergonomics*, *41*, 448–458.
- Gottlieb, W., Scherbarth, S., & Guse, K. (1996). New scientific instrument for vision in vehicles research. In A. G. Gale, I. D. Brown, C. M. Haslegrave, & S. P. Taylor (Eds.), *Vision in vehicles V* (pp. 203–210). Amsterdam: North-Holland.
- Haigney, D., & Westerman, S. J. (2001). Mobile (cellular) phone use and driving: A critical review of research methodology. *Ergonomics*, *44*, 132–143.
- Heuer, H. (1996). Dual-task performance. In O. Newman & A. F. Sanders (Eds.), *Handbook of perception and action. Vol. 3. Attention* (pp. 113–153). London: Academic Press.
- Holmes, D. L., Cohen, K. M., Heith, M. M., & Morrison, F. J. (1977). Peripheral visual processing. *Perception and Psychophysics*, *22*, 571–577.
- Huges, P. K., & Cole, B. L. (1988). The effect of attentional demand on eye-movement behavior when driving. In A. G. Gale, M. H. Freeman, C. M. Haslegrave, P. Smith, & S. P. Taylor (Eds.), *Vision in vehicles II* (pp. 221–230). Amsterdam: Elsevier (North-Holland).
- Just, M. A., Carpenter, P. A., Keller, T. A., Emery, L., Zajac, H., & Thulborn, K. R. (2001). Interdependence of non-overlapping cortical systems in dual cognitive tasks. *NeuroImage*, *14*, 417–426.
- LaBerge, D. (1995). *Attentional processing: The brain's art of mindfulness*. Cambridge, MA: Harvard University Press.
- Lee, P. N. J., & Triggs, T. J. (1976). The effect of driving demand and roadway environment on peripheral visual detections. *Proceedings of the 8th Conference of the Australian Road Research Board*, 7–12.
- Luoma, J. (1986). *The acquisition of visual information by the driver: Interaction of relevant and irrelevant information* (Report No. 32). Finland: Likkenneturva (The Central Organization for Traffic Safety).
- Luoma, J. (1988). Drivers' eye fixations and perceptions. In A. G. Gale, M. H. Freeman, C. M. Haslegrave, P. Smith, & S. P. Taylor (Eds.), *Vision in vehicles II* (pp. 231–237). Amsterdam: Elsevier (North-Holland).
- Mack, A., & Rock, I. (1998). Inattention blindness: Perception without attention. In R. D. Wright (Ed.), *Visual attention* (pp. 55–76). New York: Oxford University Press.
- McKnight, A. J., & McKnight, A. S. (1993). The effect of cellular phone use upon driver attention. *Accident Analysis and Prevention*, *25*, 259–265.
- Miura, T. (1990). Active function of eye movement and useful field of view in a realistic setting. In R. Groner, G. d'Ydewalle, & R. Parham (Eds.), *From eye to mind: Information acquisition in perception, search and reading* (pp. 119–117). Amsterdam: Elsevier (North-Holland).
- Moray, N. (1993). Designing for attention. In A. Baddeley & L. Weiskrantz (Eds.), *Attention: Selection, awareness, and control* (pp. 111–134). Oxford, England: Clarendon Press.
- Nunes, L. M., & Recarte, M. A. (1997). Argos program: Development of technological systems and research programs for driver behavior analysis under real traffic conditions. In P. Albuquerque, J. A. Santos, C. Rodrigues, & A. H. Pires daCosta (Eds.), *Human factors in road traffic II* (pp. 154–159). Braga, Portugal: Universidade do Minho.
- Nunes, L. M., & Recarte, M. A. (2002). Cognitive demands of hands-free-phone conversation while driving. *Transportation Research*, *5*, 133–144.
- Parkes, A. M. (1991). Drivers' business decision-making ability whilst using car phones. In E. Lovessey (Ed.), *Contemporary ergonomics: Proceedings of the Ergonomic Society annual conference* (pp. 427–432). London: Taylor & Francis.
- Pashler, H., & Johnston, J. C. (1998). Attentional limitations in dual-task performance. In H. Pashler (Ed.), *Attention* (pp. 155–189). East Sussex, UK: Psychology Press.
- Pashler, H., Johnston, J. C., & Ruthruff, E. (2001). Attention and performance. *Annual Review of Psychology*, *52*, 629–651.
- Posner, M. L. (1980). Orienting of attention. *Quarterly Journal of Experimental Psychology*, *32*, 3–25.
- Pottier, A. (1999). Evaluation of functional fields of view in the real driving situation. In A. G. Gale, I. D. Brown, C. M. Haslegrave, & S. R. Taylor (Eds.), *Vision in vehicles VII* (pp. 233–241). Amsterdam: Elsevier (North-Holland).
- Rantanen, E. M., & Goldberg, J. H. (1999). The effect of mental workload on the visual field size and shape. *Ergonomics*, *42*, 816–834.
- Rayner, K. (1998). Eye movements in reading and information processing: 20 years of research. *Psychological Bulletin*, *134*, 372–422.
- Recarte, M. A., & Nunes, L. M. (2000). Effects of verbal and spatial-imagery task on eye fixations while driving. *Journal of Experimental Psychology: Applied*, *6*, 31–43.
- Recarte, M. A., & Nunes, L. M. (2002). Mental load and loss of control over speed in real driving. Towards a theory of attentional speed control. *Transportation Research*, *5*, 111–122.
- Recarte, M. A., Nunes, L. M., & Conchillo, A. (in press). Attention and eye-movements while driving: Effects of verbal versus spatial-imagery and comprehension versus response production tasks. In A. G. Gale, I. D. Brown, C. M. Haslegrave, & S. P. Taylor (Eds.), *Vision in vehicles VIII*. Amsterdam: Elsevier. (North-Holland).
- Rumar, K. (1990). The basic driver error: Late detection. *Ergonomics*, *33*, 1281–1290.

- Sanders, A. F. (1998). *Elements of human performance. Reaction processes and attention in human skill*. Mahwah, NJ: Erlbaum.
- Sanders, A. F., & Donk, M. (1996). Visual search. In O. Newman & A. F. Sanders (Eds.), *Handbook of perception and action. Vol. 3. Attention* (pp. 43-77). London: Academic Press.
- Summala, H., Nieminen, T., & Punto, M. (1996). Maintaining lane position with peripheral vision during in-vehicle tasks. *Human Factors*, 38, 442-451.
- Theeuwes, J. (1996). Visual search at intersections: An eye movement analysis. In A. G. Gale, I. D. Brown, C. M. Haslegrave, & S. P. Taylor (Eds.), *Vision in vehicles V* (pp. 125-134). Amsterdam: Elsevier (North-Holland).
- Theeuwes, J., & Godijn, R. (2001). Attentional and oculomotor capture. In C. Folk & B. Gibson (Eds.), *Attraction, distraction, and action: Multiple perspectives on attentional capture* (pp. 121-149). Amsterdam: Elsevier.
- Titchener, E. B. (1908). *Lectures on the elementary psychology of feeling and attention*. New York: Macmillan.
- Van der Weijger, E. C. M., & Van der Kloek, G. M. J. (1999). Parallel processing and interference in simultaneous foveal and peripheral task performance. In A. G. Gale, I. D. Brown, C. M. Haslegrave, & S. R. Taylor (Eds.), *Vision in vehicles VII* (pp. 73-81). Amsterdam: Elsevier. (North-Holland).
- Von Helmholtz, H. (1924). *Treatise on physiological optics*. Rochester, NY: Optical Society of America.
- Wickens, C. D. (1984). Processing resources in attention. (In R. Parasuraman & R. Davies (Eds.), *Varieties of attention* (pp. 63-102). New York: Academic Press.
- Wickens, C. D. (1992). *Engineering psychology and human performance* (2nd ed.). New York: Harper & Row.
- Williams, L. J. (1985). Tunnel vision induced by foveal load manipulation. *Human Factors*, 27, 221-227.
- Williams, L. J. (1988). Tunnel vision or general interference? Cognitive load and attentional bias are both important. *American Journal of Psychology*, 101, 171-191.
- Wright, R. D., & Ward, L. M. (1998). The control of visual attention. In R. D. Wright (Ed.), *Visual attention* (pp. 132-186). New York: Oxford University Press.
- Yantis, S., & Jonides, J. (1984). Abrupt visual onset and selective attention: Evidence from visual search. *Journal of Experimental Psychology: Human Perception and Performance*, 10, 601-621.

Received May 30, 2002

Revision received March 18, 2003

Accepted March 18, 2003 ■

ORDER FORM

Start my 2003 subscription to the *Journal of Experimental Psychology: Applied!* ISSN:1076-898X

_____ \$33.00, APA MEMBER/AFFILIATE _____
 _____ \$66.00, INDIVIDUAL NONMEMBER _____
 _____ \$157.00, INSTITUTION _____
 in DC add 5.75% / In MD add 5% sales tax _____
TOTAL AMOUNT ENCLOSED \$ _____

Subscription orders must be prepaid. (Subscriptions are on a calendar year basis only.) Allow 4-6 weeks for delivery of the first issue. Call for international subscription rates.



AMERICAN
PSYCHOLOGICAL
ASSOCIATION

SEND THIS ORDER FORM TO:
 American Psychological Association
 Subscriptions
 750 First Street, NE
 Washington, DC 20002-4242

Or call (800) 374-2721, fax (202) 336-5568.
 TDD/TTY (202) 336-6123.
 For subscription information, e-mail:
 subscriptions@apa.org

Send me a FREE Sample Issue

Check enclosed (make payable to APA)

Charge my: VISA MasterCard American Express

Cardholder Name _____

Card No. _____ Exp. Date _____

 Signature (Required for Charge)

BILLING ADDRESS: _____

City _____ State _____ Zip _____

Daytime Phone _____

SHIP TO:

Name _____

Address _____

City _____ State _____ Zip _____

APA Member # _____ XAPA13