

Metal contact reliability of RF MEMS switches

Qing Ma, Quan Tran, Tsung-Kuan A. Chou, John Heck, Hanan Bar, Rishi Kant and Valluri Rao
Intel Corporation, Santa Clara, CA 95054

ABSTRACT

It is well-recognized that MEMS switches, compared to their more traditional solid state counterparts, have several important advantages for wireless communications. These include superior linearity, low insertion loss and high isolation. Indeed, many potential applications have been investigated such as Tx/Rx antenna switching, frequency band selection, tunable matching networks for PA and antenna, tunable filters, and antenna reconfiguration. However, none of these applications have been materialized in high volume products to a large extent because of reliability concerns, particularly those related to the metal contacts. The subject of the metal contact in a switch was studied extensively in the history of developing miniaturized switches, such as the reed switches for telecommunication applications. While such studies are highly relevant, they do not address the issues encountered in the sub 100 μ N, low contact force regime in which most MEMS switches operate. At such low forces, the contact resistance is extremely sensitive to even a trace amount of contamination on the contact surfaces. Significant work was done to develop wafer cleaning processes and storage techniques for maintaining the cleanliness. To preserve contact cleanliness over the switch service lifetime, several hermetic packaging technologies were developed and their effectiveness in protecting the contacts from contamination was examined. The contact reliability is also very much influenced by the contact metal selection. When pure Au, a relatively soft metal, was used as the contact material, significant stiction problems occurred when clean switches were cycled in an N₂ environment. In addition, various mechanical damages occurred after extended switching cycling tests. Harder metals, while more resistant to deformation and stiction, are more sensitive to chemical reactions, particularly oxidation. They also lead to higher contact resistance because of their lower electrical conductivity and smaller real contact areas at a given contact force. Contact reliability issues could also be tackled by improving mechanical designs. A novel collapsing switch capable of generating large contact forces (>300 μ N) was shown to be less vulnerable to contamination and stiction.

Keywords: MEMS switch, contact, reliability

1. INTRODUCTION

One of the most exciting areas of MEMS research is RF MEMS for the vast and growing wireless communication applications. An increasingly evident trend is the integration of multi-mode radio in a single appliance, such as a cell phone [1]. For example, many cell phones have several GSM or CDMA bands plus Bluetooth. More recently, serious efforts have been announced to incorporate WLAN/WiMAX in handheld devices. Integration of more radios is not, however, without significant challenges. As one puts more and more parallel systems in a limited space, the form factor and cost of the increasing number of components must be reduced drastically and continuously. This is hardly a sustainable trend because many of these components are analog in nature and therefore not particularly scalable. In addition, multiple systems in close proximity cause significant interference problems. To address these challenges, various new architectures have been investigated to combine several systems into a single radio. The so-called agile radio can jump from one radio protocol to another seamlessly according to changes of user applications and environments. While transceivers are inherently programmable, the RF front-end, consisting of passive networks, must also be reconfigurable in real time in order for the whole system to be switchable from one frequency band to another as instructed by the system. A generic reconfigurable RF front-end with a reconfigurable antenna is illustrated in Fig. 1. A reconfigurable antenna can have many possible features. A narrow band antenna that can be switched to the desired frequency band is much more efficient than a broad band antenna covering the whole bandwidth of interest. This can be achieved by tuning MEMS varactors or by selecting the correct capacitors from a capacitor bank using MEMS switches. Another feature is beam steering – modulating the phase of multiple radiation elements so their emissions have constructive interference in the user directions. A tunable matching network is generally required to match the changing impedance of the antenna to the RF front-end. After the antenna, a complicated filter system follows.

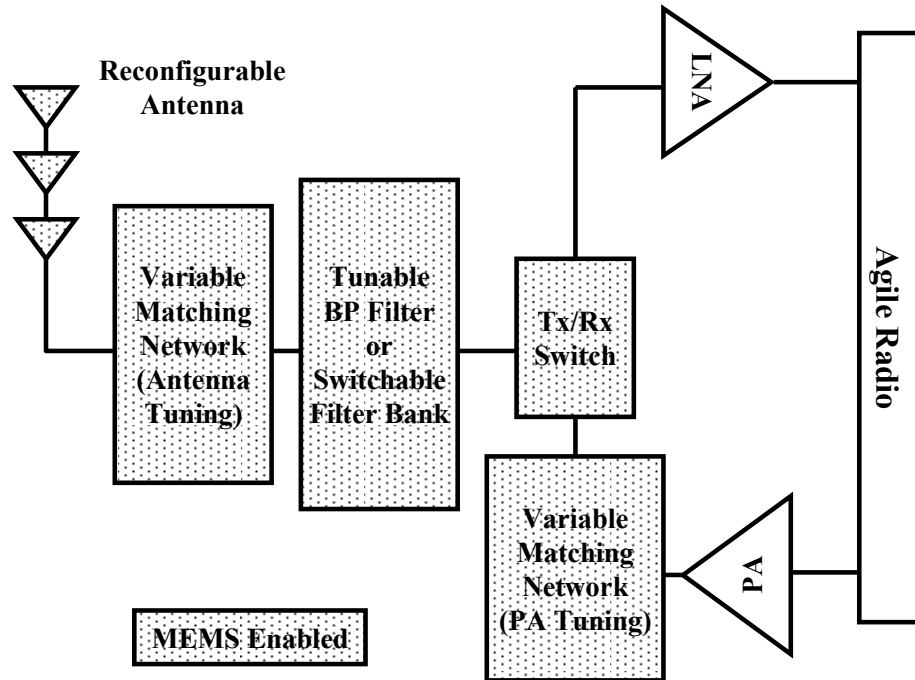

Figure 1. Reconfigurable RF front-end for Agile Radio. RF MEMS devices, particularly switches, are ideal for reconfiguration of passive RF circuits.

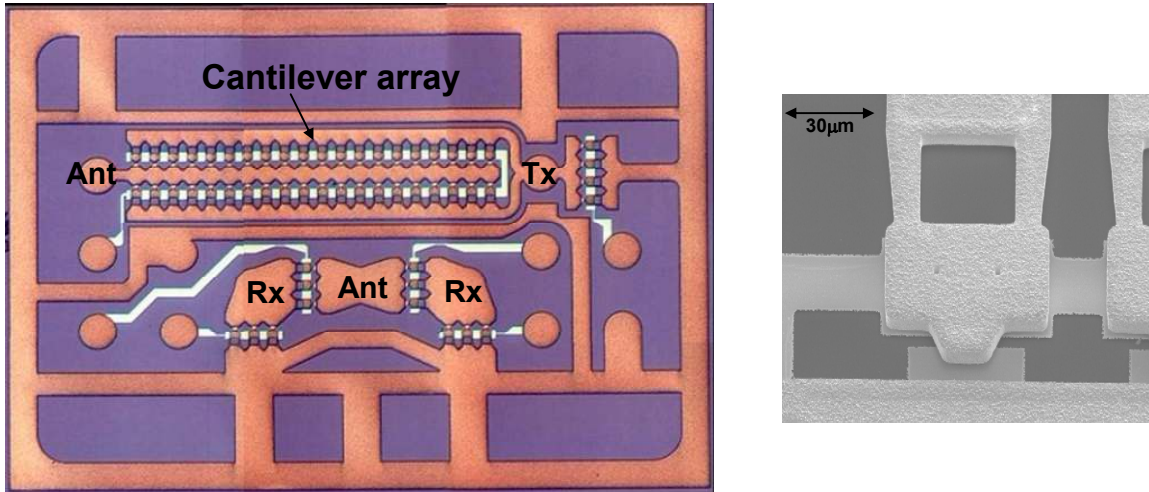

Figure 2. Example of a Tx/Rx switch module. The optical image on the left shows the whole module with the Tx switch consisting of many individual cantilever switches. The SEM micrograph on the right shows a cantilever switch.

High quality filters using SAW or FBAR technologies are generally required for cellular bands. LC filters are more suitable for the WLAN/WiMAX bands which are significantly broader. MEMS switches can be used to select the proper filters or to reconfigure a filter to a specific frequency band in real time. Sometimes, additional notch filters must be switched into the network to reduce interference. With the exception of CDMA, a Tx/Rx switch is needed to connect the filters to the PA on the transmission side or the LNA on the receiving side. Figure 2 shows such a MEMS Tx/Rx switch module in which many individual cantilever switches are in a parallel array to handle the transmission power.

Finally, it is highly desirable to share a single PA among all of the frequency bands. The impedance matching network must be tuned to the frequency of the signal in order for the PA to function properly.

While reconfigurable RF front-end and reconfigurable antennas are essential for agile radio applications, such reconfigurability is best achieved by using MEMS switches from the performance point of view. Table 1 compares several key parameters between solid state switches and MEMS contact switches. The ultra-low insertion loss achieved by MEMS switches is critical for power efficient signal reception/transmission because the signal passes through many switches between the antenna and RFIC. Improved isolation from MEMS switches enables better filtering and less interference. Because many switches are used, any noise generated due to non-linearity could compound into unacceptable levels. Only metal contact switches are addressed here because for the frequency range of interest (<10 GHz), metal contact switches generally perform better than capacitive switches.

Table 1. Performance comparison between solid-state switches and MEMS switches for RF applications.

	Insertion Loss (dB)	Isolation (dB)	Linearity (dBm)	Peak power (W)	Power consumption	Speed (μ s)
SS Switch	~ 0.5	~ - 25	~ - 40	~ 2	~ 5 mW	< 0.1
MEMS Switch	~ 0.1-0.2	~ - 35	~ - 65	~ 2	~ 10 μW	< 10

Despite the well recognized performance advantages of MEMS switches, no widespread applications have been materialized, to a large extent, because of reliability concerns including actuation voltage change caused by dielectric charging and cantilever beam structural deformation, leaking of hermetic packaging and metal contact degradation. Among all the reliability issues, those related to the metal contacts are the most challenging. The reliability of metal contacts was the topic of intense study for decades during the development of miniature relays for telecommunication and other applications [2-6]. One solution was using mercury wetted self-replenished contacts, which can last $\sim 10^9$ - 10^{10} switching cycles [4]. Dry reed switches achieved similar lifetime by using specialized alloys as contact materials and highly clean hermetic glass encapsulation [5]. While the knowledge accumulated for these miniature switch contacts is highly valuable, they do not necessarily address the unique issues encountered by MEMS switches. This is because electromagnetically actuated miniature switches operate with contact forces orders of magnitude higher than contact forces $< 100\mu$ N typically afforded by electrostatic actuation in MEMS switches. At such low contact forces, even a partial monolayer of surface contaminants could raise the contact resistance dramatically, because the metal tip could not penetrate the contamination layer [7]. In this paper, we report investigations of contact degradation and reliability issues, describe solutions in wafer processing, cleaning and packaging that are proven to be effective, and discuss material selection and mechanical design considerations for long term reliability.

2. METAL CONTACT RELIABILITY

2.1 Typical processing flow

To facilitate later discussions, a simplified switch fabrication flow is provided in Fig. 3. Briefly, the bottom electrode (Au) and a contact metal layer is deposited and patterned on a dielectric layer on silicon. Then the sacrificial layer is deposited and patterned. Note that a small recessed area is etched for the contact dimple. This is achieved either by etch time control or by using two sacrificial layers where a hole is etched through the first layer which determines the dimple height. The top contact metal (also serves as the plating seed layer) is deposited and a thick layer of plating mold resist is spun and patterned. Finally, Au is plated to form the cantilever beam and the transmission lines, the mold is removed, the extra seed layer is etched away, and the switch is released by dissolving the sacrificial layer.



Figure 3. Switch process flow. (a) Deposition and patterning of bottom electrode and bottom contact metal. (b) Deposition and patterning of sacrificial layer with a small recess area for contact dimple formation. (c) Deposition of top metal contact metal which also serves as plating seed layer. Deposition and patterning of thick plating mold resist. (d) Plating cantilever beam, etching of excess seed layer and removing sacrificial layer to release the beam.

2.2 Surface cleanliness

During the development of the switch process, contact resistance/insertion loss was used as a key parameter for optimization. Initially, large contact resistance of multiple k-Ohms was observed. Auger analysis showed significant carbon and sulfur residuals on contact surfaces. Cleaning of released switches using diluted HF reduced contact resistance substantially, but consistent results were difficult to achieve. A set of Auger spectra from switches at various cleaning stages are shown in Figure 4. The carbon/sulfur contaminants were mostly traced back to the photo-resist we used as the release layer at the time and the resist stripping process. To eliminate this source of contamination, we developed plated Cu sacrificial layer and the corresponding release process.

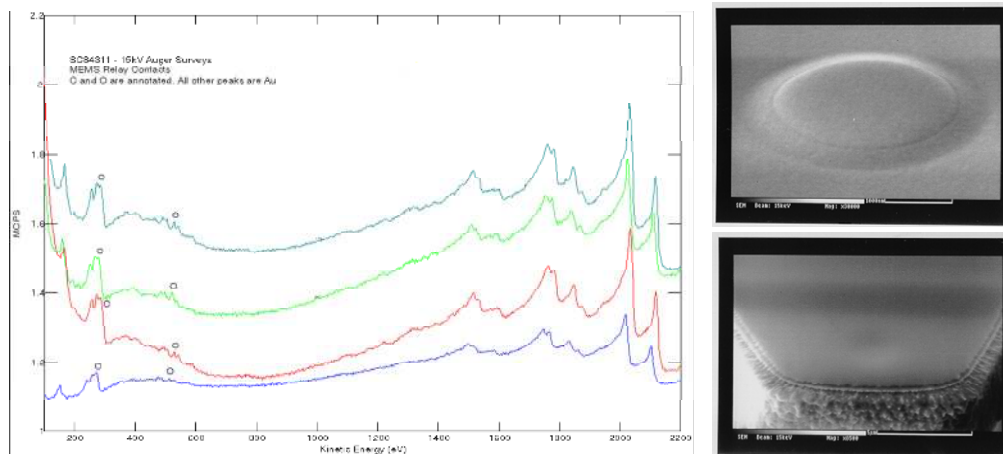

Figure 4. A set of Auger spectra showing various contamination levels at different stages of cleaning. The SEM micrographs on the right show the top and bottom of a contact.

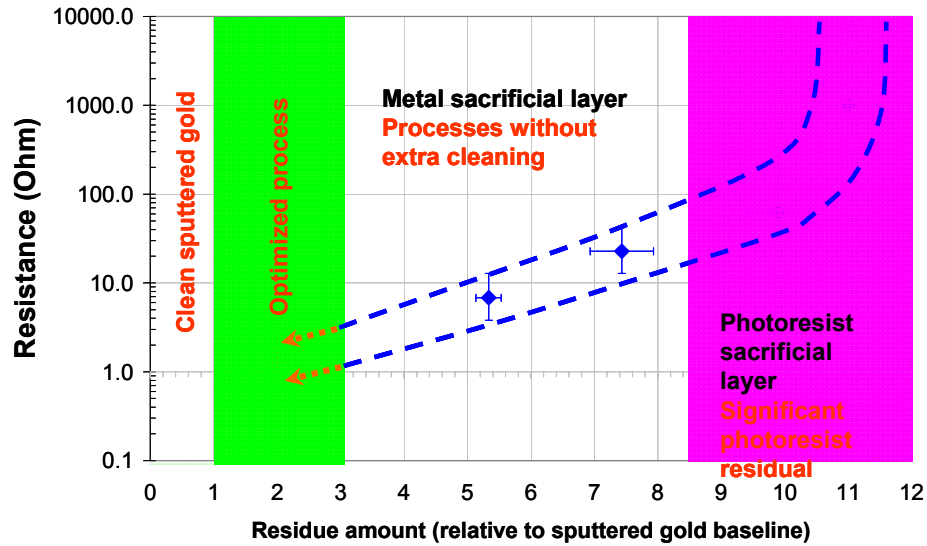

Figure 5. Switch contact resistance as a function of organic residual contamination level determined by Auger spectroscopy. Significant improvement was achieved by using metal sacrificial layer instead of photoresist sacrificial layer. Optimized cleaning process brings down the residual level close to that of freshly sputtered Au film.

With the main source of organic contamination removed and contact resistance significantly reduced, efforts were focused on further reduction of contact resistance by using dedicated cleaning techniques. Several extra-cleaning steps were introduced, after removing each patterning resist layer, particularly the mold resist. To test the effectiveness of such cleaning steps, not only contact resistance was measured, but also Auger data collected and compared to freshly sputtered films. The results are summarized in Figure 5 – low contact resistance was achieved when contamination levels were reduced to levels close to that of sputtered films. Figure 6 shows a detailed comparison of the contact resistance between a fresh sputtered Au film and a Au film that went through a complete switch process. It can be seen that the processed Au film had a slightly higher contact resistance due to slight residual contaminants on the Au surface. The resistance vs. contact force curves were obtained using the apparatus shown in Fig. 10 described in section 2.5.

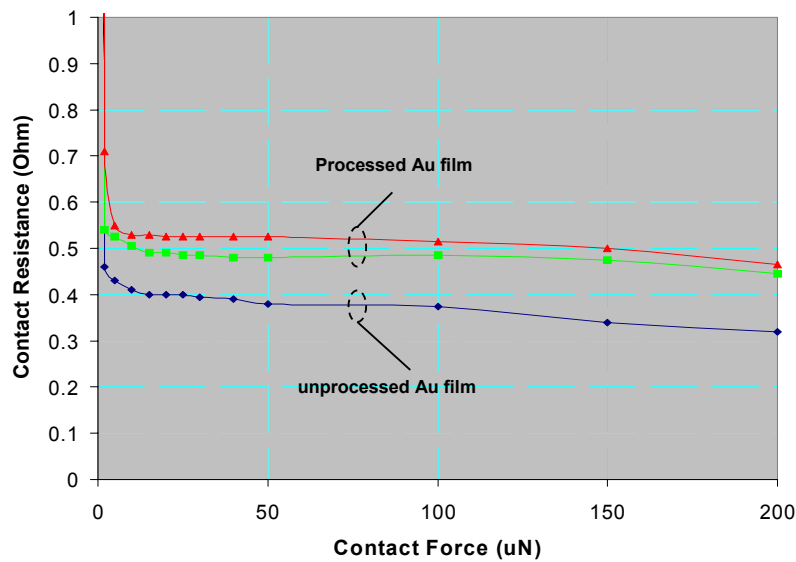

Figure 6. Contact resistance measured as a function of contact force for a fresh sputtered Au film and a Au film that went through typical switch processing steps.

2.3 Environmental Contamination

While the switch cleanliness was effectively addressed with the new process development described earlier, the contact contamination also arose from exposure to ambient. Tests were conducted to understand the effect of device exposure to the processing clean room and testing lab environments with various durations. Figure 7 shows the results of one such experiment by using Auger to monitor surface contamination accumulation after a wafer was exposed in clean room ambient after finishing processing, shipped in hermetic metal box filled with N₂ and waited for tests. It was found that the chemicals in the processing lab ambient could deposit on the switch surface rather rapidly. Special metal boxes with N₂ purge capability developed for shipping and storage were proven to be quite effective as the contamination accumulation rate was much slower. In the testing lab, although less chemicals were present in the ambient, contamination still built up on switch surface over time.

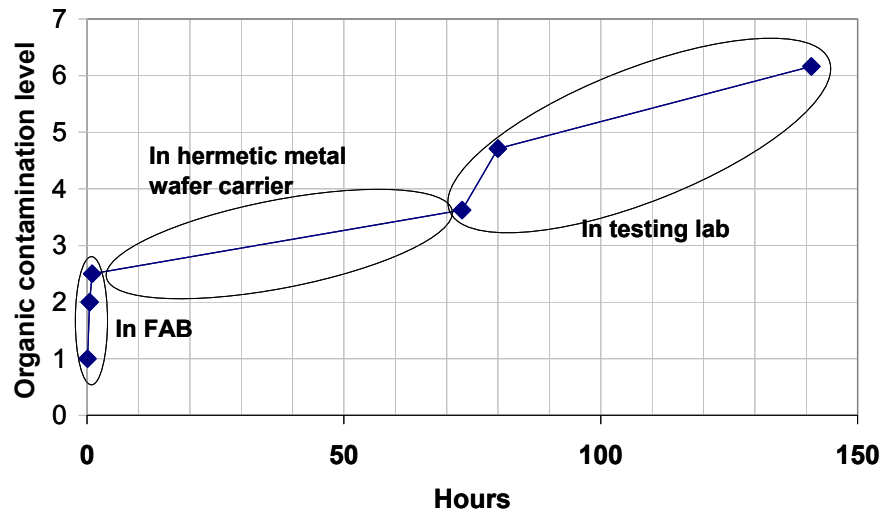



Figure 7. Organic contamination accumulated measured using Auger on Au surface as a function of exposure time. The contamination level is scaled by that of fresh Au surface.

From the tests we had, it was clear that while storing wafers in clean N₂ could slow down environmental contamination of the switches, gradual contamination accumulation still occurred. It was found that even in N₂ filled hermetic metal boxes, contact resistance still increased appreciably after two weeks. To reduce the degradation effect due to wafer storage, plasma cleaning techniques were also developed to clean the wafers just before wafer bonding packaging. It was found that direct exposure to plasma damaged switches and down stream plasma tools provided effective cleaning without causing damages. While oxygen plasma was effective in removing organic contamination, it also created dangling bonds at the surface. These dangling bonds attracted contamination in the air so that recontamination occurred very quickly. To overcome this problem, forming gas plasma was used immediately after oxygen plasma to terminate the dangling bonds. This process produced very clean and stable contacts, sometimes even cleaner than just-processed wafers.

2.4 Hermetic packaging

Given the critical importance of clean contacts, it is evident that the packaging technique used must provide clean and hermetic cavities to house the switches. Many packaging technologies were considered as summarized in Table 2. For the switch application, we only considered bonding methods that used hermetic sealing materials, such as metals and glass frit. Metallic bonding techniques are particularly suitable for switch packaging for several reasons. In addition to their ability to provide truly hermetic sealing, metallic bonding can accommodate certain amount of non-planarity by plastically yielding (thermal compression) or flow (solder bonding). For RF applications, metallic bonding could also provide low-loss electrical connection between the device and the cap. Several packaging methods that were developed for Intel's MEMS switch are shown in Fig. 8 [8, 9].

Table 2. Methods of bonding and sealing MEMS wafer-level packages.

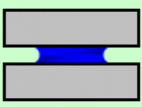
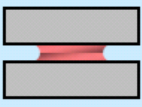
Techniques		Advantages	Drawbacks
“Surface” bonding		Hermetic	Flat surface required
	Anodic	strong bond	high-voltage
	Fusion (Direct)	strong bond	high temp
	Surface-activated	varies	varies
Metallic interlayer		Hermetic Non-flat surface ok	Specific metals required
	Eutectic	strong bond	flat surface req'd
	Thermocompression	non-flat surface ok	high force
	Solder	self-aligning	solder flow possible
Insulating interlayer			Varies
	Glass frit	hermetic common in MEMS	large area medium-hi temp
	Adhesive	versatile	non-hermetic

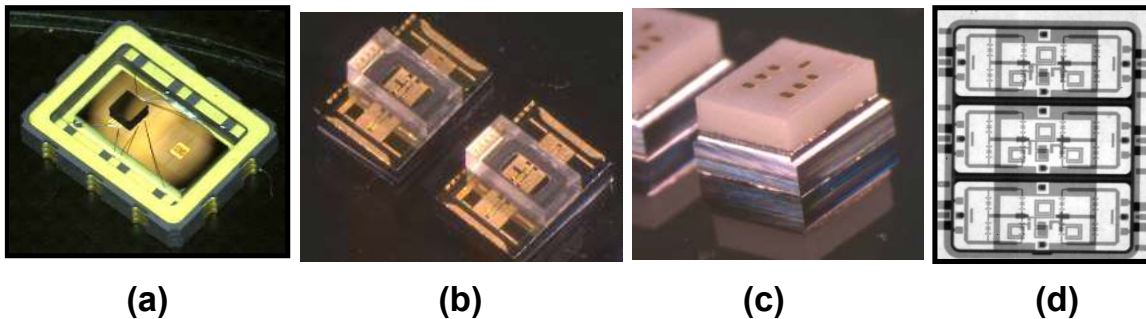

Figure 8. (a) Ceramic cavity package (b) Switches packaged by wafer-level bonding of a glass cap wafer using a glass frit seal (c) Switches packaged by wafer-level bonding of a ceramic cap wafer using a AuSn solder seal (d) X-ray of a switch module packaged by wafer-level bonding of a silicon cap using a gold thermocompression seal.

Switch performance was found to be significantly affected by the package type and method. One of the most dramatic improvements in contact lifetime occurred once the switch was packaged in a clean and hermetic cavity. A comparison between switching cycle lifetime measurement in air and in package is shown in Fig. 9. While the insertion loss of unpackaged switches tested in air typically increased after several million cycles, switches that were carefully packaged in an inert ambient reached several hundred million to 1 billion cycles with little or no contact resistance change [10]. Such results were obtained using solder bonding as well as gold thermocompression bonding.

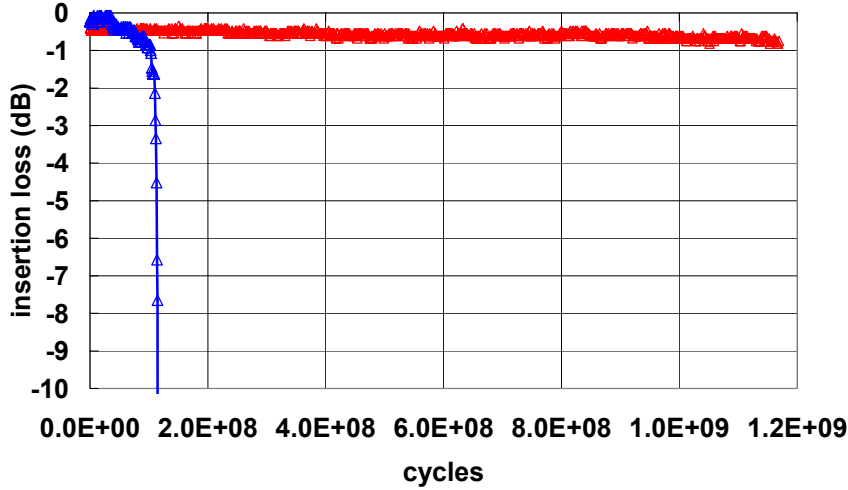

Figure 9. Insertion loss degradation as a result of switch cycling test. The blue points represent a switch that was tested in open environment with N₂ purge, and the red points show a switch that was hermetically packaged.

It was postulated that in an open environment, even with N₂ purge, there is an unlimited quantity of contaminants. Although the current passing through a switch contact is very small, the current density is actually very large given that the real contact area is of diameter ~ 0.1 μm. The large current density generates significant heat and electric field locally to polymerize any organic molecules in the region. Meanwhile, more and more molecules are getting deposited in the fashion similar to carbon deposition induced by e-beam in a SEM. In a small hermetically packaged cavity, the total available contaminants are very much limited, resulting much longer lifetime. Further improvements could potentially be achieved by integrating getters in the package.

2.5 Contact metal selection

In order to achieve low contact resistance and long contact lifetime, a clean contact surface is essential. However, it was observed that cleaner contacts tend to have more stiction problems during switching cycles. The stiction problem was particularly severe for soft metals, such as pure Au. In addition, it was reported [11] that the predominant failure mechanism of clean pure Au contacts was pitting and hardening damage of contact area due to repetitive impact. Further, when a switch carries relatively large current, local melting at the Au contact may occur especially in the case that contact pitting and hardening damage is formed. As a result, pure Au contact may not be suitable for RF switch applications requiring long cycling lifetime. The contact metal must be carefully engineered to meet the requirements.

The selection of contact metal depends on material hardness, resistivity, melting point, and process difficulty. Table 2 lists several potential metals that could provide some of the desirable trade-offs. These contact metals are also used in traditional relays for different applications. Note that the metal properties can vary significantly based on the deposition condition of material. It was observed that the resistivity of a sputtered metal film could be twice its bulk resistivity. More complex Au-based alloys and Pt-based alloys are not included in the table due to significantly more difficult processing and integration for the switch fabrication. If the two sides of a contact are made of the same material, the contact resistance can be expressed as

$$R_c = \frac{\rho}{\pi r} \propto A^{-1/2} \quad (1)$$

where ρ is the resistivity, r is the contact radius, and A the contact area. In the plastic regime, the contact area A is given by

$$A = \frac{F}{nH} \quad (2)$$

where F is the contact force, H is the material hardness, and n is a material dependent empirical factor, which is sensitive to surface contamination. When a very small contact force is applied, a more complex elastic-plastic contact model with multi contact asperities may be required [12]. The contact physics in such region is not well understood, especially when a mono-layer of impurity is present.

Table 2. List of potential switch contact metals

Metal	Symble	Resistivity, x10-6 ohm-cm	Estimated Hardness (Mpa)	Melting Point, oC	Chemical Reactivity	Process Complexity
Gold	Au	~2.2	~250	~1060	Lowest	Simple etch
Gold Nickel	AuNi5	~12	~1600	~1040	Very Low	Simple etch
Rhodium	Rh	~4.3	~2500	~1960	Low	Difficult etch
Ruthenium	Ru	~7.1	~2700	~2330	Low	Difficult etch
Iridium	Ir	~4.7	~2700	~2460	Low	Difficult etch
Tungsten	W	~5.48	>3000	~3420	Medium	Simple etch
Molybdenum	Mo	~5	~2000	~2620	Medium low	Simple etch

Pure Au provides the lowest contact resistance as seen from Eq. 1 and it is most inert to oxidation. However, Au contacts have damage and stiction problems as discussed earlier. While harder metals tend to have less stiction problems, they lead to higher contact resistance because the real contact area reduces. Meanwhile, most metals have certain sensitivity to oxidation. This is important because even in a hermetic package filled with pure N_2 , a trace amount of O_2 still exists and could cause slight oxidation at the contact after a long period of operation. At low contact force, a drastic increase of the switch contact resistance could occur due to such oxidation.

To investigate these contact metal candidates, it was not practical to integrate them into switches for testing. For fast information turn, a special apparatus shown in Fig. 10 was developed. To study a pair of contact metals, one was sputtered on a silicon substrate; the other was sputtered on a conductive tip made of tungsten. The tip, carried by a Pico-Indenter head was used to tap the metal on the substrate with controlled impact and contact forces, mimicking the switch action at the contact. A current source was used to pass a controlled current through the contact when the tip is touching the metal on the substrate. The Pico-Indenter setup is placed in a constant N_2 -flushed chamber (>95% N_2) to reduce the environmental contamination.

Figure 11 shows the contact resistance of pure Au, AuNi, and Rh as a function of contact force. Both Au and AuNi showed very stable contact resistance with contact force of $<30\mu N$. However, Rh required at least $50\mu N$ of contact force to reach a relatively stable resistance value. AuNi has a contact resistance of ~ 1.5 ohm with a contact stiction force of $\sim 5\mu N$, the minimum detectable level in this system. The hard Rh film showed a contact resistance of 3 ohm with undetectable contact stiction. It was also observed that the contact resistance of Rh film increased by almost 1 ohm after five days in the chamber while the contact resistance of Au and AuNi film did not change over such period. Since the N_2 -flushed chamber was not O_2 free, it is suspected that the Rh film experienced a slight oxidation over the time period, which resulted in change of contact resistance. Since rhodium oxide is still conductive, a stable contact resistance was still obtained with relatively large contact force ($>100\mu N$). Similar results were also observed for Ir and Ru contacts. These hard metals provide excellent performance for the switches with adequate contact force. However integration of these materials in the process flow is rather difficult. Further, they are not suitable for switches with low actuation voltage ($<20V$) and therefore low contact force ($<100\mu N$) due to unstable and high contact resistance.

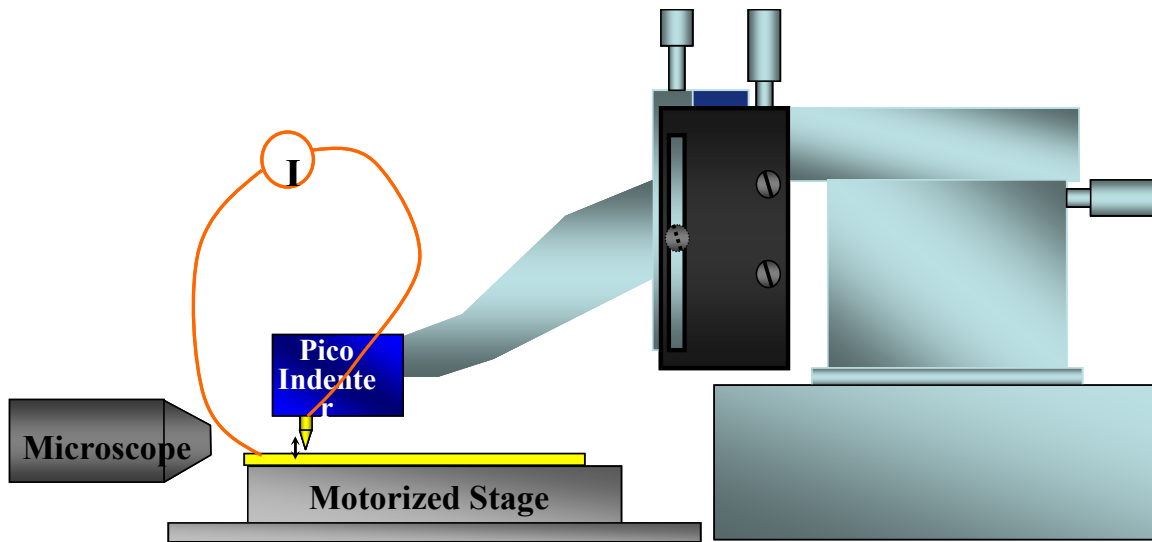

Figure 10. Schematic illustration of Pico-Indenter set up.

Tungsten and Molybdenum with even larger hardness values did not show stiction issue. With very high melting temperatures, they should be able to handle relatively large power. However, they were found to be more sensitive to oxidation, so relatively high initial contact forces ($>150\mu\text{N}$) were needed to achieve stable contact resistance. As a result, W and Mo are not suitable as switch contact materials. Overall, the test results showed that AuNi alloy provided an attractive trade-off between adequate conductivity, easy integration and manageable stiction.

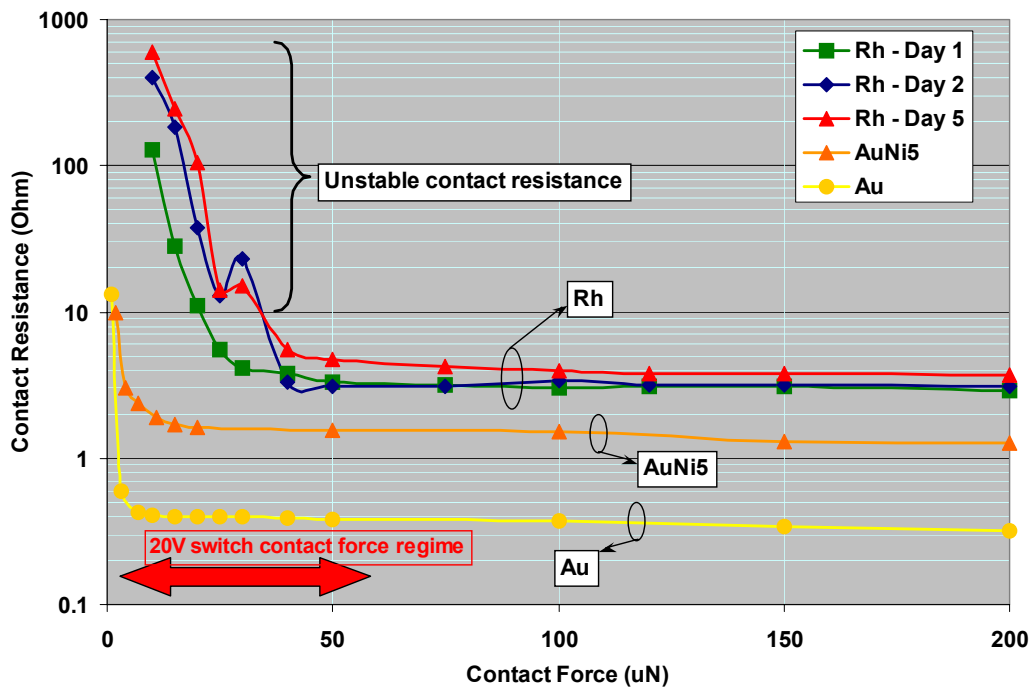

Figure 11. Contact resistance as a function of contact force for several contact metal candidates.

2.6 Mechanical design for contact reliability

As mentioned earlier, contact reliability is particularly difficult to achieve for MEMS switches because the available contact force is typically very small. With the exception of relatively large electromagnetically or thermally actuated switches targeting the discrete components market, switches designed for on-chip integration with other RF components are small in size and are typically electrostatically actuated. The actuation force from electrostatic actuation is usually very limited for any reasonable actuation voltages. Therefore the contact force and the restoring force are also very limited resulting in extreme sensitivity to contamination and stiction failures. The solution paths described so far focus on improving contact surface conditions, such as eliminating contamination and reducing stiction force by proper metal selection. However, it is clear that any increase of contact and restoring force through mechanical design would be highly effective as well.

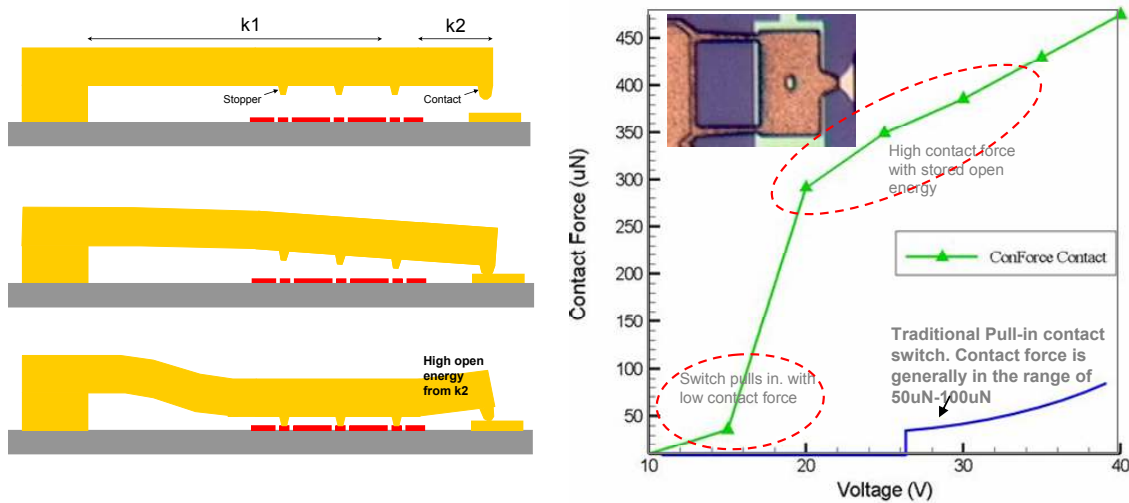

Figure 12. Collapsing cantilever switch capable of providing large contact force. Schematic illustration of actuation mechanism on the left. Simulated contact force curves plotted for both a collapsing switch and a regular cantilever switch plotted on the right.

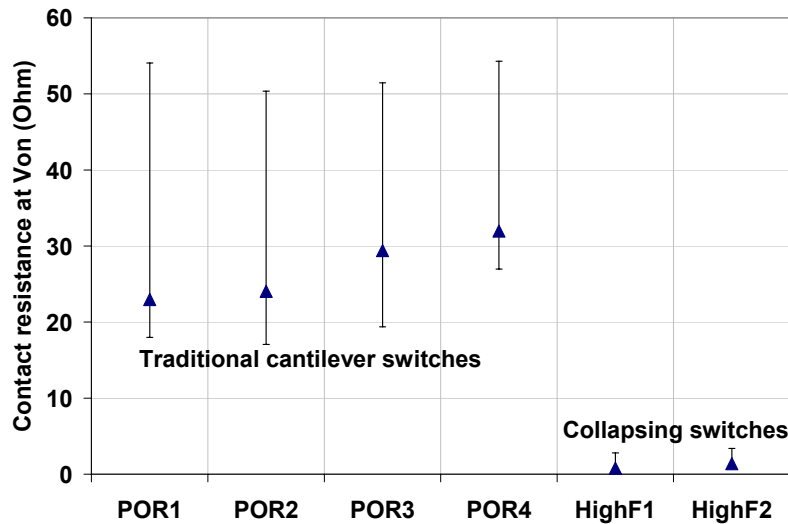

Figure 13. Contact resistance values from traditional cantilever switches and from collapsing switches. Both types of switches were exposed to lab ambient for extended period of time.

Figure 12 shows one such mechanical design with a high contact force. The switch beam consists of a compliant spring k_1 that allows low pull-in voltage, and a stiff contact beam k_2 . A relatively low actuation voltage pulls down the cantilever beam with a small initial contact force similar to that of a conventional cantilever switch. As the voltage increases, the top beam collapses on the stoppers designed to prevent the beam from shorting the bottom actuation electrode. With the cantilever collapsed, a high electrostatic force is transferred to the contact via the stiff spring k_2 , and a large opening elastic energy is stored in k_2 as well. It can be seen from Fig. 12 that contact force of $> 300\mu\text{N}$ can be achieved with this design compared to $< 100\mu\text{N}$ of conventional non-collapsing switch structure. When the actuation voltage is removed, the stored opening elastic energy in spring k_2 overcomes any stiction and breaks the switch contact. With this design, high contact and open forces was achieved, leading to improved reliability. Figure 13 shows that the collapsing switches were much less sensitive to contaminants on the contact surface.

3. CLOSING REMARKS

From the discussions in the previous section, it is clear that special efforts must be made in order to produce reliable switches. First, MEMS switches are much more sensitive to organic contamination than either IC or other MEMS devices we are aware of. As a result, from the start of wafer processing all the way to sealing the switch hermetically, every effort must be made to avoid organic contaminants. Techniques we have implemented include inorganic sacrificial material, dedicated cleaning steps after stripping photo-resist, particularly the plating mold resist, ultra clean and hermetic metal storage box, and additional plasma clean immediately before wafer bonding. Second, the requirements for the contact metal are very stringent – the contact must have excellent electrical conductivity for low loss, high melting point to handle power, appropriate hardness to avoid stiction and chemical inertness to avoid oxidation and other chemical reactions. Finally, hermetic packaging technology using low vapor pressure metal or solvent free glass-frit must be used to achieve low leakage and to avoid contaminating switches during bonding. All these special efforts inevitably raise the manufacturing cost of MEMS switches. Therefore a major challenge is to achieve reliability with technologies consistent with the cost structure of consumer wireless applications. Using the reconfigurable RF front-end illustrated in Fig. 1 as an example, while the opportunity for RF MEMS switches is indeed vast, the cost of each switch must be of order of a few cents to be economically viable. Individual discrete switches would have difficulties meeting such a cost target. In addition, multiple discrete switches would likely introduce form factor issues, particularly for mobile applications. There are, however, two approaches that could alleviate both cost and form factor issues. First, switches working together, in a switchable filter bank, for example, can be grouped as a module so that they can be packaged together compactly. This approach could reduce switch component count by an order of magnitude, saving both cost and space. Second, switches and other passive components needed for the reconfigurable RF front-end can be co-processed on a single piece of silicon. This approach works particularly well if many processing steps can be shared between switches and other passives. Which one of these two approaches to select will depend on the application requirements and the architecture/design of the reconfigurable RF front-end.

REFERENCES

1. R. Hiremane, L. Swanson, M. Chartier, Q. Ma, "Radio Renaissance," Portable Design October, 2005.
2. J. Weiser, "Switching contacts in relays," ICEC '98. 19th International Conference on Electric Contact Phenomena. VDE -Verlag, Berlin, Germany; 1998; 507 pp. p.15-21
3. T. Yano, "Across-the-board improvements give reed relays into into communications/control applications," JEE- (Japan-Electronic-Engineering). no.116; Aug. 1976; p.22-5
4. D. Trowbridge, "Switching with the mercury-wetted-contact relay," Electronics-and-Power.-Journal-of-the-Institution-of-Electrical-Engineers. vol.22, no.8; Aug. 1976; p.523-5
5. F.A. Pieters, "Quality-dry reed switches," Electronic-Components-&-Applications. vol.8, no.2; 1987; p.87-94.
6. H. P. Koidl, W. F. Rieder, and Q. R. Salzman, "Influence of Physical/Chemical Characteristics of Organic Vapors and Gas Mixtures on their Contact Compatibility," IEEE Transactions on Components and Packaging Technology, vol. 22, NO. 3, September 1999.

7. J. Tringe, W. Wilson, and J. Houston, "Conduction properties of microscopic gold contact surfaces," *Reliability, Testing, and Characterization of MEMS/MOEMS*, Proceedings of SPIE Vol. 4558 (2001).
8. J. Heck, L. Arana, B. Read, and T. Dory, "Ceramic via wafer-level packaging for MEMS," *Proceedings of InterPACK 2005*, San Francisco, CA, July 2005.
9. J. Heck and S. Greathouse, "Towards Wafer-Scale MEMS Packaging: A Review of Recent Advances," *Proceedings of the Surface Mount Technology Association International Conference*, Chicago, IL, Sept. 2003, pp. 631-6.
10. T-K Chou, H. Bar, J Heck, Q. Ma, J. Melki, Q. Tran, S. Tubul, B. Weinfeld, N. Ziharev, "Billion-Cycle ULV Electrostatic RF MEMS Switch," *Solid-State Sensors, Actuators, and Microsystems*, Hilton Head, SC, June 2006, pp. 78-81.
11. G. M. Rebeiz, *RF MEMS Theory, Design, and Technology*, Wiley Interscience, 2003.
12. S. Majumder, N.E. McGruer, G.G Adams, P.M. Zavracky, R.H. Morrison, J. Krim, "Study of contacts in an electrostatically actuated microswitch," *Sensors and Actuators A: Physical*, Volume 93, Number 1, 25 August 2001, pp. 19-26.