

Розроблено метод комплексної оцінки стану каналу багатоантенних систем радіозв'язку. Відмінна особливість запропонованого методу полягає в оцінці стану каналу багатоантенних систем радіозв'язку за декількома показниками, а саме: ймовірність бітової помилки каналу, частотна характеристика стану каналу та імпульсна характеристика стану каналу. Після отримання оцінки каналу по кожному показнику відбувається формування узагальненої оцінки стану каналу. Формування оцінки стану каналу по кожному з показників оцінки відбувається на окремому шарі нейронної мережі з використанням апарату нечітких множин, після чого на виході нейронної мережі формується узагальнена оцінка. Розробка запропонованого методу обумовлена необхідністю підвищення швидкості оцінювання стану каналу багатоантенних систем радіозв'язку з прийнятною обчислювальною складністю.

За результатами дослідження встановлено, що запропонований метод дозволяє підвищити швидкість оцінювання стану каналу багатоантенних систем в середньому до 30 % в залежності від стану каналу, при цьому відмічається погіршення точності оцінки стану каналу на рівні 5–7 % за рахунок зменшення інформативності оцінювання (це обумовлене використанням апарату нечітких множин) та здатний адаптуватися до сигнальної обстановки в каналі за рахунок навчання нейронної мережі. Навчання нейронної мережі відбувається на основі навчальної (тренувальної) послідовності та на 10–12 ітерації навчання повністю завершує адаптацію до стану каналу. Зазначений метод доцільно використовувати в радіостанціях з програмованою архітектурою для підвищення їх завадозахищеності за рахунок зменшення часу на прийняття рішення щодо стану каналу.

Ключові слова: засоби радіозв'язку, нейронні мережі, нечіткі множини, обчислювальна складність, частотна характеристика, імпульсна характеристика.

UDC 621.396

DOI: 10.15587/1729-4061.2018.144085

METHOD OF INTEGRAL ESTIMATION OF CHANNEL STATE IN THE MULTIAN TENNA RADIO COMMUNICATION SYSTEMS

S. Kalantaievska
Adjunct

Department of Scientific and organizational
Military institute of telecommunications and informatization
named after Heroes of Kruty
Moskovska str., 45/1, Kyiv, Ukraine, 01011

H. Pievtsov

Doctor of Technical Sciences, Professor,
Deputy Chief*

A. Kuvshynov

Doctor of Technical Sciences, Professor, Deputy Chief
Educational-Scientific Institute***

A. Shyshatskyi

PhD, Researcher****
E-mail: ierikon12@gmail.com

S. Yarosh

Doctor of Military Sciences, Professor, Head of
Department of tactics of anti-aircraft missile troops*

S. Gatsenko

Senior Lecturer**

H. Zubrytskyi

PhD, Associate Professor, Leading Researcher*

R. Zhyvotovskyi

PhD, Head of Department****

S. Petruk

Senior Researcher****

V. Zuiko

PhD, Associate Professor**

*Ivan Kozhedub Kharkiv National Air Force University
Sumska str., 77/79, Kharkiv, Ukraine, 61023

Department of Space Systems*

***Ivan Chernyakhovsky National Defense University of Ukraine
Povitroflorski ave., 28, Kyiv, Ukraine, 03049

****Research department for the development of
anti-aircraft missile systems and complexes*****

*****Central scientifically-research institute of arming and
military equipment of the Armed Forces of Ukraine
Povitroflorski ave., 28, Kyiv, Ukraine, 03168

1. Introduction

Multiple Input Multiple Output (MIMO) technology has found practical application in many modern telecom-

munication systems. It is used in wireless local networks (IEEE 802.11n Standard), WIMAX and LTE wireless mobile networks, etc. [1–5]. The essence of MIMO technology is similar to the method of diversity reception when several

uncorrelated copies of the signal are created at the receiving side by means of diversity of antennas in space and polarization, diversity of signals in frequency or time.

Spatial multiplexing is realized in MIMO radio communication systems: the transmitted data stream is split into two or more sub-streams each of which is transmitted and received using diverse antennas [1–10].

Anti-interference ability of multiantenna radio communication systems is influenced by jamming or signal fading during multipath propagation of radio waves. To provide stable radio communication under conditions of active radio-electronic jamming and selective fading, radio communication system should have information about signal and interference conditions in the channel.

Development of radioelectronic warfare means, imperfection of known methods (procedures) for estimation of channel state in MIMO systems necessitate search for new scientific approaches to improvement of anti-interference ability of MIMO systems to a proper level.

In order to reduce time of adaptation of radio communication facilities in conditions of influence of radioelectronic warfare means, it is necessary to reduce time of channel state estimation while maintaining due reliability. To this end, it is necessary to develop new methods for channel state estimation.

All this confirms relevance of the chosen study direction.

2. Literature review and problem statement

When designing adaptive radio communication systems, the task of optimizing one of performance indicators at remaining restrictions to others must be solved depending on system destination. To this end, two basic methods of monitoring the radio channel state [5, 6] are used.

The first of them involves estimation of the channel state on the basis of monitoring primary signal and interference parameters: amplitude, smoothed amplitude value (level), duration, signal/interference amplitude or level ratios, etc. The second method is based on estimation by analyzing secondary parameters: frequency of errors occurring in receiving of message symbols, number of requests in systems with critical feedback, various code signs, etc.

The first way to monitor the state of radio channels is definitely more effective for modern radio communication systems [5, 6]. This is due to the fact that this estimation method is most informative and allows one to determine type of interference and its parameters, the law of setting and the frequency ranges free from interferences.

The multipath channel features its non-stationary nature caused by presence of constant variation of signal propagation conditions in the channel which results in distortion of the transmitted signal. Besides the distortions caused by the special nature of radio wave propagation, jamming and accidental interferences may influence the transmitted signal.

A method for estimation of the MIMO system channel state was developed in [3]. It is based on obtaining of a pilot signal at the start of communication session and conducting further estimation based on correlation between the message blocks. Disadvantage of the proposed method is estimation of state of the MIMO system channel just for one indicator, namely, the bit error probability by means of blind estimation. The method is not intended for estimation as regards several indicators of the channel state simultaneously.

A method for estimation of state of the MIMO system channel was developed in [4]. It is based on estimation of a single channel frequency band based on a discrete Fourier transform. The obtained estimate is subsequently extrapolated to another channel part. The proposed method cannot be used in conditions of active radioelectronic jamming because it does not take into account frequency response in the frequency domain to which the obtained estimation is extrapolated and is not able to assess other interference parameters obtainable due to the pulse response and the bit error probability.

A procedure for estimation of the MIMO system state is proposed in [5] with taking into account configuration of the MIMO system and speed of the subscriber's terminal movement, however, this method does not take into account the effect of interferences generated by radioelectronic warfare means.

A method for estimation of the MIMO system channel is proposed in [6]. It is based on the use of training signals with code division distributed over the packet length. This method assesses the channel state only on the basis of the bit error probability which does not allow one to obtain information about the cause of appearance of these errors.

Study [7] is devoted to development of a blind algorithm for estimation of state of the multiantenna system channel. The algorithm is based on properties of the mutual signal information for estimation of the channel matrix but this method also leads to a gradual accumulation of estimation errors and can be used only in non-critical systems.

A method for estimation of the MIMO system channel based on Kalman filtering in a frequency domain was developed in [8] but it does not ensure obtaining of information about signal and interference levels in the MIMO system channel.

The effect of interferences on performance of MIMO systems was considered in [10] with estimation on the basis of just the bit error probability which does not make it possible to work out effective measures of adaptation to the situation in the channel.

Therefore, the main drawbacks of these methods include low rate of estimation of the channel state, impossibility of adaptation to the signal situation in the channel and obtaining of a generalized (integrated) estimate of the channel state.

These drawbacks can be eliminated by estimation of state of the MIMO system channel through the use of neural networks. Analysis of the use of neural networks to assess state of the MIMO system channel will be made.

A method for increasing capacity and estimation of state of MIMO system channels using neural networks was developed in [11]. However, the channel state was assessed by the method of brute force (a complete overview of possible options is considered in [11]) which results in a large calculational burden. Complexity of obtaining results by the method of exhaustive search depends on the number of all possible solutions to the problem. If the solution space is very large, then the complete overview of all possible values may last for years.

Estimation of the MIMO system channel using a neural network was made in [12]. The results obtained have shown a significant advantage over the stochastic estimation. However, this approach ensures the channel state estimation only for one indicator.

A method of MIMO-OFDM system channel state estimation with the use of a neural network was developed in [13]. The results obtained have shown a significant advantage of neural networks in comparison with known

approaches. The authors assessed the channel for probability of a bit error, square root error and by the least square method. In the proposed method, the channel state is assessed for a single indicator.

A method for estimation of the MIMO system channel state and the method of equalizing its parameters using the neural network were developed in [14]. The channel was assessed by the proposed method for the probability of a bit error.

A method for estimation of state of the MIMO system channel was developed in [15]. The essence of the proposed method is to assess state for the probability of a bit error and the signal/interference ratio. These indicators do not give a complete description of the communication channel state.

A method for estimation of the channel matrix of the MIMO system based on the criterion of minimal root mean square error was developed in [16]. The essence of the proposed method is to assess the channel state by minimizing the root mean square error by using the neural network. However, the proposed method does not make it possible to assess other indicators or several indicators simultaneously.

A method for estimation of the MIMO system channel has been developed in [17] by the criterion of minimum root mean square error. The idea of this method is to assess the channel state for the minimum root mean square error and predict the channel state using a neural network. The method is based on a combination of iterative recovery of signal parameters and the technology of deep training of neural networks. However, estimation for only one individual indicator limits its application.

A method for estimation of the MIMO system channel with the help of a neural network was developed in [18]. This method is intended only for estimation of the bit error probability and is unadaptable to multi-parameter estimation of the channel state.

A procedure for controlling the MIMO system parameters and a method for estimation of the MIMO system channels through the use of neural networks were developed in [19]. The procedure is intended for estimation and correction of the MIMO system parameters based on estimation of the bit error probability. Other system parameters are not assessed in this case.

A method for estimation of state of the MIMO system channels using various types of neural networks was developed in [20]. Frequency response of the channel is assessed by this method.

A method for compensating phase noise using neural networks and its application for MIMO systems were developed in [21]. Phase noise of the channel and the bit error probability are assessed by this method.

A method of hierarchical estimation of state of a MIMO system channels using neural networks was developed in [22]. Sequential estimation of the channel state is performed in this method by means of complete enumeration of the channel state values by the criterion of minimizing the root mean square error. Further, the neural network is trained and a partial enumeration is made until the channel state is completely assessed. However, several indicators are not assessed there.

A method for predicting characteristics of the MIMO system channel state using neural networks was developed in [23]. In order to train the neural network, 11 characteristics of the channel are assessed, such as average delay of the signal passage time, characteristic of the propagation medium, azimuth of the signal output angle, azimuth of the signal arrival angle, characteristic of the signal propagation

medium in the angle of propagation, mean angle of signal propagation, the angle of further propagation of the signal, average angle of signal arrival, signal characteristic in the angle of further propagation, etc. Sequential rather than parallel estimation of above characteristics is done by this method which increases time of the channel state estimation. All these characteristics describe energy of signal losses during propagation but do not permit estimation of frequency response and the bit error probability in the channel.

A method of adaptive estimation of the channel state for Massive MIMO systems is proposed in [24]. Its essence consists in a joint adaptive estimation of the channel state by means of estimation of the bit error probability and the minimum root mean square error in the pilot carrier OFDM. This method does not make it possible to assess state of the channel for its pulse and frequency response.

A method for estimation of state of the communication system channel using the OFDM technology was developed in [25]. Its essence is to assess pulse response of the channel during transmission of an information symbol based on the Wavelet transform. Pulse response is not assessed for the remainder of time. Disadvantages of this method: it neither provides estimation of the channel pulse response in real time nor permits estimation of frequency response and the bit error probability.

A method for estimation of state of communication channels in systems using the MIMO-OFDM technology is proposed in [26]. In this study, estimation of a bit error probability in the channel state of the MIMO-OFDM systems is done using a compression algorithm, the descending line in the pilot carrier OFDM. Again, this method is not intended for estimation of several indicators of the channel state.

Analysis of known approaches to estimation of channel state in the communication systems using MIMO-OFDM technology is presented in [27]. Methods for estimation of the communication channel state based on estimation of the bit error probability are considered in this study. The estimation methods presented in this study are not capable to work with several indicators simultaneously.

Consequently, the analysis of use of neural networks in estimation of state of the MIMO system channels has shown that the above papers do not contain the following:

- parallel channel state estimation for several indicators;
- obtaining of a generalized estimate of the channel state;
- continuous estimation of several characteristics in real time;
- simultaneous estimation of both ascending and descending lines;
- combined pulse and frequency response of the channel state and the bit error probability are not used in estimation [11–27].

To this purpose, it is considered appropriate to assess state of channels of multiantenna radio communication systems for several indicators using apparatus of fuzzy logic and neural networks which will make it possible to establish a compromise between accuracy and simplicity of estimation.

3. The aim and objectives of the study

The study objective is to develop a method for integrated estimation of state of channels of multiantenna radio communication systems which will improve estimation accuracy at a moderate computational complexity.

To realize this objective, it is necessary to solve a number of interrelated tasks:

- to formalize the MIMO system operation;
- to analyze existing scientific and methodical apparatus for estimation state of communication channels;
- to identify shortcomings inherent in the process of estimation of state of communication channels and suggest ways to elimination of the identified shortcomings;
- to develop a method for integrated estimation of state of multiantenna radio communication system channels;
- to assess effectiveness of the proposed method;
- to develop practical recommendations for implementation of the proposed method in the radio communication facilities based on MIMO technology.

4. Formalization of the system operation and substantiation of choice of the study methods

Estimation of efficiency and modeling functioning of the proposed method for estimation of state of the MIMO system channel was conducted in MathCad 14 environment.

Adequacy and reliability of the developed method for estimation of state of the MIMO system channel were verified by means of comparison with the results presented by the *Iterative Solutions* group [38]. The designs presented on this e-resource make it possible to simulate characteristics of anti-interference ability of almost all known mobile data transmission systems.

4.1. Formalization of the MIMO system operation

In the general case, structure of the MIMO system includes M_t transmitters (transmitting antennas) and M_r receivers (receiving antennas), Fig. 1. The transmitted signals enter M_r receiving paths [1–10].

Let us consider the MIMO $M_t \times M_r$ system shown in Fig. 1. High-speed data stream is divided into M_t independent sequences with speed $1/M_t$ which are then transmitted simultaneously from several antennas, respectively, using only $1/M_t$ of the primary frequency band.

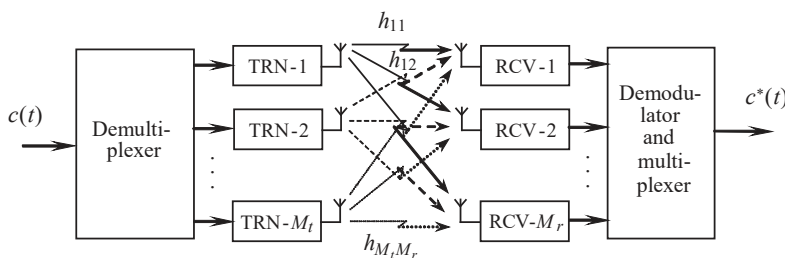

Fig. 1. Block diagram of the MIMO system

The data stream converter at the transmitter end of the communication line converts sequential stream into parallel streams. Inverse conversion takes place at the receiving end.

4.2. Analysis of the existing scientific and methodological apparatus for estimation of state of communication channels

Classical works [1–10] are devoted to development of methods for estimation of the communication channel state. In most of the above studies, it is assumed that any communication channel can be formally described as a rather simple

mathematical model. In the general case, such models use various differential equations.

A model can be described by a system of integral-differential equations or mixed systems. Mixed systems include differential, algebraic or transcendental equations that interlink individual parameters describing state of the communication channel.

Methods of parametric identification are most widely used in practical tasks of channel estimation. For their application, it is necessary to have a priori information in a form of a channel model equation in which only some parameters may be unknown.

Depending on the estimation criterion or the algorithm used to compute unknown parameters, these methods are called differently [28–31]:

- maximum likelihood method;
- method of Bayesian estimates;
- Kalman filter method;
- least squares method;
- method of averaged discrepancy;
- method of stochastic approximation.

4.3. Defining shortcomings inherent in the process of estimation state of communication channels and proposals for their elimination

The main shortcomings of above methods [28–31] are as follows:

- high computational complexity;
- as a rule, the «input-output» object model has no explicit interpretation (or has a cumbersome record form);
- there is no direct possibility of working with the variable «input-outputs» having a qualitative nature;
- there is no direct possibility of using information about the channel structure in a form of verbal statements of IF-THEN type obtained based on decision maker’s experience.

Taking into account the aforementioned, authors propose to use fuzzy logic of communication channel description in conjunction with an apparatus of neural networks for adaptive estimation of the channel state.

5. Development of the method for integrated estimation of channel state in multiantenna radio communication systems

Under the integrated (generalized) estimation, we mean obtaining (by a separate layer of the neural network) of the channel state estimation for frequency response, pulse response and the bit error probability. After processing in the layers of the neural network, a generalized estimate of the channel state is formed at the network output.

The generalized estimate allows one to determine mechanisms of correction of channel characteristics in terms of power level and frequency range and quantitatively assess influence of interferences with the help of knowledge on the bit error probability.

The method of integrated estimation of channel state in the multiantenna radio communication systems (its algorithm is shown in Fig. 3) includes the following stages.

1. Entering initial data (action 1 in Fig. 3).

Parameters of the transmitting facility and the communication channel are entered: $Y = \{y_i\}$, $i = \overline{1, m}$, where

$y_1...y_m$ are the position data of the signal ensemble, M ; maximum power of the useful signal, $P_{c \max}$; signal/interference ratio thresholds, Q_{th}^2 data transmission rate, v_i ; parameters of the correcting code (code rate, R ; number of errors corrected by the code, s).

Limitations include modulation type (quadrature amplitude modulation (QAM)), phase modulation (FM); dimensionality of the signal ensemble $4 \leq M \leq 256$; type of the correcting code (convolutional codes with rate $R=0.5-0.9$).

2. Estimation of the channel state (action 2 in Fig. 3).

Let us explain the procedure for estimation of the channel state. It consists in obtaining of integrated estimate of state of channels in multiantenna radio communication systems. Parallel calculations of pulse response of the channel state, x_1 , frequency response of the channel state, x_2 , and the bit error probability, x_3 , are performed in this procedure.

Thus, obtaining of integrated estimation of the state of the communication channel can be represented [31–39] in the form:

$$y = f(x_1, x_2, \dots, x_n).$$

Artificial neural networks (ANN) are widely used for adaptive signal processing, simulation, analysis and estimation of operational efficiency of communication networks. They are the adaptive systems simulating work of the nervous system of living organisms.

Adaptive filters using ANNs are capable of successful functioning in conditions of a priori uncertainty concerning the environment properties [40].

The principle of using an artificial neural network for estimation of state parameters of the MIMO system channel is shown in Fig. 2.

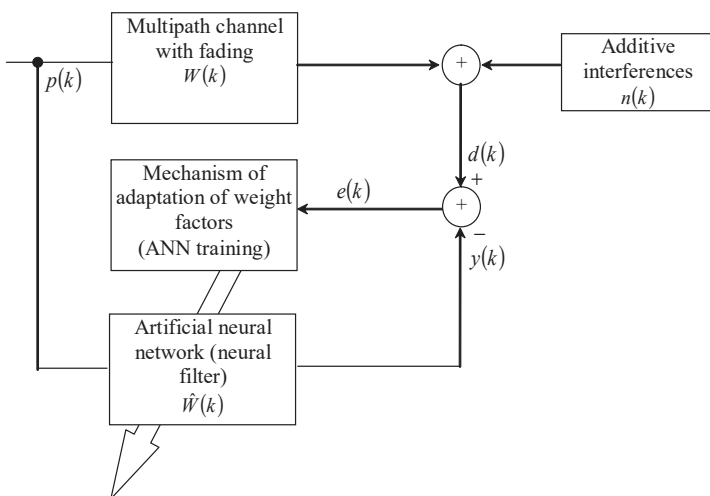

Fig. 2. Principle of adaptive estimation with the use of the ANN

In this method, each layer of the neural network performs estimation of a separately taken characteristic of state of the MIMO system channel with further formation of a generalized estimation of state of the MIMO system channel at the output of the neural network.

3. Estimation of frequency response of the channel (action 3 in Fig. 3).

Let the signal received at the analyzed frequency, $A_c(t)$, and its additive concentrated interference, $B_n(t)$, are narrowband quasi-stationary normal random processes with

a symmetric spectrum. Under the assumptions made, these processes can be represented through quadrature components [28]:

$$A_c(t) = Y_c(t) \cos \omega_c t + Y_s(t) \sin \omega_c t \tag{1}$$

and

$$B_n(t) = X_c(t) \cos \omega_n t + X_s(t) \sin \omega_n t, \tag{2}$$

where $Y_c(t)$, $X_c(t)$ and $Y_s(t)$, $X_s(t)$ are in-phase and orthogonal quadrature components of the signal and interference, respectively; ω_c and ω_n are medium frequencies of signal and interference spectra, respectively.

Further, it will be assumed that $\omega_c \approx \omega_n = \omega_0$ and that ω_0 is specified.

In the case of Relay fading which are characteristic for channels with multipath propagation of radio waves, quadrature components of the signal, $Y_c(t)$, $Y_s(t)$, and interference, $X_c(t)$, $X_s(t)$, are pairwise independent normal Markovian random processes with zero mean and dispersions $\sigma_{Y_c}^2 = \sigma_{Y_s}^2 = \sigma_c^2$, $\sigma_{X_c}^2 = \sigma_{X_s}^2 = \sigma_n^2$ [28].

Correlation functions of quadrature can be presented in this case as:

$$R_{Y_c}(\tau) = R_{Y_s}(\tau) = R_{Y_{quad}}(\tau) = \sigma_c^2 e^{-\alpha_c \tau} \tag{3}$$

and

$$R_{X_c}(\tau) = R_{X_s}(\tau) = R_{X_{quad}}(\tau) = \sigma_n^2 e^{-\alpha_n \tau}, \tag{4}$$

where $\alpha_c = 1/\tau_c$, $\alpha_n = 1/\tau_n$ are the parameters of correlation functions characterizing the speed of variation of signal and interference in quadrature reception channels, respectively.

To obtain estimates of signal and interference voltages ($\hat{y}(t) = 20 \lg \hat{A}_c(t)$ and $\hat{x}(t) = 20 \lg \hat{B}_c(t)$) smoothed during the estimation interval, the dependences can be used through corresponding estimates of the quadrature components smoothed during the same time interval:

$$\hat{y}(t) = 20 \lg \sqrt{\hat{Y}_c^2(t) + \hat{Y}_s^2(t)}, \tag{5}$$

$$\hat{x}(t) = 20 \lg \sqrt{\hat{X}_c^2(t) + \hat{X}_s^2(t)}. \tag{6}$$

Estimate of the ratio of smoothed voltages (levels) of the signal and the interference is determined from the expression:

$$s(t) = y(t) - x(t). \tag{7}$$

The model determining variation of the smoothed components of signal, $\hat{Y}_{quad}(t)$ and interference, $\hat{X}_{quad}(t)$ in each quadrature measurement channel is set in a discrete time in a two-dimensional space of states by a vector difference stochastic equation of the form:

$$\tilde{\mathbf{X}}(k+1) = \Phi(k+1)\tilde{\mathbf{X}}(k) + \Gamma(k+1)\tilde{\mathbf{U}}(k), \tag{8}$$

where

$$\tilde{\mathbf{X}}(k+1) = \left\| \hat{Y}_{quad}(k+1), \hat{X}_{quad}(k+1) \right\|^T$$

is the vector of state of signal and jamming components;

$$\Phi(k+1) = \text{diag} \left\| e^{-\alpha_y \Delta t}, e^{-\alpha_x \Delta t} \right\|;$$

$$\Gamma(k+1) = \text{diag} \left\| \sqrt{\frac{2}{\alpha_y}} (1 - e^{-\alpha_y \Delta t}); (1 - e^{-\alpha_x \Delta t}) \right\|;$$

$\tilde{\mathbf{U}}(k) = \left\| \tilde{U}_1(k), \tilde{U}_2(k) \right\|^T$ is the vector of white Gaussian noise with a zero mathematical expectation and a covariance matrix:

$$Q(k) = \text{diag} \left\| \frac{\alpha_y \sigma_y^2 (1 + e^{-\alpha_y \Delta t})}{2(1 - e^{-\alpha_y \Delta t})}; \frac{\alpha_x \sigma_x^2 (1 + e^{-\alpha_x \Delta t})}{2(1 - e^{-\alpha_x \Delta t})} \right\|;$$

σ_y^2 and σ_x^2 are dispersions; α_y and α_x are parameters of correlation functions of smoothed quadrature components of signal and interference, respectively.

and (9) leads to the following recurrent computational algorithm [29]:

$$\begin{aligned} \tilde{\mathbf{X}}(k+1) = & \left\| e^{-\alpha_y \Delta t} \dot{\tilde{Y}}_{quad}(k), e^{-\alpha_x \Delta t} \dot{\tilde{X}}_{quad}(k) \right\|^T + \mathbf{K}(k+1) \times \\ & \times \left\{ \tilde{Z}_{quad}(k+1) - \left[e^{-\alpha_y \Delta t} \dot{\tilde{Y}}_{quad}(k) + e^{-\alpha_x \Delta t} \dot{\tilde{X}}_{quad}(k) \right] \right\}. \end{aligned} \quad (10)$$

The matrix weight factor in expression (10) is determined as:

$$\mathbf{K}(k+1) = \left\| \frac{\rho_{11}(\Delta t) + \rho_{12}(\Delta t)}{\rho_{11}(\Delta t) + 2\rho_{12}(\Delta t) + \rho_{22}(\Delta t) + \sigma_n^2}; \frac{\rho_{12}(\Delta t) + \rho_{21}(\Delta t)}{\rho_{11}(\Delta t) + 2\rho_{12}(\Delta t) + \rho_{22}(\Delta t) + \sigma_n^2} \right\|, \quad (11)$$

where

$$\begin{aligned} \rho_{11}(\Delta t) &= P_{11}(k) e^{-2\alpha_y \Delta t} + \sigma_y^2 (1 - e^{-2\alpha_y \Delta t}), \\ \rho_{12}(\Delta t) &= P_{12}(k) e^{-(\alpha_y + \alpha_x) \Delta t}, \\ \rho_{22}(\Delta t) &= P_{22}(k) e^{-2\alpha_x \Delta t} + \sigma_x^2 (1 - e^{-2\alpha_x \Delta t}). \end{aligned} \quad (12)$$

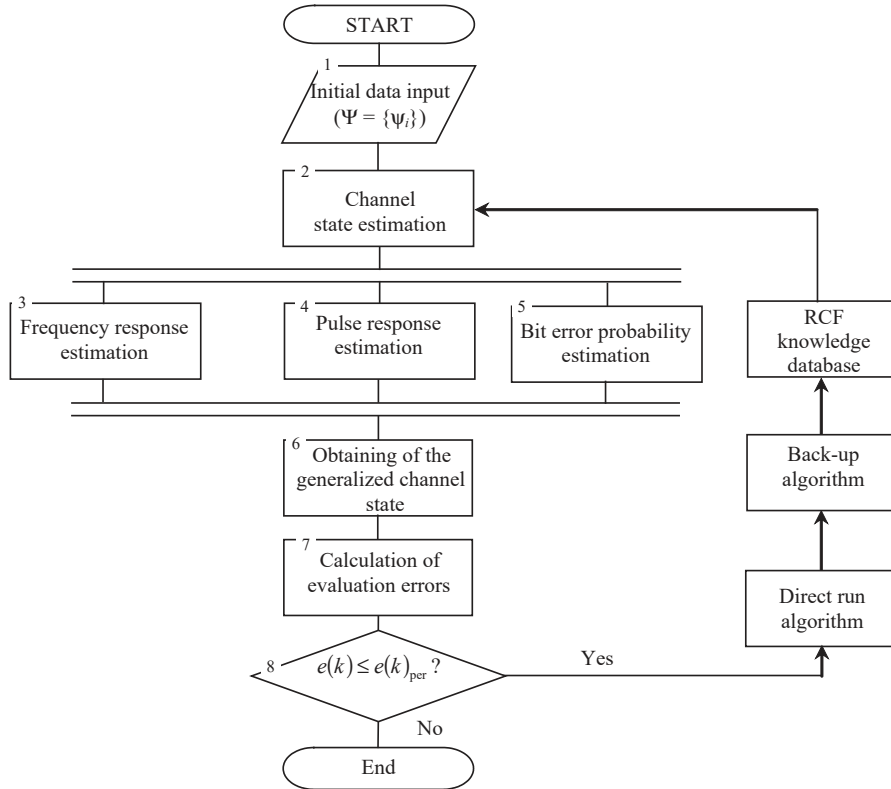

Fig. 3. Algorithm of implementation of the method of integrated estimation of state of multiantenna radio communication facilities (RCF)

Signal and interference in each quadrature measurement channel are observed in an additive mixture with the measurement noise:

$$\tilde{Z}_{quad}(k+1) = A(k+1)\tilde{X}(k+1) + \tilde{N}_{quad}(k+1), \quad (9)$$

where $\mathbf{A}(k+1) = \left\| 1, 1 \right\|$, and $\tilde{N}_{quad}(k+1)$ is the Gaussian white sequence with a zero mathematical expectation and a covariance function:

$$R_n(k, l) = \sigma_n^2 \delta_{k, l}.$$

Solution of the problem of optimal filtering for the model of state and observation described by equations (8)

Let binary signals $A_c^{(l)}(t)$ ($l=1, 2$) have the same energy and, like the additive interference, $B_n(t)$, are narrow-band quasi-stationary Markovian random processes with a symmetric spectrum. In particular, frequency-manipulated signals $A_c^{(l)}(t)$ ($l=1, 2$) can be represented through quadrature components.

When monitoring quality of radio channels directly in the process of data transmission, uncertainty about presence or absence of signals in the reception channels can be encountered. One of the most constructive approaches to solving this problem in such situation is synthesis of computational control algorithms based on a joint application of procedures of signal detection and estimation of parameters of both signals and concentrated interferences.

Let binary signals $A_c^{(l)}(t)$ ($l=1, 2$) have the same energy and, like the additive interference, $B_n(t)$, are narrow-band quasi-stationary Markovian random processes with a symmetric spectrum. In particular, frequency-manipulated signals $A_c^{(l)}(t)$ ($l=1, 2$) can be represented through quadrature components.

Let binary signals $A_c^{(l)}(t)$ ($l=1, 2$) have the same energy and, like the additive interference, $B_n(t)$, are narrow-band quasi-stationary Markovian random processes with a symmetric spectrum. In particular, frequency-manipulated signals $A_c^{(l)}(t)$ ($l=1, 2$) can be represented through quadrature components.

Let binary signals $A_c^{(l)}(t)$ ($l=1, 2$) have the same energy and, like the additive interference, $B_n(t)$, are narrow-band quasi-stationary Markovian random processes with a symmetric spectrum. In particular, frequency-manipulated signals $A_c^{(l)}(t)$ ($l=1, 2$) can be represented through quadrature components.

Let binary signals $A_c^{(l)}(t)$ ($l=1, 2$) have the same energy and, like the additive interference, $B_n(t)$, are narrow-band quasi-stationary Markovian random processes with a symmetric spectrum. In particular, frequency-manipulated signals $A_c^{(l)}(t)$ ($l=1, 2$) can be represented through quadrature components.

$$A_c^{(l)}(t) = Y_c(t) \cos \omega_0 t + Y_s(t) \sin \omega_0 t. \quad (13)$$

With no risk of reducing generality, consider the case of symmetric influence of a concentrated interference on the signals:

$$B_c(t) = X_c(t) \cos \omega_0 t + X_s(t) \sin \omega_0 t. \quad (14)$$

For the Rician and Rayleigh radio communication channels, dynamics of change of the quadrature components of signal and interference in discrete moments of time t_k ($k=0, 1, 2, \dots$) can be represented (by analogy with the expression (8)), by systems of stochastic vector difference equations:

$$\bar{\mathbf{X}}_{c(s)}(k+1) = \mathbf{\Phi}(k+1)\bar{\mathbf{X}}_{c(s)}(k) + \mathbf{\Gamma}(k+1)\bar{\mathbf{U}}(k), \quad (15)$$

where

$$\bar{\mathbf{X}}_A(k+1) = \|\bar{Y}_A(k+1), \bar{X}_A(k+1)\|^T;$$

$$\bar{\mathbf{X}}_s(k+1) = \|\bar{Y}_s(k+1), \bar{X}_s(k+1)\|^T;$$

$$\bar{\mathbf{U}}(k) = \|\bar{U}_1(k), \bar{U}_2(k)\|^T$$

are matrices $\mathbf{\Phi}(k+1), \mathbf{\Gamma}(k+1)$ i $\mathbf{Q}(k)$, however, parameters α_c, α_s and σ_c^2, σ_s^2 are used in them instead of parameters α_y, α_x and σ_y^2, σ_x^2 .

Note that the time sampling interval:

$$\Delta t = t_{k+1} - t_k \quad (k = 0, 1, 2, \dots),$$

is chosen in this case proceeding from the condition that $\Delta t \ll \min(\tau_c, \tau_n)$. According to statistical data, values of intervals of correlation of amplitudes of the fading signals (interferences) in radio communication channels measure tenths of second to one second [31].

Write the scalar equations of observation of signals and interferences on the noise background as follows:

$$\begin{aligned} \bar{z}(k+1) = & \chi \left[\mathbf{A}\bar{\mathbf{X}}_c(k+1)\cos\omega_{01}k\Delta t + \right. \\ & \left. + \mathbf{A}\bar{\mathbf{X}}_s(k+1)\sin\omega_{01}k\Delta t \right] + \\ & + (1-\chi) \left[\mathbf{A}\bar{\mathbf{X}}_c(k+1)\cos\omega_{02}k\Delta t + \right. \\ & \left. + \mathbf{A}\bar{\mathbf{X}}_s(k+1)\sin\omega_{02}k\Delta t \right] + \bar{N}(k+1), \end{aligned} \quad (16)$$

where $\mathbf{A} = \|1, 1\|$; χ is a random variable and

$$\chi = \begin{cases} 1 & \text{with probability } P; \\ 0 & \text{with probability } Q = 1 - P; \end{cases}$$

P, Q are the *a priori* probabilities of transmission of $U_c^{(l)}(t)$ signals (in particular, $P=Q=0.5$); $\bar{N}(k+1)$ is normal white noise with a zero mean and a covariance function, $R_n(k, l) = \sigma_n^2 \delta_{k,l}$.

The optimal decisive rule by the criterion of an ideal observer for a priori equally probable transmitted signals in the time moment $T_a = n\Delta t$ is determined by inequality:

$$\Lambda[\bar{z}(n)] \stackrel{>}{<} 0, \quad (17)$$

where logarithm of the likelihood ratio is in a successive form:

$$\begin{aligned} \Lambda[\bar{z}(k+1)] &= \ln \left\{ \frac{w[\bar{z}(k+1)/\chi=1]}{w[\bar{z}(k+1)/\chi=0]} \right\} = \\ &= \Lambda[\bar{z}(k)] + \ln \left\{ \frac{w[\bar{z}(k+1)/\bar{z}(k), \chi=1]}{w[\bar{z}(k+1)/\bar{z}(k), \chi=0]} \right\}, \end{aligned} \quad (18)$$

while $\Lambda[\bar{z}(0)] = 0$.

A posteriori density of probabilities $w[\bar{z}(k+1)/\bar{z}(k), \chi]$ in expression (18) is Gaussian and, in this case, they take the form:

$$\begin{aligned} w[\bar{z}(k+1)/\bar{z}(k), \chi] &= \left\{ 2\pi \det[\mathbf{A}\mathbf{P}(k+1/k)\mathbf{A}^T + \sigma_n^2] \right\}^{-\frac{1}{2}} \times \\ &\times \exp \left\{ - \frac{\left\{ \begin{aligned} & \bar{z}(k+1) - \mathbf{A}\mathbf{\Phi}(k+1) \times \\ & \times [\dot{\bar{\mathbf{X}}}_c(k)\cos\omega_{01}k\Delta t + \dot{\bar{\mathbf{X}}}_s(k)\sin\omega_{01}k\Delta t] \end{aligned} \right\}^2}{2\pi[\mathbf{A}\mathbf{P}(k+1/k)\mathbf{A}^T + \sigma_n^2]} \right\}, \end{aligned} \quad (19)$$

where

$$\bar{\mathbf{X}}_A(k) = \|\dot{Y}_A(k), \dot{X}_A(k)\|^T; \quad \bar{\mathbf{X}}_s(k) = \|\dot{Y}_s(k), \dot{X}_s(k)\|^T$$

are the vectors of estimates of quadrature components of signal and concentrated interference, the procedure of their calculation is similar to the algorithm (15); $\mathbf{P}(k+1/k)$ is the transition matrix of estimation errors.

On the basis of expressions (17)–(19), we arrive at the following recurrent computing algorithm of joint detection and estimation:

$$\begin{aligned} & \sum_{k=0}^{n-1} \left\{ \bar{z}(k+1) - \mathbf{A}\mathbf{\Phi}(k+1) \times \right. \\ & \left. \times [\dot{\bar{\mathbf{X}}}_c(k)\cos\omega_{01}k\Delta t + \dot{\bar{\mathbf{X}}}_s(k)\sin\omega_{01}k\Delta t] \right\}^2 > \\ & > \sum_{k=0}^{n-1} \left\{ \bar{z}(k+1) - \mathbf{A}\mathbf{\Phi}(k+1) \times \right. \\ & \left. \times [\dot{\bar{\mathbf{X}}}_c(k)\cos\omega_{02}k\Delta t + \dot{\bar{\mathbf{X}}}_s(k)\sin\omega_{02}k\Delta t] \right\}^2. \end{aligned} \quad (20)$$

Under conditions of action of interferences with structures similar to that of the signal, it is necessary to carry out a separate successive estimation of signal and interference amplitudes without preliminary making decisions on reception of information symbols. To do this, one need to have information about functions of time auto-correlation of the manipulated signal and interference at the output of the radio communication channel.

Such estimation establishes the degree of influence of the ratio of the signal and interference manipulation speed, the rate of variation of characteristics of signal and interference propagation medium on quality of the radio channel. This will make it possible to provide recommendations on choosing optimal working frequencies of the radio communication system taking into account correlation properties of the channel, signal and interference.

4. Estimation of pulse response of the channel (action 4 in Fig. 3).

Estimation of pulse response at the k -th step for the MIMO radio channel will be represented by a matrix of weight factors of the focused neural network filter (FNNF) in the form:

$$H_{MIMO}(k) = \begin{bmatrix} W_i^{11}(k) & W_i^{12}(k) & \dots & W_i^{1N}(k) \\ W_i^{21}(k) & W_i^{22}(k) & \dots & W_i^{2N}(k) \\ \dots & \dots & \dots & \dots \\ W_i^{N1}(k) & W_i^{N2}(k) & \dots & W_i^{NN}(k) \end{bmatrix}, \quad (21)$$

where $W_i^{NN} = [w_0^{NN}, w_1^{NN}, \dots, w_{L-1}^{NN}]^T$ is the column vector of the reference pulse responses in the direction from the M_t -th transmitter to the M_r -th receiver.

5. Estimation of the bit error probability in the communication channel (action 5 in Fig. 3).

The results of measuring the bit error probability for a particular signal type are obtained in accordance with the mathematical relations obtained in [45].

6. Generalized estimate of the channel state (action 6 in Fig. 3).

When estimating the channel state (actions 3–5 in Fig. 3), a need arises to formulate a generalized estimate of state of the MIMO system channel.

Membership function [39–44] is the main instrument of fuzzy logic allowing one to convert expert’s knowledge IF-THEN into mathematical models.

For this task, it characterizes the degree of the expert’s confidence in the fact that some value belongs to the fuzzy concept (term). Methods of fuzzy logical inference make it possible to relate membership functions of indicators and the signal-interference situation in presence of the channel model in the form of IF-THEN rules.

$$a_i^p = \int_{\underline{x}_i}^{\bar{x}_i} \mu^{a_i^p}(x_i)/x_i, \tag{22}$$

$$d_j = \int_{\underline{d}}^{\bar{d}} \mu^{d_j}(d)/d. \tag{23}$$

Thus, the result of estimation of the communication channel state can be represented [39–44, 46] in the form:

$$y = f(x_1, x_2, \dots, x_n), \tag{24}$$

where x_1, x_2, \dots, x_n is a set of values of input indicators of the channel state; y is the result of the channel state estimation.

The region of variation of input indicators of the communication channel state, $x_i \in [\underline{x}, \bar{x}], i = 1, n$, and the output value of the result of estimation of the communication channel, $y \in [\underline{y}, \bar{y}]$, are presumed to be known. Here, $\underline{x}_i(\bar{x}_i)$ is the lower (upper) value of the input indicators $x_i, i = 1, n, \underline{y}(\bar{y})$ is the lower (upper) value of the result of identification, y .

Let $X^* = \langle x_1^*, x_2^*, \dots, x_n^* \rangle$ be the vector of fixed values of input indicators of the communication channel state where $x_i^* \in [\underline{x}_i, \bar{x}_i], i = 1, n$. The decision making problem consists in determining the result of the channel state estimation, $y^* \in Y$, based on information about the vector of input indicators, X^* . The necessary condition for formal solution of this problem is presence of dependence (24). To establish such dependence, it is necessary to represent the signal/interference environment and the initial decision on the generalized estimation of the channel state as linguistic variables specified in universal sets [29, 39–44, 46]:

$$X_i = [\underline{x}_i, \bar{x}_i], \tag{25}$$

$$Y = [\underline{y}, \bar{y}]. \tag{26}$$

To assess such linguistic variables, it is proposed to use qualitative terms that form a term-set [29, 39–44, 46]: $A_i = \{a_i^1, a_i^2, \dots, a_i^{g_i}\}$ is the term-set of the variable $x_i, i = 1, n, D = \{d_1, d_2, \dots, d_m\}$ is the term-set of the variable y , where a_i^p is the p -th linguistic term of the variable $x_i, p = 1, g_i, i = 1, n; d_j$ is the j -th linguistic term of the variable $y; m$ is the number of various solutions. Power of the term-sets can be different, that is ($g_1 \neq g_2 \neq \dots \neq g_n$). Names of terms $a_i^1, a_i^2, \dots, a_i^{g_i}$ may vary for different linguistic variables $x_i, i = 1, n$.

Linguistic terms $a_i^p \in A_i$ and $d_j \in D, p = 1, g_i, i = 1, n, j = 1, m$ should be considered as fuzzy sets specified in universal sets X_i, Y (25), (26).

Fuzzy sets a_i^p and d_j are determined by relations [29, 39–44, 46]:

$$a_i^p = \int_{\underline{x}_i}^{\bar{x}_i} \mu^{a_i^p}(x_i)/x_i, \tag{27}$$

$$d_j = \int_{\underline{d}}^{\bar{d}} \mu^{d_j}(d)/d, \tag{28}$$

where $\mu^{a_i^p}(x_i)$ is the membership function of the variable $x_i \in [\underline{x}, \bar{x}], i = 1, n$ of the term $a_i^p \in A_i, p = 1, g_i; \mu^{d_j}$ is the membership function of the variable $y \in [\underline{y}, \bar{y}]$ of the term-decision $d_j \in D, j = 1, m$. The integral symbols in relations (27) and (28) denote the union of $\mu(u)/u$ pairs.

Let N be the number of expert survey data relating the input indicators and the initial estimation of state of the communication channel. Distribute them as follows:

$$N = g_1 + g_2 + \dots + g_m,$$

where g_j is the number of expert data corresponding to the initial solution $d_j \in D, j = 1, m, m$ is the number of initial decisions when $g_1 \neq g_2 \neq \dots \neq g_m$.

The number of selected expert data is less than the complete enumeration of various combinations of levels of change of the input indicators of state of the MIMO system channel.

After enumeration, known expert data on the channel state can be represented as a matrix of knowledge [29, 39–44, 46] (Table 1).

Table 1

Fuzzy knowledge matrix

Number of the input combination of values	Input variables				Output variables
	x_1	x_2	x_i	x_n	Y
11	a_1^{11}	a_2^{11}	$\dots a_i^{11} \dots$	a_n^{11}	d_1
12	a_1^{12}	a_2^{12}	$\dots a_i^{12} \dots$	a_n^{12}	
...	
$1g_1$	$a_1^{1g_1}$	$a_2^{1g_1}$	$\dots a_i^{1g_1} \dots$	$a_n^{1g_1}$	
$j1$	a_1^{j1}	a_2^{j1}	$\dots a_i^{j1} \dots$	a_n^{j1}	d_i
$j2$	a_1^{j2}	a_2^{j2}	$\dots a_i^{j2} \dots$	a_n^{j2}	
...	
jg_j	$a_1^{jg_j}$	$a_2^{jg_j}$	$\dots a_i^{jg_j} \dots$	$a_n^{jg_j}$	
...
$m1$	a_1^{m1}	a_2^{m1}	$\dots a_i^{m1} \dots$	a_n^{m1}	d_m
$m2$	a_1^{m2}	a_2^{m2}	$\dots a_i^{m2} \dots$	a_n^{m2}	
...	
mg_m	$a_1^{mg_m}$	$a_2^{mg_m}$	$\dots a_i^{mg_m} \dots$	$a_n^{mg_m}$	

The matrix of knowledge is formed according to the following rules:

– dimensionality of such a matrix is equal to $(n+1) \times N$, where $(n+1)$ is the number of columns, $N = g_1 + g_2 + \dots + g_m$ is the number of rows;

– first n columns correspond to the input indicators of state of the MIMO system channel $x_i, i = 1, n$ and the $(n+1)$ -th column corresponds to the values d_j of the initial solution, $y, j = 1, m$;

– each row of the matrix represents a certain combination of input values of state of the MIMO system channel assigned by the expert to one of possible values of states d_j , with first g_j rows corresponding to the value d_1 , and the rest g_m of rows to the value d_m ;

– the item a_i^{jp} standing at intersection of the i -th column and the jp -th row corresponds to the linguistic estimate of the indicator x_i in the row of the fuzzy knowledge base with the number jp and the linguistic estimate a_i^{jp} is chosen from the term-set of the corresponding indicator x_i i. e. ($a_i^{jp} \in A, i = 1, n, j = 1, m, p = 1, l_j$).

Thus, expression (24) establishing connection between the input indicators, x_i , and the output estimate, y , was formalized into a system of logical expressions (30) based on a fuzzy knowledge base of the knowledge matrix (Table 1).

The process of generalized estimation of the communication channel can be graphically represented as in in Fig. 4.

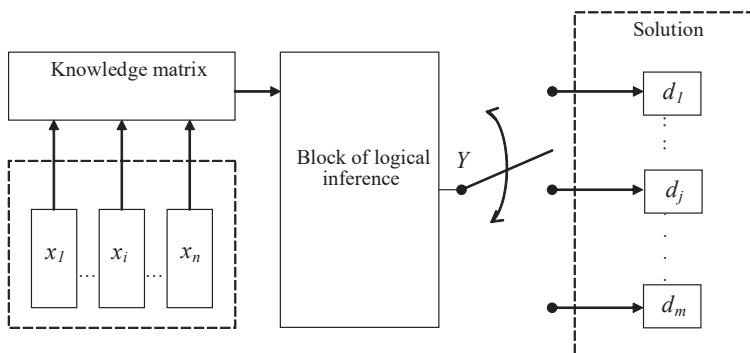

Fig. 4. Formation of a generalized estimate of the channel state

Proceeding from analysis of operation of the radio communication channel in different conditions of the signaled state, determine lines of the communication channel quality estimation.

These include similarity of indicators characterizing quality of the communication channel and changes during radio communication session up to the moment of making decision on quality of the communication channel.

Formation of a generalized estimate of state of a communication channel can be written as an equation:

$$D(k) = f \left[\begin{matrix} Y_1(k-1), \dots, Y_n(k-1), \\ Z_1(k-1), \dots, Z_n(k-1) \end{matrix} \right],$$

where $Y_1(k-1)$ is the vector characterizing the first indicator of quality of the communication channel at the $k-1$ -th step of estimation; $Y_n(k-1)$ is the vector characterizing the n -th indicator of quality of the communication channel at the $k-1$ -th step of simulation; $Z_1(k-1), \dots, Z_n(k-1)$ are the vectors characterizing the generalized estimate of the channel for each indicator of quality estimation of the communication channel.

In turn, vectors of quality estimation of the communication channel are characterized by the following indicators:

$$Y_1, \dots, Y_n, Z_1, \dots, Z_n = \{k_{11}(x), \dots, k_n(x)\}.$$

Possible states of the signaled situation in the channel are specified by the set $d \in \{d_1, d_2, d_3\}$, where d_1 means that the channel corresponds to the norm (to the maximum frequency efficiency); d_2 means that the individual channel

quality indicators are beyond the norm and require correction; d_3 means that the channel is unsuitable for operation. The estimation objective is to bring each of the combination of indicators of the signaling situation in line with one of solutions, $d_i, i = 1, 3$. Indicators $g_{11}, \dots, g_{21}, \dots, g_{141}, \dots, g_{145}$ will be considered as linguistic variables [29].

Formation of generalized estimation of quality of the communication channel can be represented as a multilevel logarithmic tree of logical inference which corresponds to the following states:

$$d = f_d(Z_1 \dots Z_n), \tag{29}$$

$$Z = f_z(Y_1 \dots Y_n), \tag{30}$$

$$Y_n = f_{y_n}(g_{n1}(x), g_{n2}(x), g_{n3}(x), g_{n4}(x), g_{n5}(x)). \tag{31}$$

For indicators with quantitative representation, the range of variation is divided into four quanta. This will enable transformation of a continuous universal set $U = [u, \bar{u}]$ into a discrete five-element set [29]:

$$U = \{u_1, u_2, \dots, u_5\},$$

where

$$u_1 = u, \quad u_2 = u + \Delta_1, \quad u_3 = u_2 + \Delta_2,$$

$$u_4 = u_3 + \Delta_3, \quad u_5 = u_4 + \Delta_4,$$

and $\Delta_1 + \Delta_2 + \Delta_3 + \Delta_4 = \bar{u} - u$, $\bar{u}(u)$ is the upper (lower) limit of the range of the indicator variation. Then all matrices of paired comparisons will have format 5×5 . The choice of four quanta is determined by the possibility of approximation of nonlinear curves by five points [29].

To assess values of linguistic variables, $g_{11}, \dots, g_{21}, \dots, g_{141}, \dots, g_{145}$, a scale of qualitative terms will be used. To assess linguistic variables D, Z_n, Y_n , the following term-sets will be used: $D, Z_1 \dots Z_n, Y_1 \dots Y_n = \{\text{the channel parameters are normal, some parameters of the channel go beyond the norm and require correction, the channel is unusable}\}$.

Each of the introduced terms is a fuzzy set specified by a corresponding membership function. In a general case, input variables x_1, x_2, \dots, x_n can be specified by a number, a linguistic term or by the principle of thermometer [29].

The communication channel is assessed using fuzzy logic equations [29] representing a matrix of knowledge and a system of logical propositions. These equations make it possible to calculate values of the membership functions of various estimation results at fixed values of input indicators. As a result of the estimation process, it is proposed to make a decision that has the greatest value of the membership function [29].

Linguistic estimates of α_i^{jp} variables x_1, x_2, \dots, x_n , contained in logical propositions relative to solutions $d_j, j = 1, m$ (27), (28) will be considered as the fuzzy sets defined on universal sets:

$$X_i = [x_i, \bar{x}_i], \quad i = \overline{1, n}.$$

Let $\mu^{\alpha_i^{jp}}(x_i)$ be the function of belonging of the indicator $x_i \in [x, \bar{x}]$ to fuzzy term $\alpha_i^{jp}, i = \overline{1, n}, j = \overline{1, m}, p = \overline{1, l_i}$;

$\mu^{d_j}(x_1, x_2, \dots, x_n)$ is the function of belonging of the vector of input variables $X = (x_1, x_2, \dots, x_n)$ to the initial estimate, $y = d_j, j = \overline{1, m}$. Relationship between these functions is determined by a fuzzy knowledge base and can be represented in the form of the following logical equations:

$$\begin{aligned} \mu^{d_j}(x_1, x_2, \dots, x_n) &= \mu^{a_1^{j1}}(x_1) \wedge \mu^{a_2^{j1}}(x_2) \wedge \dots \wedge \mu^{a_n^{j1}} \vee \\ &\vee \mu^{a_1^{j2}}(x_1) \wedge \mu^{a_2^{j2}}(x_2) \wedge \dots \wedge \mu^{a_n^{j2}}(x_n) \dots \\ &\dots \mu^{a_1^{jm}}(x_1) \wedge \mu^{a_2^{jm}}(x_2) \wedge \dots \wedge \mu^{a_n^{jm}}(x_n), j = \overline{1, m}. \end{aligned} \quad (32)$$

These equations are derived from the fuzzy knowledge base by replacing variables (linguistic terms) with the membership function and operations AND and OR with operations \wedge and \vee .

Write compactly the system (32) as follows:

$$\mu^{d_j}(x_i) = \bigvee_{p=1}^{l_j} \left[\bigwedge_{i=1}^n \mu^{a_i^{jp}}(x_i) \right], j = \overline{1, m}. \quad (33)$$

Fuzzy logical equations are analogous to the procedure of the fuzzy logical inference introduced by Zade [29, 39–44, 46] and realized by means of operations «fuzzy (min-max) composition» in which operations correspond to min and max operation [29, 39–44, 46] and the following will be obtained from (33):

$$\mu^{d_j}(x_i) = \max_{p=1, l_j} \left\{ \min_{j=1, n} \left[\mu^{a_i^{jp}}(x_i) \right] \right\}. \quad (34)$$

It is clear from expression (34) that there must be only functions of belonging variables to fuzzy terms to calculate the membership function. Consider the order of calculation of the membership function used in this procedure.

When choosing indirect methods of construction of a membership function which transform the expert information into a form convenient for application in channel estimation, it is necessary to take into account computational complexity of implementation. For example, to construct a membership function on the basis of the paired comparison method, it is necessary to form a matrix of paired comparisons and solve characteristic equations of the matrix of paired comparisons to determine its own vector. However, this method is computationally complicated. Given the possibility of calculating the membership function using rank ratings which are quite easy to obtain in an expert survey, we shall make use of the method of paired comparisons to calculate the membership function. The algorithm of calculation of the membership function of state of the communication channel includes the following stages:

1. Choose indicator of the communication channel quality to be assessed: $x_j, j = \overline{1, m}$.

2. Specify the set of fuzzy terms $\{u_1, u_2, \dots, u_l\}$, that is to be used for estimation of x .

3. Form a matrix of paired comparisons for each term, $u_i, i = \overline{1, l}$:

$$T = \begin{pmatrix} 1 & \frac{r_2}{r_1} & \frac{r_3}{r_1} & \dots & \frac{r_n}{r_1} \\ \frac{r_1}{r_2} & 1 & \frac{r_3}{r_2} & \dots & \frac{r_n}{r_2} \\ \dots & \dots & \dots & \dots & \dots \\ \frac{r_1}{r_n} & \frac{r_2}{r_n} & \frac{r_3}{r_n} & \dots & 1 \end{pmatrix}, \quad (35)$$

where $r_s(u_i)$ is the rank of the element $u_i \in U$, characterizing significance of this element in formation of properties which is described by some fuzzy term \tilde{S} .

The matrix (35) has the following properties:

– the elements of the main diagonal are equal to 1 ($t_{ij} = 1, i = \overline{1, n}$);

– relative to the main diagonal, the elements relate to expression $t_{ij} = 1/t_{ji}$;

– condition of transitivity is fulfilled: $t_{ig}t_{gj} = t_{ij}$, since

$$\frac{r_i}{r_g} \frac{r_g}{r_j} = \frac{r_i}{r_j}.$$

Due to the above properties, it is easy to find elements of other matrix rows by the known elements of one row, T . If elements $t_{gj}, g, j = \overline{1, n}$ are known, then any element t_{ij} is found as:

$$t_{ij} = t_{gj} / t_{gi}, i, j, g = \overline{1, n}.$$

Since the matrix (35) can be interpreted as a matrix of paired comparison of ranks, it is possible to use the 12-point Saati scale for the expert estimation of these matrix elements [46]. For the case:

$$t_{ij} = r_i / r_j = \begin{cases} 1 - \text{no advantage of } r_i \text{ over } r_j; \\ 3 - \text{small advantage of } r_i \text{ over } r_j; \\ 5 - \text{larger advantage of } r_i \text{ over } r_j; \\ 7 - \text{substantial advantage of } r_i \text{ over } r_j; \\ 9 - \text{clear cut advantage of } r_i \text{ over } r_j; \\ 11 - \text{absolute advantage of } r_i \text{ over } r_j; \\ 2, 4, 6, 8, 10 - \text{interim comparison evaluation.} \end{cases}$$

4. Membership functions are determined:

1) according to absolute estimates of ranks $r_i, i = \overline{1, n}$, that can be determined by a nine-point scale (1 is the lowest rank, 9 is the highest rank);

2) according to relative estimates of the ranks $r_i / r_j = t_{ij}, i, j = \overline{1, n}$, determined by the matrix of paired comparisons (35), the membership function for each term is calculated.

In this case, valuation of the obtained membership functions takes place by division into the highest degrees of membership.

The obtained ratios make it possible to calculate the membership function by means of rank ratings which is quite easy to obtain when using neuro-fuzzy networks.

When using a matrix of knowledge, known expert information about state of the MIMO system channel can be set in a form of a system of fuzzy logic propositions (35) relating the values of input indicators x_i with one of the possible solutions $d_j, j = \overline{1, m}$.

$$\begin{aligned} &IF(x_1 = \alpha_1^{11}) AND(x_2 = \alpha_2^{11}) AND \dots AND(x_n = \alpha_n^{11}) \\ &OR(x_1 = \alpha_1^{12})(x_2 = \alpha_2^{12}) AND \dots AND(x_n = \alpha_n^{12}) \\ &OR \dots OR(x_1 = \alpha_1^{1l})(x_2 = \alpha_2^{1l}) \\ &AND \dots AND(x_n = \alpha_n^{1l}), THEN y = d_m. \end{aligned}$$

$$\begin{aligned} &IF(x_1 = \alpha_1^{m1}) AND(x_2 = \alpha_2^{m1}) AND \dots AND(x_n = \alpha_n^{m1}) \\ &OR(x_1 = \alpha_1^{m2})(x_2 = \alpha_2^{m2}) AND \dots AND(x_1 = \alpha_n^{ml_n}) \\ &AND(x_2 = \alpha_2^{ml_n}) AND \dots AND(x_n = \alpha_n^{ml_n}) \\ &THEN y = d_m, \end{aligned} \quad (36)$$

where $d_j(j=1, \overline{m})$ is the linguistic estimate of the output variable y determined from the term-set D ; a_i^{jp} is the linguistic estimate of the input indicator x_i in the p -th row of the j -th disjunction chosen from the term-set A_i , ($i=1, n, j=1, m, p=1, k_j$); g_j is the number of rules determining value of the output variable, $y=d_j$.

Call the system (36) the fuzzy knowledge base used to form a set of estimates for each of indicators of the channel state estimation [46, 47].

The fuzzy logical relations (36) together with the membership function of fuzzy terms allow one to assess state of the communication channel by the following algorithm:

1. Fix values of quality indicators of the communication channel according to predefined criteria $X^*=(x_1^*, x_2^*, \dots, x_m^*)$.
2. Use the algorithm of calculation of the membership function to determine the membership function $\mu^j(x_i^*)$ at fixed values of indicators $x_i^*, i=1, m$.
3. Use logical equations (36) to calculate the membership function $\mu^{d_j}(x_1^*, x_2^*, \dots, x_m^*)$ at the vector of state $X^*=(x_1^*, x_2^*, \dots, x_m^*)$ for all states d_1, d_2, \dots, d_n . Replace logical operations *AND* (\wedge) and *OR* (\vee) over the membership functions with the min and max operations [29, 39–44, 46].
4. Determine solution d_j^* , for which:

$$d_j = \arg \max_{j=1, \overline{m}} (\mu d_j(x_i)).$$

These matrices form a fuzzy knowledge base for estimation quality of the communication channel [44].

Using tables and operations *AND* and *OR*, write the system of logical equations relating the membership functions of estimates of quality of the communication channel with the membership functions of destabilizing factors. Thus, if the values of the function of belonging to fuzzy terms are known, quality of the communication channel can be assessed by solving the logical equations described above. Application of the proposed hierarchical system of fuzzy logic equations results in the degree of membership of the communication channel state.

The output result of estimation and indicators of the communication channel quality represented as the linguistic variables assessed using fuzzy terms are specified in corresponding sets.

7. Calculation of estimation error and training of the neural network (action 7 in Fig. 3).

The principle of adaptive estimation of the communication channel parameters with the use of ANN is shown in Fig. 3. It implies the following. A known training discrete sequence $p(k)$ that comes to the ANN input is processed in ANN (neural network filter) which results in signal $y(k)$ at the output. This output signal is compared to the signal (reference) $d(k)$ that comes to the receiving side of the MIMO system and the difference between them forms an error signal $e(k)$ (filter discrepancy).

To correct the estimation values of the vector of weight factors (taps of the FNNF delay line), the following recursion is used:

$$\dot{W}(k+1) = \dot{W}(k) - \mu \nabla J(\dot{W}(k)) = \dot{W}(k) + 2\mu P^T(k)e(k), \quad (37)$$

where μ is the parameter of the FNNF training speed.

$$\begin{aligned} \nabla J(\dot{W}(k)) &= \frac{\partial e(k)}{\partial \dot{w}(k)} = \frac{\partial e(k)}{\partial d(k)} \frac{\partial d(k)}{\partial \dot{w}(k)} = -2P^T(k)d(k) + \\ &+ 2P^T(k)y(k) = -2P^T(k)(d(k) - y(k)) = -2P^T(k)e(k). \end{aligned} \quad (38)$$

In the theory of ANN, there are various ways of selecting the value of the training speed parameter, μ . Its value can remain constant or be adapted in the training process. Fixing of the value of the training speed parameter is considered to be the simplest form of determination. It has many drawbacks and is currently used relatively rarely. At the same time, this method remains the most effective in the process of FNNF training. A constant value of the training speed parameter is set in the range ($0 < \mu < 1$).

The task of the adaptive neural network filter is to minimize the error signal $e(k)$. To this end, a mechanism of adaptation (adjustment) of the weight factors of the neural network filter based on the analyzed error signal $e(k)$ is used.

The procedure for adaptation (adjustment) consists in finding unknown parameters that ensure adequacy of the neural network. To train the neural network, a reverse propagation method was used [39, 44]. An iteration of the training procedure consists of two stages: direct and reverse.

The first stage of the training procedure (the forward trace algorithm) has the following sequence of actions:

1. Calculate the total weighted input signal $p_j(k)$ of each neuron of the current neuron layer, t :

$$p_j(k) = \sum_{i=1}^{N_{t-1}} v_i w_{ij}. \quad (39)$$

2. Calculate the output signal $y_j(k)$ of each neuron of the current layer:

$$y_j(k) = \frac{1}{1 + e^{-kp_j(k)}}. \quad (40)$$

3. If the current layer is not output layer, then go to the next layer and repeat the procedure from step 1.
4. Calculate the error $e(k)$ of the neural network.

$$e(k) = \frac{1}{2} \sum_{j=1}^{N_K} (y_j(k) - \hat{d}_j(k))^2, \quad (41)$$

where $\hat{d}_j(k)$ is the reference value of the output of the j -th neuron of the output layer, N_K is the number of neurons in the output layer.

The second stage of the training procedure (reverse trace algorithm) has the following sequence of actions:

1. Determine rate of error variation when changing the output signal for each neuron of the output layer (*EA*):

$$EA_j^K = \frac{\partial e(k)}{\partial y_j(k)} = (\hat{d}_j(k) - y_j(k)). \quad (42)$$

2. Determine rate of error variation when changing the total input signal of each neuron of the current layer (*EI*):

$$EI_j^t = \frac{\partial e(k)}{\partial p_j(k)} = EA_j^t y_j(k) (1 - y_j(k)). \quad (43)$$

3. Determine rate of error variation when changing weight at the input connection of each neuron of the current layer (*EW*):

$$EW_{ij}^t = EI_j^t y_i(k). \quad (44)$$

4. Determine rate of error variation when changing activity of the previous layer neuron (*EA*):

$$EA_i^{i-1} = \frac{\partial e(k)}{\partial y_i(k)} = \sum_{j=1}^{N_i} EI_j^i w_{ij}, \quad (45)$$

where w_{ij} is the weight of the connection between the j -th neuron of the output layer and the i -th neuron of the input layer.

5. Modify connections between neurons according to the gradient rule:

$$w_{ij}[k+1] = w_{ij}[k] + \gamma E W_{ij}^1, \quad (46)$$

where γ is the training speed (iteration step); k is the training step number.

Go to the next layer.

6. If the specified layer is not the input layer, repeat all procedures from step 2.

Continue training until the acceptable error is reached.

Linear function was chosen as the function of activation in FNNF. By analogy with the digital filters, it enables calculation of the FNNF output in response to the input signal $p(k)$ and its previous values $p(k), \dots, p(k-L-1)$ by formula:

$$y(k) = \sum_{l=0}^{L-1} p(k-l) \dot{w}_l(k) = P^T(k) \dot{W}(k), \quad (47)$$

where

$$\dot{W}(k) = [\dot{w}_0(k), \dot{w}_1(k), \dots, \dot{w}_{L-1}(k)]^T$$

is the column vector of estimates of the weight factors of the generalized characteristic of the radio channel at the k -th step;

$$P(k) = [p(k), p(k-1), \dots, p(k-L-1)]^T$$

is the column vector of capacity of the FNNF delay line at the k -th step; L is the radio channel memory and the number of taps in the delay line at the FNNF input.

The process of obtaining estimates of state of the MIMO system channel is directly related to the FNNF training.

The vector of the training sequence $P(k)$ to which a countless number of implementations of the random scalar $d(k)$ correspond, collectively constitute training sample for the FNNF:

$$T = \{P(k), d(k)\}_{k=1}^{\Theta}, \quad (49)$$

where Θ is the training sequence length.

Error of estimation of the received signal $d(k)$ is:

$$e(k) = d(k) - y(k) = d(k) - P^T(k) \dot{W}(k). \quad (50)$$

Use the training criterion based on minimizing of the root mean square errors and take the following as an option of the estimation cost:

$$J(\dot{W}(k)) = E_T \{e^2(k)\}_{k=1}^{\Theta}, \quad (51)$$

where E_T is the operator of averaging throughout the training sample, T .

In order to obtain optimal estimates of the FNNF weight factors, use the well-known method of the fastest descent. To this end, it is necessary to calculate the instant gradient of the estimation error [39, 47].

Let us consider an example of generalized estimate of the communication channel state. Determination of the function of belonging to fuzzy terms according to the specified indicators is given in Table 2 and an example of formation of a generalized (integrated) estimate of the channel state is given in Table 3.

Table 2

Determination of the function of belonging to fuzzy terms according to the specified indicators of the channel state estimation

Values of indicators of channel state estimation	Universal set	Estimation terms	Value of the membership function
Pulse response	1–10	Normal state	0.91–1
		Beyond the norm	0.4–0.9
		Unusable channel	<0.3
Frequency response	1–10	Normal state	0.91–1
		Beyond the norm	0.4–0.9
		Unusable channel	<0.3
Probability of bit error	1–10	Normal state	0.91–1
		Beyond the norm	0.4–0.9
		Unusable channel	<0.3

Table 3

Example of formation of a generalized (integrated) estimation of the channel state

Values of indicators of the channel state estimation	Calculated membership functions	Decision of the channel state
Pulse response	0.080474451	Unusable channel. Numerous interferences in the entire band width of the channel. Probability of bit error is low but makes impossible the channel use for transmission of any type of data
Frequency response	0.080474451	
Probability of bit error	0.050553799	

5. 5. Estimation of efficiency of the proposed method

Four types of signals were used in modeling: with phase manipulation (PM-4 and PM-8), quadrature manipulation (QAM-16) and signal-code structures (SCS) with 8 states and 64 points in a constellation.

When modeling the method functioning, it was assumed that the method is concurrent when error $e(k)$ remained below -36 dB at 15 iterations of the generalized Viterbi algorithm [41].

The results of modeling the effect of the number of paths in each state M on the maximum permissible value of the inter-symbol interference are shown in Fig. 5 and Fig. 6 for the linear pulse response of the channel and the equally probable pulse response of the channel, respectively. It can be seen from the graphs that for all types of modeled signals, there is a certain limit value of the number of solutions for each state of the generalized Viterbi algorithm, Ξ , at which an increase in the number of its paths does not result in an increase in the maximum permissible value of the inter-symbol interference Σ .

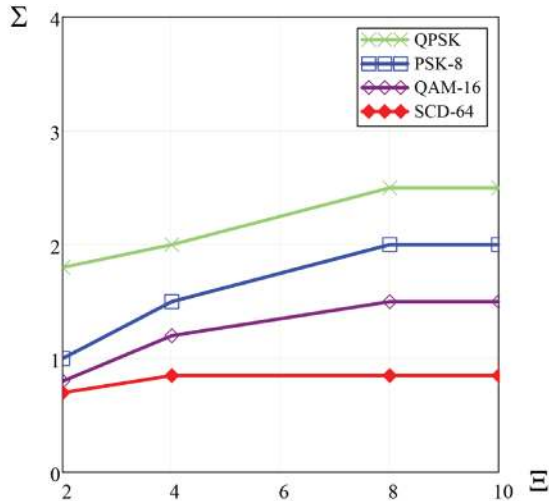

Fig. 5. Results of modeling the influence of the number of paths on the maximum permissible inter-symbol interference value for linear pulse response of the channel

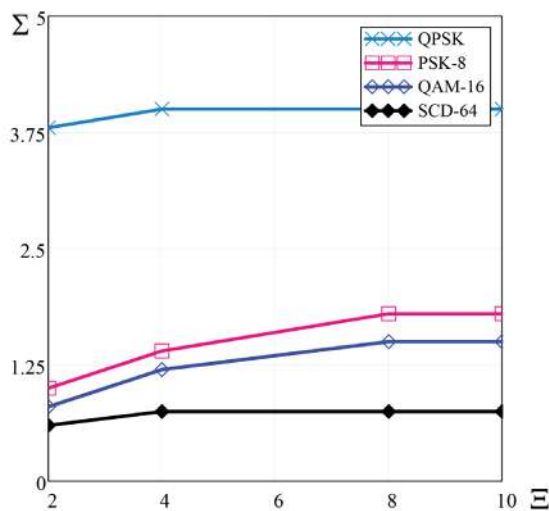

Fig. 6. Results of modeling the influence of the number of paths on the maximum permissible inter-symbol interference value for the equally probable pulse response of the channel

The following is brief description of the graphs shown in Fig. 7. The graphs for comparison of estimation of the values of state of the MIMO system channel obtained in the fuzzy model with reference values are shown in Fig. 7.

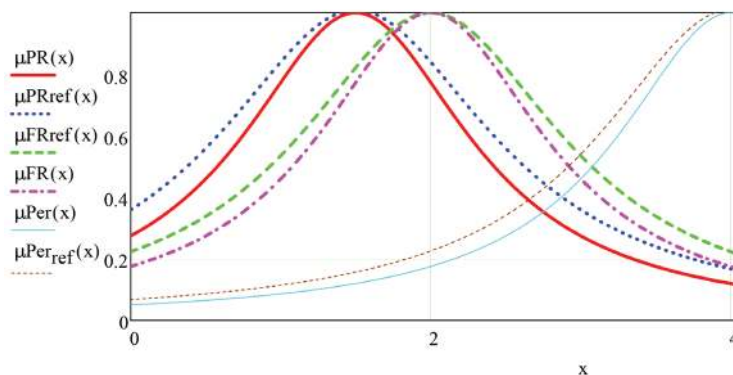

Fig. 7. Comparison of obtained values of the fuzzy model with reference (ref) values of indicators of the pulse response (PR) of the channel state, frequency response (FR) of the channel state and the bit error probability (P_{er})

Adequacy of the obtained fuzzy models to the reference models of estimation of the MIMO system gives the ground to state that the degree of divergence of the reference models of indicators of state of the communication channel of the MIMO system is 5–7 %.

Let us consider training of the neural network to be adaptable to the situation in the channel. Fig. 8 shows that the increase in the number of repetitions in training of the neural network decreases accuracy and final adaptation is reached after 10–11 repetitions.

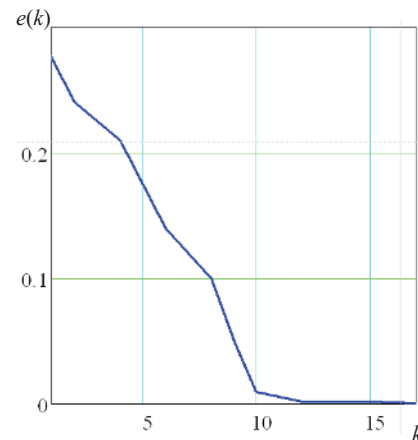

Fig. 8. Dependence of the neural network error on the number of training steps (iterations)

The following is the path of comparison of application of the proposed method and the known ones. The following initial data were used in modeling: MIMO system scheme: 8×8 ; modulation type: phase modulation; dimensionality of the signal ensemble $M=256$; type of the correcting codes: convolutional codes with rate $R=0.9$.

Zero Forcing (ZF) method, algorithm: optimal by the criterion of minimum mean square error (MMSE) and the method of maximum likelihood (ML) were taken for comparison.

Comparison of the developed method with known methods is shown in Fig. 9.

Comparison of the developed method with the known methods (Fig. 9) allows us to assert that the proposed method makes it possible to increase speed of estimation of state of the MIMO system channel by an average of 30 %, thereby increasing the interference immunity of multiantenna radio communication systems.

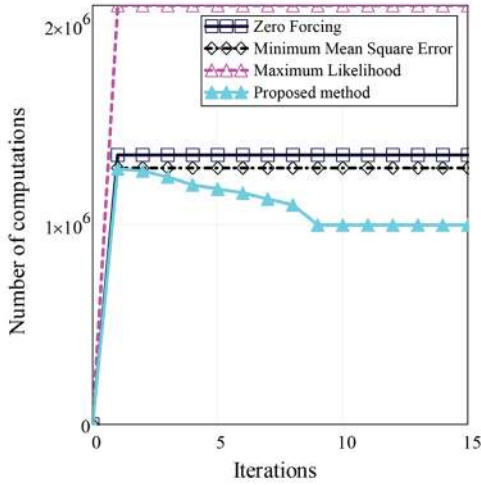

Fig. 9. Comparison of the computational complexity of the developed method and the known methods

Let us compare the developed method of integrated estimation of state of the MIMO system channel with known methods of estimation that use neural networks.

Fig. 10 shows dependences of the bit error on the signal/interference ratio for the developed integrated estimation method and the methods considered in studies [11, 12, 14, 15].

Systems were modeled in the signal/interference ratio range from -10 to +10 dB.

As can be seen from Fig. 10, the proposed integrated estimation method has somewhat less accuracy in estimation of the bit error probability in the channel compared to the methods specially developed for this estimation.

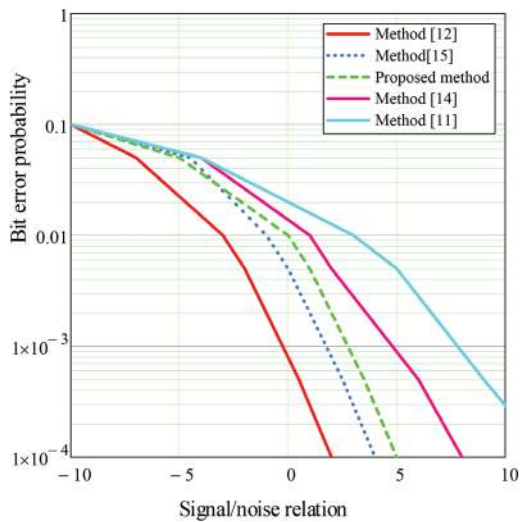

Fig. 10. Dependences of the bit error on the signal/interference ratio for the developed integrated estimation method and the methods considered in studies [11, 12, 14, 15]

5. 6. Practical recommendations for implementation of the proposed method in the radio communication facilities using the MIMO technology

Fig. 11 shows the mentioned focused neural network filter built on the basis of a linear adaptive adder and its work order in estimation of indicators of the communication chan-

nel state. Fig. 12 shows one of the variants of embodiment of the focused neural network filter for MIMO systems.

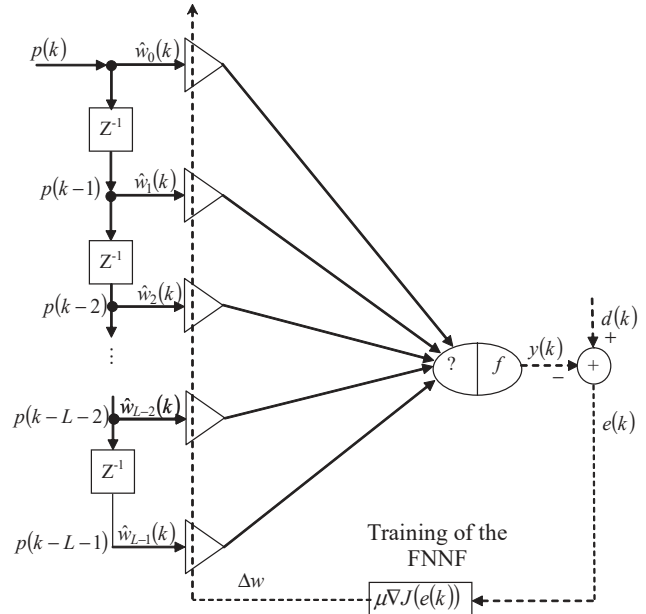

Fig. 11. Focused neural network filter based on a linear adaptive adder

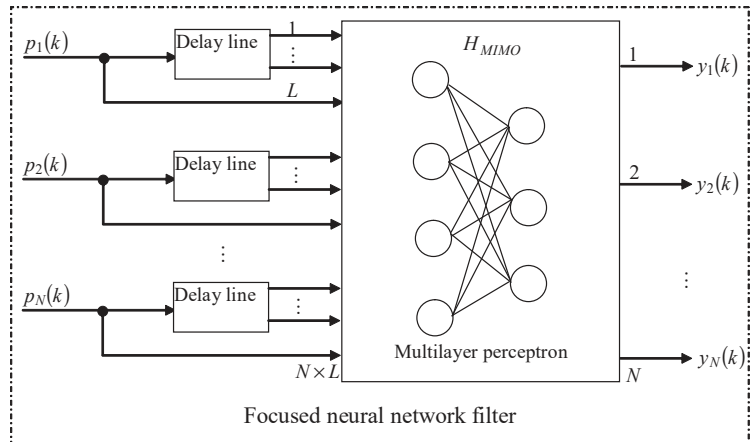

Fig. 12. Embodiment of SNF for the MIMO transmission system

6. Discussion of the results obtained in development of the method of integrated estimation of state of channels of multiantenna radio communication systems

In the framework of this paper, authors proposed a method for integrated estimation of state of channels of multiantenna radio communication systems. The proposed method was modeled in MathCad 14 software environment. The results of estimation of this method work are shown in Fig. 9 where it is evident that the proposed method, starting with the first iteration of its work, begins to demonstrate its advantage concerning the number of computational operations and reaches its maximum capacity after 10–11 iterations. While the proposed method is less complicated, it has lower accuracy of estimation because of use of the apparatus of fuzzy sets.

However, it is evident from analysis of Fig. 7 that the results of estimation of the channel state indicators obtained using the

membership function show a 6–8 % loss of informativity. This discrepancy is not critical, at the level of measurement error.

The main advantages of the proposed method of integrated estimation are:

- use of a complex indicator of estimation of the channel state taking into account majority of known estimation parameters;
- unambiguity of obtained estimation of the channel state;
- wide scope of use (radio communication and radar systems);
- simplicity of mathematical calculations;
- possibility of adaptation to the signaling situation in the channel;
- possibility of synthesizing the optimal structure of the radio communication facility.

Disadvantages of the proposed method of integrated estimation include:

- loss of informativity in estimation of the channel state because of membership function construction. This loss of informativity can be reduced by a choice of type of membership function in a practical implementation of the proposed method in radio communication facilities. The choice of the membership function type depends on the computation resources of a particular radio facility;
- lower accuracy of estimation for the separately taken parameter of estimation of the channel state;
- smaller precision of estimation at the initial stage because of untrained neural network and absence of a signaling base;
- it is not advisable to use this method in radio communication systems if it is necessary to obtain an accurate estimation of the channel state for an individual indicator.

It is appropriate to use this method in radio stations with programmable architecture operating in conditions of active radio-electronic jamming. This method will ensure:

- identification of interference structure, type and the law of setting;
- estimation of the channel state;
- use of efficient signal-code designs to ensure the channel interference immunity;
- efficient use of the radio frequency resource of programmable radio communication facilities;
- increase speed of estimation of communication channels;
- reduce consumption of computation resources of the radio communication facilities with a programmable architecture;
- develop measures aimed at improvement of the interference immunity.

It is advisable to apply the proposed method in developing software in the modules (blocks) of estimation of promising radio communication facilities based on the open interface architectures of SCA 2.2 version.

A block diagram of the radio communication facility was developed with the use of the FNNF channel for state estimation and the method for estimation of the signaling situation which are protected by the patents of Ukraine on utility models [49, 50].

This study is further development of the authors' study aimed at development of methodological principles of op-

erational management of radio resources of radio communication systems.

7. Conclusions

1. The method of integrated estimation of the state of multiantenna systems based on the use of the apparatus of fuzzy sets and artificial neural networks was proposed which enables obtaining of precise solutions with sufficient simplicity.

The distinguishing features of the proposed method are as follows:

- state of the communication channel is estimated in parallel for several indicators (pulse response, frequency response and the bit error probability);
- estimation of several characteristics of the channel state constantly in real time;
- estimation of several characteristics of the channel state in the channel down and channel upward;
- the channel state is assessed for each indicator in a separate layer of the neural network with the help of construction of a membership function;
- after estimation of a separate channel characteristic in a separate layer of the neural network, a generalized estimation of the channel state is formed at its output.

The estimates obtained with application of the proposed method of integrated estimation coincide with the results obtained with the use of an algorithm optimal by the criterion of minimal root mean square error. At the same time, these results are calculated up to 30 % faster which reduces adaptation time of the radio communication facility. The factor determining effectiveness of the proposed integrated method is the degree of training of the neural network to the signaling environment.

2. In order to reduce time of training of the neural network and improve efficiency of the proposed method, it is expedient to download the knowledge base of the signal situation in advance. This will minimize the time for network training and simplify the process of adaptation of the radio communication facilities by an average of 15 %.

3. The proposed method of integrated estimation of channel state in multiantenna radio communication systems can be implemented in radio communication facilities with a programmable architecture. To do this, it is necessary to adapt the signal processor by means of additional software for a specific radio communication facility. It is expedient to develop the above-mentioned software on the SCA 2.2 platform.

Acknowledgment

The authors express their thanks for assistance to:

Prof. Vadim Sliusar, Honored Worker of Science and Technology of Ukraine, Doctor of Technical Sciences, Chief Scientific Associate of the Central Research Institute of Arms and Military Equipment of the Armed Forces of Ukraine.

Prof. Alexander Rotshtein, Doctor of Technical Sciences, Professor of the Jerusalem Mahon Lev Polytechnic Institute.

References

1. Slyusar V. Cistemy MIMO: principy postroeniya i obrabotka signalov // Elektronika: Nauka, Tekhnologiya, Biznes. 2005. Issue 8. P. 52–58.
2. Kuvshynov O. V. Adaptivne upravlinnia zasobamy zavadozakhystu viyskovykh system radiozviazku // Zbirnyk naukovykh prats VIKNU. 2009. Issue 17. P. 125–130.

3. Dahiya S., Singh A. K. Channel estimation and channel tracking for correlated block-fading channels in massive MIMO systems // *Digital Communications and Networks*. 2018. Vol. 4, Issue 2. P. 138–147. doi: <https://doi.org/10.1016/j.dcan.2017.07.006>
4. Khan I., Singh D. Efficient compressive sensing based sparse channel estimation for 5G massive MIMO systems // *AEU – International Journal of Electronics and Communications*. 2018. Vol. 89. P. 181–190. doi: <https://doi.org/10.1016/j.aue.2018.03.038>
5. Vovchenko V. S. Statistical estimation of losses in communication channels of standard lte and lte-advanced on the basis of technology MIMO // *Systemy obrobky informatsiyi*. 2015. Issue 7 (132). P. 159–163.
6. Mardoyan G. R. MIMO channel estimation for pseudo-coherent communication systems // *V mire nauchnykh otkrytiy*. 2015. Issue 2 (62). P. 465–478. doi: <https://doi.org/10.12731/wsd-2015-2-27>
7. Chiong C. W. R., Rong Y., Xiang Y. Blind channel estimation and signal retrieving for MIMO relay systems // *Digital Signal Processing*. 2016. Vol. 52. P. 35–44. doi: <https://doi.org/10.1016/j.dsp.2016.02.007>
8. Dynamic propagation characteristics estimation and tracking based on an EM-EKF algorithm in time-variant MIMO channel / Wang Y., Chen K., Yu J., Xiong N., Leung H., Zhou H., Zhu L. // *Information Sciences*. 2017. Vol. 408. P. 70–83. doi: <https://doi.org/10.1016/j.ins.2017.04.035>
9. Kuhn V. *Wireless Communications over MIMO Channels: Applications to CDMA and Multiple Antenna Systems*. Chichester, United Kingdom: John Wiley Sons, 2006. 363 p.
10. Shaheen E. M., Samir M. Jamming Impact on the Performance of MIMO Space Time Block Coding Systems over Multi-path Fading Channel // *REV Journal on Electronics and Communications*. 2013. Vol. 3, Issue 1-2. doi: <https://doi.org/10.21553/rev-jec.56>
11. Bandwidth variable transceivers with artificial neural network-aided provisioning and capacity improvement capabilities in meshed optical networks with cascaded ROADM filtering / Zhou X., Zhuge Q., Qiu M., Xiang M., Zhang F., Wu B. et. al. // *Optics Communications*. 2018. Vol. 409. P. 23–33. doi: <https://doi.org/10.1016/j.optcom.2017.09.021>
12. Sarma K. K., Mitra A. Modeling MIMO channels using a class of complex recurrent neural network architectures // *AEU – International Journal of Electronics and Communications*. 2012. Vol. 66, Issue 4. P. 322–331. doi: <https://doi.org/10.1016/j.aue.2011.08.008>
13. Seyman M. N., Taspinar N. Channel estimation based on neural network in space time block coded MIMO–OFDM system // *Digital Signal Processing*. 2013. Vol. 23, Issue 1. P. 275–280. doi: <https://doi.org/10.1016/j.dsp.2012.08.003>
14. Zhang L., Zhang X. MIMO channel estimation and equalization using three-layer neural networks with feedback // *Tsinghua Science and Technology*. 2007. Vol. 12, Issue 6. P. 658–662. doi: <https://doi.org/10.1109/tst.2007.6071814>
15. Gogoi P., Kumar Sarma K. Channel Estimation Technique for STBC coded MIMO System with Multiple ANN Blocks // *International Journal of Computer Applications*. 2012. Vol. 50, Issue 13. P. 10–14. doi: <https://doi.org/10.5120/7830-1018>
16. Neumann D., Wiese T., Utschick W. Learning the MMSE Channel Estimator // *IEEE Transactions on Signal Processing*. 2018. P. 1–1. doi: <https://doi.org/10.1109/tsp.2018.2799164>
17. Deep Learning-based Channel Estimation for BeamSpace mmWave Massive MIMO Systems / He H., Wen C.-K., Jin S., Li G. Y. // *IEEE Wireless Communications Letters*. 2018. P. 1–1. doi: <https://doi.org/10.1109/lwc.2018.2832128>
18. Nayal N., Sharma K. Channel Estimation in Long Term Evolution // *International Journal of Computer Science And Technology*. 2015. Vol. 6, Issue 3. P. 230–234.
19. Cai J., Li Y., Hu Y. Deep convolutional neural network based antenna selection in multiple-input multiple-output system // *Young Scientists Forum 2017*. 2018. doi: <https://doi.org/10.1117/12.2317603>
20. Reshamwala N. S., Suratia P. S., Shah S. K. Artificial Neural Network trained by Genetic Algorithm for Smart MIMO Channel Estimation for Downlink LTE-Advance System // *International Journal of Computer Network and Information Security*. 2014. Vol. 6, Issue 3. P. 10–19. doi: <https://doi.org/10.5815/ijcnis.2014.03.02>
21. Malik S., Kumar S. Optimized Phase Noise Compensation Technique using Neural Network // *Indian Journal of Science and Technology*. 2017. Vol. 10, Issue 5. P. 1–6. doi: <https://doi.org/10.17485/ijst/2017/v10i5/104348>
22. Zhang P., Chen S., Hanzo L. Two-Tier Channel Estimation Aided Near-Capacity MIMO Transceivers Relying on Norm-Based Joint Transmit and Receive Antenna Selection // *IEEE Transactions on Wireless Communications*. 2015. Vol. 14, Issue 1. P. 122–137. doi: <https://doi.org/10.1109/twc.2014.2334325>
23. Predicting Wireless MmWave Massive MIMO Channel Characteristics Using Machine Learning Algorithms / Bai L., Wang C.-X., Huang J., Xu Q., Yang Y., Goussetis G. et. al. // *Wireless Communications and Mobile Computing*. 2018. Vol. 2018. P. 1–12. doi: <https://doi.org/10.1155/2018/9783863>
24. Khan I., Singh M., Singh D. Compressive Sensing-based Sparsity Adaptive Channel Estimation for 5G Massive MIMO Systems // *Applied Sciences*. 2018. Vol. 8, Issue 5. P. 754. doi: <https://doi.org/10.3390/app8050754>
25. Tang R., Zhou X., Wang C. A Haar Wavelet Decision Feedback Channel Estimation Method in OFDM Systems // *Applied Sciences*. 2018. Vol. 8, Issue 6. P. 877. doi: <https://doi.org/10.3390/app8060877>
26. Pilot reduction techniques for sparse channel estimation in massive MIMO systems / Kulsoom F., Vizziello A., Chaudhry H. N., Savazzi P. // *2018 14th Annual Conference on Wireless On-demand Network Systems and Services (WONS)*. 2018. doi: <https://doi.org/10.23919/wons.2018.8311671>
27. Kumari D. L., Prasa M. N. A review paper on performance analysis of mimo based ofdma system under fading channel // *International Journal of Electronics and Communication Engineering and Technology (IJECET)*. 2017. Vol. 8, Issue 1. P. 32–42.
28. Kuvshynov O. V. Alhorytmy kontroliu stanu kanalu zviazku v umovakh skladnoi radioelektronnoi obstanovky // *Systemy ozbroienia i viyskova tekhnika*. 2011. Issue 2 (26). P. 189–192.

29. Zhyvotovskiy R., Shyshatskiy A., Petruk S. Structural-semantic model of communication channel // 2017 4th International Scientific-Practical Conference Problems of Infocommunications. Science and Technology (PIC S&T). 2017. doi: <https://doi.org/10.1109/infocommst.2017.8246454>
30. Slyusar V. I., Slyusar I. I. Sovmestnoe ocenivanie neskol'kih parametrov signalov v sistemah svyazi s cifrovym diagrammoobrazovaniem // Materialy 7-go yubileynogo mezhdunarodnogo molodezhnogo foruma «Radioelektronika i molodezh' v XXI veke». Kharkiv, 2003. P. 128.
31. Digital Transmission: Carrier-to-Noise Ratio, Signal-to Noise Ratio and Modulation Error Ratio. White Paper, Cisco, 2006.
32. Batch processing algorithms for blind equalization using higher-order statistics / Chi C.-Y., Chen C.-Y., Chen C.-H., Feng C.-C. // IEEE Signal Processing Magazine. 2003. Vol. 20, Issue 1. P. 25–49. doi: <https://doi.org/10.1109/msp.2003.1166627>
33. Jitendra K. T., Tong L., Ding Z. Single-User Channel Estimation and Equalization // IEEE Signal Processing Magazine. 2000. P. 17–28.
34. Shyshatskiy A. V., Liutov V. V. Analiz isnuuiuchykh metodiv otsinky stanu kanalu zviazku // VI Naukovo-tehnicna konferentsiya «Problemni pytannia rozvytku ozbroiennia ta viyskovoï tekhniky». Kyiv, 2015. P. 398.
35. Gu Q. RF System Design of Transceivers for Wireless Communications. Springer, 2005. doi: <https://doi.org/10.1007/b104642>
36. Hranac R. Broadband: Is MER Overrated? // Communications Technology. 2017.
37. Mahmoud H. A., Arslan H. Error vector magnitude to SNR conversion for nondata-aided receivers // IEEE Transactions on Wireless Communications. 2009. Vol. 8, Issue 5. P. 2694–2704. doi: <https://doi.org/10.1109/twc.2009.080862>
38. Coded Modulation Library. URL: <http://www.iterativesolutions.com/>
39. Rotshteyn A. P. Intel'ektual'nye tekhnologii identifikacii: nechetkie mnozhestva, geneticheskie algoritmy, neyronnye seti. Vinnyca: «UNIVERSUM», 1999. 320 p.
40. Shmatok S. O., Podchashynskiy Yu. O., Shmatok O. S. Matematychni ta prohramni zasoby modeliuвання prystroiv i system upravlinnia. Vykorystannia nechetkykh mnozhyn ta neyronnykh merezh: navch. pos. Zhytomyr: ZhDTU, 2007. 280 p.
41. Parashchuk I. B., Ivanov Yu. N., Romanenko P. G. Neyrosetevye metody v zadachah modelirovaniya i analiza effektivnosti funkcionirovaniya setey svyazi. Sankt Peterburg: BAC, 2010. 104 p.
42. Haykin S. Neyronnye seti: polniy kurs. 2-e izd. Moscow: Vil'yams, 2006. 1104 p.
43. Andrews J. G. Modulation, coding and signal processing for wireless communications – Interference cancellation for cellular systems: a contemporary overview // IEEE Wireless Communications. 2005. Vol. 12, Issue 2. P. 19–29. doi: <https://doi.org/10.1109/mwc.2005.1421925>
44. Capacity limits of MIMO channels / Goldsmith A., Jafar S. A., Jindal N., Vishwanath S. // IEEE Journal on Selected Areas in Communications. 2003. Vol. 21, Issue 5. P. 684–702. doi: <https://doi.org/10.1109/jsac.2003.810294>
45. Method of estimation of the parameters of signals with digital modulation types / Shishatskiy A. V., Zhuk O. G., Lutov V. V., Zhivotovsky R. M. // Nauka i tekhnika Povitrianykh Syl Zbroinykh Syl Ukrainy. 2016. Issue 4 (25). P. 117–121.
46. Rassel S., Norvig P. Iskusstvenniy intellekt: sovremenniy podhod. Moscow: Izdatel'skiy dom «Vil'yams», 2006. 1408 p.
47. Neyronnye seti. URL: <http://neurocomp.ru/2009/07/01/nejronnye-seti/>
48. Shushkevich G. Ch., Shushkevich S. V. Vvedenie v MathCAD 2000: ucheb. pos. Grodno, 2001. 138 p.
49. Sliusar V. I., Hatsenko S. S., Shyshatskiy A. V. Sposib otsiniuvannia syhnalnoi obstanovky v umovakh nevyznachenosti: Pat. No. 123110 UA. No. u201708576; declared: 21.08.2017; published: 12.02.2018, Bul. No. 3.
50. Systema z mnozhynoiu vkhodiv ta mnozhynoiu vykhodiv (MIMO) pidvyshchenoi zavadozakhyshchenosti: Pat. No. 113747 UA / Chumak V. K., Shyshatskiy A. V., Karlov V. D., Zhyvotovskiy R. M., Romanenko I. O., Kuvshynov O. V. No. u201608699; declared: 10.08.2016; published: 10.02.2017, Bul. No. 3.