

## Micro-optofluidic lenses : a review

Nguyen, Nam-Trung

2010

Nguyen, N. T. (2010). Micro-optofluidic Lenses: a review. *Biomicrofluidics*, 4(3).

<https://hdl.handle.net/10356/94752>

<https://doi.org/10.1063/1.3460392>

---

© 2010 American Institute of Physics. This paper was published in *Biomicrofluidics* and is made available as an electronic reprint (preprint) with permission of American Institute of Physics. The paper can be found at the following official URL: [<http://dx.doi.org/10.1063/1.3460392>]. One print or electronic copy may be made for personal use only. Systematic or multiple reproduction, distribution to multiple locations via electronic or other means, duplication of any material in this paper for a fee or for commercial purposes, or modification of the content of the paper is prohibited and is subject to penalties under law.

*Downloaded on 25 Aug 2022 03:37:36 SGT*

## Micro-optofluidic Lenses: A review

Nam-Trung Nguyen<sup>a)</sup>

*School of Mechanical and Aerospace Engineering, Nanyang Technological University,  
50 Nanyang Avenue, Singapore, 639798*

(Received 26 February 2010; accepted 8 June 2010; published online 19 July 2010)

This review presents a systematic perspective on the development of micro-optofluidic lenses. The progress on the development of micro-optofluidic lenses are illustrated by example from recent literature. The advantage of micro-optofluidic lenses over solid lens systems is their tunability without the use of large actuators such as servo motors. Depending on the relative orientation of light path and the substrate surface, micro-optofluidic lenses can be categorized as in-plane or out-of-plane lenses. However, this review will focus on the tunability of the lenses and categorizes them according to the concept of tunability. Micro-optofluidic lenses can be either tuned by the liquid in use or by the shape of the lens. Micro-optofluidic lenses with tunable shape are categorized according to the actuation schemes. Typical parameters of micro-optofluidic lenses reported recently are compared and discussed. Finally, perspectives are given for future works in this field. © 2010 American Institute of Physics. [doi:10.1063/1.3460392]

### I. INTRODUCTION

With applications ranging from mobile phone to laboratory on a chip, miniature lenses have been attracting attentions from research communities of both microfluidics and micro-optics. Liquid lenses have emerged as a promising candidate for miniaturization of imaging optics. Liquid lenses have a number of apparent advantages such as tunable refractive index and reconfigurable geometry. Furthermore, the control and actuation of the lens liquid benefit from the recent advances in microfluidics. The combination of micro-optics and microfluidics leads to the new research discipline of micro-optofluidics that utilizes the interactions between fluids, fluid flows, and light to create new functional optical as well as microfluidic devices. Micro-optofluidic lens is one of these novel devices. Excellent reviews on optofluidics were published recently by Psaltis *et al.*,<sup>1</sup> Monat *et al.*,<sup>2,3</sup> Hunt and Wilkinson,<sup>4</sup> Levy and Erickson *et al.*,<sup>5</sup> as well as Shamaï.<sup>6</sup> Micro-optofluidic lenses were mentioned in these reviews but not in the necessary depth needed for researchers working on designing and implementing microfluidic lenses.

Micro-optofluidic lenses are considered in this review as lenses that use liquid as the optical medium and microfluidic techniques as a mean for manipulation and actuation. Depending on the relative arrangement between the optical path and the substrate plane, micro-optofluidic lenses can be categorized as in-plane and out-of-plane lenses. While the light path of in-plane lenses is in the plane of the device substrate, out-of-plane lenses manipulate light paths perpendicular to this plane. Out-of-plane lenses are compatible to conventional fixed lens and could replace them in applications such as digital camera and cell phones. However, the fabrication process of out-of-plane lenses is more complex. These lenses require precise alignment of the different optical layers. In-plane lenses are suitable for laboratory-on-a-chip applications because they can be integrated with the microfluidic network that performs the sample analysis. Due to this compatibility to microfluidics, in-plane lenses promise a higher integration density and a higher degree of complexity.

---

<sup>a)</sup>Electronic mail: mntnguyen@ntu.edu.sg.

TABLE I. Comparison between optofluidic tuning and other optical tuning techniques [ $\mathcal{O}(\Delta n/n)$ : order of magnitude of the relative change in refractive index,  $\mathcal{O}(\tau)$ : order of magnitude of time response, after Ref. 5].

Tuning techniques	$\mathcal{O}(\Delta n/n)$	$\mathcal{O}(\tau)$ (s)
Optofluidics	1	$10^{-3}$
Liquid crystal	$10^{-1}$	$10^{-3}$
Injection current	$10^{-2}$	$10^{-9}$
Temperature	$10^{-2}$	1
Photorefractive	$10^{-3}$	$10^{-1}-10^{-5}$
Electro-optic (10 kV/cm)	$10^{-3}$	$10^{-12}$
Photoelastic/acousto-optic (10 W)	$10^{-4}$	$10^{-6}-10^{-7}$

Micro-optofluidic lenses can be tuned by either refractive index or geometry.<sup>6</sup> Refractive index of the liquid in a micro-optofluidic device can be modulated to change the phase, the amplitude, and the polarization of the light passing through the lens. Although the refractive index can be modified by different means such as pressure control, electrowetting control, optical control, magnetic control, thermo-optic control, and electro-optic control,<sup>6</sup> the most common and simple way is to fill the lens with different liquids. Concentration of a solution can also be used for controlling the refractive index. The geometry of the lens can be modulated by a variety of concepts known in microfluidics. If the lens is formed with the liquid/solid interface of a flexible material such as polydimethylsiloxane (PDMS), the shape can be controlled by applying pressure. If the lens is formed with liquid/liquid or air/liquid interfaces, the shape can be controlled by means of hydrodynamics, electrowetting, or other physical effects. In this review, micro-optofluidic lenses are categorized and discussed based on the tunability of the liquid and the shape of the lens.

## II. TUNABILITY WITH LENS LIQUID

As mentioned above, micro-optofluidic lenses can be tuned by manipulating the refractive index of its liquid. Conventional optical tuning techniques change the refractive index by subjecting the liquid to an external electrical field, acoustic field, temperature field, or mechanical strain.<sup>5</sup> Microfluidic techniques such as pumping and mixing can be used for changing the lens liquid or its composition. If the lens liquid is a mixture, the composition can be adjusted by integrating a concentration generator and mixer on the same platform of the lens. The time response  $\tau$  of microfluidic manipulation is on the order of milliseconds. Since the entire liquid of lens can be changed, a large relative change in refractive index  $\mathcal{O}(\tau)$  can be achieved. For the extreme case of replacing air by a liquid, a relative change of  $\mathcal{O}(\tau) \sim 1$  can be achieved. None of the previous optical tuning techniques can achieve this high relative change of refractive index. Table I lists the performance of the different tuning techniques.<sup>5</sup> Compared to conventional tuning techniques, micro-optofluidic tuning is only faster than thermal tuning. In many applications, the lens is formed by the liquid/liquid interface of coflowing streams; the changing speed of the liquid streams depends on external or integrated pumps or valves. Thus, the time response could be on the order of seconds.

Table II lists some common liquids used for micro-optofluidic lenses. Since a number of microfluidic as well as micro-optofluidic devices were made in PDMS, the refractive index of PDMS of 1.412 is taken as the reference for choosing the right liquids for the lens. The smoothness of the device surface depends on the quality of the photolithography mask and the microfabrication process. In general, the solid surface in a microfluidic or micro-optofluidic device cannot compete with the surface of conventional optical components. Only a liquid/liquid or an air/liquid interface can create an atomically smooth surface. To minimize scattering effects at the solid/liquid interface, the cladding liquid in a micro-optofluidic system should have a refractive index match-

TABLE II. Common liquids and their properties at 25 °C, 100 kPa ( $n$ : refractive index,  $\mu$ : dynamic viscosity,  $\rho$ : density,  $\sigma$ : surface tension, CAS: chemical abstract services).

Liquids	CAS code	$n$	$\mu$ (mPa s)	$\rho$ (kg/m <sup>3</sup> )	$\sigma$ (mN/m)
Trifluoroethanol	75-89-8	1.291	1.24	1382	20
DI-water	7732-18-5	1.33	0.89	997	73
Isopropanol	67-63-5	1.33	1.96	786	23
Methanol	67-561	1.33	0.59	787	23
Ethanol	64-17-5	1.36	1.04	789	22
Silicone oil	63148-62-9	1.375–1.405	0.494–976	760–976	16–22
Cured PDMS	...	1.412			
73.5% ethylene glycol, 26.5% ethanol	...	1.412	9.80	915	33
60% glycerol, 40% water	...	1.412	8.99	1151	56
Ethylene glycol	107-21-1	1.43	16.1	960	47.3
5M CaCl <sub>2</sub> solution	...	1.44–1.46	9.00	1396	...
Benzyl alcohol	100-51-6	1.54	8.00	1044	39
Cinnamaldehyde	104-55-2	1.62	5.70	1050	36
Benzothiazole	95-16-9	1.64	...	1272	54

ing to that of cured PDMS. Table II lists two examples of index-matching solutions: 73.5 wt % ethylene glycol with 26.5 wt % ethanol or 60 wt % glycerol with 40 wt % water. Both mixtures have comparable dynamic viscosity and density. However the first mixture has a lower surface tension. With an index-matching liquid as cladding, a lens liquid with a lower or a higher refractive index can be chosen. Most liquids with high refractive indices are organic compounds with possible health hazards, while common liquids such as water and ethanol have lower refractive index than PDMS. So the use of low refractive index is desirable for designing a micro-optofluidic lens. Conventional optical components are designed with the assumption that the refractive index of the optical material is higher than the surrounding medium (air). For instance, a biconvex lens with high refractive index has a focusing effect. With PDMS and the index-matching liquid as the surrounding medium, there are opportunities to design optical components with low refractive index such as a biconcave lens for focusing light.<sup>7</sup> A relatively safe liquid with high reflective index is cinnamaldehyde ( $n=1.62$ ). Cinnamaldehyde is the organic compound that can be extracted from cinnamon. This liquid has a comparable viscosity as the index-matching mixture mentioned above. Furthermore, cinnamaldehyde is only slightly soluble in water and ethanol. Thus, it is easy to form a stable flow of almost immiscible interface with these liquids.

Another unique property of liquid as optical material is controlled diffusion of species. At laminar flow condition in microfluidics, the concentration distribution of species is determined by molecular diffusion. Thus, a concentration gradient or a refractive index gradient can be generated in the optical material. Taking the solution of calcium chloride CaCl<sub>2</sub> as an example, a refractive index from 1.33 to 1.44 can be adjusted by increasing the concentration of CaCl<sub>2</sub> in water from 0M to 5M, Table II. Mao *et al.*<sup>8</sup> reported a liquid gradient refractive index (L-GRIN) lens, Fig. 1(a). The lens is formed by diffusion of CaCl<sub>2</sub> from a core stream with a concentration of 3.5M to the cladding stream of de-ionized (DI)-water. The refractive index decreases gradually from  $n=1.41$  to  $n=1.33$ . The concentration profile and the corresponding refractive index profile can be controlled by the flow rate of the core stream and the two cladding streams. The dimensionless number representing the relative ratio between advection transport and molecular diffusion is the Peclet number,

$$\text{Pe} = \frac{UL_{\text{ch}}}{D}, \quad (1)$$

where  $U$  is the mean flow velocity,  $L_{\text{ch}}$  is the characteristic diffusion length, and  $D$  is molecular diffusion coefficient. A higher flow rate results in a higher Peclet number, where advective trans-

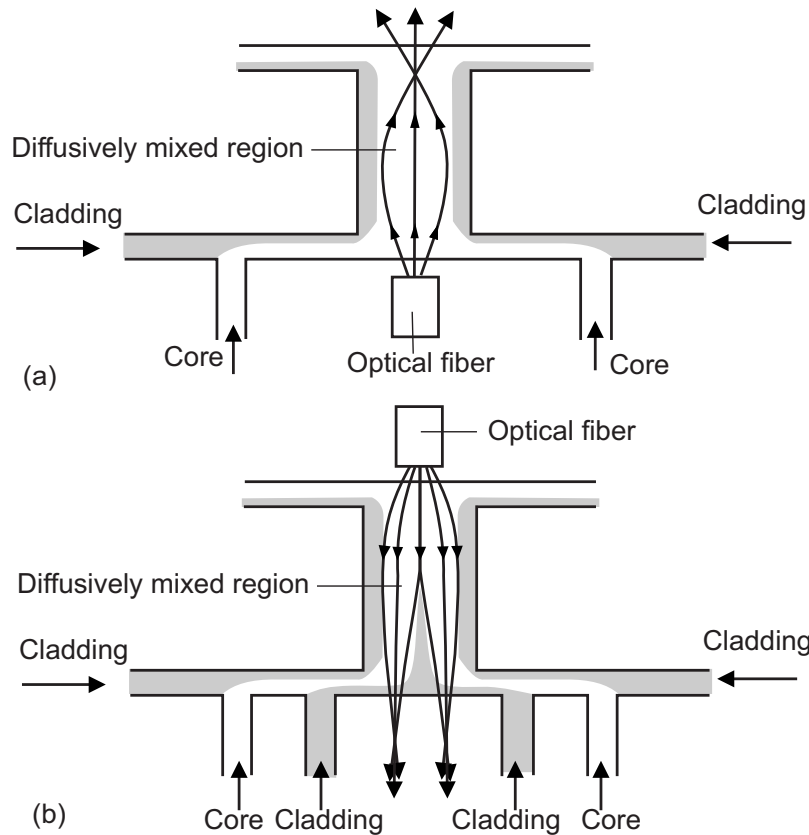

FIG. 1. Micro-optofluidic devices based on a gradient of refractive index: (a) L-GRIN lens; (b) optical splitter.

port dominates over molecular diffusion. A higher Peclet number therefore means a larger gradient of refractive index. A large gradient of refractive index allows a sharper bend of light beams resulting in a shorter focal length. The focal point cannot only be tuned along the flow direction but also in the direction perpendicular to it. By changing the flow rate ratio of the cladding streams, the concentration profile is screwed to one side allowing the light beam to be focused off the optical axis. With the diffusion coefficient of calcium chloride of  $D_{\text{CaCl}_2} = 1.15 \times 10^{-5} \text{ cm}^2/\text{s}$ ,<sup>9</sup> the Peclet number for the L-GRIN lens reported in Ref. 8 ranges from 120 to 280.

Another way to modify the optical properties of liquid is using scattering caused by suspended nanoparticles.<sup>10</sup> Compared to smaller molecules, the lower diffusion coefficient of nanoparticles would allow the liquid with modified refractive index to be contained in the stream. The scattering nature makes suspending nanoparticles rather suitable for wave guiding than lensing applications.

Besides L-GRIN lenses, a complex concentration distribution would allow designing other innovative micro-optofluidic devices. Wolfe *et al.*<sup>11</sup> utilized diffusive merging of two core streams to realize an optical splitter. Two core streams of ethylene glycol are separated by the cladding liquid with lower refractive index. At low Peclet numbers, the two core streams merge to a single stream with high refractive index. This concentration distribution of the core liquid allows splitting a single input beam into two output beams with equal intensities, Fig. 1(b). With the data from Ref. 11 (diffusion coefficient of ethylene glycol  $D = 5 \times 10^{-6} \text{ cm}^2/\text{s}$ ), the condition for good mixing and consequently good light splitting is  $Pe < 266$ , which is of the same order as required for L-GRIN lenses.

Similar to many other physical variables, refractive index is temperature dependent. Refractive index usually decreases with increasing temperature. A temperature field can induce a refractive index gradient. The same concept of designing L-GRIN lens using concentration-dependent refractive index can be used for thermal mixing of liquid streams. Since thermal diffusivity in

TABLE III. Out-of-plane micro-optofluidic lenses (Ref.: reference,  $D$ : aperture size,  $n$ : refractive index,  $f$ : focal length;  $p_{\max}$ : maximum pressure,  $V_{\max}$ : maximum voltage, pcv: planoconvex, bcv: biconvex, pcc: planoconcave, bcc: biconcave, and cvcc: convex/concave).

Ref.	Tuning concept	Lens type	$D$ (mm)	$n$	Interface	$f$ (mm)	$p_{\max}$ (kPa)	$V_{\max}, I_{\max}$
17	Pneumatic	pcv, bcv	10	1.65	l/s/a	300–500	2.5	...
18	Pneumatic	pcv	20	1.3–1.5	l/s/a	41–172	6	...
19	Pneumatic	pcv, bcv	0.4	1.35–1.6	l/s/a	1–10	55	...
20	Pneumatic	pcv	0.2	1.51–1.56	l/s/a	1–6	35	...
21	Pneumatic	pcv	0.5	1.33–1.52	l/s/a	0.6–3	10	...
22	Pneumatic	All	20	1.3–1.5	l/s/a	16–200	–2–7	...
23	Pneumatic	bcv, bcc	4	1.33	l/s/a	3.1–75.9	...	...
24	Pneumatic	All	3	1.33–1.58	l/s/a	–40–23	2	...
25	Pneumatic	pcv	0.6–1.4	1.33	l/s/a	3.8–10.6	1.3	...
26	Pneumatic	pcc, bcc	8	1.42	l/s/a	191–808	5	...
27	Pneumatic	pcv	15	1.33–1.6	l/s/a	0.25–6	...	...
28	Pneumatic	pcv	5	1.33	l/s/a	20–100	...	...
29	Pneumatic	pcv	2.5	...	l/s/a	15–57	9	...
31	Pneumatic	pcv, bcv	0.12	1.4	l/s/a	...	207	...
33	Pneumatic	pcc, cvcc	1	1.33	l/s/a	2–8	0.2	...
35	EAP	pcv	2.8	...	l/s/a	...	...	50 V
37	Electromagnetic	pcv	3	1.47	l/s/a	0.25–6	...	30 mA
38	Electrochemical	bcv	1.8	1.3	l/a	3– $\infty$	...	–1.3–1.3 V
39	Hydrogel	pcv, pcc	2	1.33	l/l	–11.7–22.8	...	...
40	Hydrogel	pcv, pcc	2	1.33	l/l	–17.4–8.0	...	...
43	Electrowetting	pcv	2.5	1.3	l/l	9–20	...	250
44	Electrowetting	pcv, pcc	1	1.33	l/a	3.8–4.4	...	100 V
45	Electrowetting	pcv	2–4	...	l/l	10–30	...	150
46	Electrowetting	pcv	4	1.38–1.55	l/l	20–500	...	50 V
47	Electrowetting	pcv	8	1.51	l/l	23– $\infty$	...	45 V
49	Electrowetting	pcv	3	1.4–1.6	l/l	12–34	...	75 V
48	Dielectrophoresis	pcv	1.76	...	l/a	1.6–2.6	...	200 V
50 and 51	Dielectrophoresis	pcv	...	1.47–1.67	l/l	0.5–0.65	...	90 V

liquids is about two orders of magnitude higher than molecular diffusion coefficient, the flow rate does not need to be extremely low to reach Peclet numbers on the order of 100. The only drawback of using temperature to modulate refractive index is the relatively small thermo-optical coefficient  $dn/dT$  of most liquids. For instance, the thermo-optical coefficient in the temperature range from 0 to 80 °C of water, ethylene glycol, and ethanol are  $-1.2 \times 10^{-4}$ ,  $-2.6 \times 10^{-4}$ , and  $-4.0 \times 10^{-4}$  K $^{-1}$ , respectively.<sup>12</sup> Seta *et al.*<sup>15</sup> used a thermal lens formed by heat induced by focus light to detect nanoparticles. Tang *et al.*<sup>12</sup> generated a temperature gradient and the corresponding refractive index gradient by coflowing streams with different temperatures.

The refractive index of liquid crystal (LC) can be modified by an applied electric field.<sup>14–16</sup> A light beam experiences a different refractive index depending on the state of the liquid crystal, which is controlled by an electric field. A concept similar to that of L-GRIN lenses can be used for LC. Under the applied electric field, liquid crystal molecules reorient and retard the propagating light beam. A LC lens can therefore be designed by the configuration of the electrodes and the corresponding electric field. For more details on variable-focusing lenses made of liquid crystals, readers may refer to the comprehensive review by Sato.<sup>14</sup>

For common operating temperature range of a digital camera between  $-30$  and  $70$  °C, the liquid used in micro-optofluidic lenses should have a low freezing point. For an aqueous solution,

TABLE IV. In-plane micro-optofluidic lenses (Ref.: reference,  $D$ : aperture size,  $n$ : refractive index,  $f$ : focal length; Re: Reynolds number, Pe: Peclet number, pcv: planoconvex, bcv: biconvex, pcc: planoconcave, bcc: biconcave, and cvcc: convex/concave).

Ref.	Lens type	$D$ (mm)	$n$	Interface	$f$ (mm)	Re	Pe
34	pcv	0.155	1.33	l/a	2–13	$3.6 \times 10^{-3}$	...
54	bcv, pcv, cvcc	0.334	1.33–1.60	l/l	5–12	0.166	5555
55	bcv, pcv, cvcc	0.525	1.46	l/l	0.26–0.33	0.385	14 492
56	bcv	...	1.638	l/l	...	12	32 000
7	bcv	0.35	1.62	l/l	1.5–3	0.5	3703
58	pcv	0.155	1.445	l/l	0.2– $\infty$	2.5	18 700
8	L-GRIN	0.155	1.41	l/l	0.2	0.1	280

the low freezing point can be achieved by using a highly concentrated salt solution. For lenses based on nonthermal concepts, the thermo-optical coefficient  $dn/dT$  should be kept at a minimum value. The key parameters of out-of-plane and in-plane amicrooptofluidic lenses are summarized in Table III and IV), respectively.

### III. TUNABILITY WITH LENS SHAPE

#### A. Pneumatic tuning

##### 1. Out-of-plane designs

Most out-of-plane micro-optofluidic lenses are designed as a circular chamber covered by a flexible membrane. The membrane deforms when a pressure is applied to the lens liquid. The pressure can adjust the radius of curvature of the spherical membrane and consequently the focal length, Fig. 2.

The design of pneumatically tunable out-of-plane optofluidic lenses was inspired by human's eye. Ahn and Kim<sup>17</sup> reported a lens made with conventional micromachining technology based on silicon and glass. The 40- $\mu\text{m}$ -thick glass membrane is tuned by pressure delivered by a pump. Index-matching liquid ( $n=1.65$ ) was used as the working fluid. Due to the high Young modulus of the lens material, a small deformation (up to 50  $\mu\text{m}$  for a 10 mm lens) leads to a relatively large focal length from 30 to 60 cm. The size of the lens and the corresponding aperture size and focal length can be reduced using a softer material such as PDMS,<sup>18</sup> Fig. 2(a). Werber and Zappe<sup>19</sup> replaced the glass membrane by a 50- $\mu\text{m}$ -thick PDMS layer. The spin-coated PDMS can reach a smoothness of about 8 nm. The lens chamber was etched in silicon with deep reactive ion etching (DRIE) and sealed by anodic bonding to a Pyrex glass wafer. Chronis *et al.*<sup>20</sup> reported a lens with 200- $\mu\text{m}$ -diameter and 40- $\mu\text{m}$ -thick membrane. The flexible PDMS allows reducing the maximum radius of curvature of the lens to about 5 mm and a focal length from 1 to 6 mm (Table III).

The planoconvex design of Chronis *et al.*<sup>20</sup> was improved by a biconvex design by Jeong *et al.*,<sup>21</sup> Fig. 2(b). An even shorter focal length from 0.6 to 3 mm was obtained. Zhang *et al.*<sup>22</sup> used two lens chambers to vary the two lens curvatures independently, Fig. 2(c). The lens chambers are formed by sandwiching a glass slide between two PDMS pieces. The PDMS membrane is 60  $\mu\text{m}$  thick. Agarwal *et al.*<sup>23</sup> reported the same design implemented with three silicon layers. The lens chambers were etched using DRIE. A 60- $\mu\text{m}$ -thick PDMS membrane was spin-coated and transferred to the silicon surface to work as the lens membrane. Pang *et al.*<sup>24</sup> realized the biconvex design in multiple layers of PDMS. This design allows the formation of three lens chambers with three independent controllable pressures. Adjusting these three pressures allows forming different lens shapes.

Chen *et al.*<sup>25</sup> used a similar approach as reported by Jeong *et al.*<sup>21</sup> to form a spherical surface in PDMS. The technique is based on the droplet formation of a liquid polymers such as photore-sists on a planar surface. While Jeong *et al.*<sup>21</sup> used the molded concave PDMS surface for the lens,



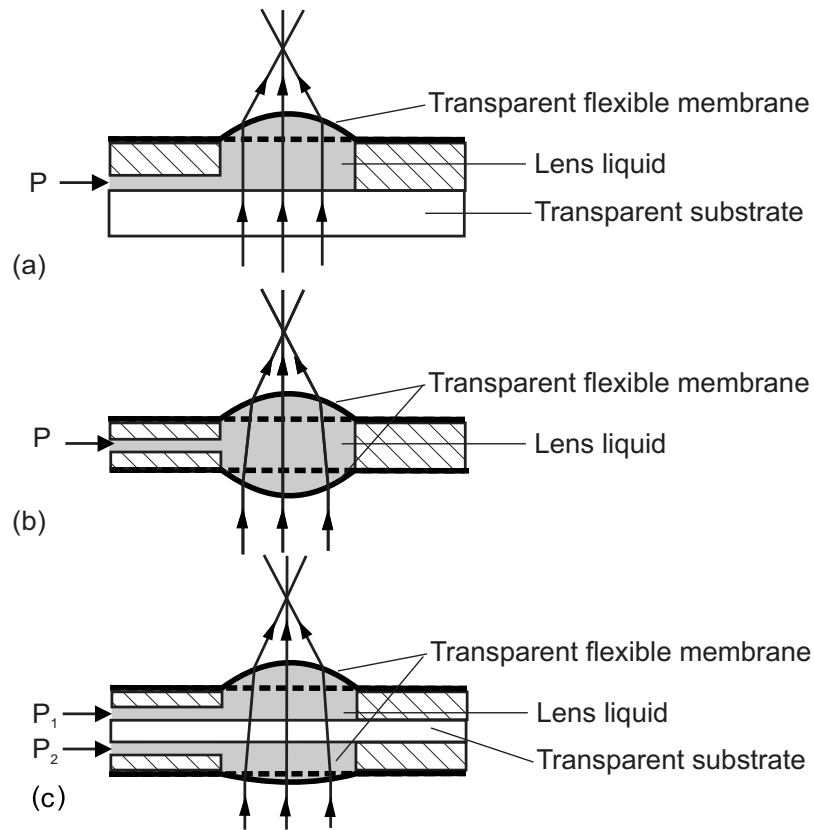

FIG. 2. Pneumatically tunable out-of-plane liquid lenses.

Chen *et al.*<sup>25</sup> used the concave PDMS surface as a mold to make a convex PDMS lens. The planoconvex PDMS is used as the membrane for the tunable liquid lens to form a complex liquid/solid lens system. Feng and Chou<sup>26</sup> used a biconvex and a convex-concave PDMS lens as walls of the lens chamber to form a complex PDMS/liquid/PDMS lens system (Fig. 3).

Most of the above mentioned designs use external pressure supply to tune the lens shape. Because of this reason, fluidic interconnects and tubing are required. A more compact design can be achieved if the liquid is contained inside the lens chamber and the pressure is transferred indirectly from an actuator. Ren *et al.*<sup>27</sup> sealed the liquid in the lens chamber and applied pressure through a squeezing string driven by a servo motor. Another version used a mechanical lever to transfer the pressure to the lens chamber.<sup>28</sup>

Another variation of pressure tunable lens is the double-focus lens reported by Yu *et al.*<sup>29,30</sup> The lens membrane was made with different thicknesses leading to the different radii of curvatures. A parallel light beam will be focused at a spot and a ring at different focal lengths. Multi-focus lens can be used for applications that require optical detection and manipulation at different positions.

## 2. In-plane designs

The above lens concept with a deformed PDMS membrane can be implemented for in-plane configuration. Hsiung *et al.*<sup>31</sup> formed a 40  $\mu\text{m}$  membrane in the same molding process of the microfluidic network. The lens surfaces measure  $120 \times 100$  and  $400 \times 100 \mu\text{m}^2$ , respectively. With this small membrane size, the deformation is not large enough to form short focal length, Fig. 3(a).

In-plane micro-optofluidic lenses utilize the curvature formed by the interface between two immiscible liquids or between liquid and air. Balancing the applied pressure with the interfacial



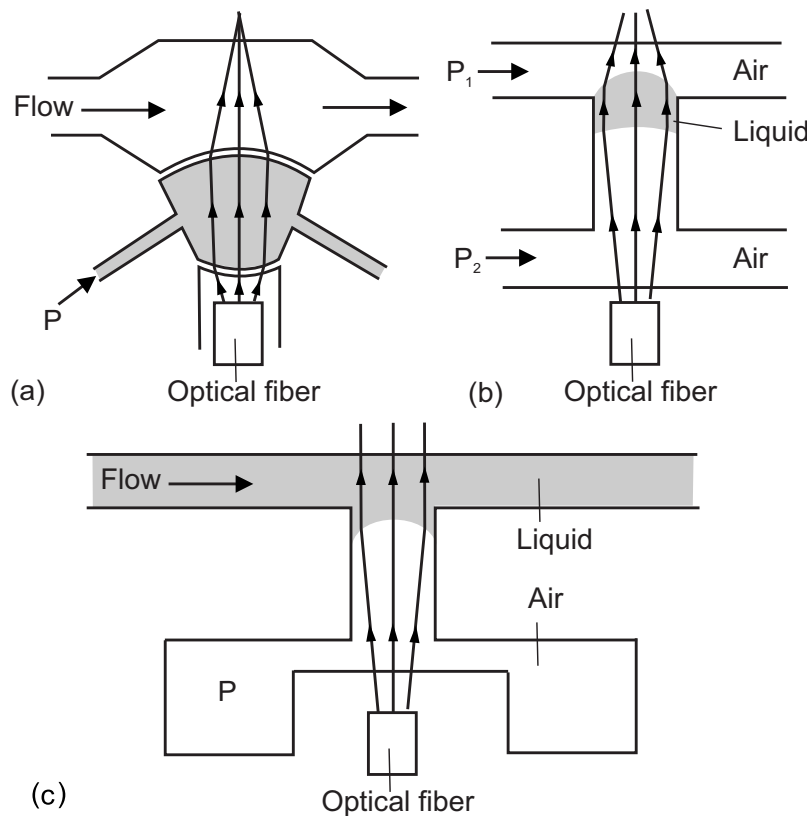

FIG. 3. Pneumatically tunable in-plane liquid lenses: (a) biconvex lens with flexible membrane; (b) convex/concave lens; (c) planoconcave lens.

tension can adjust the radius of curvature of the interface. Lien *et al.*<sup>32</sup> used this concept to form a smooth liquid PDMS surface. After curing, PDMS forms a solid liquid. At the place of lens formation, the PDMS surface was treated with silane to stop the capillary flow of the liquid PDMS, Fig. 3(b). Dong and Jiang<sup>33</sup> used liquid/air interface in a microchannel to form an in-plane lens. The microchannel network was formed with photolithography of a photosensitive polymer sandwiched between two glass slides. The channel surface was treated with octadecyltrichlorosilane. Liquid slugs are formed at a T-junction and pinched at the lens channel. The relatively small radius of curvature allows short focal length ranging from 2 to 9 mm. The short focal length makes the on-chip use of the lens possible. Since the pneumatic pressure does not need to deform a flexible membrane, only a low actuation pressure of less than 200 Pa is needed for tuning the lens. Shi *et al.*<sup>34</sup> formed a curved liquid/air interface with a simpler concept, Fig. 3(c). Due to the low static pressure required for tuning, the pressure is adjusted with the flow rate flowing through a microchannel. This pressure works against the interfacial tension and the pressure of the trapped air in a chamber. The optical system consists of the micro-optofluidic lens and a PDMS lens. To minimize scattering loss due to roughness of the PDMS sidewall, the silicon mold was treated with a layer of perfluorooctyltrichlorosilane.

## B. Electric tuning

Electric actuation can be used for modulating the pressure in the lens chamber. Common concepts such as piezoelectric, electromagnetic, and electrochemical actuations can be used for this purpose. Choi and Lee *et al.*<sup>35,36</sup> used electroactive polymer (EAP) for generating the actuation pressure. EAP can induce high strains, Fig. 4(a). The actuation requires a voltage up to 50 V. No details about the used liquid and the focal distance were reported. Lee and Lee<sup>37</sup> used embed-

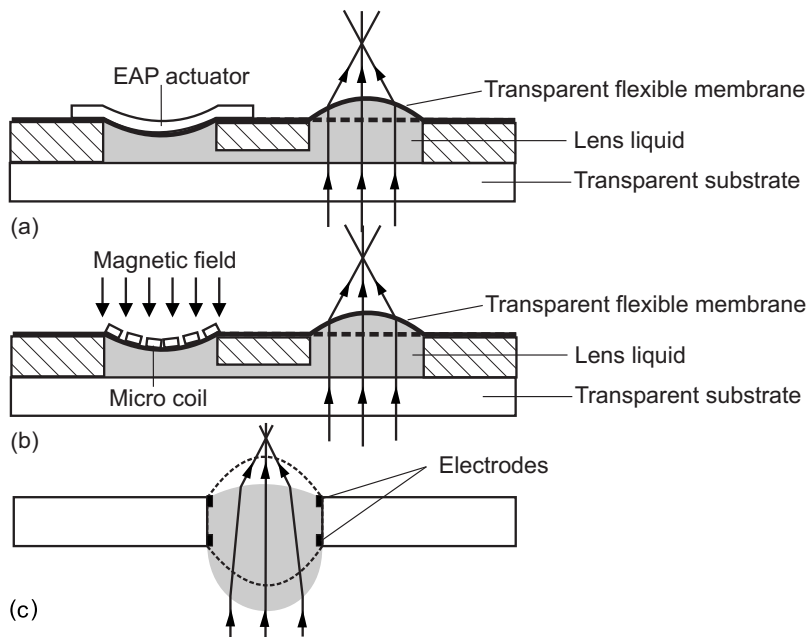

FIG. 4. Electrically tunable liquid lenses: (a) electroactive polymer actuator; (b) electromagnetic actuator; (c) electrochemical actuator.

ded microcoil made of gold to generate the actuation pressure. The gold layer was deposited before spin coating the  $11\text{-}\mu\text{m}$ -thick PDMS membrane for the lens, Fig. 4(b). A maximum deflection of  $51.4\ \mu\text{m}$  can be achieved with 30 mA driving current. No details on the focal distance were reported for this lens.

Electric field can be used to control the surface tension that in turn tunes the radius of curvature. López *et al.*<sup>38</sup> utilized the reduction-oxidation process of a water soluble ferrocenyl surfactant to control the surface tension. The lens is made of the solution of the surfactant filled in a hole with a radius of 0.89 mm, Fig. 4(c) drilled in Teflon. Electrodes are built on both side of the substrate. The surface tension increases with oxidation and decreases with reduction. Thus, when a voltage is applied on the electrodes, the radius of curvature on one side of the droplet decreases, while the radius of curvature on the other side increases.

### C. Tuning with stimuli responsive hydrogels

Stimuli responsive hydrogel is another type of actuator that can be used to induce a pressure for deforming the liquid lens. Dong *et al.*<sup>39</sup> used hydrogels sensitive to temperature and pH values to control the lens shape. The liquid lens is shaped by the interface between water and oil. Water is contained in a ring made of hydrogels and works as the lens liquid, Fig. 5. The temperature sensitive hydrogel expands at low temperature and contracts at high temperature. The temperature

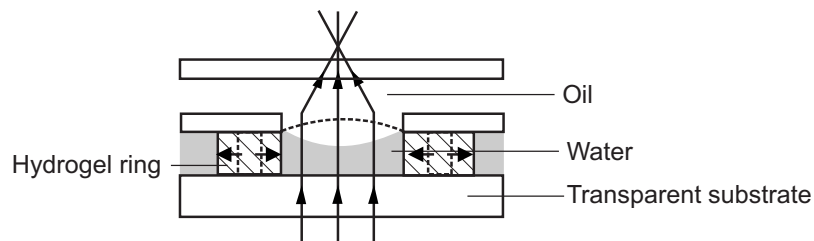

FIG. 5. Liquid lenses tunable with stimuli responsive hydrogel.

range is from 20 to 50 °C with a transition temperature of about 32 °C. The pH sensitive hydrogel expands in basic solutions and contracts in acid solutions. The pH range is from 2 to 12. Since this actuation concept relies on thermal diffusion and molecular diffusion, the response time is relatively low (20–30 s) compared to other actuation concepts. Depending on the structure of the hydrogel, the response time can be reduced to 2–3 s. Zeng and Jiang<sup>40</sup> mixed water soluble gold nanoparticles with a thermoresponsive reversible N-isopropylacrylamide hydrogel to make an IR light responsive hydrogel. The nanoparticles have strong optical absorption characteristics of IR light making the lens tunable with IR radiation.

#### D. Tuning with electrowetting

A fast and effective way to tune the lens shape is electrowetting. Electrowetting effects utilize the electrostatic force at the solid liquid interface to reduce the contact angle between an electrolyte and a solid surface. The three main electrowetting concepts are continuous electrowetting, direct electrowetting, and electrowetting on dielectric.<sup>41</sup> Continuous electrowetting occurs at the interface between two conducting liquids such as mercury and an electrolyte. Direct electrowetting is realized between an electrolyte and a solid electrode. The relationship between the contact angle  $\theta$  and the applied voltage  $V$  is described by the Young–Lippman equation,

$$\cos(\theta) = \cos(\theta_0) + \frac{\varepsilon\varepsilon_0}{2\sigma\lambda_D}V^2, \quad (2)$$

where  $\varepsilon_0$  and  $\varepsilon_r$  are the dielectric constant of vacuum and the relative dielectric constant of the electrolyte, and  $\lambda_D$  is the thickness of the electric double layer (EDL) at the liquid/solid interface. Because of the thin EDL, only a small voltage is needed for changing the contact angle of the lens. However, the direct contact causes electrolysis and gas bubbles. In electrowetting on dielectric, the electric field is applied across an insulation layer that can prevent electrolysis. The same Young–Lippman equation applies to the contact angle in the case of electrowetting on dielectric. The relative dielectric constant is that of the dielectric in use and the thickness of the dielectric replaces the thickness of the EDL in Eq. (2). Most of the liquid lenses reported in literature are based on electrowetting on dielectric.

Besides electrostatic force and interfacial tension, gravity also plays an important role for the shape of the liquid lens based on electrowetting. Matching the density of the immiscible liquids would eliminate the buoyancy force. If a difference in density of  $\Delta\rho$  cannot be avoided, the lens shape should be maintained at a scale much smaller than the capillary length,

$$\lambda = \sqrt{\frac{\sigma}{\Delta\rho g}}, \quad (3)$$

where  $g$  is the gravity acceleration.

One of the first proofs of concept for liquid lens based on direct electrowetting was reported by Gorman *et al.*<sup>42</sup> Hexadecanethiol was used as the lens liquid. The lens was positioned on a gold electrode and immersed in an electrolyte. A functional lens based on electrowetting on dielectric was reported by Berge and Peseux,<sup>43</sup> Fig. 6(a). The dielectric layer has a radially variable thickness. This design allows the liquid droplet to be centered at the optical axis and imposes a circular base for the droplet. The response time of this lens was 25 ms. Since the lens system dynamically represents a second order system, the response to a step change of the voltage is oscillatory. Increasing the viscosity of the liquid increases the damping factor of the system. Krupenkin<sup>44</sup> reported a planar electrode system. Only a small range of focal length was estimated for this lens. Liu *et al.*<sup>45</sup> reported a double-ring electrode design. The first ring electrode defines the region of the liquid lens. The second ring electrode is used for actuation.

Kuiper and Hendriks<sup>46</sup> reported a functional lens based on electrowetting. In contrast to the other designs, this lens wets the sidewall allowing the formation of a planoconcave lens, Fig. 6(b). The concept of wetting on the sidewall was further developed by Krogmann *et al.*<sup>47</sup> The electrode system was implemented with silicon technology to allow the batch fabrication of the lens.

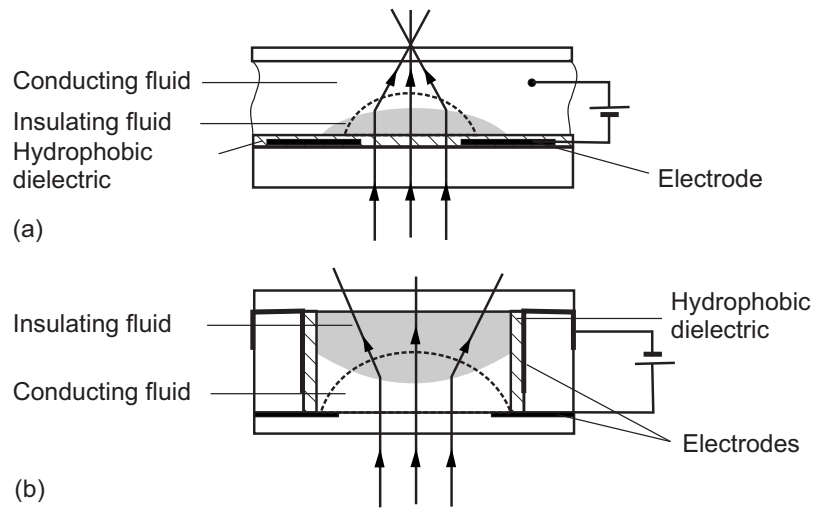

FIG. 6. Liquid lenses tunable with electrowetting: (a) planar electrode; (b) sidewall electrodes.

### E. Dielectrophoretic tuning

Dielectrophoresis is another phenomenon that can be used for tuning micro-optofluidic lenses. Dielectrophoresis does not need an electrically conducting liquid to function. A molecule of the dielectric liquid experiences a net force in a gradient of electric field. Unlike electrowetting, dielectrophoresis is a body-force phenomenon. Compared to electrowetting, dielectrophoretic tuning consumes one order of magnitude less power.<sup>48</sup> The dielectric force density can be formulated as<sup>49</sup>

$$\mathbf{f} = -\frac{\epsilon_0}{2} \nabla [(\epsilon_1 - \epsilon_2)|\mathbf{E}|^2], \quad (4)$$

where  $\epsilon_1$  and  $\epsilon_2$  are the relative dielectric constants of the surrounding fluid and the lens liquid and  $\mathbf{E}$  is the electric field strength across the liquid/liquid interface.

Cheng *et al.*<sup>48</sup> used liquid crystal as the lens liquid with high dielectric constant. The electric field gradient was generated by a circular interdigitated electrode system. Teflon works as the hydrophobic insulation layer. Another version of this lens used a dielectric liquid as the surrounding fluid so that the lens can be packaged inside an enclosure. Ren *et al.*<sup>50,51</sup> used dielectric fluids with mismatching refractive indices (1.47 and 1.67) to form the lens between two parallel transparent indium tin oxide electrodes, Fig. 7. A relatively high voltage up to 90 V is needed to control the shape of the lens in a gap of 110  $\mu\text{m}$  between the two electrodes.

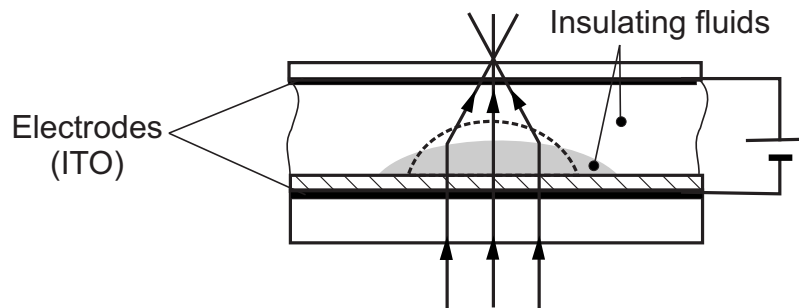

FIG. 7. Liquid lenses tunable with dielectrophoresis.

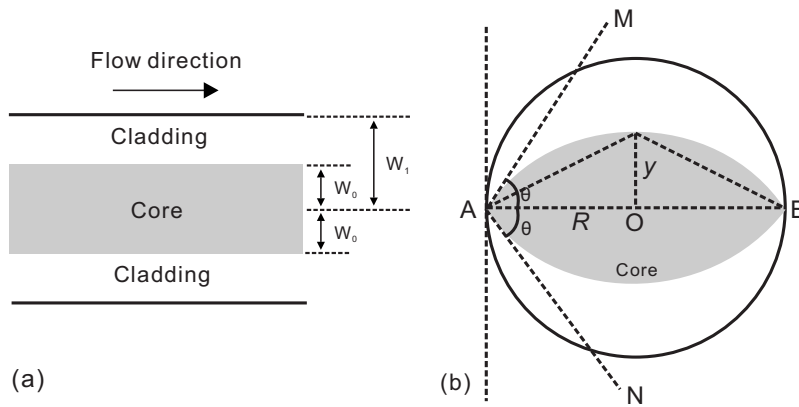

FIG. 8. Schematic of hydrodynamic focusing in microfluidic channels of different geometries: (a) straight channel; (b) circularly bounded chamber.

### F. Hydrodynamic tuning

A curved liquid/liquid interface can be formed and controlled by hydrodynamic force. A liquid-core liquid-cladding micro-optofluidic system represents a fluidic configuration known as hydrodynamic focusing. Considering a symmetric system, the relationship between the flow rate ratio ( $Q_{\text{core}}/Q_{\text{cladding}}$ ) and widths of the core and cladding streams can be described by the hydrodynamic focusing theory,<sup>52</sup>

$$\frac{\mu_{\text{core}}}{\mu_{\text{cladding}}} \frac{Q_{\text{core}}}{Q_{\text{cladding}}} = \frac{2W_0}{W_1 - W_0}, \quad (5)$$

where  $\mu$  is the viscosity of the fluid and  $Q$  represents the flow rate. The widths of the streams are depicted in Fig. 7(a).

Instead of using a straight microchannel, hydrodynamic focusing can generate a curved interface in a circular chamber, Fig. 8. The streamlines spread from a source point A and flow back to a sink point B in a circularly bounded domain. At source point A, the flow rate ratio as well as the viscosity ratio determines the opening angles of the core stream and the cladding stream. Consequently, the curvature of the interface between the core stream and the cladding stream can be determined since each streamline path has its unique arc-shape in a circular chamber. Equation (5) can be written in the angular form as

$$\frac{\mu_{\text{core}}}{\mu_{\text{cladding}}} \frac{Q_{\text{core}}}{Q_{\text{cladding}}} = \frac{2\theta}{\pi/2 - \theta}, \quad (6)$$

where  $2\theta$  and the  $\pi/2 - \theta$  are the opening angles of the core stream and the cladding stream at source point A, respectively. Using Eq. (6), the relationship between flow rate ratio and the radius of the interface can be analytically described as

$$\frac{Q_{\text{core}}}{Q_{\text{cladding}}} = \frac{\mu_{\text{cladding}}}{\mu_{\text{core}}} \frac{2 \arctan(r/R - \sqrt{r^2 - R^2}/R)}{\pi/4 - \arctan(r/R - \sqrt{r^2 - R^2}/R)}. \quad (7)$$

If the core liquid and cladding liquid have the same viscosity, Eq. (7) reduces to the same form as derived by the model of dipole flow bounded in a circular domain.<sup>53</sup> With the known radius of curvature, the relationship between the flow rate ratio and the focal length can be derived as

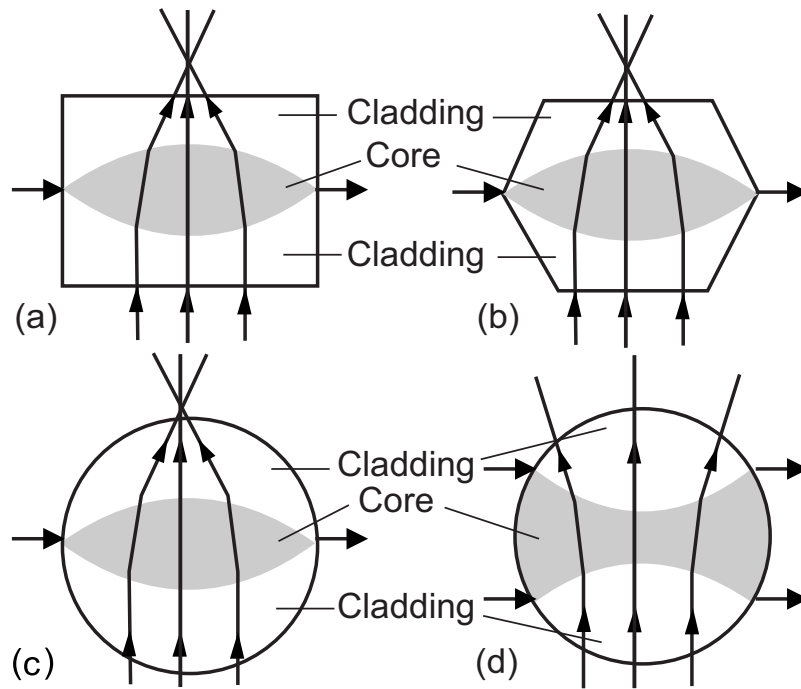

FIG. 9. In-plane micro-optofluidic lens with hydrodynamic tuning: [(a) and (b)] rectangular chambers; (c) circularly bounded chamber; (d) biconcave lens with two pairs of inlets.

$$\frac{Q_{\text{core}}}{Q_{\text{cladding}}} = \frac{\mu_{\text{cladding}}}{\mu_{\text{core}}} \frac{2 \arctan\left(\frac{2(n-1)f - \sqrt{4(n-1)^2f^2 - R^2}}{R}\right)}{\pi/4 - \arctan\left(\frac{2(n-1)f - \sqrt{4(n-1)^2f^2 - R^2}}{R}\right)}. \quad (8)$$

Tang *et al.*<sup>54</sup> reported the first liquid-core liquid-cladding lens based on hydrodynamic focusing, Fig. 9(a). The lens was formed in an expanded microchannel with parallel sidewalls. Because of this design, the liquid/liquid interface takes up the shape of the channel at high core flow rate. Similar designs of the same concept were later reported by Seow *et al.*<sup>55</sup> [Fig. 9(b)] and Rosenauer and Vellekoop.<sup>56</sup> Song *et al.*<sup>7</sup> used the a circular lens chamber as described above to make a liquid/liquid interface with a perfect arc-shape, Fig. 9(c).

A lens chamber with a single inlet and single exit can form biconvex, planoconvex, and concave/convex lenses. However, it is not possible to form biconcave or planoconcave lenses with this design. Song *et al.* proposed a chamber design with two inlets and two exits. This chamber design allows the formation of biconcave and planoconcave lenses, Fig. 9(d). These lens shapes allow focusing light using liquids with refractive index lower than that of cured PDMS, the common material for many reported micro-optofluidic lenses.

Equation (8) shows that the focal length is determined by the flow rate ratio and the size of the lens chamber. To form lenses with radius of curvature smaller than the chamber radius, Song *et al.*<sup>57</sup> placed the inlet and exit asymmetrically. This arrangement leads to even shorter focal length, which is often needed for on-chip applications. Another solution for designing a lens with short focal length was reported by Mao *et al.*<sup>58</sup> The curved liquid/liquid interface is formed by centrifugal force.

#### IV. CONCLUSIONS

This paper reviews the state of the art of micro-optofluidic lenses. The development of these lenses attracts attention from both microfluidics and micro-optofluidics research communities due

to their apparent advantages in miniaturization and tunability. All the lenses reported in literature can be categorized into out-of-plane and in-plane families. Tunable out-of-plane lenses are suitable for replacing conventional lens system in imaging devices such as digital camera, cell phone, surgical camera, and possibly intraocular lens for restoration of human vision. In-plane lenses can be implemented in the same system with conventional microfluidic devices. Therefore, in-plane lenses have a huge potential for on-chip optical detection and manipulation. The two basic strategies of tunability are controlling the refractive index of the lens liquid and controlling the lens shape. Changing the lens liquid and consequently its refractive index would require flow control components such as microvalve and micropump. Since the refractive index of many liquids is dependent on temperature, electric, and magnetic fields, these physical fields can be used for modulating the refractive index without changing the liquid. The lens shape can be controlled by a number of actuation concepts ranging from the simple pneumatic actuation to the more complex electrowetting actuation. Hydrodynamic focusing has been proven as a simple concept for forming in-plane micro-optofluidic lenses. With careful design of the lens chamber and positions of inlets and outlets, it is possible to implement a complex lens system with both concave and convex surfaces.

Liquid is an advantage but also the main drawback of micro-optofluidic lenses. Even in microscale, liquids are prone to shape instability and evaporation. For applications that require a wide range of operating temperature, designing a liquid lens is a challenge because almost all physical properties of a liquid are temperature dependent. For micro-optofluidic lenses that require a continuous supply of liquid streams, flow control and the large amount of liquid are the main hurdles toward practical applications of these innovative devices.

- <sup>1</sup>D. Psaltis, S. R. Quake, and C. Yang, *Nature (London)* **442**, 381 (2006).
- <sup>2</sup>C. Monat, P. Domachuk, and B. J. Eggleton, *Nat. Photonics* **1**, 106 (2007).
- <sup>3</sup>C. Monat, P. Domachuk, C. Grillet, M. Collins, B. J. Eggleton, M. Cronin-Golomb, S. Mutzenich, T. Mahmud, G. Rosengarten, and A. Mitchell, *Microfluid. Nanofluid.* **4**, 81 (2008).
- <sup>4</sup>H. C. Hunt and J. S. Wilkinson, *Microfluid. Nanofluid.* **4**, 53 (2008).
- <sup>5</sup>D. Erickson, X. Heng, Z. Y. Li, T. Rockwood, T. Emery, Z. Y. Zhang, A. Sherer, C. H. Yang, and D. Psaltis, *Proc. SPIE* **5908**, 59080S (2005).
- <sup>6</sup>U. Levy and R. Shamaï, *Microfluid. Nanofluid.* **4**, 97 (2008).
- <sup>7</sup>C. L. Song, N. T. Nguyen, A. K. Asundi, and C. L. N. Low, *Opt. Lett.* **34**, 3622 (2009).
- <sup>8</sup>X. L. Mao, S. C. S. Lin, M. I. Lapsley, J. J. Shi, B. K. Juluri, and T. J. Huang, *Lab Chip* **9**, 2050 (2009).
- <sup>9</sup>R. A. Robinson and C. L. Chia, *J. Am. Chem. Soc.* **74**, 2776 (1952).
- <sup>10</sup>R. S. Conroy, B. T. Mayers, D. V. Vezenov, D. B. Wolfe, M. G. Prentiss, and G. M. Whitesides, *Appl. Opt.* **44**, 7853 (2005).
- <sup>11</sup>D. B. Wolfe, D. V. Vezenov, B. T. Mayers, and G. M. Whitesides, *Appl. Phys. Lett.* **87**, 181105 (2005).
- <sup>12</sup>S. K. Y. Tang, B. T. Mayers, D. V. Vezenov, and G. M. Whitesides, *Appl. Phys. Lett.* **88**, 061112 (2006).
- <sup>13</sup>N. Seta, K. Mawatari, and T. Kitamori, *Anal. Sci.* **25**, 275 (2009).
- <sup>14</sup>S. Sato, *Opt. Rev.* **6**, 471 (1999).
- <sup>15</sup>L. G. Commander, S. E. Day, and D. R. Selviah, *Opt. Commun.* **177**, 157 (2000).
- <sup>16</sup>P. J. Smith, C. M. Taylor, E. M. McCabe, D. R. Selviah, S. E. Day, and L. G. Commander, *Rev. Sci. Instrum.* **72**, 3132 (2001).
- <sup>17</sup>S. H. Ahn and Y. K. Kim, *Sens. Actuators, A* **78**, 48 (1999).
- <sup>18</sup>D. Y. Zhang, V. Lien, Y. Berdichevsky, J. H. Choi, and Y. H. Lo, *Appl. Phys. Lett.* **82**, 3171 (2003).
- <sup>19</sup>A. Werber and H. Zappe, *Appl. Opt.* **44**, 3238 (2005).
- <sup>20</sup>N. Chronis, G. L. Liu, K. H. Jeong, and L. P. Lee, *Opt. Express* **11**, 2370 (2003).
- <sup>21</sup>K. H. Jeong, G. L. Liu, N. Chronis, and L. P. Lee, *Opt. Express* **12**, 2494 (2004).
- <sup>22</sup>D. Y. Zhang, N. Justis, and Y. H. Lo, *Appl. Phys. Lett.* **84**, 4194 (2004).
- <sup>23</sup>M. Agarwal, R. A. Gunasekaran, P. Coane, and K. Varahramyan, *J. Micromech. Microeng.* **14**, 1665 (2004).
- <sup>24</sup>L. Pang, U. Levy, K. Campbell, A. Groisman, and Y. Fainman, *Opt. Express* **13**, 9003 (2005).
- <sup>25</sup>J. Chen, W. S. Wang, J. Fang, and K. Varahramyan, *J. Micromech. Microeng.* **14**, 675 (2004).
- <sup>26</sup>G. H. Feng and Y. C. Chou, *Sens. Actuators, A* **156**, 342 (2009).
- <sup>27</sup>H. W. Ren, D. Fox, P. A. Anderson, B. Wu, and S. T. Wu, *Opt. Express* **14**, 8031 (2006).
- <sup>28</sup>H. W. Ren and S. T. Wu, *Opt. Express* **15**, 5931 (2007).
- <sup>29</sup>H. B. Yu, G. Y. Zhou, F. S. Chau, F. W. Lee, and S. H. Wang, *J. Micromech. Microeng.* **18**, 105017 (2008).
- <sup>30</sup>H. B. Yu, G. Y. Zhou, F. S. Chau, F. W. Lee, S. H. Wang, and H. M. Leung, *Opt. Express* **17**, 4782 (2009).
- <sup>31</sup>S. K. Hsiung, C. H. Lee, and G. B. Lee, *Electrophoresis* **29**, 1866 (2008).
- <sup>32</sup>V. Lien, Y. Berdichevsky, and Y. H. Lo, *Appl. Phys. Lett.* **83**, 5563 (2003).
- <sup>33</sup>L. Dong and H. R. Jiang, *J. Microelectromech. Syst.* **17**, 381 (2008).
- <sup>34</sup>J. J. Shi, Z. Stratton, S. C. S. Lin, H. Huang, and T. J. Huang, "Tunable optofluidic microlens through active pressure control of an air-liquid interface," *Microfluid. Nanofluid.* Vol. 9, Number 2-3, August 2010, pp. 313–318.
- <sup>35</sup>S. T. Choi, J. Y. Lee, J. O. Kwon, S. W. Lee, and W. B. Kim, *Proc. SPIE* **7208**, 7208P (2009).



- <sup>36</sup>J. Y. Lee, S. T. Choi, S. W. Lee, and W. B. Kim, *Proc. SPIE* **7426**, 742603 (2009).
- <sup>37</sup>S. W. Lee and S. S. Lee, *Appl. Phys. Lett.* **90**, 121129 (2007).
- <sup>38</sup>C. A. López, C.-C. Lee, and A. H. Hirs, *Appl. Phys. Lett.* **87**, 134102 (2005).
- <sup>39</sup>L. Dong, A. K. Agarwal, D. J. Beebe, and H. R. Jiang, *Nature (London)* **442**, 551 (2006).
- <sup>40</sup>X. F. Zeng and H. R. Jiang, *Appl. Phys. Lett.* **93**, 151101 (2008).
- <sup>41</sup>N. T. Nguyen and S. T. Wereley, *Fundamentals and Applications of Microfluidics* (Artech House, Boston, 2006).
- <sup>42</sup>C. B. Gorman, H. A. Biebuyck, and G. M. Whitesides, *Langmuir* **11**, 2242 (1995).
- <sup>43</sup>B. Berge and J. Peseux, *Eur. Phys. J. E* **3**, 159 (2000).
- <sup>44</sup>T. Krupenkin, S. Yang, and P. Mach, *Appl. Phys. Lett.* **82**, 316 (2003).
- <sup>45</sup>C. X. Liu, J. W. Park, and J. W. Choi, *J. Micromech. Microeng.* **18**, 035023 (2008).
- <sup>46</sup>S. Kuiper and B. H. W. Hendriks, *Appl. Phys. Lett.* **85**, 1128 (2004).
- <sup>47</sup>F. Krogmann, W. Mönch, and H. Zappe, *J. Opt. A, Pure Appl. Opt.* **8**, S330 (2006).
- <sup>48</sup>C. C. Cheng, C. A. Chang, and H. A. Yeh, *Opt. Express* **14**, 4101 (2006).
- <sup>49</sup>C. C. Cheng and H. A. Yeh, *Opt. Express* **15**, 7140 (2007).
- <sup>50</sup>H. W. Ren, H. Q. Xianyu, S. Xu, and S. T. Wu, *Opt. Express* **16**, 14954 (2008).
- <sup>51</sup>H. W. Ren and S. T. Wu, *Opt. Express* **16**, 2646 (2008).
- <sup>52</sup>N. T. Nguyen, T. F. Kong, J. H. Goh, and C. L. N. Low, *J. Micromech. Microeng.* **17**, 2169 (2007).
- <sup>53</sup>C. Song, N. T. Nguyen, S. H. Tan, and A. K. Asundi, *Lab Chip* **9**, 1178 (2009).
- <sup>54</sup>S. K. Y. Tang, C. A. Stan, and G. M. Whitesides, *Lab Chip* **8**, 395 (2008).
- <sup>55</sup>Y. C. Seow, A. Q. Liu, L. K. Chin, X. C. Li, H. J. Huang, T. H. Cheng, and X. Q. Zhou, *Appl. Phys. Lett.* **93**, 084101 (2008).
- <sup>56</sup>M. Rosenauer and M. J. Vellekoop, *Lab Chip* **9**, 1040 (2009).
- <sup>57</sup>C. L. Song and N. T. Nguyen S. H., Tan, A. Asundi, *J. Micromech. Microeng.* **19**, 085012 (2009).
- <sup>58</sup>X. L. Mao, J. R. Waldeisen, B. K. Juluri, and T. J. Huang, *Lab Chip* **7**, 1303 (2007).