

Micro-systems in biomedical applications

Paolo Dario, Maria Chiara Carrozza, Antonella Benvenuto and Arianna Menciassi

Scuola Superiore Sant'Anna-MiTech Lab via Carducci, 40 I-56127, Pisa, Italy

E-mail: dario@mail-arts.sssup.it, chiara@mail-arts.sssup.it, anto@mail-arts.sssup.it and arianna@mail-arts.sssup.it

Received 14 December 1999

Abstract. In this paper we analyse the main characteristics of some micro-devices which have been developed recently for biomedical applications. Among the many biomedical micro-systems proposed in the literature or already on the market, we have selected a few which, in our opinion, represent particularly well the technical problems to be solved, the research topics to be addressed and the opportunities offered by micro-system technology (MST) in the biomedical field. For this review we have identified four important areas of application of micro-systems in medicine and biology: (1) diagnostics; (2) drug delivery; (3) neural prosthetics and tissue engineering; and (4) minimally invasive surgery. We conclude that MST has the potential to play a major role in the development of new medical instrumentation and to have a considerable industrial impact in this field.

(Some figures in this article are in colour only in the electronic version; see www.iop.org)

1. Introduction

Medicine and biology are among the most promising, but at the same time most challenging, fields of application for micromechanics and micro-system technologies (MSTs).

Historically, the field of biomedical instrumentation has been always very important for clinical application, for research and for industry, but in the last decade the importance of biomedical instrumentation has grown at a rate even faster than in previous years. This acceleration was due, primarily, to the increasing demand for 'high-quality' medical care in highly-developed countries, and was enabled by the advent of new technologies. 'High quality' means, among other things, prevention rather than just care; accuracy and repeatability of intervention; and the lowest possible intrusion into the patient's body. An additional, very important requirement, is that high quality should be achieved at a cost acceptable for the health-care system. In general, these objectives are difficult to achieve simultaneously.

MST and micromechatronics [1] have the potential to provide technical solutions which take into account all the above objectives. In fact, MST allows for device miniaturization and, at the same time, for better performance, lower cost and higher reliability. On the other hand, material compatibility, electric hazard, energy supply, heat dissipation and device stability are among the very demanding problems that the biological environment poses and that must be solved before MST can be systematically applied to this field.

In the recent past the number of MST-based devices proposed for medical applications has become so large that a single paper cannot provide an exhaustive review of the

field. In a previous paper we presented an analysis of MST and micromechatronic devices for biomedical applications [1]. At that time the criteria we adopted for classification were based on a 'traditional' biomedical approach, that is the type/time of interaction of the biomedical micro-device with the human body. The recent technological progresses of MST and the increasing interest of the medical community for MST suggests a different classification of biomedical micro-devices, based on the estimate of the time required to develop a biomedical micro-device for clinical use, versus the *complexity* of such development. In fact, the time for development may depend not only on the technical complexity of the device, but also on the intensity of 'external' driving factors [2]. Examples of these driving factors (sometimes difficult to quantify and to predict) are the type and width of the market; the industrial interest for such market; and the strength of the need for a specific technological solution perceived by the medical community, by the health-care system, and by the social and cultural environment. Furthermore, the complexity of the micro-device encompasses technological and systems aspects (for example, micro-fabrication, sensing, actuation, control, energy supply), and is aggravated or alleviated by the type and duration of the interaction with the biological environment as well as by the requirements of the specific application.

An example of classification of biomedical micro-systems based on the approach described above, and covering a period of time of five years between the years 2000 and 2005, is illustrated in figure 1. As in a 'roadmap' guiding future development in the field, the required technologies

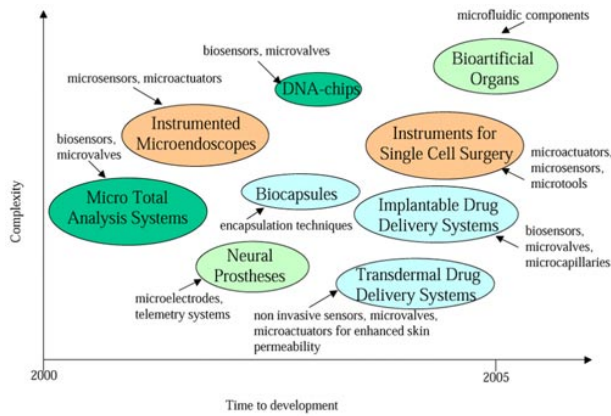

Figure 1. Classification of biomedical micro-systems.

and components are listed in the figure with reference to each class of device.

The micro-systems included in the classification belong to four important areas of application of MST in medicine and biology: (1) diagnostics; (2) drug delivery; (3) neural prosthetics and tissue engineering; and (4) minimally invasive surgery (MIS). These applications represent particularly well the technical problems to be solved, the research topics to be addressed and the opportunities offered by MST in the biomedical field. Each class of biomedical micro-devices has been ranked by the authors and represented in the complexity against time-to-development plane in a qualitative way. This representation is based on data presented in the ‘Market analysis for microsystems’ prepared by NEXUS [3], on similar data proposed by Hitchings and Wilkinson [2], and on the authors’ understanding and evaluation of these data and of the factors outlined above. More specifically, the methodology followed in [3] involved: (a) extrapolating statistical data for existing products; (b) establishing potential market share estimate for new products based on available data for existing applications; (c) making assumptions about the potential economic impact of trends in technology and society; and (d) obtaining expert opinions on products, technologies and potential applications. The study presented in [2] consisted of a retrospective analysis of product development and volume manufacturing for a selected number of successful biomedical products. The authors have extrapolated and adapted the data and trends presented in [2, 3] for some classes of MST-based devices that they believe will be particularly important for research, for clinical application and for industrial exploitation in the next five years. Referring to figure 1, we have considered: two biomedical micro-devices for application in diagnostics—the micro total analysis system and the DNA-chip; three for application in therapy—transdermal and implantable drug delivery systems, and biocapsules; two for application in the field of tissue engineering—neural micro-prostheses and bio-artificial organs; and two classes of micro-devices for application in MIS—the active endoscope and instrumentation for single-cell surgery.

In the following sections we shall describe in detail the characteristics of each different class of micro-devices and

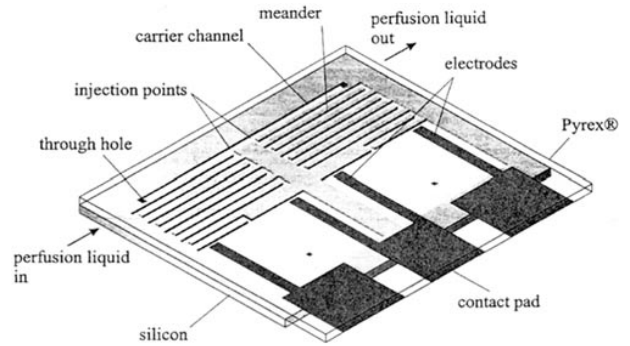

Figure 2. Schematic diagram of two micromachined pumps and dosing systems (from [11]).

outline the main considerations that led us to locate each class in a specific position of the complexity versus time-to-development plane.

2. Diagnostic systems

Current diagnostic systems for blood—or other body fluids—analysis could be improved by improving sample preparation and assay. The development of miniaturized and integrated instruments for analysis is an attractive way of improving current instrumentation. However, this development requires that a number of theoretical and technological problems in such areas as microfluidics, micromachining, microchemistry and biosensing are overcome [4]. The design and fabrication of miniaturized fluidic components is a particularly interesting problem: new methods and criteria must be defined in order to take into account scaling effects [5]. For example, when the size of a fluid channel becomes smaller than 100 μm , flow is laminar and fluid mixing is a function of diffusion. Several solutions have been found which can enhance diffusion: lamination of fluids, formation of multiple plumes of fluid and reciprocating mixing. Bubbles are often found in small channels, but this problem can be turned into a positive effect if the bubbles are used to separate fluidic boluses or even act as pumps and valves [6].

Microfluidic devices based on continuous flow pose many problems, such as severe limitations on system design imposed by the continuity condition, difficulty to discharge air bubbles sticking to internal walls and large dead volumes. In order to overcome these problems, microfluidic devices based on discrete flows have been developed [7].

The surface-to-volume ratio increases as fluidic channels reduce in size, so the adsorption of analytes and reagents is enhanced in miniaturized devices. Many different miniature valves have been developed using various microfabrication technologies and driving principles, such as thermal expansion, shape memory alloys (SMAs) [8] and thermopneumatics [9].

For micropumps employing mechanical check valves for flow rectification, wear and fatigue of small and fragile parts are critical problems to overcome. The so-called ‘valve-less pumps’ perform flow rectification using special channels, in which the difference of flow resistance, caused by the temperature dependence of liquid viscosity, is utilized as the basis of the valve effect [10]. A micromachined

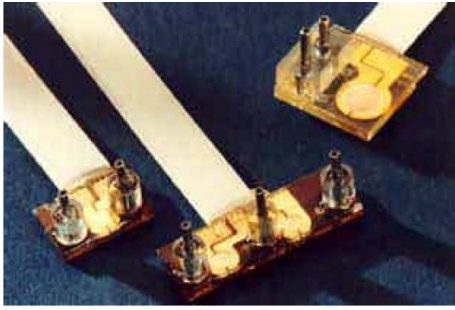

Figure 3. Examples of micropump prototypes developed at Karlsruhe University (from [13]).

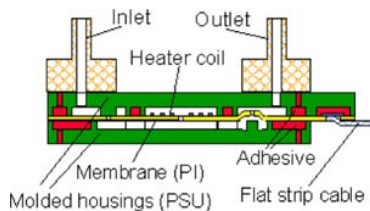

Figure 4. Schematic diagram of a micropump (from [13]).

electrochemical pump has been fabricated by the MESA Research Institute, Twente, The Netherlands. This pump is capable of dosing precise nanolitre amounts of liquid. The structure, shown in figure 2, is obtained in silicon by reactive ion etching and covered with a bonded Pyrex piece with noble metal electrodes. The structure can be easily integrated in miniaturized chemical analysis systems to dose reagents or calibration solutions [11].

Pneumatic- and laser-driven peristaltic micropumps have been developed by Aisin Cosmos R&D Co, Ltd [12]. Micropumps, and active and passive valves have been developed at Forschungszentrum Karlsruhe, Germany, by using a process combining moulding, surface micromachining and membrane transfer, called AMANDA (Abformung Oberflächenmicrome-chanik und membranübertragung). The housing parts of the devices are fabricated by injection moulding or hot embossing of thermoplastic polymers (PMMA, PE, PEEK, PVDF); in the housing, a thin structured membrane is attached by a transfer process. The devices and schematic diagram are shown in figures 3 and 4 [13].

Ultrasonic microfluidic devices have been developed at the University of California at Berkeley (UCB). These devices are able to perform fluidic functions such as pumping, stirring, filtering, and manipulation of gases and liquids, cells, bacteria and other biological substances.

Views of an ultrasonic flexural plate wave device are shown in figure 5 [14].

Ultrasonic-driven micromachined silicon needles, shown in figure 6, were proposed by White *et al* [14]. When the needle tip is immersed in a liquid and is driven ultrasonically, the hollow shaft acts as a pump.

Silicon micromachining has also been found to be a viable method for the fabrication of semipermeable membranes, because of its good mechanical and thermochemical stability, biocompatibility, ease of sterilization and ease of surface modification for low protein adsorption.

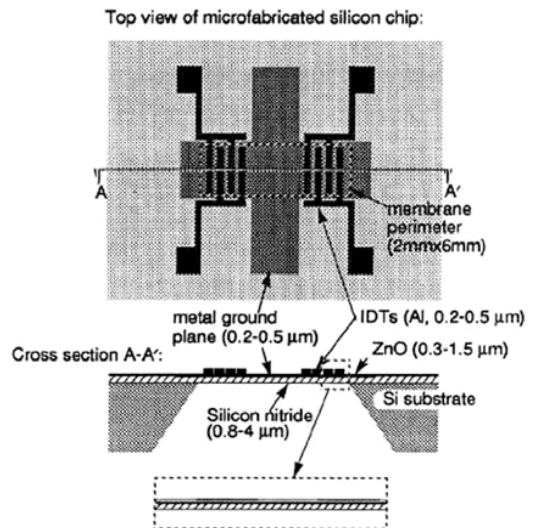

Figure 5. Schematic diagrams of an ultrasonic flexural plate wave device (from [14]).

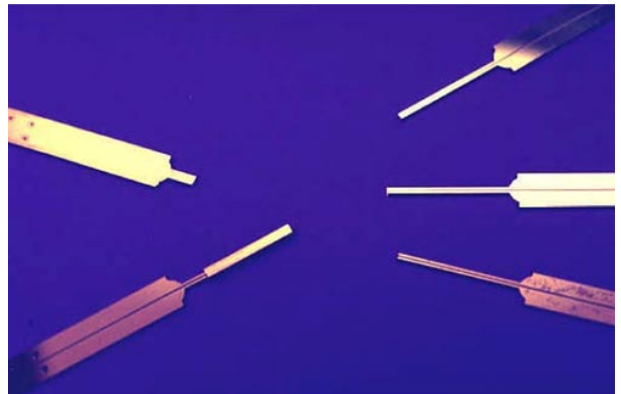

Figure 6. Micromachined ultrasonic needles (from [14]).

A directly bonded silicon filter for filtration of sub 100 nm particles has been fabricated at UCB [15]; the filter can trap particles as small as 44 nm. Besides silicon and micromachining, other materials and techniques can be exploited for fabricating microfluidic devices and can open new perspectives for liquid handling devices.

A UV-laser ablation method has been described for the production of miniaturized liquid handling systems on polymer substrate chips [16]. Channels were fabricated in polystyrene, polycarbonate, cellulose acetate and poly(ethylene terephthalate) [17, 18]. Many diagnostic and analysis systems could be fabricated using UV-laser ablation, i.e. μ -TAS systems, with enzyme-sensing zones deposited inside polymer channels, for the detection of substances of toxicological interest.

A new technology has been developed for fabricating re-configurable microfluidic circuits [8, 19]. This technology, which is based on moulding of polydimethylsiloxane (PDMS), is called three-dimensional (3D) micro-moulding, and allows fluid components to be developed rapidly and efficiently. PDMS has also been used in MST for making gas-permeable membranes for cell cartridges and disposable devices for DNA analysis.

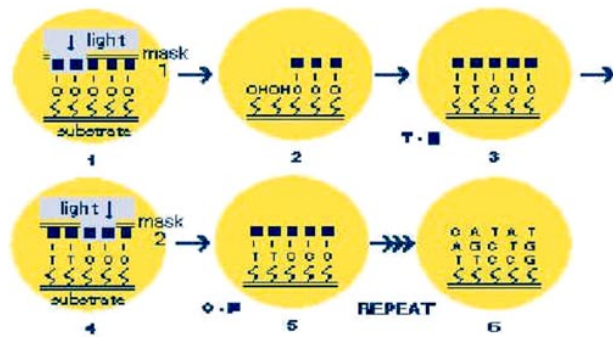

Figure 7. The GeneChip probe array synthesis process (Affimetrix Inc, Santa Clara, California, USA).

Other very interesting areas of potential application of micromechanics in medicine are genetics and applied bio-genetic technology. Microfabricated devices utilizing microfluidic subsystems are expected to provide the next generation of inexpensive tools for DNA diagnostics. The main objective of DNA diagnosis is the development of a simple, accurate and cheap technique for DNA screening, useful for:

- (1) prevention (to localize a specific genetic mutation present in cells);
- (2) diagnosis and therapy (to understand if the gene of interest is ‘turned on’ and active in cells).

The method used for DNA screening consists of matching between original and unknown DNA fragments (hybridization) in order to discover possible gene mutations. The traditional approach for DNA screening is quite expensive and time consuming: it involves the breakdown of the specimen to analyse, the extraction of the nucleic acids, the selection and amplification of the gene (or sequence) of interest, and the labelling for the final detection.

The newly developed DNA chips represent a powerful technique for DNA screening. DNA chips have small size, allow a large reduction of sample and reagent consumption, are quick and can also be used simply by untrained operators. DNA-chip technology is essentially based on the integration of chemical synthesis technology (for specimen breakdown and nucleic acid extraction) and of IC technology (for photolithography). Wells for DNA deposition and microchannels for electrophoretic DNA separation can be obtained by inexpensive bulk manufacturing. Photolithography can be used to grow separate oligonucleotide strands on a substrate. If large pieces of DNA (consisting in gene fragments or cDNAs) have to be dispersed in suitable locations of the substrate and then hybridized, spraying techniques similar to those used in inkjet printers are preferred. The DNA probe size can be $8 \mu\text{m} \times 8 \mu\text{m}$, or even smaller. Using these technologies as many as 10^6 probes cm^{-2} can be fabricated [4].

A typical procedure for DNA probe array synthesis is illustrated in figure 7. A photo-protected glass substrate is selectively illuminated by light passing through a photolithographic mask. Then, the deprotected areas are activated and chemical coupling occurs at the activated positions. The next step consists of the application of a new

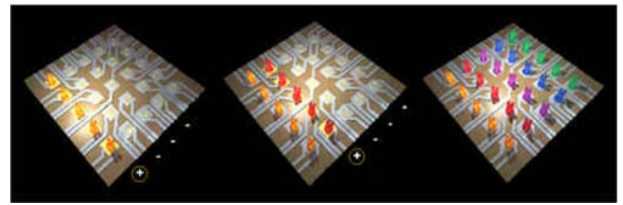

Figure 8. DNA probes electronically addressed to the microchip (from [20]).

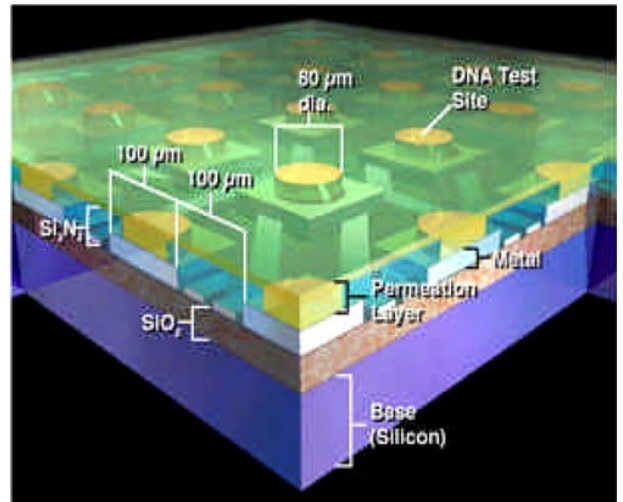

Figure 9. A view of the microchip structure (from [20]) developed by Nanogen Inc., San Diego, California, USA.

mask pattern, and the coupling step is repeated. The process continues until the desired set of probes is obtained.

A different system for DNA analysis was proposed by Nanogen Inc, San Diego, California, USA [20]. The system consists of a disposable cartridge containing a microchip with electrical and fluidic connections to a fully-automated instrument that controls all the aspects of microchip operation, processing, detection and reporting. DNA is negatively charged, so it can be electronically moved to an area of positive charge. A test site on the microchip is electronically activated with a positive charge. A solution of DNA probes is introduced onto the microchip. The negatively charged probes rapidly move to the positively charged sites, where they concentrate and are chemically bound to that site. Site by site, row by row, an array of specifically bound DNA probes can be addressed or assembled on the microchip.

In figure 8 five sets of different capture probes have been electronically addressed to the microchip [20]. The microchip is coated with a permeation layer to which capture probes are attached and it is mounted on the disposable cartridge. A view of the structure is shown in figure 9. Nanogen expects that the disposable cartridge and microchip can be produced in high volumes at low costs.

The DNA-chip market promises to be explosive: in fact many new companies have been established in the last few years, especially in USA and in Germany, with the aim of engineering DNA chips and of commercializing them. The main factors which ‘drive’ the development of the diagnostic-systems market are the importance of the medical

applications (e.g. diagnosis of many diseases by means of chemical parameters detection, DNA screening for genetic diseases) and the social impact (e.g. prevention of genetic diseases by low-cost and non-invasive techniques, crime prosecution, etc).

The ultimate goal for μ TAS and DNA chips is to measure chemical parameters of significance and eventually all human genes on a single chip—following the guidelines and the preliminary results of the Genoma Project. This goal requires the development of complex systems, including biosensors, microfluidic components (such as conduits, valves and pumps) and microelectronics, which have to be positioned, assembled and packaged on the same substrate. A critical aspect of diagnostic micro-systems is sensitivity: in fact, using small sample volumes at low concentration, there is a high probability that the analyte is undetectable, because the sample could contain less than one single target molecule.

3. Drug delivery systems

Research on new techniques for drug delivery seeks to develop tools capable of delivering precise quantities of a drug at the right time and as close to the treatment site as possible. Both implanted and transdermal drug delivery systems have been investigated using microfabrication technologies.

Transdermal drug release can be an attractive alternative for drugs which cannot be effectively delivered using pills and injections; in fact it overcomes the limitations related to gastrointestinal drug degradation and the inconvenience and pain related to intramuscular and intravenous injections.

At present, only transdermal delivery systems driven by passive diffusion through the skin are approved for clinical use. Such systems are useful only for small and lipophilic molecules in small doses. More intelligent and flexible devices for transdermal drug delivery could be developed using MST.

Improving the present passive delivery systems requires increasing rates of transport across the skin. Several approaches have been considered to achieve this goal: microfabricated needles, chemical enhancers, iontophoresis, ultrasound and electroporation. An array of micromachined needles for drug delivery is shown in figure 10. The array was fabricated using the so-called ‘black silicon method’, a reactive ion etching process in which an SF₂/O₂ plasma etches silicon anisotropically [21]. Low-frequency ultrasound can make feasible transdermal release of proteins such as insulin, interferon γ and erythropoietin across human skin [22].

Implantable devices are preferred for therapies that requires many injections daily or weekly. Apart from a reduction of the number of injections, implantable drug delivery systems have many other advantages: drug level in the blood could be adapted to variations in physical activity (if drug level is monitored on-line); in some treatments, such as chemotherapy, the device can be implanted at the place where the drug is needed.

Active devices for drug delivery generally require a precise pumping mechanism. Active implantable devices for both solid and liquid drug delivery, actuated by shape memory alloys, have been developed by Reynaerts *et al* [23].

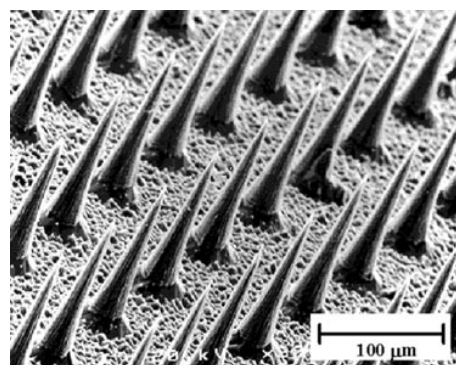

Figure 10. Micromachined needles for transdermal drug release (from [21]).

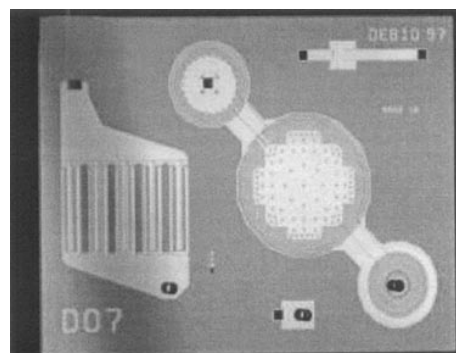

Figure 11. Micropump chip developed by Maillefer *et al* (from [24]).

A micropump for controlling low flow rates of liquid drugs with high precision and long-term reliability and safety is shown in figure 11. The micropump is the heart of an implantable drug delivery system fabricated by silicon bulk micromachining and silicon pyrex anodic bonding, and incorporating piezoelectric actuators [24]. This system can be used, for example, for insulin infusion in diabetic patients.

Recently a unique solid-state silicon microchip for controlled release of single or multiple chemical substances on demand was developed by Santini *et al* [25]. The release mechanism is based on the electrochemical dissolution of a gold membrane covering the reservoirs. The chip contains 34 reservoirs connected one by one to an external power source. Other electrodes as cathodes are on the surface of the microchip. If a release of a reservoir is desired an electrical voltage, approximately 1 V, is applied between the anode and cathode. The anode (the gold membrane that covers the reservoir) dissolves and the drug inside diffuses out into the surrounding fluid. Each reservoir can be activated individually. Gold was chosen as material for the anode because it has a low reactivity with other substances, it resists spontaneous corrosion in many solutions over the entire pH range, it is easily deposited and patterned, and it is biocompatible. The front and back views of the microchip are shown in figure 12. The dots between the three large bars (cathodes) are the caps (anodes) covering the reservoirs that hold chemicals. The back view shows the larger openings for each reservoir through which chemicals are deposited, after the reservoirs are filled these openings are sealed by a waterproof material.

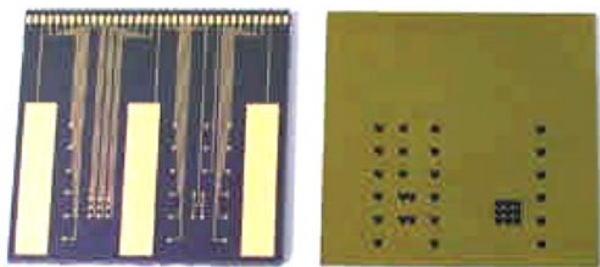

Figure 12. Front (left) and back (right) views of the controlled release microchip (from [25]).

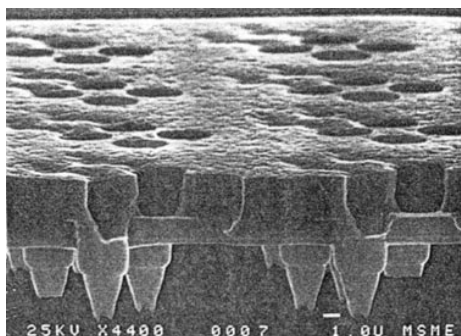

Figure 13. Micrograph of cross sectional view of biocapsule membrane (from [27]).

Polymeric nanospheres as nanoparticulate carriers have been investigated for site specific drug delivery by Langer *et al* [26]. A physiological method for treating insulin-dependent diabetic people consists of the transplantation of insulin-secreting cells. These cells are rapidly destroyed by immune rejection if not protected. Protection of insulin-secreting cells has been reached via their encapsulation with semi-permeable membranes, but real polymeric membranes often present thermal, chemical and mechanical instabilities and broad pore size distribution. Therefore, new technologies for cell encapsulation are investigated in order to surmount limitations related to polymeric membranes.

Microfabricated biocapsules [27] as *in vivo* insulin-secreting bioreactors have been developed. The biocapsule membrane (figure 13) consists of a surface micromachined membrane enclosing a cell-containing recess which is anisotropically etched into a single-crystal silicon wafer that provides mechanical support.

The main driving factor of the development of MST-based drug delivery systems is the need for optimal control of therapy. This implies an accurate ‘tuning’ of the drug administration parameters and monitoring of the efficacy of therapy. Although possible in principle using MST, this goal could remain elusive if challenging technical problems such as the development of reliable microfluidic components and, above all, of suitable biosensors are not solved.

4. Tissue engineering

Tissue engineering is an emerging interdisciplinary field which applies the principles of biology and engineering to the development of viable substitutes which restore, maintain, or improve the function of human tissues [28]. Some of the

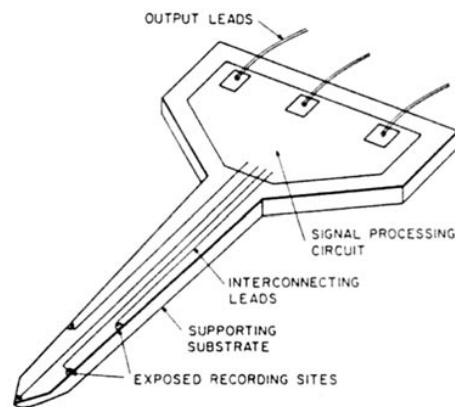

Figure 14. Silicon probe for neural recording (from [29]).

most promising fields of application of tissue engineering are: nerve regeneration, development of bioartificial organs, bone and vessel re-growth and skin substitution. The authors have investigated the problem of interfacing peripheral nerves with micro-systems: therefore in the following some problems related to nerve regeneration and interfacing will be addressed. The substitution or regeneration of damaged parts of the nervous system implies the record of activity and selective stimulation of neurons, as preliminary and fundamental steps.

One of the first examples of microelectrodes for recording and stimulating is the probe in silicon (figure 14), for high-amplitude multichannel monitoring of neural activity in the cortex, developed by Najafi *et al* [29].

Over the last few years a number of multi-electrode systems for nervous stimulation, many exploiting silicon micromachining techniques, have been developed. Silicon micromachined structures, in which cultured neurons can be implanted and grown, are described in [30]. The structures are neuron wells fabricated in a 20 μm thick silicon membrane. Smart microchips for culture, stimulation, and recording of neural cells arrays have also been developed [31]. The microchips include a 4 \times 4 array of indium–tin oxide electrodes, passivated outside of measurement areas by polymeric layers.

When electrical stimulation is used to stimulate motor neurons it is called functional neuromuscular stimulation (FNS). Over the last two decades three generations of FNS systems have been developed.

Discrete non-implantable devices characterized the first generation. In the second, the stimulator size was reduced by microelectronics techniques; multichannel stimulators were developed, characterized by a central module connected by long wires to distant sites. The most recent generation is featured by single-channel stimulators. A single-channel implantable microstimulator [32] for functional neuromuscular stimulation is shown in figure 15.

Neuro-electronic interface devices for selective artificial stimulation of peripheral nerve motor fibres were developed by Rutten *et al* [33]. Each fibre is connected by its own interface to the electronic world. The dimensions of the electrodes are in the micrometre range in order to be implantable and selective. Because the number of fibres in an average fascicle is of the order of a few hundred and the

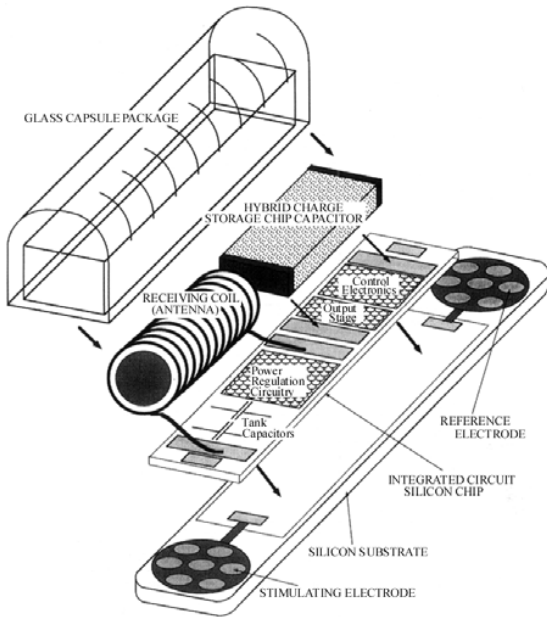

Figure 15. Single-channel, implantable microstimulator (from [32]).

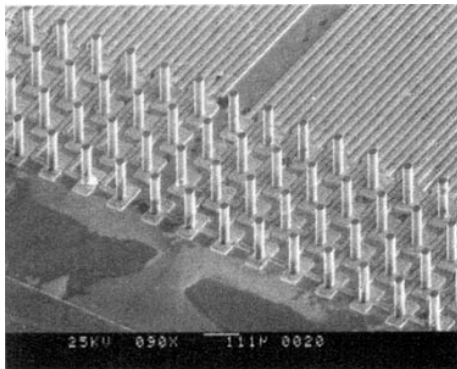

Figure 16. Array of microneedles for selective nerve stimulation (from [33]).

architecture of a fascicle is not precisely known, the current approach is to design and fabricate a redundant number of microelectrodes in 3D arrays. A non-traditional fabrication technique for microelectrodes is silicon micromachining combined with LIGA [33]: arrays of 4×32 needle electrodes obtained by this technique are illustrated in figure 16.

A class of implantable, regeneration-type neural interfaces (NIs) for mammalian peripheral nerve recording and stimulation were developed in the framework of a project promoted by the European Commission ('INTER' Esprit Project No 8897). The interface is comprised of three components (figure 17): a microfabricated silicon die with microelectrode array on multiple through holes, a polymer guidance channel housing the die, and a flexible flat cable connecting the die to external electronic circuitry [34].

A different approach for interfacing peripheral nerves consists of cuff-type connectors, such as those fabricated by Schuettler *et al* [35]. The connectors are based on micromachined polyimide substrate and insulation layers with embedded thin-film metallization. A rolled cuff-type electrode is shown in figure 18.

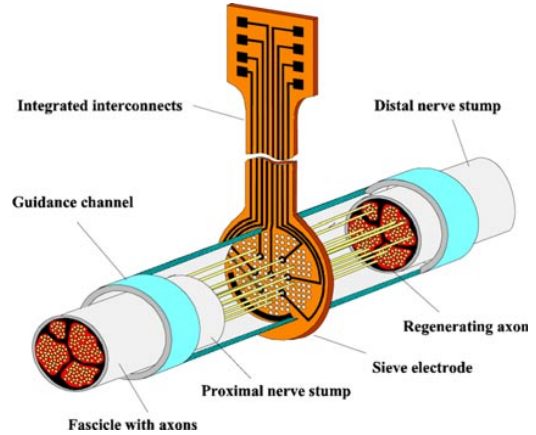

Figure 17. Schematic diagram of the regeneration-type NIs.



Figure 18. Rolled cuff-type electrode (from [36]).

Current research efforts towards the development of neural connectors for nerve recording and stimulation are leading to new vision and perspectives for prosthetics. In this framework, the GRIP Project (Esprit Long Term Research No 26322) intends to combine NI (neural connector and telemetry system) and artificial sensor signal processing in order to develop a functional electrical stimulation (FES) system exploiting artificial sensors [36].

The future of this ambitious project is twofold: first, the development of cybernetic prostheses; second, the development of a FES system using afferent nervous signals. MST is a fundamental enabling technology of this class of projects. The technical complexity of neural prostheses is very high, especially in terms of nervous signal selectivity, long-term stability, tissue compatibility and minimal invasiveness. On the other hand, the social (even if probably not commercial and financial) impact of these classes of micro-systems could be significant.

5. MIS

Minimally invasive therapy (MIT) and MIS seek to provide to the patient, the medical doctor and the health-care system many advantages in terms of better quality of care, shorter hospitalization and reduction of pain and medical complications. MIT and MIS techniques are well established in some medical fields, for example laparoscopy and arthroscopy, but new fields of application are currently investigated and considered as very promising, such as local treatment of tumours and single-cell surgery.

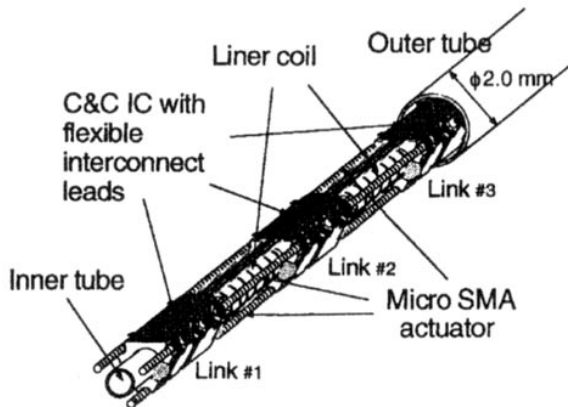

Figure 19. Active microcatheter with integrated circuits (from [39]).

Limited access to the target organ and reduced amount of information (visual and tactile) available to the surgeon for planning the operation are important limitations of MIT and MIS. These limitations can be addressed by micromechanics and MST, which could allow one to increase the performance of the miniature instrumentation and to enhance feedback to the surgeon by adopting micromechatronic design and by incorporating miniaturized actuators and sensors.

Active catheters with multiple tactile sensors mounted on the tip have been designed and fabricated by Olympus Optical Co., Tokyo, Japan [37]. The catheter incorporates two SMA wire bending actuators. The tactile sensors are fabricated monolithically on flexible film using thinned integrated circuits (the so-called MIF technology [38]). The MIF system includes three tactile sensors, one passive sensor for temperature compensation and aluminium connection wires.

A polymer-links microcatheter, less than 2 mm in diameter, with integrated CMOS interface circuits for communication and control has been developed at Tohoku University, Japan [39]. The actuation is SMA-based: each SMA actuator is driven individually, thus allowing a selectable bending of the catheter. A view of the system is shown in figure 19.

As already indicated, one of the most important problems for the surgeon is the limited visual information available during MIS: as a consequence, the surgeon has problems in identifying the position of the surgical tool with respect to the internal organ being operated upon. Many solutions have been devised and new devices fabricated to overcome this problem and to provide high-resolution 3D vision to the surgeon. A mechatronic tool and a system for computer-assisted arthroscopy have been developed by the authors in collaboration with partners of a European Project [40]. The arthroscope is at the same time a smart tool for traditional arthroscopy and the main component of an augmented-reality navigation system. The mechatronic arthroscope has a cable-actuated, servomotor-driven, multi-joint mechanical structure; it is equipped with a position microsensors measuring the orientation of the tip and with a force microsensors detecting contact with delicate tissues in the knee; and, finally, it incorporates an embedded

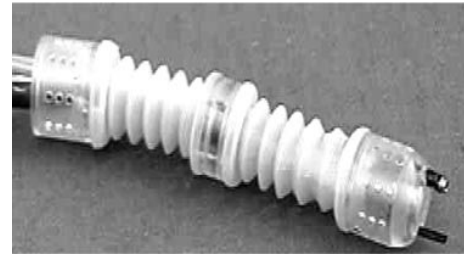

Figure 20. Mini-robot for colonoscopy.

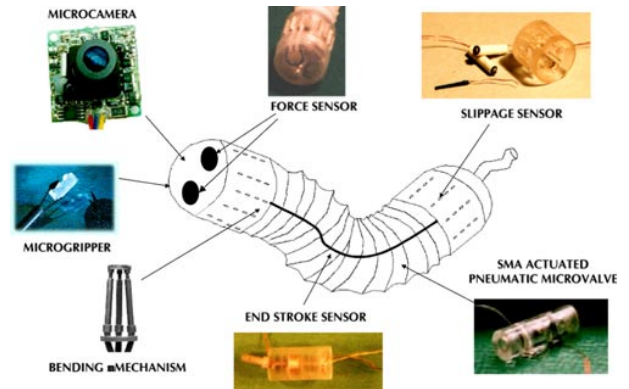

Figure 21. Concept of minirobot for MIT and MIS, with existing miniature components.

microcontroller for sensor signal processing, motor driving and interfacing with the surgeon and the system control unit.

Another surgical branch in which it is desirable to reduce trauma and pain for patients, in order to perform systematic, frequent and effective diagnostic procedures, is endoscopy and, in particular, colonoscopy.

A possible approach is to exploit in colonoscopy is intelligent, flexible and semi-autonomous mini- and micro-robots for inspection. A unique mechatronic system for colonoscopy, pneumatically actuated, has been developed by some of the authors [41]. The main modules of the mini-robot system are the mothership, the miniature pneumatic distributor, the human/machine interface and the control system. A current version of the mini-robot is shown in figure 20. Components already integrated on board include a CCD camera for visualization, a fibreoptic bundle for illumination, a water channel for flushing (cleaning of lenses), an air channel for opening the lumen and a working channel for introducing tools for biopsy.

Our long-term design goal is a highly-integrated, semi-autonomous, micromechatronic system. Components to be integrated on board in the future version of the mothership include: a micromechanism for bending and elongation (a Stewart platform actuated by micromotors currently under development), microarms with microtools for surgery and several sensors for tool localization, and for end-stroke, force and slippage control.

A concept of a future integrated micromechatronic system for colonoscopy and, in general, for introduction through natural orifices is shown in figure 21.

MIT and endoscopy procedures, including colonoscopy, could take great advantage from the enhancement of

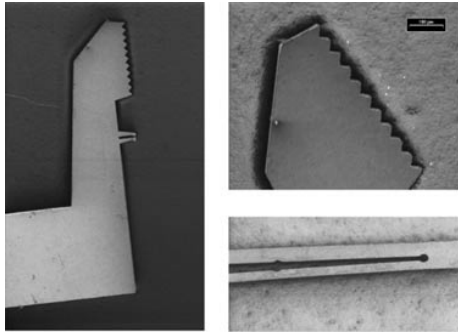

Figure 22. SEM micrographs of a nickel microgripper (from [43]).

visualization systems. Future endoscopic units should offer higher resolution, increased miniaturization, higher automation, better image processing and advanced diagnostic imaging features. The MEDEA Project (BIOMED 2—No BMH4-CT97-2399), in which authors are involved, aims to develop a microscanner module located at the front end of an endoscope.

The novel microcamera is based on confocal scanning, combined with multiple laser illumination and electronic control along with image processing and handling of the received output. The main clinical benefits expected by the proposed endoscopic system derive from the very high resolution of the new scanning module: for example, high-resolution colonoscopy could allow early diagnosis of colon cancer.

One of the main challenges for future MIS is microsurgery in minute working spaces and, ultimately, even cell microsurgery. Cell surgery obviously requires high dexterity and high-quality visualization; a solution to these requirements is to develop suitable instrumentation of a size 'comparable' with micro-objects. To this aim a variety of microgrippers have been developed over the last few years. These devices should have small size, be able to operate in biological liquids and to allow for precise control of grasping forces in order to avoid cell damage.

A gripper for micro-objects manipulation in biological liquids, fabricated using bulk and surface micromachining, was developed at UCLA [42]. The device takes inspiration from the structure of a sea anemone, which entraps its prey with its tentacles. The gripper has the shape of a microcage with a flexure that opens and closes by pneumatic actuation. The cage geometry is realized by a radial array of 12 beams, whilst the cage platform is an oxide-on-latex membrane.

LIGA-fabricated microgrippers for biological application have been developed and tested in the authors' laboratory [43]. The grippers have piezoelectric microactuators and are integrated with position Hall-effect sensors and strain gauges to control grasping and to provide the operator with position and force feedback. Some features of a prototype microgripper are illustrated in figure 22.

Minimally invasive surgical techniques have many advantages when compared to traditional ones and thus the driving force towards the development of better (that is miniaturized and high-performance) tools, as allowed

by MST, is very strong. However developing usable microinstruments for MIS requires the solution of many critical problems, such as safety, sterilization and calibration of non-disposable devices. Dealing with increasingly severe regulatory issues is a most severe obstacle, in terms of costs and time to market, to the clinical (and thus industrial) exploitation of MST-based MIS instrumentation.

6. Conclusions

In this paper we have discussed the state of the art and perspectives of some classes of micro-systems for medical applications. For each class some of the most interesting devices have been described and a qualitative analysis of the complexity and the time to development has been proposed. Our intention was to provide the reader with a feeling of the concrete problems and opportunities encountered in this field, many of which have a value beyond the specific applications we have considered.

A lesson learned from the review and analysis is that critical design and technological problems exist in the fields of microsensors, microactuators and micromechanisms, and that special attention is required by the proper choice of biocompatible materials and packaging.

The role of MST in biomedical application will certainly grow further because of their many potential advantages, such as disposability (which limits the possibility of infection), small size (minimum pain for the patient), high-volume production and consequently potential low cost, proved characteristics of reliability and reproducibility. However, and in conclusion, one should consider that in the biomedical field the usual bottleneck in the transfer from research prototypes to real marketable products is particularly severe. Typical costs associated with engineering research and design is only 5% of the total cost to market; whereas 95% of such costs are connected to the production tooling, personnel training and, especially, to regulatory compliance. The average time to market from proof of concept of new biomedical devices is about five years. These figures could become even more severe for the case of new components and devices, such as those based on MST.

Acknowledgments

The authors' work was supported by the GRIP (An Integrated System for the Neuroelectric Control of Grasp in Disabled Persons) ESPRIT Project, the MIAS (Minimally Invasive Articular Surgery) BIOMED II Project, the MUSYC (A Multifunctional Minirobot System for Endoscopy) BIOMED II Project, the MEDEA (Microscanning Endoscope with Diagnostic and Enhanced Resolution Attributes) BIOMED II Project, and the MINIMAN (Miniaturized Robot for Micro-Manipulation) ESPRIT Project, all funded by the European Commission.

References

- [1] Dario P, Carrozza M C, Allotta B and Guglielmelli E 1996 Micromechatronics in medicine *IEEE/ASME Trans. Mechatronics* **1** 137–48

- [2] Hitchings D J and Wilkinson J M 1999 Visions of MST in medicine *MSTnews* **4** 12–13
- [3] 1996–2002 NEXUS Task Force Market Analysis for microsystems
- [4] Abramowitz S 1999 DNA analysis in microfabricated formats *J. Biomedical Microdevices* **1** 107–12
- [5] Petersen K E, McMillan W A, Kovacs G T A, Allen Northrup M, Christel L A and Pourahmadi F 1998 Towards next generation clinical diagnostic instruments: scaling and new processing paradigms *J. Biomedical Microdevices* **1** 71–9
- [6] Accoto D, Carrozza M C and Dario P 1999 Modelling of micropumps using unimorph piezoelectric actuator and ball valves *Proc. 10th Workshop on Micromachining Micromechanics and Microsystems—Micro Mechanics Europe (MME '99) (Gif-sur-Yvette, France, September 27–28, 1999)* pp 259–62
- [7] Hosokawa K, Fujii T and Endo I 1999 Droplet-based nano/picoliter mixer using hydrophobic microcapillary vent *Proc. IEEE MEMS '99 (Orlando, FL, January 17–21, 1999)* pp 388–93
- [8] Dario P, Carrozza M C, D'Attanasio S, Lencioni L and Magnani B 1996 SMA-based pneumatic mini-valves for a medical microrobot *Proc. 7th Workshop on Micromachining Micromechanics and Microsystems—Micro Mechanics Europe (MME 96), (Barcelona, Spain, October 21–22, 1996)* pp 212–15
- [9] Rich C A and Wise K D 1999 An 8-bit microflow controller using pneumatically-actuated microvalves *Proc. IEEE MEMS '99 (Orlando, FL, January 17–21, 1999)* pp 130–4
- [10] Matsumoto S, Klein A and Maeda R 1999 Development of bi-directional valve-less micropump for liquid *Proc. IEEE MEMS '99 (Orlando, FL, January 17–21, 1999)* pp 141–6
- [11] Bohm S, Olthuis W and Bergveld P 1999 An integrated micromachined electrochemical pump and dosing system *J. Biomedical Microdevices* **1** 121–30
- [12] Naruse Y 1999 Design and fabrication of a peristaltic micro pump *Proc. Italy–Japan Joint Seminar on Micromachines (Pisa, Italy, June, 1999)*
- [13] <http://www.fzk.de/pmt/englisch/default.htm>
- [14] <http://www-bsac.eecs.berkeley.edu/fluidics/>
- [15] Tu J K, Huen T, Szema R and Ferrari M 1999 Filtration of sub-100 nm particles using a bulk micromachined direct-bonded silicon filter *J. Biomedical Microdevices* **1** 113–19
- [16] Roberts M A, Rossier J S, Bercier P and Girault H 1997 UV laser machined polymer substrates for the development of microdiagnostic systems *Anal. Chem.* **69** 2035–42
- [17] Lee L P, Berger S A, Liepmann D and Pruitt L 1998 High aspect ratio polymer microstructures and cantilevers for bioMEMS using low energy ion beam and photolithography *Sensors Actuators A* **71** 144–9
- [18] Schwarz R, Rossier J S, Bianchi F, Reymond F, Ferrigno R and Girault H H 1998 Micro-TAS on polymer substrates micromachined by laser photoablation *Proc. μ TAS '98 Workshop (Banff, Canada, October 13–16, 1998)* 241–4
- [19] Armani D, Liu C and Aluru N 1999 Re-configurable fluid circuits by PDMS elastomer micromachining *Proc. IEEE MEMS '99 (Orlando, FL, January 17–21, 1999)* pp 222–7
- [20] <http://www.nanogen.com/tech.htm>
- [21] Henry S, McAllister D V, Allen M G and Prausnitz M R 1998 Micromachined needles for transdermal delivery of drugs *Proc. IEEE MEMS '98 (Heidelberg, Germany, January, 1998)* pp 494–8
- [22] Mitragotri S, Blankschtein D and Langer R 1995 Ultrasound-mediated transdermal protein delivery *Science* **269** 850–3
- [23] Reynaerts D, Peirs J and Van Brussels H 1997 An implantable drug delivery system based on shape memory alloy micro-actuation *Sensors Actuators A* **61** 455–62
- [24] Maillefer D, van Lintel H, Rey-Mermet G and Hirschi R 1999 A high-performance silicon micropump for an implantable drug delivery system *Proc. IEEE MEMS '99 (Orlando, FL, January 17–21, 1999)* pp 541–6
- [25] Santini J T, Cima M and Langer R 1999 A controlled-release microchip *Nature* **397** 335–8
- [26] Gref R, Minamitake Y, Peracchia M, Trubetskoy V, Torchilin V and Langer R 1994 Biodegradable long-circulating polymeric nanospheres *Science* **263** 1600–3
- [27] Desai T A, Chu W, Rasi G, Sinibaldi-Vallebona P, Guarino E and Ferrari M 1999 Microfabricated biocapsules provide short-term immunoisolation of insulinoma xenografts *J. Biomedical Microdevices* **1** 131–8
- [28] Langer R and Vacanti J 1993 Tissue engineering *Science* **260** 920–6
- [29] Najafi K, Wise K D and Mochizuki T 1985 A high-yield IC-compatible multichannel recording array *IEEE Trans. Electron. Devices* **32** 1206–11
- [30] Tatic-Lucic S, Wright J A, Tai Y and Pine J 1997 Silicon cultured-neuron prosthetic devices for *in vivo* and *in vitro* studies *Sensors Actuators B* **43** 105–9
- [31] Heuschkel M O, Guerin L, Buisson B, Bertrand D and Renaud P 1998 Buried microchannels in photopolymer for delivering of solutions to neurons in a network *Sensors Actuators B* **48** 356–61
- [32] Ziaie B, Nardin M D, Coghlan A R and Najafi K 1997 A single-channel implantable microstimulator for functional neuromuscular stimulation *IEEE Trans. Biomedical Eng.* **44** 909–20
- [33] Rutten W L C, Smit J P A, Frieswijk T A, Bielen J A, Brouwer A L H, Buitenweg J R and Heida C 1999 Neuro-electronic interfacing with multielectrode arrays *IEEE Eng. Med. Biol.* **3** 47–55
- [34] Dario P *et al* 1998 Neural interfaces for regenerated nerve stimulation and recording *IEEE Trans. Rehabilitation Eng.* **6** 353–63
- [35] Schuettler M, Stieglitz T and Meyer J-U 1999 A multipolar precision hybrid cuff electrode for FES on large peripheral nerves *Proc. 21st Ann. Int. Conf. of the IEEE Engineering in Medicine and Biology Society (Atlanta, GA, October 13–16, 1999)* p 383
- [36] <http://www.grip-europe.org/>
- [37] Takizawa H, Tosaka H, Ohta R, Kaneko S and Ueda Y 1999 Development of a microfine active bending catheter equipped with MIF tactile sensors *Proc. IEEE MEMS '99 (Orlando, FL, January 17–21, 1999)* pp 412–17
- [38] Kaneko S, Asaoka, Tosaka H, Ohta R and Yanagisawa K 1997 Monolithic fabrication of flexible film and thinned integrated circuits *Proc. MEMS '97 (Nagoya, Japan, January 26–30, 1997)* pp 471–6
- [39] Park K and Esashi M 1999 An active catheter with integrated circuit for communication and control *Proc. IEEE MEMS '99 (Orlando, FL, January 17–21, 1999)* pp 400–5
- [40] Dario P, Carrozza M C, Marcacci M, D'Attanasio S, Magnani B, Tonet O and Megali G 2000 A novel mechatronic tool for computer-assisted arthroscopy *IEEE Trans. Inform. Technol. Biomed.* **4** 15–29
- [41] Dario P, Carrozza M C and Pietrabissa A 1999 Development and *in vitro* testing of a miniature robotic system for computer-assisted colonoscopy *Comput. Aided Surgery* **4** 1–14
- [42] Ok J, Chu M and Jin C 1999 Pneumatically driven microcage for micro-objects in biological liquids *Proc. IEEE MEMS '99 (Orlando, FL, January 17–21, 1999)* pp 459–63
- [43] Carrozza M C, Dario P, Mencias A and Fenu A 1998 Manipulating biological and mechanical micro-objects using LIGA-microfabricated end-effectors *Proc. 1998 IEEE Int. Conf. on Robotics and Automation (Belgium, May, 1998)* pp 1811–16