

## MICROSTRIP LINE AND CPW FED ULTRA WIDEBAND SLOT ANTENNAS WITH U-SHAPED TUNING STUB AND REFLECTOR

R. Chair, A. A. Kishk, K. F. Lee, C. E. Smith, and D. Kajfez

Department of Electrical Engineering  
Center for Applied Electromagnetic Systems Research (CAESR)  
University of Mississippi  
University, MS 38677, USA

**Abstract**—Wideband printed rectangular slot antennas backed with reflectors for unidirectional radiation patterns are investigated. A U-shaped tuning stub is used to improve the matching. Two different feeding mechanisms are introduced. A rectangular slot excited by microstrip line feed with a U-shaped tuning stub gives an impedance bandwidth of 110% ( $|S_{11}| < -10$  dB). When the rectangular slot is excited by a coplanar waveguide (CPW), it gives an impedance bandwidth of 120%. Both slot antennas radiate broadside across the matching band, with front-to-back ratios of 20 dB.

### 1. INTRODUCTION

Printed microstrip slot antennas have been extensively investigated in the last two decades [1–6]. This type of antennas are suitable for radar and satellite communications applications. The advantages of the slot antennas are low profile, lightweight, easy integration with monolithic microwave integrated circuits (MMICs) and stable radiation patterns. However, the drawback of slot antennas is bi-directional radiation. Recently, different types of bandwidth enhancement techniques on microstrip line fed slot antennas are reported [7–11]. One method is to use different shapes of tuning stubs to achieve wideband performance [7, 8]. Other methods use different slot shape, such as square, rectangular and ring slots with appropriate turning stubs. The impedance bandwidths of these antennas achieve as much as 100% [9–12].

Alignment problems are usually encountered with the fabrication of two layer printed circuit antennas. Although the matching of the antenna is not significantly affected when the microstrip line is off center, asymmetrical and higher cross-polarization level radiation patterns result. Etching the slot and the feed line on the same side of the substrate eliminates the alignment problem needed for etching on both sides of the substrate [13, 14]. The coplanar waveguide (CPW) is such a transmission line that can achieve this. In addition, the CPW has lower loss than the microstrip line. One promising application with the coplanar waveguide fed antenna techniques is that a fiber optics system can be integrated with the slot antenna. Recently, different types of CPW-fed slot antennas have been designed for wideband applications, achieving 50% bandwidth in a multi-slot design [15, 16] and 60% bandwidth by optimizing a tuning stub [17, 18]. As with microstrip line excitation, slot antennas excited by coplanar waveguides also have bidirectional radiation characteristics.

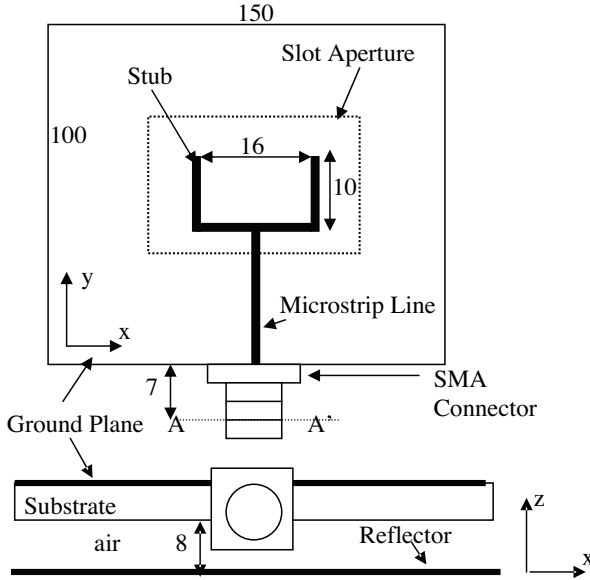
In this paper, unidirectional slot antennas with two different excitation methods are presented. Unidirectional radiation characteristics are obtained by adding a reflector to the traditional bidirectional slot antennas. One method of excitation is the microstrip line (MSL) feed, and the other is the coplanar waveguide (CPW) feed. A U-shaped tuning stub terminates both excitations. Without the reflector, both microstrip line fed and CPW-fed antennas give impedance bandwidth of 110% and 118%, respectively. With the reflector, unidirectional patterns are obtained, with impedance bandwidth of 110% and 120%, respectively for the two-excitation methods. One potential application of the ultra wideband slot antennas is the UWB communication system. Simulation results obtained from IE3D 10.1 [19] and Fidelity 4.2 [20] give reasonable agreement, although they assume the substrate, ground plane, and reflector to be infinite.

The paper is organized into four main sections. The first section is concerned with the slot antenna excited by microstrip line and the second section is on the CPW fed structures. Conclusions based on experience with this new type antenna are discussed in the last section of this paper.

## 2. MICROSTRIP LINE FED SLOT ANTENNAS WITH U-SHAPED TUNING STUB

### 2.1. Antenna Structures

Figure 1 shows the geometry of the proposed rectangular slot antenna with reflector. The antenna is excited by a  $50\Omega$  microstrip line with a U-shaped tuning stub. The slot has a length  $L = 21$  mm ( $0.42\lambda_0$ ) and

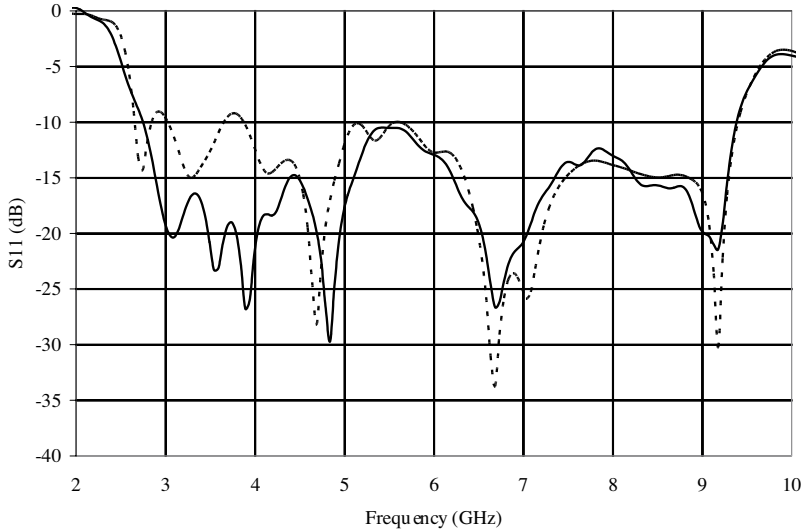


**Figure 1.** Geometry of the microstrip line fed slot antenna backed with reflector (units in mm).

width  $W = 32 \text{ mm}$  ( $0.64\lambda_0$ ), where  $\lambda_0$  is the free space wavelength at the center frequency 6.1 GHz. A dielectric substrate of  $\epsilon_r = 3.38$  and thickness  $t = 0.813 \text{ mm}$  is used. The width and the length of the  $50\Omega$  microstrip line is  $W_f = 1.88 \text{ mm}$  and  $L_f = 40.5 \text{ mm}$ , respectively. The dimension of the dielectric substrate is  $100 \text{ mm} \times 100 \text{ mm}$ . The distance between the reflector and the microstrip line is  $d = 8 \text{ mm}$ . Plastic screws are used to support the reflector and the dielectric substrate. Two different sizes of reflectors are studied, one has the same dimension as the dielectric substrate ( $100 \text{ mm} \times 100 \text{ mm}$ ) and the other one is larger ( $150 \text{ mm} \times 150 \text{ mm}$ ). The U-shaped tuning stub is located at the center of the slot, where the antenna is symmetrical along the center,  $y$ -axis. The total length and width of the U-shaped tuning stub are  $L_{stub} = 16 \text{ mm}$  and  $W_{stub} = 10 \text{ mm}$ , respectively. Detail dimensions and location of the U-shaped tuning stub are shown in Figure 1.

## 2.2. Results and Discussions

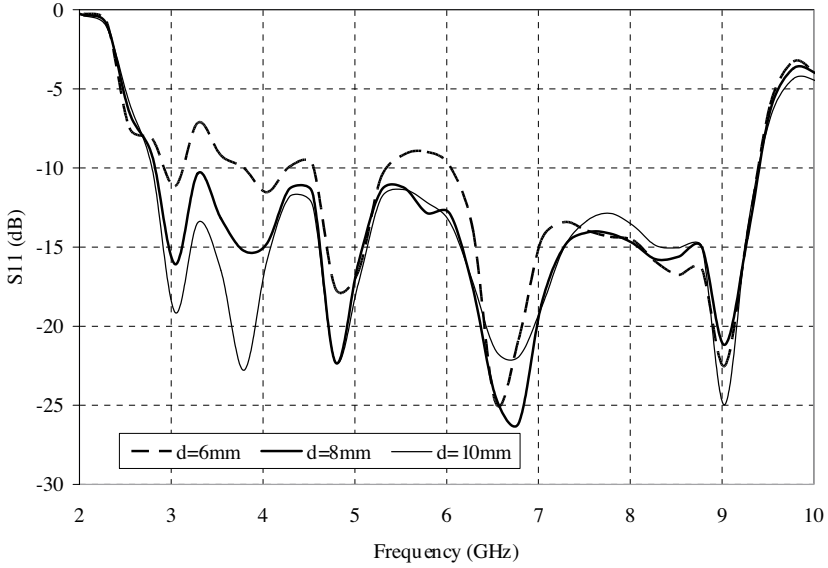
Figure 2 shows the measured return loss of the slot antenna with microstrip line fed and reflector as a function of frequency using an HP8510C vector network analyzer (VNA). The frequency domain measurement results are then transformed using the VNA time domain



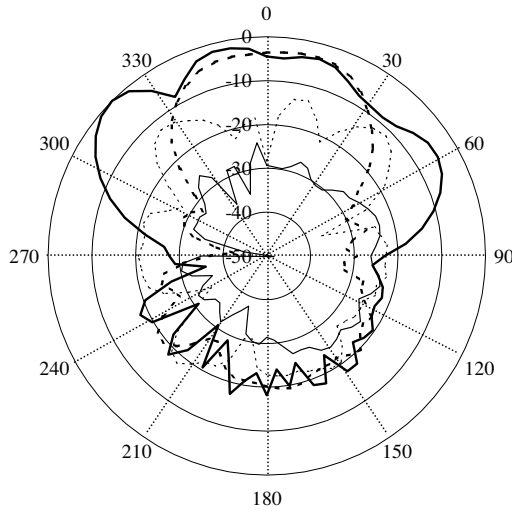
**Figure 2.** Measured and simulated return loss and gain of the microstrip line fed slot antenna with reflector — measured 150 mm  $\times$  150 mm, ..... measured 100 mm  $\times$  100 mm.

option, where the discontinuities due to the end-launch SMA connector are minimized with time gating. Two different size square reflectors are used, one is 150 mm  $\times$  150 mm and the other is 100 mm  $\times$  100 mm. Measured results show that the matching of the antenna is improved by using larger reflector. The matching bandwidth of the slot antenna (return loss  $< -10$  dB) with the larger reflector is from 2.74 GHz to 9.38 GHz (center at 6.1 GHz), equivalent to an impedance bandwidth of 110%. Figure 3 shows the measured return loss with different reflector separations  $d$ . It can be seen that the matching of the antenna is not only affected by the size of the reflector, but also affected by the distance from the reflector. The matching of the slot antennas gets worse when the distance of the reflector ( $d$ ) is less than 8 mm. The simulated gain is around  $4 \pm 3.5$  dBi across the matching band.

The measured radiation patterns at 9 GHz are presented in Figure 4. In addition, Figures 5a–5d show the simulated radiation patterns, which are obtained from Fidelity, at 3 GHz, 5 GHz, 7 GHz and 9 GHz, respectively. The differences between the simulation and measurement results are due to the assumption of infinite size dielectric substrate, ground and reflector in the simulation. The slot antenna backed with the reflector radiates in the broadside direction. As presented in Figure 4, the radiation pattern measured results show



**Figure 3.** Measured return loss with different distances between the reflector and dielectric substrate ( $d$ )  $---$   $d = 6$  mm,  $—$   $d = 8$  mm,  $—\diamond—$   $d = 10$  mm.



**Figure 4.** Measured radiation patten at 9 GHz (10 dB/Div)  $—$  E-Co,  $\dots\dots$  H-Co,  $—$  E-X,  $---$  H-X.

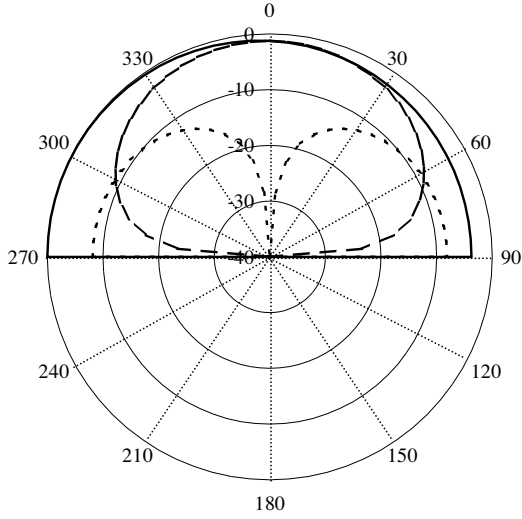
20 dB front-to-back ratios with a  $150 \text{ mm} \times 150 \text{ mm}$  reflector. The antenna is symmetrical along the  $yz$ -plane. Therefore, a symmetrical  $H$ -plane co-polarization pattern is obtained, while  $E$ -plane cross-polarization pattern is cancelled out. However, due to the feed line and the tuning stubs, the antenna is asymmetric along the  $xz$ -plane, which gives a slightly asymmetrical radiation pattern in the  $E$ -plane pattern.

Backed by the reflector, the slot antenna radiates in broadside direction instead of bidirectional radiation. The front-to-back ratio is mainly controlled by the size of the backed reflector and a better front-to-back ratio is obtained with a larger reflector. Thus, this antenna configuration is a good candidate for a wall-mounted antenna, where the wall acts as a large ground plane. In addition, the beamwidths of both  $E$ -plane and  $H$ -plane patterns decreased as the resonant frequency increases. This is because the effective size of the antenna is increasing with frequency. The simulated  $H$ -plane beamwidths vary from  $64^\circ$  at 3 GHz to  $48^\circ$  at 9 GHz. The cross-polarization level in the  $E$ -plane is 20 dB lower than the co-polarization level which is due mainly to the symmetrical structure of the antenna. However, as shown in Figure 5, the cross-polarization level in the  $H$ -plane is relatively high and varies from 10 dB to 5 dB lower than the co-polarization level across the matching band.

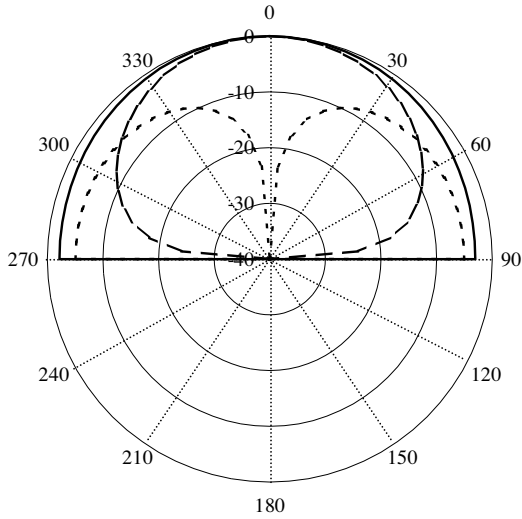
### 3. COPLANAR WAVEGUIDE (CPW) FED SLOT ANTENNA WITH U-SHAPED TUNING STUB

#### 3.1. Antenna Structures

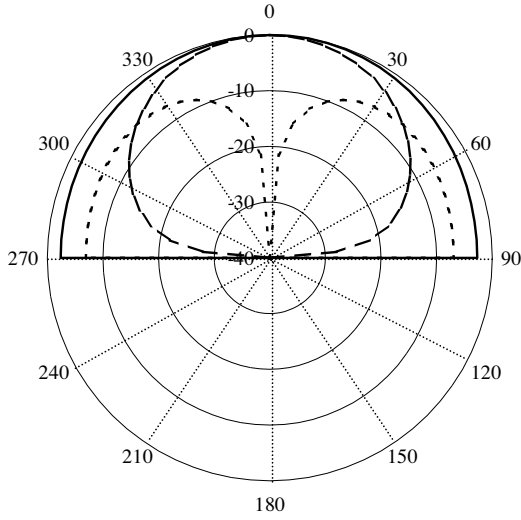
Figure 6 shows the proposed CPW fed slot antenna with a U-shaped tuning stub, backed by a reflector to minimize backward radiation. Unlike the microstrip line fed structure, the CPW fed antenna only needs a single conducting layer for fabrication, thus simplifying the fabrication process and avoiding the alignment problem introduced in the two layer microstrip line fed slot antenna. The size of the slot has a length  $L = 10.7 \text{ mm}$  ( $0.49\lambda_0$ ) and width  $W = 15.6 \text{ mm}$  ( $0.72\lambda_0$ ), where  $\lambda_0$  is the free space wavelength at the center frequency 13.8 GHz. A  $50\Omega$  characteristics impedance CPW is designed on a dielectric substrate with dielectric constant  $\epsilon_r = 3.38$  and thickness  $t = 0.813 \text{ mm}$ . The CPW has a center conductor width of 1.88 mm and the slot is 0.125 mm wide. The U-shaped tuning stub is employed for wideband performance. It has a total width of  $W_{stub} = 7 \text{ mm}$  and length  $L_{stub} = 4.6 \text{ mm}$ . The CPW transmission line is 44 mm long, which is used to gate the discontinuity of the SMA connector out of the measured results in the time domain measurement. A reflector of



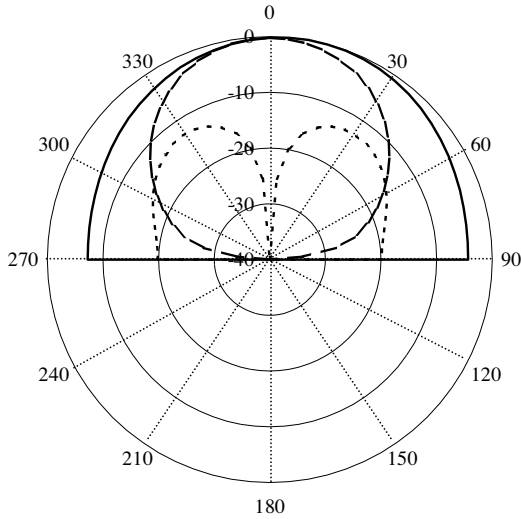
(a) 3 GHz



(b) 5 GHz



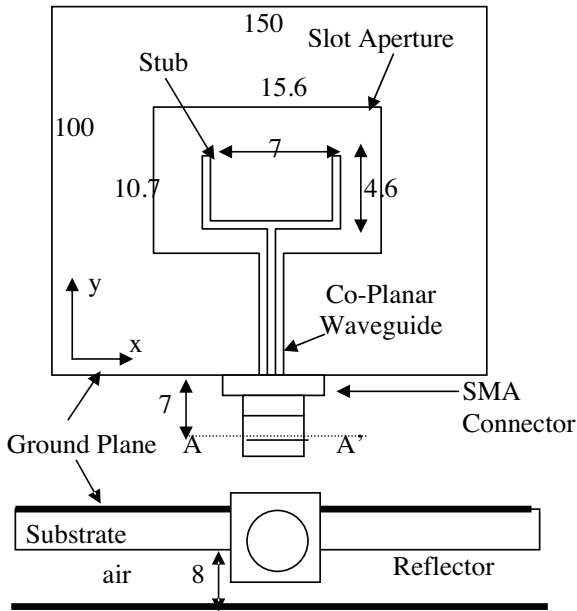
(c) 7 GHz



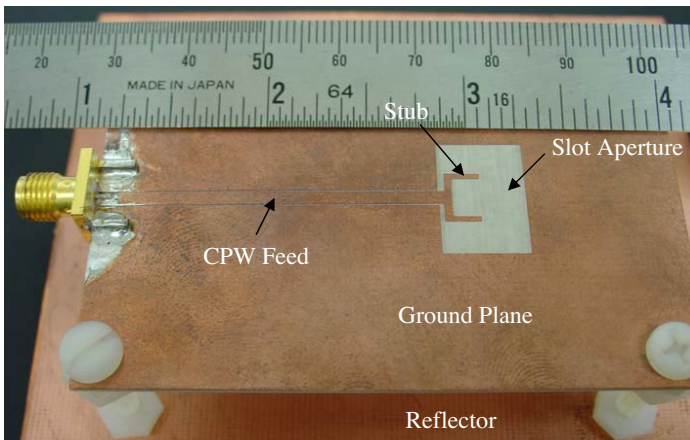
(d) 9 GHz

**Figure 5.** Simulated radiation pattern when  $d = 8$  mm (10 dB/Div)  
 — E-Co, — E-X, ..... H-Cc, - - - - H-X.





**Figure 6a.** Geometry of the CPW fed slot antenna with U-shaped tuning stub and reflector.



**Figure 6b.** Photograph of the antenna.

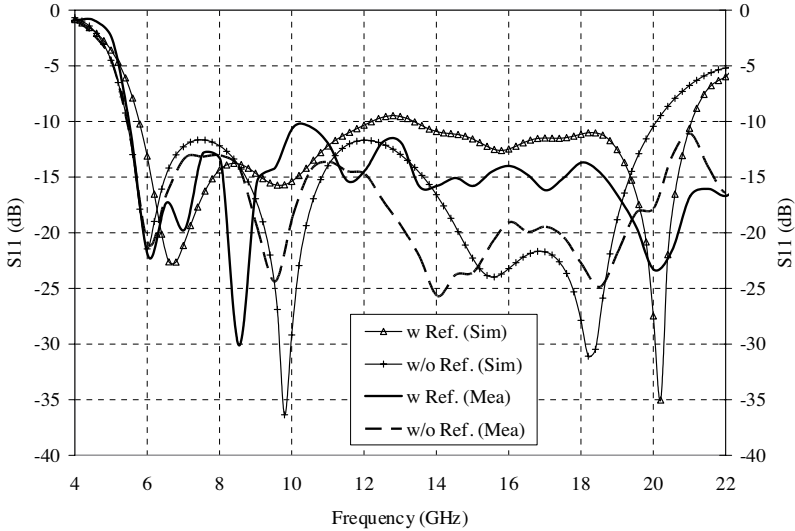
size  $100 \text{ mm} \times 100 \text{ mm}$  is placed 6 mm below the dielectric substrate. Geometrical detail including dimensions is shown in Figure 6a, and a photograph of the assembled antenna is given in Figure 6b.

### 3.2. Results and Discussions

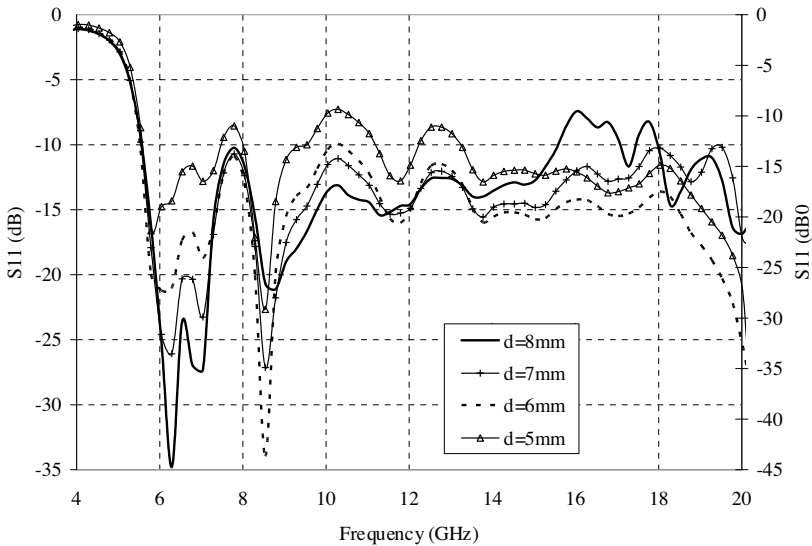
The simulated and the measured return loss of the CPW fed slot antennas with and without the reflector are presented in Figure 7. Both simulation and measurement results show good agreement. Without the reflector, the frequency range of the simulation and measurement results for which magnitude of  $S_{11} < -10 \text{ dB}$  are from 5.4 GHz to 20.1 GHz (center at 12.8 GHz) and from 5.4 GHz to 21 GHz (center at 13.2 GHz), respectively. The equivalent impedance bandwidths are 115% and 118%. With the reflector, the resonant frequency ranges are from 5.8 GHz to 21.1 GHz (center at 13.5 GHz) and from 5.5 GHz to 22 GHz (center at 13.8 GHz), respectively. The corresponding impedance bandwidths are 114% and 120%. This shows that a reflector can easily control the back radiation of the CPW fed slot antenna without affecting the matching of the slot antenna. Figure 8 shows the measured return loss of the CPW fed slot antenna with the reflector situated at different distances  $d$ . Trends similar to those observed for the microstrip line fed antenna are also observed. In these examples, the return loss of the antenna decreases as the reflector is positioned closer to the slot antenna making matching worse.

In Figure 9a and Figure 9b, the measured radiation pattern of the CPW fed slot antenna is shown with and without the reflector at 10 GHz, respectively. Furthermore, radiation patterns of the slot antenna with and without reflector simulated for 5 GHz, 10 GHz, 15 GHz and 20 GHz are shown in Figure 10 and Figure 11, respectively. From Figure 9, it can be seen that the slot antenna radiates bi-directionally with equal power. However, the use of the reflector reduces the back radiation of the slot antenna by 18 dB as shown in Figure 9b. The radiation from the CPW fed results in the radiation pattern differing from the case with the microstrip line fed. In addition, it is noted that since the antenna structure is symmetrical along the  $yz$ -plane, the cross-polarization level in the  $E$ -plane is 20 dB lower than the co-polarization level, with and without the reflector. Also, similar to the microstrip line fed, the cross-polarization level is relatively high in the  $H$ -plane and varies across the matching band. Figure 12 shows the simulated gain of the CPW fed slot antenna with and without reflector. The gain varies with the distance of the reflector as shown in Figure 12.

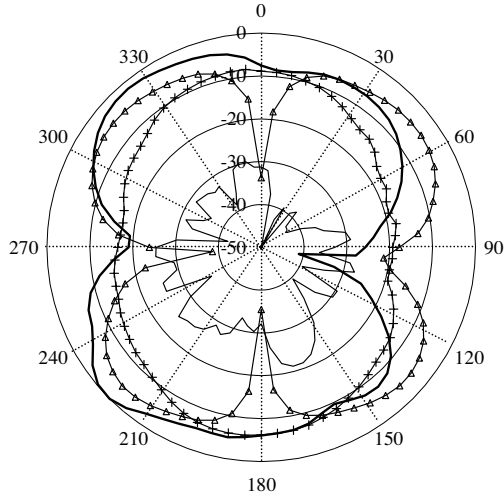
Comparisons of the simulated return loss obtained by using 3 different commercially available dielectric substrates, (i)  $\epsilon_r = 3.38$ ,  $t = 0.813 \text{ mm}$ ; (ii)  $\epsilon_r = 3.38$ ,  $t = 0.406 \text{ mm}$ ; and (iii)  $\epsilon_r = 2.4$ ,  $t =$



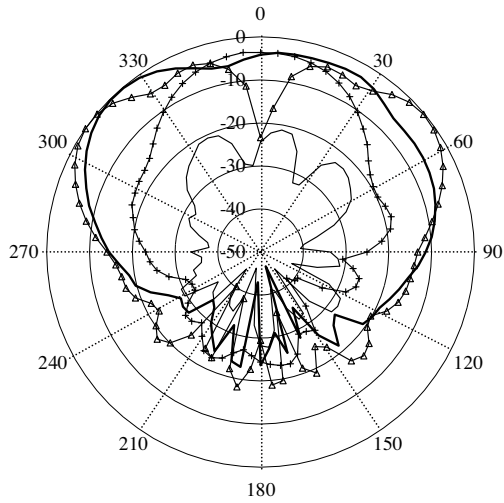
**Figure 7.** Measured and simulated return loss of the CPW fed slot antenna with and without reflector — — without reflector (measurement), + + without reflector (simulation), — — with reflector (measurement), -△- with reflector (simulation).



**Figure 8.** Measured return loss of the CPW fed slot antenna backed with reflector -△-  $d = 5$  mm, .....  $d = 6$  mm, + +  $d = 7$  mm, — —  $d = 8$  mm.

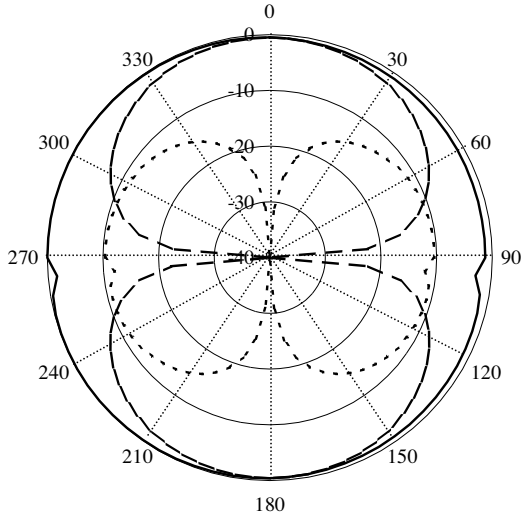


(a) without reflector

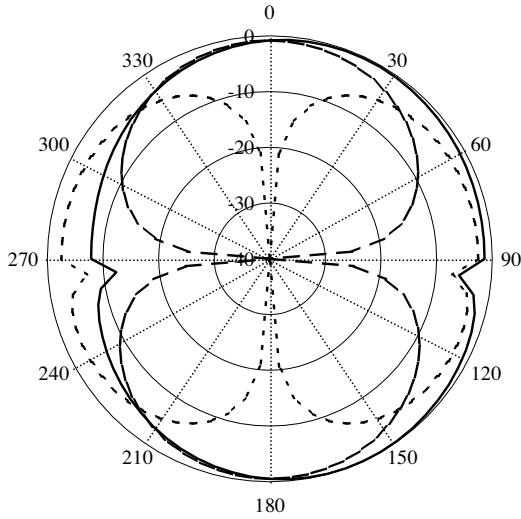


(b) with reflector

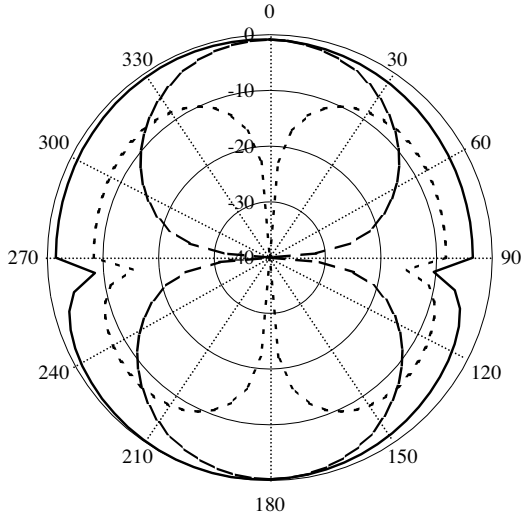
**Figure 9.** Measured radiation pattern at 10 GHz (10 dB/Div) — E-Co, — E-X, + H-Co,  $\triangle$  H-X.



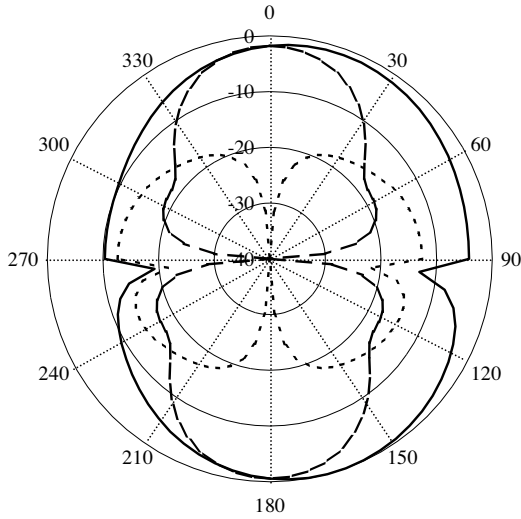
(a) 5 GHz



(b) 10 GHz

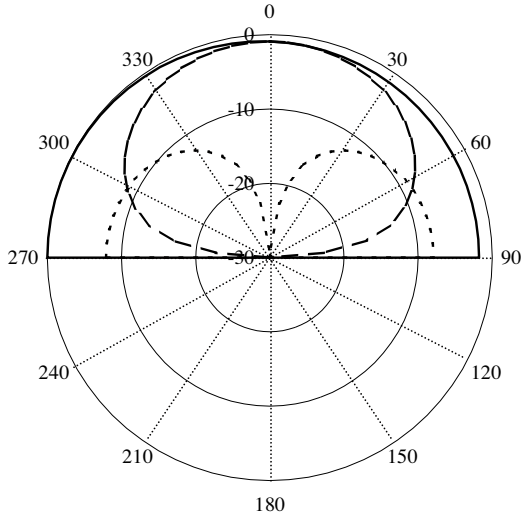


(c) 15 GHz

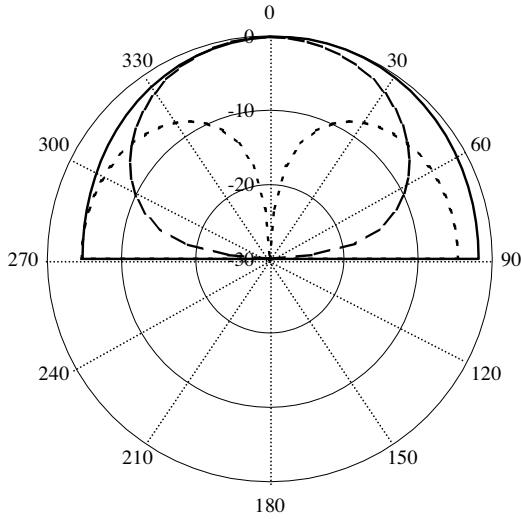


(d) 20 GHz

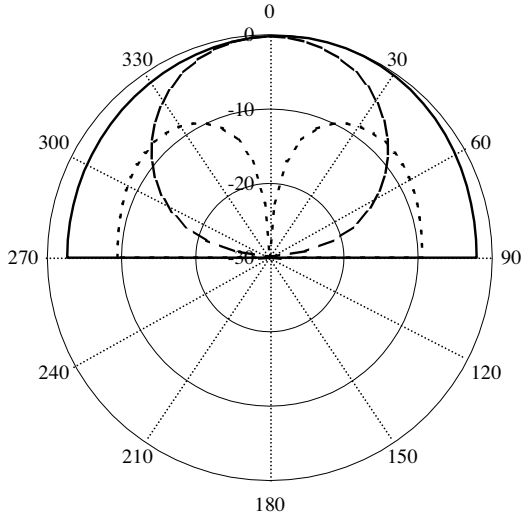
**Figure 10.** Simulated radiation pattern without reflector (10 dB/Div)  
 — E-Co, - - H-Co, ..... H-X.



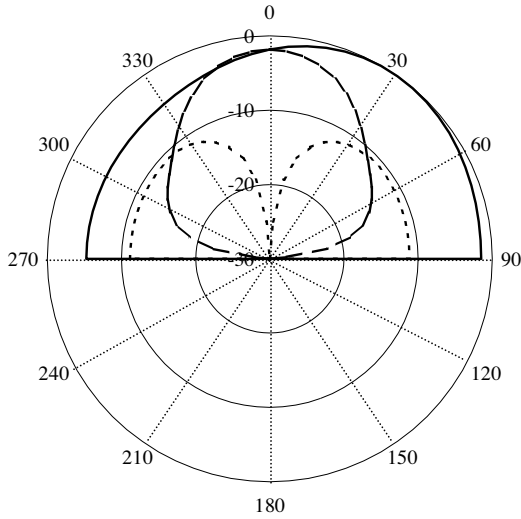
(a) 5 GHz



(b) 10 GHz



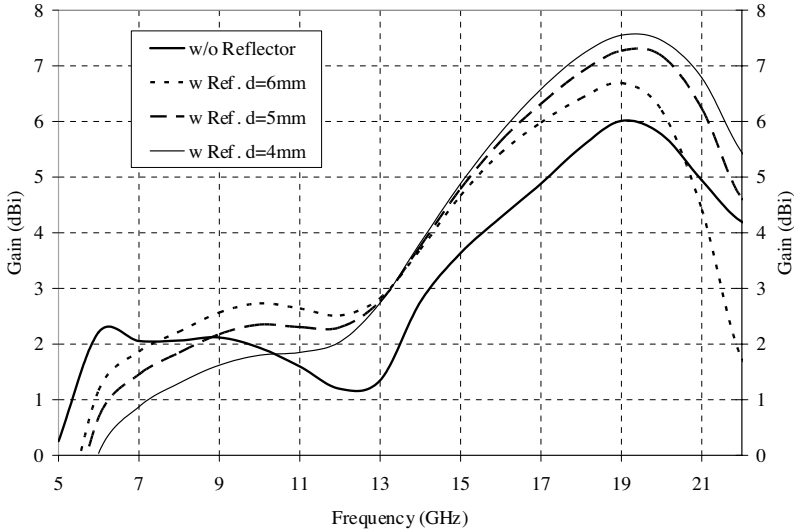
(c) 15 GHz



(d) 20 GHz

**Figure 11.** Simulated radiation pattern with reflector (10 dB/Div)  
 — E-Co, - - H-Co, ..... H-X.

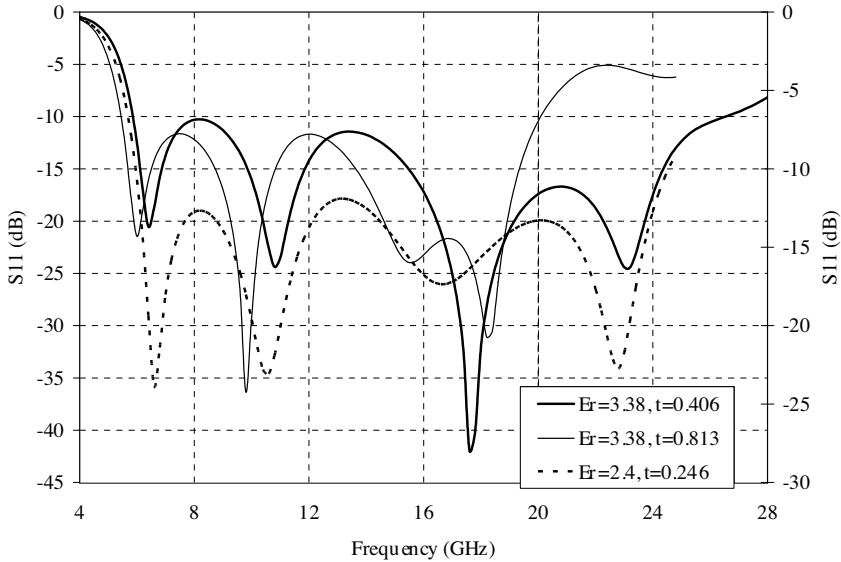




**Figure 12.** Simulated gains of the CPW-fed slot antennas **—** without reflector, **—** with reflector ( $d = 4$  mm), **- -** with reflector ( $d = 5$  mm), **.....** with reflector ( $d = 6$  mm).

0.246 mm are presented in Figure 13. The results for cases (i) and (ii) indicate that the impedance bandwidth increases with thinner dielectric substrates. From these results, the simulated impedance bandwidths are 114% and 130% when the thicknesses are 0.813 mm and 0.406 mm, respectively. In effect, reducing the substrate thickness is equivalent to reducing the effective permittivity of the dielectric substrate. Therefore, a lower Q-factor and a wider bandwidth are obtained. Case (iii) corresponds to very thin dielectric substrate with thickness  $t = 0.246$  mm and dielectric constant  $\epsilon_r = 2.4$ . This antenna configuration gives an impedance bandwidth of 123%. However, one problem associated with very thin dielectric substrate is that the width of the  $50\Omega$  CPW slot is very narrow, less than 0.1 mm, which is difficult to fabricate accurately.

Both the microstrip line and the CPW excitation give ultra-wideband performance with more than 100% impedance bandwidth and stable broadside radiation patterns across the matching band. In comparison, the CPW fed slot antenna has more advantages than the microstrip line fed structure. Wider bandwidth is achieved by CPW feed, and this antenna geometry eliminates the alignment error introduced in the two layer fabrication of the microstrip line fed structures.



**Figure 13.** Simulated return loss with different dielectric substrate —  $\varepsilon_r = 3.38$ ,  $t = 0.406$  mm, —  $\varepsilon_r = 3.38$ ,  $t = 0.813$  mm.

#### 4. CONCLUSIONS

In this study, unidirectional wideband rectangular slot antennas were designed with an impedance bandwidth of more than 100%. Two different excitation mechanisms using a U-shaped tuning stub are proposed and investigated. The microstrip line fed rectangular slot with U-shaped tuning stub and backed with reflector achieved an impedance bandwidth of 110%. When the rectangular slot was excited by a coplanar waveguide feed and backed by a reflector, an impedance bandwidth of 120% was achieved. Both structures produced broadside radiation patterns across the matching bandwidth.

#### ACKNOWLEDGMENT

This work was partially supported by the National Science Foundation under Grant no. ECS-0220218

#### REFERENCES

1. Yoshimura, Y., "A microstrip line slot antenna," *IEEE Trans. Microwave Theory and Tech.*, 760–762, Nov. 1972.

2. Kahrizi, M., T. K. Sarkar, and Z. A. Maricevic, "Analysis of a wide radiating slot in the ground plane of a microstrip line," *IEEE Trans. Microwave Theory and Tech.*, Vol. 41, No. 1, 29–37, January 1993.
3. Shum, S. M., K. F. Tong, X. Zhang, and K. M. Luk, "FDTD modeling of microstrip-line-fed wide-slot antenna," *Microwave Opt. Technol. Lett.*, Vol. 10, 118–120, 1995.
4. Hong, C. S., "Small annular slot antenna with capacitor loading," *Electron. Lett.*, Vol. 36, No. 2, 110–111, January 2000.
5. Lin, S. Y. and K. L. Wong, "A dual-frequency microstrip-line-fed printed slot antenna," *Microwave Opt. Technol. Lett.*, Vol. 28, No. 6, 373–375, March 2001.
6. Ooi, B. L., K. Chew, and M. S. Leong, "Log-periodic slot antenna array," *Microwave Opt. Technol. Lett.*, Vol. 25, No. 1, 24–27, April 2000.
7. Rao, P. H., "Feed effects on the dimensions of wideband slot antennas," *Microwave and Opt. Technol. Lett.*, Vol. 40, No. 1, January 2004.
8. Rao, P. H., V. F. Fusco, and R. Cahill, "Linearly polarized radial-stub-fed high-performance wideband slot antenna," *Electron. Lett.*, Vol. 37, 335–337, 2001.
9. Jang, Y. W., "A broadband cross-shaped microstripline-fed no-offset ring slot antenna," *Microwave Opt. Technol. Lett.*, Vol. 36, No. 1, 61–63, January 2003.
10. Sze, J. Y. and K. L. Wong, "Bandwidth enhancement of a microstrip-line-fed printed wide-slot antenna," *IEEE Trans. Antennas and Propagat.*, Vol. 49, No. 7, 1020–1024, July 2001.
11. Jang, Y. W., "Broadband cross-shaped microstrip-fed slot antenna," *Electron. Lett.*, Vol. 36, No. 25, 2056–2057, December 2000.
12. Qing, X., M. Y. W. Chia, and X. Wu, "Wide-slot antenna for UWB applications," *2003 IEEE AP-S Int. Symp. Dig.*, 834–837, 2003.
13. Tzeremes, G., T. S. Liao, P. K. L. Yu, and C. G. Christodoulou, "Computation of equivalent circuit models of optically driven CPW-fed slot antennas for wireless communications," *IEEE Antennas and Wireless Propagat., Lett.*, Vol. 2, 140–142, 2003.
14. Huang, J. F. and C. W. Kuo, "CPW-fed slot antenna with CPW tuning stub loading," *Microwave Opt. Technol. Lett.*, Vol. 19, No. 4, 257–258, November 1998.
15. Allen, C. M., A. A. Eldek, A. Z. Elsherbeni, and C. E. Smith,

- “A wideband coplanar-waveguide-fed multi-slot antenna for radar applications,” *Microwave Opt. Technol. Lett.*, Vol. 39, No. 1, 24–27, October 2003.
16. Bhobe, A. U., C. L. Holloway, M. Piket-May, and R. Hall, “Coplanar waveguide fed wideband slot antenna,” *Electron. Lett.*, Vol. 36, No. 16, 1340–1342, August 2000.
  17. Chiou, J. Y., J. Y. Sze, and K. L. Wong, “A broad-band CPW-fed strip-loaded square slot antenna,” *IEEE Trans. Antennas and Propagat.*, Vol. 51, No. 4, 719–721, April 2003.
  18. Chen, H. D., “Broadband CPW-fed square slot antennas with a widened tuning stub,” *IEEE Trans. Antennas and Propagat.*, Vol. 51, No. 8, 1982–1985, August 2003.
  19. IE3D 10.1, Zeland Software Inc., Fremont, CA., USA.
  20. Fidelity 4.2, Zeland Software Inc., Fremont, CA., USA.