

Microwave Measurements Part I: Linear Measurements

Original

Microwave Measurements Part I: Linear Measurements / Pirola, Marco; Teppati, Valeria; Camarchia, Vittorio. - In: IEEE INSTRUMENTATION & MEASUREMENT MAGAZINE. - ISSN 1094-6969. - STAMPA. - 10:2(2007), pp. 14-19.
[10.1109/MIM.2007.364959]

Availability:

This version is available at: 11583/1644805 since:

Publisher:

IEEE piscataway

Published

DOI:10.1109/MIM.2007.364959

Terms of use:

openAccess

This article is made available under terms and conditions as specified in the corresponding bibliographic description in the repository

Publisher copyright

(Article begins on next page)



Marco Pirola, Valeria Teppati, and Vittorio Camarchia

Microwave Measurements

Part I : Linear Measurements

By convention, radio frequency (RF) and microwave frequencies range between 30 MHz and 300 GHz. Conversely, this means their wavelengths range between 10 m and 1 mm. Intense research in radar development during World War II extended the RF spectrum beyond the usual applications in radio communications. The use of shorter wavelengths resulted in laboratory equipment with proportionally smaller dimensions to generate, convey, transmit, and detect higher-frequency signals. Wavelengths shorter than 1 mm require equipment too small to be realized.

Voltage, current, and impedance concepts lose their conventional meanings when the operating wavelength is approximately equal to the dimensions of the structures under test. The behavior of propagating electromagnetic waves must then be analyzed in terms of electric and magnetic field. Unfortunately, no simple and direct way exists to measure these quantities, so we must resort to indirect methods.

Until the 1960s, microwave measurements were carried out by instruments such as microwave cavities (for wavelength measurements), power sensors (for power measurements), and standing-wave-ratio meters (slotted lines) and waveguide bridges (for impedance measurement). All these techniques were scalar measurements combined with precision mechanical measurements (for example, probe displacement in a slotted line). Vector quantities were inferred by making different scalar measurements along a slotted line, e.g., impedance measurements.

In the 1960s, another type of microwave power-measuring instrument—the spectrum analyzer—was introduced based on the principle of superheterodyne conversion. This instrument exploits the principle of converting each microwave signal frequency component to an intermediate frequency (IF) where the signal can be more easily detected.

During the same time, the first scattering parameter measurements were performed with the most popular microwave instrument—the vector network analyzer (VNA). This instrument uses subsampling or mixing techniques. It downconverts the microwave signals to an IF frequency, where they can be detected in both magnitude and phase. Following the first scalar versions, the instrument evolved into vector measurements with faster acquisition times and higher dynamic ranges (up to 130 dB).

In the following sections, we briefly review the concept and need for measurements of scattering parameters. We also describe the two key instruments for microwave measurements: VNAs and spectrum analyzers.

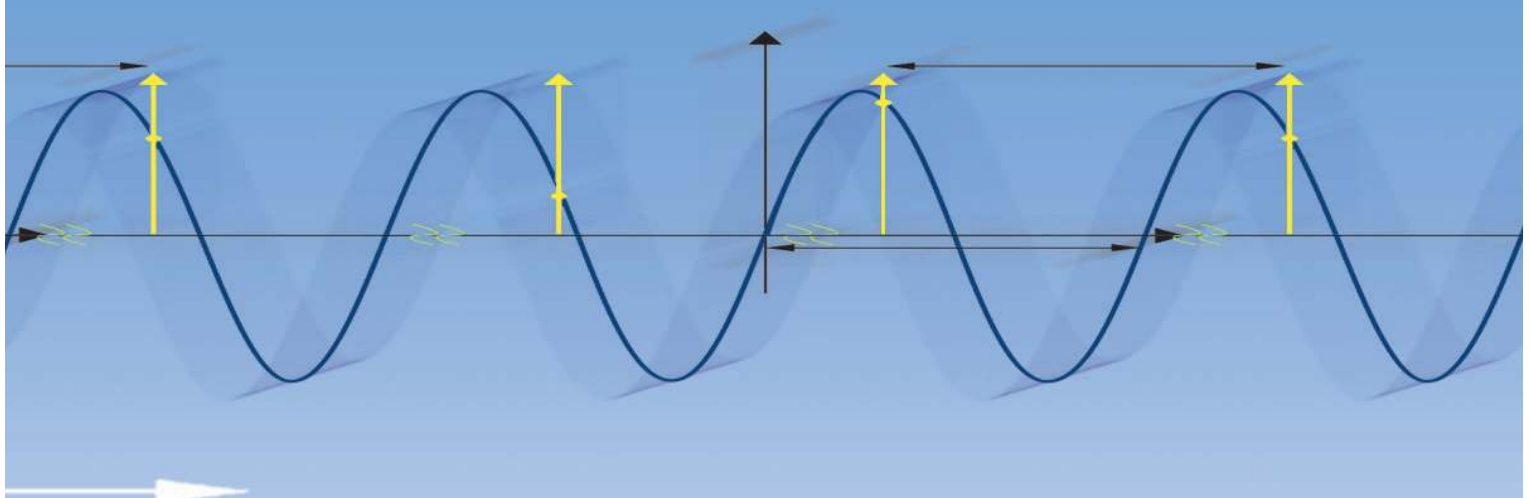

Scattering Parameters

Microwave circuits are usually considered and investigated as system blocks in which only the electric interactions with the external environment (through their ports) are taken into account. In fact, microwave circuits are often distributed, and thus the classical voltage and current concepts are not always applicable. The system port positions (the so-called reference planes of the characterization) must be exactly defined, so that the port concept is always lumped and therefore the voltages and currents associated with them can be unambiguously defined. The impedance, or admittance matrix representations, commonly adopted at low frequency are, at least theoretically, suitable also at RF. The experimental setup requirements, however, are incompatible with the practical constraints. The elements of these matrices are usually identified through voltage and current vector measurements versus frequency over the band of interest once the system ports are terminated consistently with the chosen representation, i.e., short or open circuits.

The classical low-frequency identification techniques are impracticable at RF, not only because trustworthy broadband terminations, either short or open, are difficult to fabricate, but because highly reflective loads (as are shorts and opens) can be extremely dangerous to the integrity of active RF devices during their characterization. In fact, they can get damaged or—at best—start oscillating, thus invalidating the experimental results. These problems have been overcome by introducing the wave quantities at each system port, linked to the voltage and current port according to the following expressions and to the voltage and current conventions adopted in Figure 1.

$$\begin{cases} a = \frac{1}{2} \left(\frac{V}{\sqrt{R_0}} + I\sqrt{R_0} \right) \\ b = \frac{1}{2} \left(\frac{V}{\sqrt{R_0}} - I\sqrt{R_0} \right) \end{cases} \quad \begin{cases} V = \sqrt{R_0}(a + b) \\ I = \frac{1}{\sqrt{R_0}}(a - b) \end{cases}$$

where V and I are the voltage and current port, a and b are the wave quantities, and R_0 is a normalization factor having the unit Ω [1]. These equations stand only for the real and positive reference impedance, R_0 . In [2], a more complete formulation that takes into account the complex reference impedances is given. It is important to note that for a scattering representation to be complete, the R_0 normalization factor must always be defined and made explicit; historically, the default value of 50Ω has been adopted worldwide.

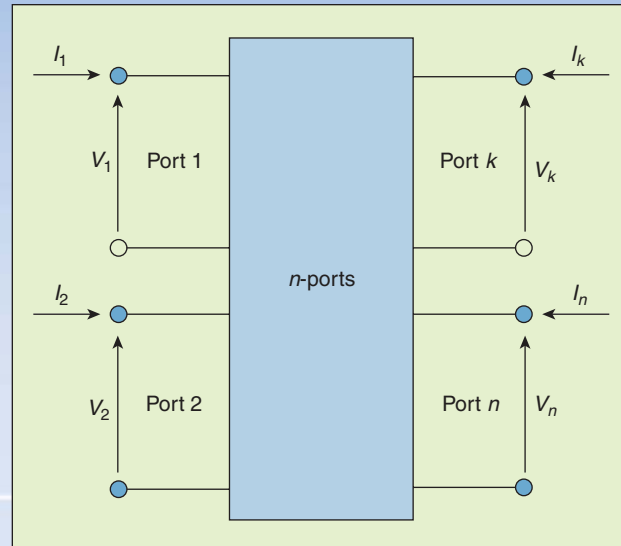

Fig. 1. System port voltage and current conventions adopted in S-Parameters calculations.

Wave definitions have been borrowed from transmission line theory; however, they can handle more than distributed systems. In fact, the expressions defining them do not need any further physical interpretation and can be seen as equivalent transformations of coordinates between two reference systems.

The a and b waves become the variables of the new representation. They define a new set of linear parameters called the scattering parameters. These parameters relate the vector of the a port waves to the corresponding b port waves. The scattering parameter identification can be carried out by terminating the system ports on resistances rather than on short or open loads. In fact, to null the a wave at a generic port, as required for the experimental identification of the elements of the scattering matrix, the condition $V/I = -R_0$ must be enforced, or, in other words, the port must be terminated on an R_0 resistance.

This reduces the risk of instability during the characterization of active devices and poses less critical technological problems for the realization of the port termination standards, since precise broadband resistances are far easier to fabricate than shorts or opens.

The VNA

The VNA is now a fundamental test-set instrument for all microwave laboratories. It appeared on the market in the

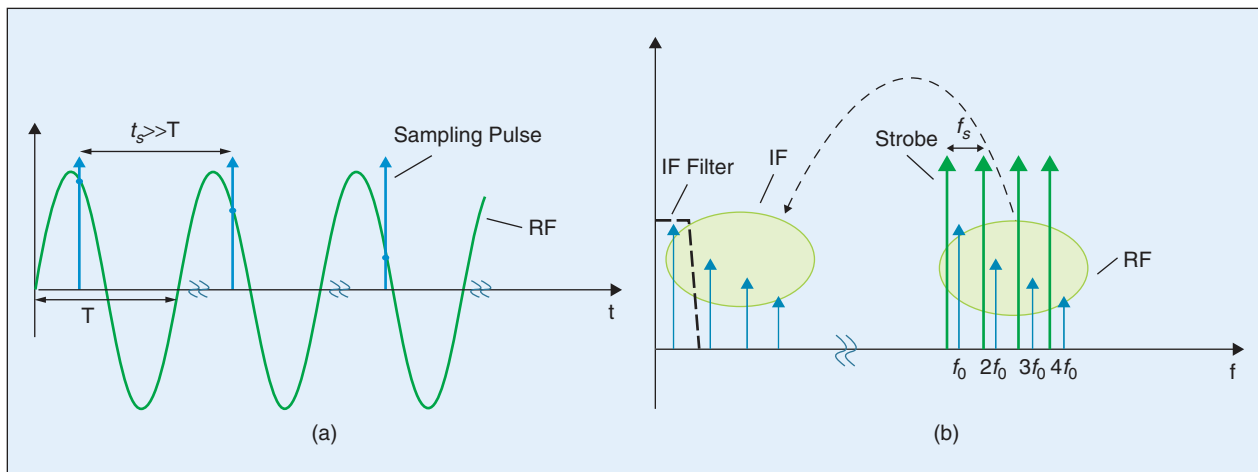

Fig. 2. Subsampling of periodic-signal in (a) time domain and (b) frequency domain representations.

late 1960s [3]–[6] and can measure the magnitude and phase (with respect to a reference) of a microwave signal. Direct measurements of magnitude and phase for microwaves are extremely challenging; they are carried out on a replica of the incoming signal, downconverted to IF. The basic principle of VNAs relies on the IF simultaneous and synchronous conversion of a test signal and a reference signal using identical samplers/mixers, so that the phase relationship and amplitude ratio is maintained before and after the IF frequency conversion, where ordinary vector voltmeters can be used.

The sampler downconversion technique was the first to be adopted [5]. It is a subsampling procedure (below the Nyquist frequency) that employs a strobe signal formed by a series of very narrow pulses (Figure 2).

On the other hand, mixer-based techniques based on the heterodyne concept have rapidly gained the majority of the market. Improvements in mixer fabrication technology and in the availability of relatively low-cost and repeatable RF downconversion units have made this possible.

To complete the VNA basic description, the RF vector voltmeter must be inserted into a more complex scheme that separates the forward and reverse travelling

wave contributions and measures scattering parameters at the reference plane. To this end, a VNA uses high-directivity, low-loss broadband directional couplers. Figure 3 shows a block diagram of a two-port VNA. Here the classical VNA architecture has the following functional blocks:

- ▶ IF detection and phase lock
- ▶ analog-to-digital conversion
- ▶ data processing and display
- ▶ a microwave synthesized source for the signal generation
- ▶ a dual reflectometer test-set to separate and select incident and reflected waves at the device under test (DUT) ports (directional couplers or directional bridges) [6].

Typical frequency ranges are from 30 kHz to 100 MHz for lower frequencies, and 6, 18, 40, 65, or 110 GHz for the upper frequencies. Modern mixed-based instruments allow very accurate measurements, with more than 120 dB dynamic range and very narrow IF bandwidths (a few hertz).

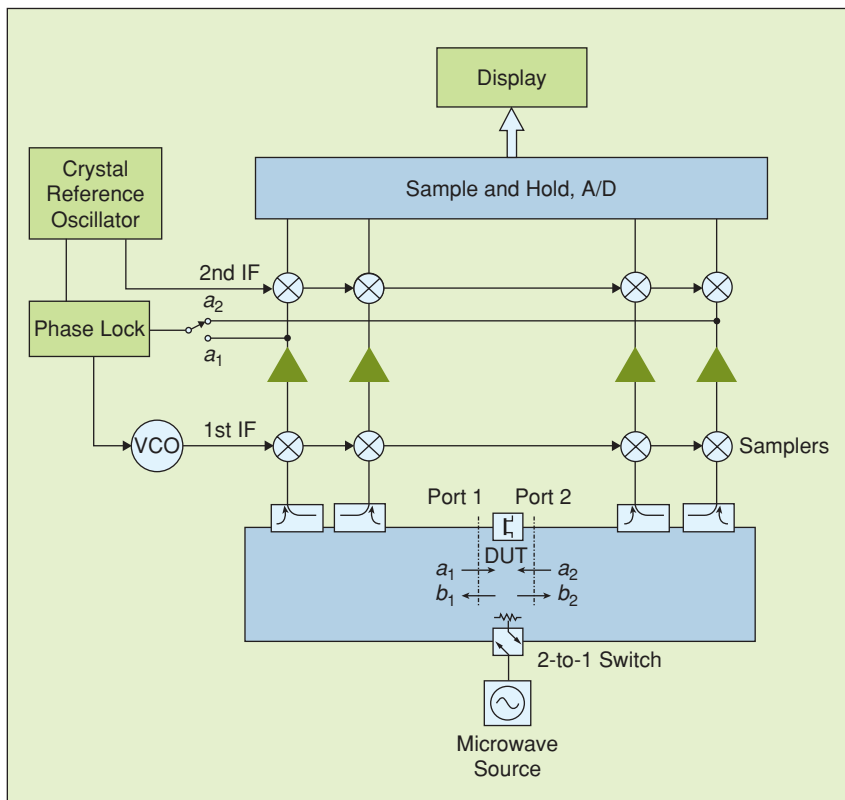

Fig. 3. Functional block scheme of a double conversion, two-port VNA.

Calibration of Network Analyzer-Based Systems

VNA measurements are affected by systematic errors, drifts and random uncertainties, mainly due to noise and connector repeatability effects. Systematic errors such as directional couplers imperfections, mismatch errors with adapters and cables, cross-talk, coaxial configuration switches losses, and mismatch overwhelm all others by at least an order of magnitude, forcing the mandatory use of an appropriate calibration technique.

Typically, all calibration procedures consider the actual VNA as an ideal system without systematic error (a perfect linear receiver) followed by a linear network, called an error-box, which models the combined influence of the systematic errors as shown in Figure 4.

Calibration solutions differ in how they handle identification of error-box parameters. In the following, we will consider classical two-port VNAs. Increasing the number of VNA ports requires more complex calibration procedures. The basic concept is to extract the error-box parameters [7]. Multipoint measurements have recently gained interest because of the possible applications to differential parameter measurements [8].

The error-box is assumed to be a linear network (the relationships among raw and corrected parameters are linear). For accurate measurements of highly isolated devices, you must check for proper power levels at each port to quantify the amount of nonlinearity errors [9].

The error-box parameters are calculated by measurements of a set of precise components modelled through electromagnetic simulation, or through low-frequency measurement of devices with scaled dimensions, called standards. Comparison of the modelled responses with the actu-

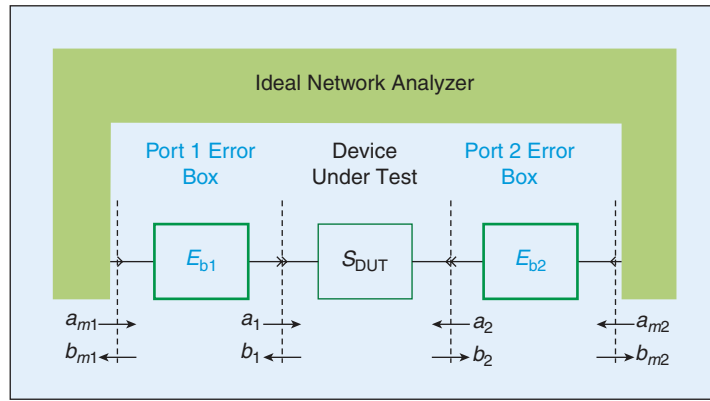

Fig. 4. Error-box model for VNA error correction.

al standard measurements identifies the error-box parameters. The measurement accuracy after the calibration procedure depends on the number and type of standards applied during the calibration, the degree of their knowledge, and the quality of the interconnections. Also, the final reference impedance of the system depends on the calibration type and on the standards implied during the calibration.

Different procedures can be based on fully known standards, such as short open load thru (SOLT), or on the so-called self-calibrations, such as thru reflect line (TRL), line reflect match (LRM), and short open load reciprocal (SOLR) [10]. Table 1 shows the important characteristics of these calibration techniques along with a short description of the main advantages and constraints of the various approaches.

Accuracy improvements for calibrations that rely on standard definitions like SOLT can be obtained by refining electrical models of shorts, opens, and loads [12]. An alternative to electrical models is tabular data, which can be used as a standard definition, e.g. when standards are measured in a certified laboratory with TRL-calibrated VNAs [13].

Table 1. Description of the most widely adopted calibration techniques for VNAs.

Calibration Type	SOLT	TRL	LRM
Required standards	Short open load thru	Thru reflection line	Line reflect match
Available Environment	Waveguide coaxial on-wafer	Coaxial on-wafer	Coaxial on-wafer
Description	Most widely adopted for two-port VNA. Standards available in every environment.	Does not require a complete set of fully known calibration standards.	Mainly for on-wafer measurements where the probe movement is difficult.
Major Constraints	Perfect knowledge of all standards needed. Large number of measurements during calibration. Requires a direct port connection.	Only the knowledge of the line reference impedance is needed. Working bandwidth limited below the resonant frequency of the line where it is undistinguishable from the thru connection. Multiline methods can overcome this problem [11].	Fully known one-port matched load instead of the line of the TRL algorithm. Quality of the match standard is extremely important.

Spectrum Analyzer at Microwaves

Spectrum analysis is another popular measurement technique for microwaves. As their low-frequency counterparts, microwave frequency spectrum analyzers are generally based on super-heterodyne conversion, with some special expedients to extend operation at microwaves.

The classical principle of super-heterodyne conversion is shown in Figure 5. The signal generated by a voltage control oscillator (VCO), called the local oscillator (LO), is mixed with the signal under test, and converted into an IF. The VCO control signal is used to generate the frequency axis for the visualization, while IF signal amplitude is measured and visualized on the y -axis of the instrument.

With this approach, the extension of the band to the microwave range presents two problems. On one hand, the IF filter band [also called resolution bandwidth (RBW)], increases as IF increases to microwave values, thus reducing the instru-

**The VNA is now a
fundamental test-set
instrument for all
microwave laboratories.**

ment frequency resolution. On the other hand, VCOs at microwaves would not have the required high stability and accuracy.

The first issue is easily overcome with double (or multiple) conversion techniques as shown in Figure 6 [14]. The first IF is higher, thus filtered with a relatively large band

filter, while the second IF, much lower than the first, has a very narrow band filter, thus increasing the instrument final frequency resolution.

The second issue, instead, is generally approached with VCO harmonic mixing. With a nonlinear element, harmonics of the VCO signal are generated and mixed with the signal under test.

The condition realized by the mixer is then $f_s = n f_{LO} \pm f_{IF}$ where f_{IF} is frequency of the signal at the mixer IF output, f_{LO} is the VCO frequency, and f_s is the signal under test frequency component.

In this way, for each f_{LO} value, more than one f_s components of the signal under test are

converted to image frequencies. Moreover, for each frequency f_s to be analyzed, more than one f_{LO} values can be used (multiple response). An example with $f_{IF} = 2$ GHz and $f_{LO} = 2 - 4$ GHz is shown in Figure 7. The f_s characteristics are plotted as a function of f_{LO} for $n = 1, 2, 3$.

To overcome both the described issues, a preselection, yttrium-iron-garnet (YIG)-tuned filter is placed at the input. It properly filters the input signal and its effect is to eliminate both images and multiple responses.

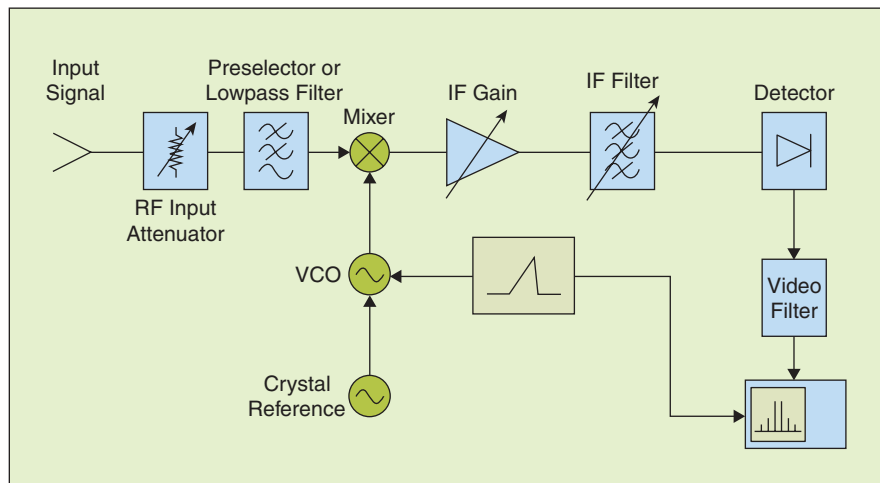

Fig. 5. Simplified block scheme of a super-heterodyne spectrum analyzer.

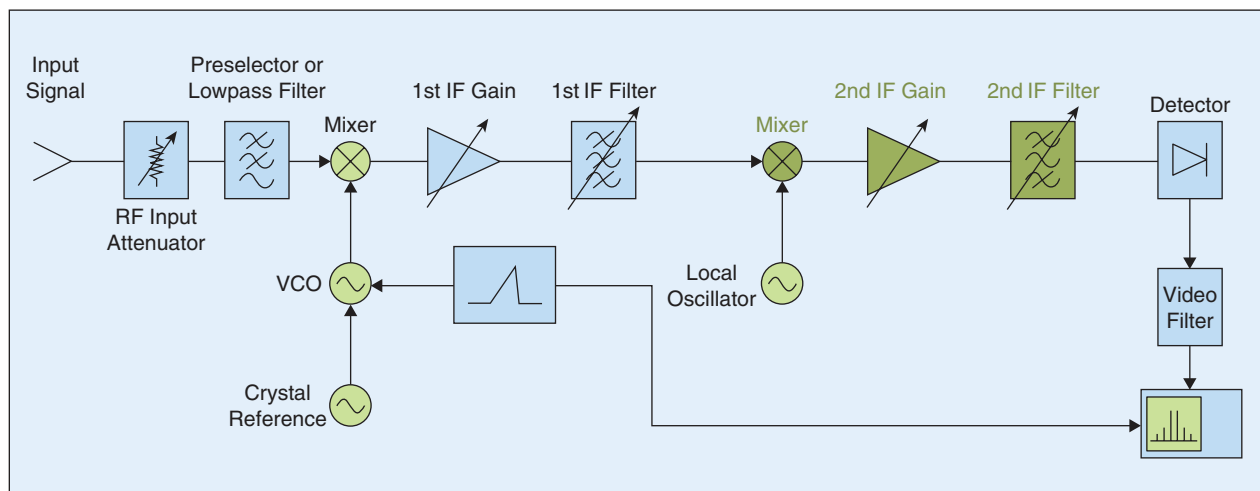

Fig. 6. Double IF conversion spectrum analyzer block scheme.

By properly tuning the filter, synchronously with the VCO sweep, a specific characteristic $f_s(f_{LO})$ is followed.

Conclusions

We have presented a short overview of the most important issues related to RF and microwave measurements. We introduced the scattering formalism and explained its effectiveness for high-frequency device characterization. We presented the principal features of two microwave instruments, the VNA and the spectrum analyser, and emphasized the elimination of systematic errors that are of crucial importance at high frequency.

Acknowledgments

Prof. Umberto Pisani and Prof. Andrea Ferrero are sincerely acknowledged. Research reported here was partially performed in the context of the networks of excellence "TARGET-Top Amplifier Research Groups in a European Team" contract No. IST-1-507893-NOE, www.target-net.org and "NEWCOM-Network of Excellence in Wireless COMMunication" contract No. IST-1-507325-NOE. The MIUR through PRIN 2005 FPGAN and the "KORRIGAN-Key Organization for Research on integrated circuits in GaN technology" projects are also acknowledged.

References

- [1] K. Kurokawa, "Power waves and scattering matrix," *IEEE Trans. Microwave Theory Tech.*, vol. MTT-13, no. 3, pp. 194–202, Mar. 1965.
- [2] R. Marks and D. Williams, "A general waveguide circuit theory," *J. Res. Nat. Inst. Stand. Technol.*, vol. 97, pp. 533–561, Sep. 1992.
- [3] R. Anderson and O. Dennison, "An advanced new network analyzer for sweep measuring amplitude and phase from 0.1 to 12.4 GHz," *Hewlett Packard J.*, vol. 18, pp. 2–9, Feb. 1967.
- [4] R.A. Hackborn, "An automatic network analyzer system," *Microwave J.*, vol. 11, pp. 45–52, May 1968.
- [5] D. Rytting and S. Sanders, "A system for automatic network analysis," *Hewlett Packard J.*, vol. 21, pp. 2–10, Feb. 1970.
- [6] *HP8510 Network Analyzer System Operating and Programming Manual*, Hewlett-Packard Co., Santa Rosa, CA, HP # 08510-90005, 1985.
- [7] A. Ferrero, U. Pisani, and K.J. Kerwin, "A new implementation of a multiport automatic network analyzer," *IEEE Trans. Microwave Theory Tech.*, vol. 40, no. 11, pp. 2078–2085, Nov. 1992.
- [8] A. Ferrero, M. Pirola, "Generalized mixed-mode S-parameters," *IEEE Trans. Microwave Theory Tech.*, vol. 54, no. 1, pp. 458–463, Jan. 2006.
- [9] *HP8510C Network Analyzer System Specification and Performance Verification Program Manual*, HP8510 Software Supplement, 1987.
- [10] A. Ferrero and U. Pisani, "Two-port network analyzer calibration using an unknown 'thru'," *IEEE Microwave Guided Wave Lett.*, vol. 2, no. 12, pp. 505–507, Dec. 1992.
- [11] R.B. Marks, "A multiline method of network analyzer calibration," *IEEE Trans. Microwave Theory Tech.*, vol. MTT-39, pp. 1205–1215, July 1991.
- [12] S. Padmanabhan, L. Dunleavy, J.E. Daniel, A. Rodriguez, and P.L. Kirby, "Broadband space conservative on-wafer network

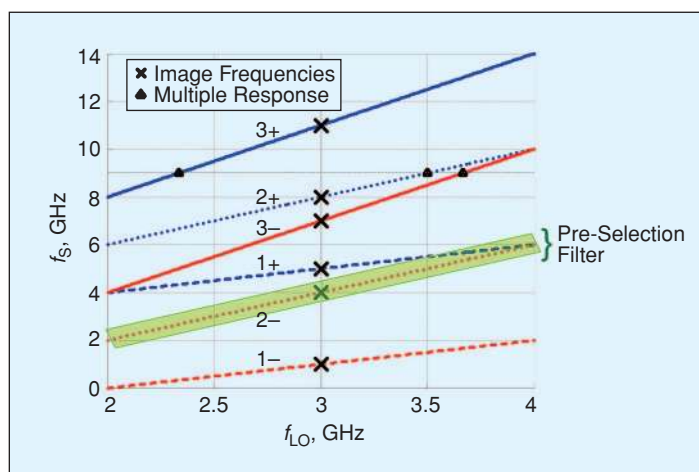

Fig. 7. Harmonic mixing for spectrum analyzer bandwidth extension.

analyzer calibrations with more complex load and thru models," *IEEE Trans. Microwave Theory Tech.*, vol. 54, no. 9, pp. 3583–3593, Sept. 2006.

- [13] Agilent Technologies, "Agilent electronic calibration (ECal) modules for vector network analyzers," *Agilent Technologies*, Santa Rosa, CA, 5963-3743E, 2003.
- [14] Agilent Technologies, "Spectrum Analysis Basics," Application Note 150, 5952-0292, 2000.

Marco Pirola (marco.pirola@polito.it) received the Laurea degree in electronic engineering and the Ph.D. from Politecnico di Torino, Italy, in 1987 and 1992, respectively. In 1992 and 1994, he was a visiting researcher at the Hewlett Packard Microwave Technology Division, Santa Rosa, California. Since 1992, he has been with the Electronic Department of Politecnico di Torino, first as researcher and, since 2000, as associate professor, where his research concerns the simulation, modeling, and measurements of microwave devices and systems.

Valeria Teppati received the degree in electronics engineering from Politecnico di Torino, Torino, Italy, in 1999 and the Ph.D. in electronic instrumentation in 2003. Since then, she has been a research and teaching assistant at Politecnico di Torino. Her research interests and activities include microwave devices design, linear and nonlinear measurements, calibration, and uncertainty.

Vittorio Camarchia received the Laurea degree and the Ph.D. in electronic engineering from the Politecnico di Torino, Turin, Italy, in 2000 and 2003, respectively. From 2001–2003, he was a visiting researcher with the ECE Department, Boston University, Massachusetts. In 2002, he received the Young Graduate Research Fellowship from the Gallium Arsenide Application Symposium Association. In February 2003, he joined the Dipartimento di Elettronica of the Politecnico di Torino. His research is focused on RF device modeling, simulation, and characterization, both linear and nonlinear.