

Date of publication xxxx 00, 0000, date of current version xxxx 00, 0000.

Digital Object Identifier 10.1109/ACCESS.2017.Doi Number

Mixed-Integer Distributed Ant Colony Multi-Objective Optimization of Single-Tuned Passive Harmonic Filter Parameters

Ahmed F. Zobaa, Senior Member, IEEE.

Brunel University London, Electronic and Computer Engineering Department, Uxbridge, UB8 3PH, Middlesex, United Kingdom

Corresponding author: Ahmed F. Zobaa (e-mail: azobaa@ieee.org).

ABSTRACT The extended ant colony known as Mixed Integer Distributed Ant Colony Optimization (MIDACO) is presented in this paper as a new application of solving multi-objective single-tuned passive filters design problems. This paper presents a new non-dominated solution for the optimization of four independent objective functions which are maximized power factor, minimized total harmonic voltage distortion, minimized total demand distortion and minimized investment cost of the filter. The global solution is achieved by maintaining the quality factor of the filter in a specified range, avoiding the harmonic resonance and maintaining the capacitor's capability limits within the standard limits. The attained parameters of the filter are used to weigh the performance of the system, and the robustness of the proposed algorithm is verified by comparing the results with three different highly competitive evolutionary techniques. Also, the proposed algorithm attains the Pareto front of the problem and tolerates the selection of its parameters to the most effective solution. The numerical results specify the comprehensive passive filter design through possible multi-objective approaches, and the improvements of multi-objective over single-objective optimization are also presented in this paper.

INDEX TERMS Power quality, harmonics, multi-objective optimization, ant colony optimization, passive filter.

I. NOMENCLATURE

X_L	Inductive reactance (ohms)	k_L	cost coefficients of inductor(\$/kvar)
X_C	Capacitive reactance (ohms)	k_R	cost coefficients of resistor (\$/kW)
R	Intrinsic resistance of inductance (ohms)	Q_C	Reactive power of capacitor (kvar)
P_L	Load power (W)	Q_L	Reactive power of inductor (kvar)
I_S	RMS source current (A)	P_R	Power of resistor (kW)
I_{SK}	K-th harmonic number of source current (A)	h	Harmonic order
I_L	Maximum current demand at PCC (A)	h_r	Harmonic order activating resonance
V_L	Load voltage in RMS (V)	U_i, N_i	Utopia and Nadir
V_{LK}	K-th harmonic number of Load voltage (V)	$d_i^j(x)$	Weighted distance
θ_K	K-th angle of load voltage (rad)	$D_j(x)$	Average distance
ϕ_K	K-th angle of line current (rad)	B_j	Balance parameter
k_C	cost coefficients of capacitor (\$/kvar)	$T_j(x)$	Objective function T
		R_{TH1}, X_{TH1}	Thevenin resistance and reactance (Ω)
		R_{L1}, X_{L1}	Load resistance and reactance (Ω)
		N_{pop}	Size of ants
		k	Number of kernel

Ω	Oracle parameter
V_C	Capacitor voltage in RMS (V)
V_{CP}	Peak capacitor voltage (V)
I_C	Capacitor current in RMS (A)
Q_C	Reactive power of capacitor (kvar)
QF	Quality factor
MAXEVAL	Maximum number of function evaluation.
PF	Power factor
$THDV$	Total harmonic voltage distortion
TDD	Minimum total demand distortion
$Cost$	Investment cost of the filter
PARETOMA	Maximum number of pareto point
X	
EPSILON	Precision pareto-dominance filter
BALANCE	Search effort on the part of the Pareto front

II. INTRODUCTION

The wide use of nonlinear loads in power systems results in increasing power quality problems such as harmonic pollution with consequences to power losses in electrical equipment, communication interference and even damage. Harmonic distortion causes unnecessary heat in the equipment, transformer overheating, nuisance tripping of circuit breakers and overstressing of power factor correction capacitors [1]. Therefore, it becomes a main concern to engineers to solve power quality issues, resonances problem and power system harmonic estimation to maintain the productivity and stability of industrial applications [2]–[4]. There are three types of filters that have been studied to eliminate the harmonic disturbances: passive [5]–[7], active [8]–[10] and hybrid [11], [12] power filters. The passive power filter (PPF) is the most favored method for harmonic mitigation when compared to the other techniques because of its design which is robust, simple and less expensive with almost maintenance-free operation. Furthermore, PPF also acts as reactive power compensation to the system, which helps improve the power factor and in the same time can reduce losses [13], [14]. Its nature has inspired many researchers to provide effective ways to solve problems including PPF designs where the optimization is classified as single-objective [15]–[18] and multi-objective [19]–[21]. This is not an easy task for engineers in designing of PPF because there are measurements, conditions and practical standards that must be carefully considered.

The goal of this paper is to find an optimal multi-objective single-tuned passive filter design using software which is motivated by behavior of ants proposed by Martin [22], [23]. There are various ant colony optimization (ACO) have been proposed to solve multi-objective problems [24], [25]. However, MIDACO uses the concept of utopia-nadir balance which is different from other traditional multi-objective methods where the algorithm focuses its search effort on a particular area of the Pareto front [26], [27].

Unlike the typical technique which alters the objectives using an appropriate scaling/weighting factor method, MIDACO automatically measures those values for its internal algorithmic procedures [27].

Some previous studies resolve the multi-objective problem by explaining each of the objectives individually [15]–[18], this paper works on non-dominated solutions for the optimization of four independent objective functions: 1) maximized power factor, 2) minimized total harmonic voltage distortion, 3) minimized total demand distortion and 4) minimized investment cost of the filter. The set of filters is designed considering that the values of the filter will avoid harmonic resonances, the filter is in the specified range of the quality factor, and as well as the values of the practical capacitor follow the IEEE standard [28]. The outcomes of multi-objective optimization over single-objective optimization are also discussed in this paper. Finally, the proposed methods are compared with three other optimizers in power quality areas which are genetic algorithm (GA), Non-dominated sorting Genetic Algorithm (NSGA-II) and Multi Objective Particle Swarm Optimization (MOPSO). The comparisons of performances between all methods are evaluated, and the robustness of the suggested algorithm is proved through simulation results.

III. OPTIMIZATION PROBLEM

The harmonic circuit model of a bus consisting of a single-tuned filter, linear and nonlinear loads involved in this study is presented in Fig. 1. The filter provides low impedance path to the system restricting the harmonic current source to go to the Thevenin's impedance, $R_{THK} + jX_{THK}$, and must be confined to flow to the impedance of the filter.

A. OBJECTIVE FUNCTIONS

The presented optimization problem can be formalized through four objectives: maximize the power factor, minimize the total harmonic voltage distortion, minimize the total demand distortion, and minimize the cost of the filter.

After some complex mathematical modeling equations, the different criteria are given in (1)– (4), described as follows:

1) MAXIMUM POWER FACTOR, PF

$$PF = \frac{P_L}{I_S V_L} = \frac{\sum V_{LK} I_{SK} \cos(\theta_K - \phi_K)}{\sqrt{\sum I_{SK}^2} \sqrt{\sum V_{LK}^2}} \quad (1)$$

where P_L , V_L and I_S are load power, load voltage and current source, respectively. V_{LK} and I_{SK} are load voltage and current source, respectively, at the K th harmonic order. Also, θ_K , ϕ_K are the angles of V_{LK} and I_{SK} in rad, respectively.

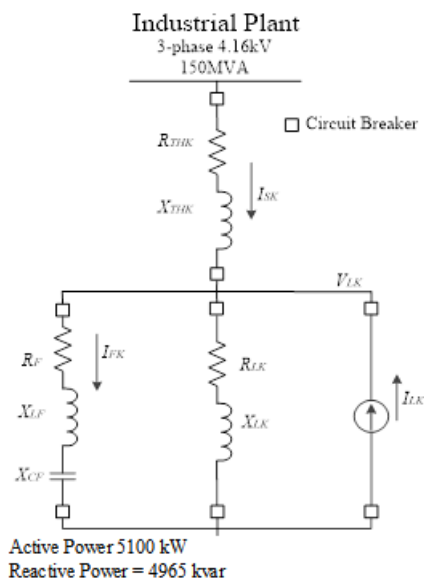

FIGURE 1. The system under study

2) MINIMUM TOTAL HARMONIC VOLTAGE DISTORTION, *THDV*

$$THDV = \frac{\sqrt{\sum_{K>1} V_{LK}^2}}{V_{L1}} \quad (2)$$

where V_{L1} is the load voltage at the fundamental frequency.

3) MINIMUM TOTAL DEMAND DISTORTION, *TDD*

$$TDD = \frac{\sqrt{\sum_{K>1} I_{SK}^2}}{I_L} \quad (3)$$

where I_L is the maximum current demand at point of common coupling (PCC).

4) MINIMUM INVESTMENT COST OF THE FILTER, *COST*

$$Cost = \sum_{K=1} k_C \cdot Q_C + k_L \cdot Q_L + k_R \cdot P_R \quad (4)$$

where the cost coefficients of the filter are given by k_C (\$/kvar), k_L (\$/kvar) and k_R (\$/kW). The total of the filter cost including the price of capacitors, inductors and resistors is proportional to the powers of the different elements of the filters, Q_C , Q_L and P_R respectively [19].

B. CONSTRAINTS

This optimization includes some constraints including the practical capacitor following the standard, the quality factor, and the resonance constraints.

By complying with IEEE Std 18-2012 [28], overloading of the capacitors should be avoided for reliability and proper circuit operation of the system. This can be done by setting rms capacitor voltage (V_C), peak capacitor voltage (V_{CP}), nominal current (I_C) and reactive power (Q_C) less than 110%, 120%, 135% and 135%, correspondingly.

Also, the value of quality factor QF is important, and it needs to be measured where low value of QF has high resistance which results in increasing the power losses within the filter. Therefore, there are standard limitations considered in this paper to limit QF . It is specified between 20 to 100 [29].

In addition, the amplification of current and voltage caused from series and parallel resonance respectively will result in damage to the circuit. The problems related with both resonances are usually caused from filter detuning where the common mechanisms are capacitor fuse blowing, capacitance and inductance manufacturing tolerance, temperature and system variants. Therefore, it is becoming beneficial for the filter to avoid the resonances by tuning 3–10% from the desired harmonic frequency, and the harmonic order activating resonance is always less than tuned harmonic order [3], [29].

On the basis of the description above, the paper’s multi-objective problem can be formulated as below:

$$\begin{aligned} f_1(x) & PF(R, X_C, X_L) \\ f_2(x) & THDV(R, X_C, X_L) \\ f_3(x) & TDD(R, X_C, X_L) \\ f_4(x) & Cost(R, X_C, X_L) \end{aligned}$$

Subject to:

Capacitor Capability Limits follows IEEE Std 18-2012

h is tuned 9% from the desired harmonic frequency

$$h > h_r$$

$$20 \leq QF \leq 100$$

where h and h_r are harmonic order and harmonic order activating resonance, respectively.

IV. PROPOSED APPROACH

The high-performance MIDACO technique is employed as an optimization tool to solve the multi-objective problem formulation. The software is an innovative optimization solver, where the software implements an extended ant colony optimization (ACOMi) combined with the oracle penalty method for constraint handling [22], [23]. To solve the multi-objective problem, MIDACO applies the concept of utopia-nadir balance, which is different from multi-objective since they consider four or more objectives [30].

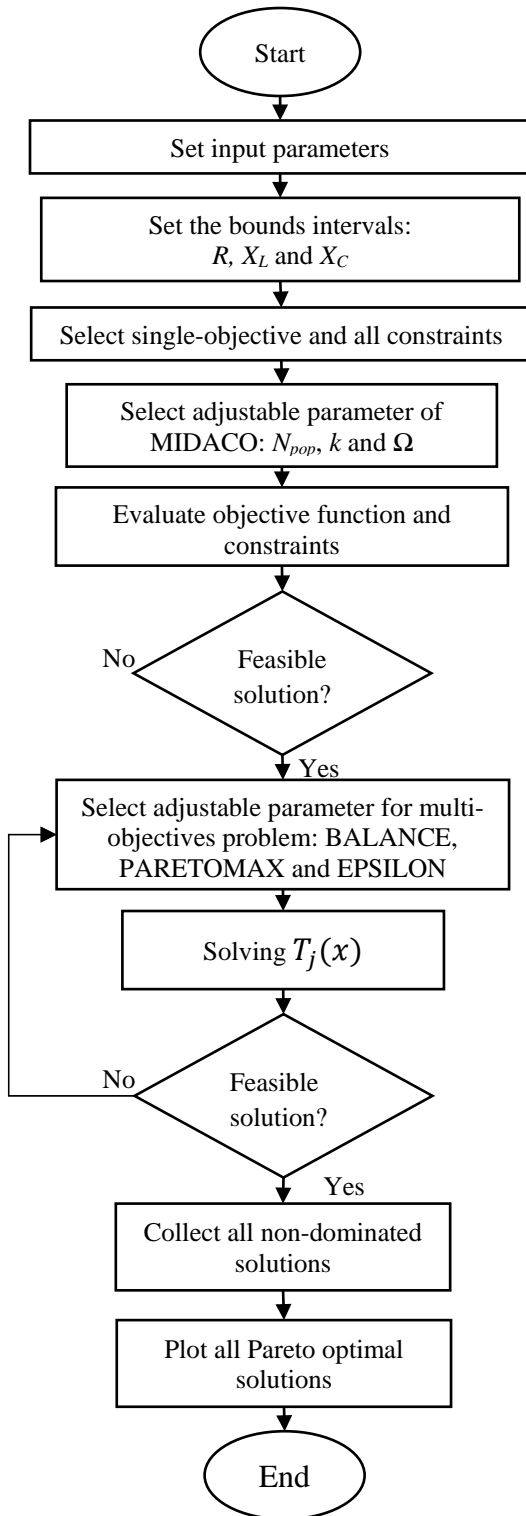

FIGURE 2. Flowchart of multi-objective optimization using MIDACO

MIDACO implements the extension of ACO metaheuristics, where the algorithm is based on stochastic Gauss approximation technique. Instead of a pheromone table, the methodology is based on pheromone-controlled probability

functions (PDFs) where the advantage of ACOmi can be seen in [22]. There are two parameters implemented in the proposed algorithm, which are ants (N_{pop}) and kernels (k). The penalty method is simple and easy to use. However, the use of this method often becomes a challenging problem because it is difficult to gain adequate performance. Therefore, MIDACO introduced the oracle penalty method to handle constraints [23]. For a given constrained problem, this method adjusts just one single parameter, called the oracle (Ω), where the parameter aims to find equal or slightly better global solutions. For multi-objective problems, the proposed concept is created from the utopia-nadir balance, where the utopia U_i and nadir N_i are formally defined as following [26]:

$$U_i = \min \{f_i(x) \forall x \in \mathcal{F}\} \quad (6)$$

$$N_i = \max \{f_i(x) \forall x : \exists k \neq U_k\} \quad (7)$$

where $f_i(x)$ is the global minimum of the respective objective among all solutions x . Different from the utopia, the nadir N_i represents the worst objective function where $f_i(x)$ corresponds to the utopia U_k of any other objective $f_k(x)$.

From the information given in (6) and (7), MIDACO introduced the BALANCE parameter which is different from traditional multi-objective approaches in such regard. By default, this is the middle part of the Pareto front, as this part provides the best equally balanced trade-off between all individual objective functions. Besides, this parameter also can be tuned to any other part of the Pareto front [27], [30].

The given weighted distance $d_i^j(x)$ and average distance $D_j(x)$ are defined in (8) and (9) below, respectively:

$$d_i^j(x) = w_i^j \frac{f_i(x) - U_i}{N_i - U_i} \quad (8)$$

$$D_j(x) = \frac{\sum_{i=1}^M d_i^j(x)}{M} \quad (9)$$

Then, the balance parameter, B_j , in (10) expresses the average distance to each objective of utopia and nadir, which described as following:

$$B_j(x) = \sum_{i=1}^M |d_i^j(x) - D_j(x)| \quad (10)$$

From (8)–(10), the objective function T can be defined as

$$T_j(x) = \sum_{i=1}^M d_i^j(x) + B_j(x) \quad (11)$$

For multi-objective optimization, the main advantage of utopia-nadir balance in MIDACO is that the proposed algorithm focuses its search effort on a particular area of the Pareto front without needing to measure the amount of scaling/weighting factor and particularly highlights a single point of the Pareto front as the MIDACO solution. In addition, the parameter of PARETOMAX can be tuned to define the maximal number of non-dominated solutions, while EPSILON defines the precision used for its multi-objective Pareto-dominance filter. Refer to Fig. 2 for the flowchart algorithm of MIDACO.

V. SIMULATED RESULTS

The values of fundamental frequency supply voltage, short circuit power, 3-phase inductive load and reactive power involved in this study are given in Fig. 1. From the figure, the impedances of the single-phase equivalent circuit are $R_{TH1} = 0.01154 \Omega$, $X_{TH1} = 0.1154 \Omega$, $R_{L1} = 1.742 \Omega$ and $X_{L1} = 1.696 \Omega$. The voltage and current harmonic source, which are randomly selected and deliberate in this study, are given in Table I below. All the cost coefficients of the filter are given by $k_C = 0.05 \text{ \$/kvar}$, $k_L = 250 \text{ \$/kvar}$ and $k_R = 100 \text{ \$/kW}$ [19].

TABLE I
VOLTAGE AND CURRENT HARMONICS OF THE SYSTEM UNDER STUDY

h	$V_{SK} (\% V_{S1})$	$I_{LK} (A)$
5	5	33
7	3	25
11	2	8
13	1	9

Table II shows the summary of simulated results of multi-objective optimization with different impacts of the BALANCE parameter.

TABLE II
SIMULATED RESULTS OF MULTI-OBJECTIVE OPTIMIZATION WITH DIFFERENT BALANCE PARAMETER

Setting	1	2	3	4	5	6
BALANCE Parameter	0	1.0	2.0	0.411 1	0.963 1	0.851 4
X_C	4.43	4.71	4.57	4.57	4.57	4.57
R	0.009 3	0.046 9	0.009 4	0.014 3	0.009 2	0.009 4
X_L	0.196 2	0.186 8	0.194 8	0.188 1	0.181 2	0.190 9
PF	95.43	93.54	94.69	94.32	93.85	94.48
THDV	2.09	1.91	2.00	1.91	1.84	1.94
TDD	1.55	1.84	1.63	1.72	1.82	1.68
Cost	59677	60187	59013	59428	59692	59146

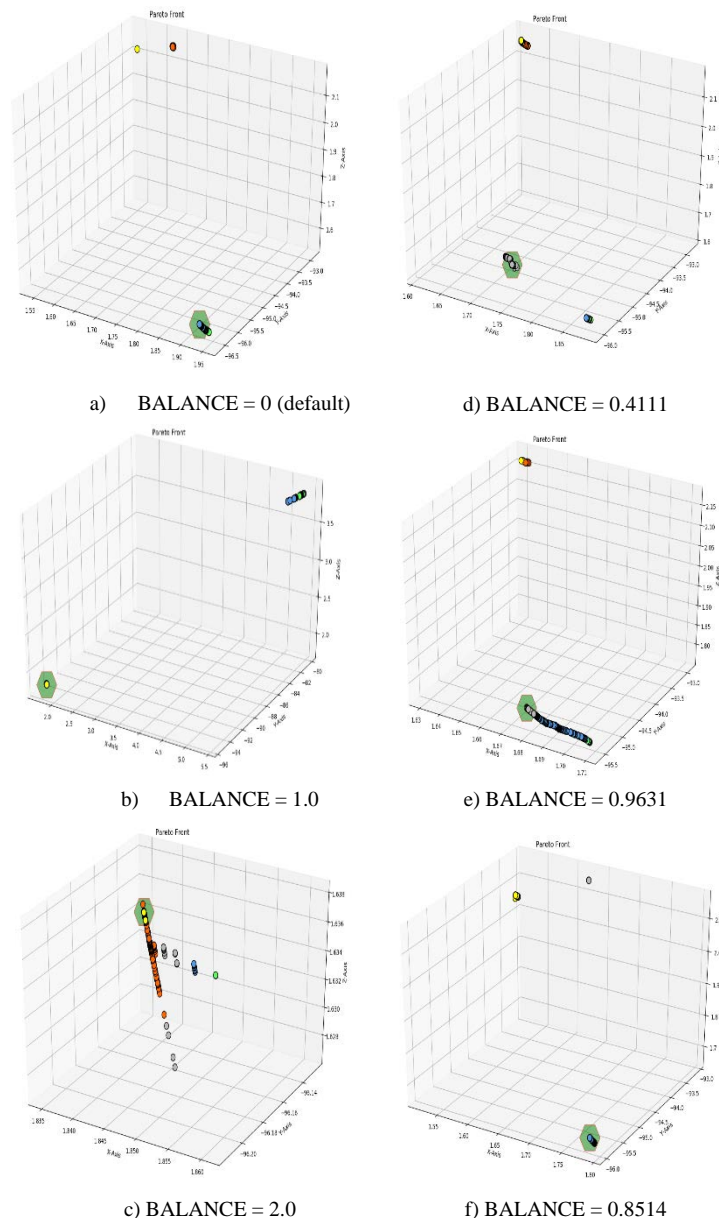

FIGURE 3. The impact of the BALANCE parameter on the solution

The parameter specifications used for controlling MIDACO as N_{pop} , k , and Ω have been set to default where MIDACO will dynamically change N_{pop} per generation, maximum k is fixed to 100 and $\Omega = 10^9$. For multi-objective problems, the parameters PARETOMAX and EPSILON are set to 1000 (default) and 0.0001, respectively. From Table II, the first setting is when the BALANCE parameter is set to 0 (default). For this setting, MIDACO will focus its search effort on the part of the Pareto front which offers best equally balanced trade-off between all objectives. For settings 2 and 3, the parameter is set to BALANCE = 1.0 or 2.0, where MIDACO will focus its search effort exclusively on the first and second objective, respectively. For settings 4 to 6, the search effort

represents some unequal priority between objectives. Based on the table, the results show that the optimal filter can be obtained with different optimal solutions considering four objective functions simultaneously where the BALANCE parameter is significant and has a great impact to each of the solutions. Fig. 3 clearly demonstrates the impact of varying the BALANCE parameter for each of the simulations on the position of the MIDACO solutions among the Pareto front. Table III shows simulated results for single-objective optimization solutions of the best: 1) *PF*, 2) *THDV*, 3) *TDD*, and 4) *Cost*.

TABLE III
SIMULATED RESULTS OF SINGLE-OBJECTIVE OPTIMIZATION

No. of Cases	X_c	R	X_L	PF	THD V	TD D	Cost
f_1	4.7 1	0.025 2	0.163 9	91.2 4	2.19	2.29	63196
f_2	1.8 0	0.011 9	0.089 1	69.8 8	1.41	2.23	10563 5
f_3	2.1 7	0.023 5	0.162 8	92.2 1	1.99	2.17	62313 4
f_4	4.7 1	0.001 1	0.002 2	67.3 7	22.48	5.99	4038

The results in Table III are compared with Table II to highlight the efficiency, where the results prove that the multi-objective optimization achieved a great economic effectiveness in improving the power factor and produced great reduction of the distortion indexes *THDV* and *TDD*. Table IV shows a comparison of the computation time between multi-objective and single-objective optimization up until the maximum number of function evaluations were reached.

TABLE IV
COMPARISON OF COMPUTATION TIME OF MULTI-OBJECTIVE AND SINGLE-OBJECTIVE OPTIMIZATIONS

Criteria	Multi-objective						Single-objective			
	1	2	3	4	5	6	f_1	f_2	f_3	f_4
Time, t/s	22	25	23	23	24	23	20	21	20	20
No. of Iterations	20000									

The results show that the computation time for multi-objective optimization is a bit slower compared to the results for single-objective optimization. This is because the PARETOMAX and EPSILON parameters used by MIDACO for its multi-objective Pareto-dominance filter are main influences on the amount of Pareto points stored and its internal calculation time.

As described in the Section III, the PARETOMAX and EPSILON parameters give an impact to the number of Pareto points. Therefore, Table V has been added to prove that increasing the values of PARETOMAX will result in increasing collected Pareto points. Consequently, it will slow down the internal calculation time of MIDACO because of

more memory that needs to be stored as shown in Table V. In this test, only one parameter is varying, which is PARETOMAX.

TABLE V
EFFECTS OF CHANGING PARETOMAX PARAMETER

PARETOMAX	Computation time, t/s					
	Setting					
	1	2	3	4	5	6
10	21	22	21	22	21	22
100	21	22	22	22	22	22
1000	22	25	23	23	24	23
PARETOMAX	Number of Pareto points stored					
	Setting					
	1	2	3	4	5	6
10	10	10	10	10	10	10
100	100	100	100	100	100	100
1000	973	1000	1000	445	1000	496

Table VI shows the effects of changing different values of the EPSILON parameter to the amount of Pareto points stored and the internal computation time. In this test, only one parameter is varying, which is EPSILON.

From Table VI, the results show that small values of the EPSILON parameter result in an increase in the amount of Pareto points stored in MIDACO. Although the base case (EPSILON set to 0.00001) speed is slower, it proves that the solution has a higher chance of a new solution being introduced into the Pareto points.

TABLE VI
EFFECTS OF CHANGING EPSILON PARAMETER

EPSILON	Computation time, t/s					
	Setting					
	1	2	3	4	5	6
0	22	22	22	22	22	22
0.0001	22	22	22	22	23	23
0.00001	22	25	23	23	24	23
EPSILON	Number of Pareto points stored					
	Setting					
	1	2	3	4	5	6
0	27	107	23	36	47	29
0.0001	77	513	418	263	168	368
0.00001	973	1000	1000	445	1000	496

Table VII presents the effects of different sets of ant and kernel parameters on the multi-objective simulated results of power factor. In MIDACO, both control parameters influence the sensitivity of the solutions, which must be used together.

TABLE VII
EFFECTS OF ALTERING N_{pop} AND k PARAMETERS

Set	Parameters		PF					
	N_{pop}	k	1	2	3	4	5	6
1	30	5	93.79	96.00	93.59	93.12	93.15	93.90
2	500	10	93.43	74.15	29.05	94.65	93.03	92.92
3	100	50	68.39	95.86	36.69	36.63	36.05	69.12
4	0	100	95.43	93.54	94.69	94.32	93.85	94.48

The results in Table VII show that tuning the parameters of ants and kernels will result in inaccurate solutions. By increasing number of kernels, a better solution can be reached where the sensitivity analysis results in the table verified that setting 4, which is the current proposed setting, is the best setting for all simulations for multi-objective optimization.

Table VIII shows the results when modifying the value of the oracle parameter.

TABLE VIII
EFFECTS OF DIFFERENT ORACLE PARAMETERS

Setting	Parameter	PF					
	Oracle	1	2	3	4	5	6
1	10^3	36.4	93.5	94.6	40.2	92.3	36.6
		4	4	9	4	7	2
2	10^6	93.6	93.5	94.6	51.3	93.6	94.0
		5	4	9	5	6	3
3	10^9	95.4	93.5	94.6	94.3	93.8	94.4
		3	4	9	2	5	8

From Table VIII, the results verified that the oracle parameter directly corresponds to the ideal solution from given problems. However, it is very sensitive where the selections of this parameter can result erroneous. The results show that the base setting (setting 3) can be seen as a reasonable oracle choice for all simulations of multi-objective optimization.

Lastly, Table IX shows the improved value for fitness for the proposed technique when increasing the number of function evaluations. The consequences show that the proposed method seemed to have a better chance in attaining a global optimal solution when the maximized function number is reached.

TABLE IX
EFFECTS OF INCREASING MAXIMUM NUMBER OF FUNCTION EVALUATIONS, MAXEVAL

Setting	PF					
MAXEVAL	1	2	3	4	5	6
1000	93.51	75.09	75.09	93.53	93.53	94.14
5000	93.52	77.13	75.09	94.31	93.55	94.52
15000	95.45	78.54	94.69	94.32	93.85	94.48
20000	95.43	93.54	94.69	94.32	93.85	94.48

Table X indicates the restrictions for the main capacitors of the filter. From Table X, the results show that all capacitors are capable to operate below the standard limitation.

TABLE X
THE CAPACITOR CAPABILITY LIMITS

Setting	V_{CP} (%)	V_C (%)	I_C (%)	Q_C (%)
1	68.49	89.96	99.26	86.43
2	69.27	89.48	101.45	86.35
3	68.74	89.77	99.92	86.33
4	68.93	89.65	100.45	86.31
5	69.17	89.55	101.13	86.35
6	68.85	89.70	100.21	86.32
Standard	120	110	135	135

The filter impedance in the resonant circuit and the effects of resonance peak when all objectives are equally balanced are shown in Fig. 4.

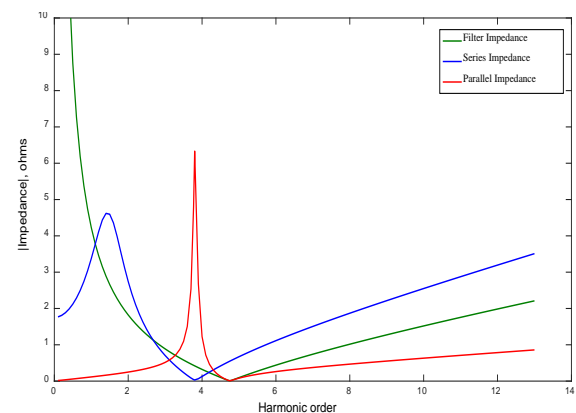

FIGURE 4. Impedance response with equally balanced objectives (setting 1)

The characteristic of the filters responses in Fig. 4 is evaluated and explained as following:

- Adding the single-tuned filter into the system can result in the occurrences of resonances with the interaction between Thevenin's impedance and compensated load.
- In series resonance, the value of inductance and capacitance reactance are equal, thus making resistance at a minimum. In contrast, the resistance is at a local maximum for parallel resonance.
- The value of R determines the resonant peak. The lower value of R results in a high value of Q where the resonant peak becomes sharper. This results in high frequency selectivity and better harmonic attenuation. However, the passband is reduced with higher Q .
- It is recommended to always tune the filter below the harmonic to be filtered to avoid both resonances.

VI. COMAPRISON WITH OTHER TECHNIQUES

The effectiveness of the proposed method is shown by comparing the results with other highly competitive evolutionary multi-objectives algorithms which are genetic algorithm (GA), Non-dominated sorting Genetic Algorithm (NSGA-II) and Multi Objective Particle Swarm Optimization (MOPSO).

In GA, the optimization is inspired based on the process of natural selection, where the optimal solution is found by relying on bio-inspired operators. After generating a random initial population, then GA selects a group of individuals (parents) from the current population who are strong enough to contribute their genes and create children to form the next generation via reproduction. The main elements of GA consist of selection method, crossover method, crossover probability, mutation method, mutation probability and replacement method [31].

Besides, GA is a well-known solver to solve multi-objective optimization problems since it is a population-based method. By modification of single-objective optimization, GA is able to find multiple non-dominated solutions in one run. Besides, GA has the ability to search different regions of a good solution where the crossover operator may exploit the structures of the good solutions with respect to different objectives to create non-dominated solutions.

The concept of GA has inspired Srivinas and Deb to extent this concept and proposed NSGA to optimize multi-objectives problem where NSGA-II is the updated version from classical NSGA [32]. The NSGA works by improving the adaptive fit of a population of candidate solutions to a Pareto front constrained by a set of objective functions. The algorithm uses an evolutionary process with surrogates for evolutionary operators including selection, genetic crossover, and genetic mutation. The only different way of NSGA when compare to GA is how the selection operator working while the crossover and mutation operator remains same. The population is sorted into a hierarchy of sub-populations based on the ordering of Pareto dominance. Similarity between members of each sub-group is evaluated on the Pareto front, and the resulting groups and similarity measures are used to promote a diverse front of non-dominated solutions.

On the other hand, PSO was inspired by having a population or swarming behavior flocks of fish or birds. In PSO, each of the “bird” or called as “particle” in the search space is represented every single potential solution [33]. The particles fly through the search space until the better positions are discovered. Then, it will guide to the entire swarm best-known position. The process continues repetitively until an acceptable solution is eventually discovered. However, due to its limitation on solving only single objective, a new concept known as MOPSO has been proposed to solve multi-objective problems and have been

successfully developed in many applications until now [34], [35].

Table XI shows the comparison of simulated results of the proposed method (setting 1), GA, NSGA-II and MOPSO for solving the multi-objective problem. In order to simulate using GA, three parameters are used, where crossover rate, mutation probability, and population size are set to 0.8, 0.001 and 50, respectively. In order to simulate NSGA-II, four parameters are used, where mutation rate, mutation percentage, crossover percentage and population size are set to 0.02, 0.4, 0.7 and 50, respectively. Contrary, MOPSO has eleven parameters to be used where all parameters are set as follows: population size is 200, repository size is 100, inertia weight is 0.5, inertia weight damping rate is 0.99, global learning coefficient is 1, personal learning coefficient is 2, number of grids per dimension is 7, inflation rate 0.1, leader selection pressure is equals 2, deletion selection pressure is set at 2, and mutation rate 0.1.

TABLE XI
COMPARISON OF THE SYSTEM PERFORMANCE

Methods	X_c	R	X_L	PF	THD V	TD D	Cost
MIDAC O	4.4 3	0.009 3	0.1 9	95.4 3	2.09	1.55	59,678
GA	3.1 1	0.025 8	0.5 2	94.6 5	4.72	0.59	173,25 9
NSGA-II	2.1 2	0.245	1.0 2	96.3 0	8.55	0.74	47,138
MOPSO	4.0	0.013 4	0.1 6	99.2 0	4.05	0.76	90,206

From Table XI, it can be pointed out from the comprehensive evaluation of MIDACO and GA that the proposed has outperformed GA where the optimal solutions are attained with overall better power factor, lower *THDV* and great investment cost effectiveness. After performing simulation using NSGA-II, the comparison of the results shows the advantages of MIDACO which gives better accuracy wherein the value of *THDV* for NSGA-II is too high and beyond the IEEE standard limit. In addition, the simulation using MOPSO also shows that the results have high value of *THDV* where the investment cost of the filter also very high when compare to the proposed method.

The comparison of computation time and maximum function evaluation between the proposed method with GA, NSGA-II and MOPSO are presented in Table XII.

TABLE XII
COMPARISON OF COMPUTATION TIME AND MAXIMUM FUNCTION EVALUATION FOR ALL METHODS

	Computation Time, t/s	No. of Iterations
MIDACO	22.00	20000
GA	14.14	197
NSGA-II	39.768	100
MOPSO	209.64	2000

From the table, the results proved that the biggest advantage of the proposed method is less computation time compare to the other methods, where it can process thousands of iterations within a few seconds.

VII. CONCLUSIONS

This paper deals with non-dominated solutions when optimizing parameters of a single-tuned filter based on general multi-objective problems, which are maximized power factor, minimized total harmonic voltage distortion, minimized total demand distortion and minimized investment cost of the filter. A mathematical harmonic modeling has been developed and numerically evaluated on the harmonics level with possible resonance problems using a new algorithm known as Mixed Integer Distributed Ant Colony Optimization. A case study has been tested using the proposed method where the results show that the algorithm attains the Pareto front of the problem and tolerates the selection of its parameters to the most effective solution with satisfaction of all objective functions and constraints involved while complying with IEEE Std 18-2012. The effectiveness and advantage of the proposed method is demonstrated with other highly competitive evolutionary multi-objectives algorithms in power quality area. The numerical results revealed that the proposed method does highly benefit for multi-objective approaches over single-objective optimization on a comprehensive passive filter design.

REFERENCES

- [1] M. H. J. Bollen *et al.*, "Power Quality Concerns in Implementing Smart Distribution-Grid Applications," *IEEE Trans. Smart Grid*, vol. 8, no. 1, pp. 391–399, 2017.
- [2] B. Singh, A. Chandra, and K. Al-Haddad, *Power Quality Problems and Mitigation Techniques*. Chichester: Wiley, 2015.
- [3] J. C. Das, *Power System Harmonics and Passive Filter Designs*. 2015.
- [4] S. Mishra, "A hybrid least square-fuzzy bacterial foraging strategy for harmonic estimation," *IEEE Trans. Evol. Comput.*, 2005.
- [5] F. N. Belchior, L. R. De Lima, P. F. Ribeiro, and J. F. C. Castro, "A novel approach towards passive filter placement," in *IEEE Power and Energy Society General Meeting*, 2015, vol. 2015–Sept.
- [6] D. Li, K. Yang, Z. Q. Zhu, and Y. Qin, "A novel series power quality controller with reduced passive power filter," *IEEE Trans. Ind. Electron.*, vol. 64, no. 1, pp. 773–784, 2017.
- [7] S. J. Chang, H. S. Hou, and Y. K. Su, "Automated passive filter synthesis using a novel tree representation and genetic programming," *IEEE Trans. Evol. Comput.*, 2006.
- [8] J. Yu, Y. Li, Y. Cao, and Y. Xu, "An impedance-match design scheme for inductively active power filter in distribution networks," *Int. J. Electr. Power Energy Syst.*, vol. 99, pp. 638–649, 2018.
- [9] A. Khan, A. Gastli, and L. Ben-Brahim, "Modeling and control for new LLCL filter based grid-tied PV inverters with active power decoupling and active resonance damping capabilities," *Electr. Power Syst. Res.*, vol. 155, pp. 307–319, 2018.
- [10] R. A. Vural, T. Yildirim, T. Kadioglu, and A. Basargan, "Performance evaluation of evolutionary algorithms for optimal filter design," *IEEE Trans. Evol. Comput.*, 2012.
- [11] P. P. Biswas, P. N. Suganthan, and G. A. J. Amarantunga, "Minimizing harmonic distortion in power system with optimal design of hybrid active power filter using differential evolution," *Appl. Soft Comput.*, vol. 61, pp. 486–496, 2017.
- [12] S. R. Das, P. K. Ray, and A. Mohanty, "Improvement in Power Quality using Hybrid Power Filters based on RLS Algorithm," in *Energy Procedia*, 2017, vol. 138, pp. 723–728.
- [13] A. Kalair, N. Abas, A. R. Kalair, Z. Saleem, and N. Khan, "Review of harmonic analysis, modeling and mitigation techniques," *Renewable and Sustainable Energy Reviews*, vol. 78, pp. 1152–1187, 2017.
- [14] J. Arrillaga and N. R. Watson, *Power System Harmonics*. Chichester: Wiley, 2003.
- [15] N. H. B. Abdul Kahar and A. F. Zobaa, "Application of mixed integer distributed ant colony optimization to the design of undamped single-tuned passive filters based harmonics mitigation," *Swarm and Evolutionary Computation*, 2018.
- [16] S. H. E. Abdel Aleem, A. F. Zobaa, and M. E. Balcı, "Optimal resonance-free third-order high-pass filters based on minimization of the total cost of the filters using Crow Search Algorithm," *Electr. Power Syst. Res.*, vol. 151, pp. 381–394, 2017.
- [17] K. Abolfathi, M. Babaei, and A. Ahmarinejad, "Designing Optimal Passive Filters for Transformers under Harmonic Conditions," in *Energy Procedia*, 2017, vol. 141, pp. 411–417.
- [18] A. Karadeniz and M. E. Balcı, "Comparative evaluation of common passive filter types regarding maximization of transformer's loading capability under non-sinusoidal conditions," *Electr. Power Syst. Res.*, vol. 158, pp. 324–334, 2018.
- [19] J. C. Leite, I. P. Abril, M. E. de L. Tostes, and R. C. L. de Oliveira, "Multi-objective optimization of passive filters in industrial power systems," *Electr. Eng.*, vol. 99, no. 1, pp. 387–395, 2017.
- [20] M. Mohammadi, A. M. Rozbahani, and M. Montazeri, "Multi criteria simultaneous planning of passive filters and distributed generation simultaneously in distribution system considering nonlinear loads with adaptive bacterial foraging optimization approach," *Int. J. Electr. Power Energy Syst.*, vol. 79, pp. 253–262, 2016.
- [21] N.-C. Yang and M.-D. Le, "Multi-objective bat algorithm with time-varying inertia weights for optimal design of passive power filters set," *IET Gener. Transm. Distrib.*, vol. 9, no. 7, pp. 644–654, 2015.
- [22] M. Schlüter, J. A. Egea, and J. R. Banga, "Extended ant colony optimization for non-convex mixed integer nonlinear programming," *Comput. Oper. Res.*, vol. 36, no. 7, pp. 2217–2229, 2009.
- [23] M. Schlüter and M. Gerdtts, "The oracle penalty method," *J. Glob. Optim.*, vol. 47, no. 2, pp. 293–325, 2010.
- [24] M. Lopez-Ibanez and T. Stutzle, "The automatic design of multiobjective ant colony optimization algorithms," *IEEE Trans. Evol. Comput.*, 2012.
- [25] C. Solnon, "Ant colony optimization for multi-objective optimization problems," *IEEE Trans. Evol. Comput.*, vol. 18, no. 4, pp. 450–457, 2014.
- [26] M. Schlueter, C. H. Yam, T. Watanabe, and A. Oyama, "Many-objective optimization of interplanetary space mission trajectories," in *2015 IEEE Congress on Evolutionary Computation, CEC 2015 - Proceedings*, 2015, pp. 3256–3262.
- [27] M. Schlueter, C. H. Yam, T. Watanabe, and A. Oyama, "Parallelization Impact on Many-Objective Optimization for Space Trajectory Design," vol. 6, no. 1, pp. 1–6, 2016.
- [28] *IEEE Standard for Shunt Power Capacitors IEEE Power and Energy Society*, vol. 12, no. February, 2013.
- [29] J. C. Das, "Passive Filters - Potentialities and Limitations," *IEEE Trans. Ind. Appl.*, vol. 40, no. 1, pp. 232–241, 2004.
- [30] M. Schlueter and M. Munetomo, "MIDACO Solver User Manual 6.0," 2018.
- [31] D. E. Goldberg, *Genetic Algorithms in Search, Optimization, and Machine Learning*, vol. Addison-We, 1989.
- [32] N. Srinivas and K. Deb, "Multiobjective Optimization Using

- Nondominated Sorting in Genetic Algorithms,” *Evol. Comput.*, vol. 2, no. 3, pp. 221–248, 1994.
- [33] J. Kennedy *et al.*, “Particle swarm optimization,” *Neural Networks, 1995. Proceedings., IEEE Int. Conf.*, vol. 4, no. 3, pp. 1942–1948, 1995.
- [34] N. Ghorbani, A. Kasaeian, A. Toopshekan, L. Bahrami, and A. Maghami, “Optimizing a hybrid wind-PV-battery system using GA-PSO and MOPSO for reducing cost and increasing reliability,” *Energy*, vol. 154, pp. 581–591, 2018.
- [35] A. A. A. Elgammal and M. F. El-naggar, “MOPSO-based optimal control of shunt active power filter using a variable structure fuzzy logic sliding mode controller for hybrid (FC-PV-Wind-Battery) energy utilisation scheme,” *IET Renew. Power Gener.*, vol. 11, no. 8, pp. 1148–1156, 2017.



Ahmed Faheem Zobaa (M'02-SM'04)

received his B.Sc.(Hons), M.Sc., and Ph.D. degrees in Electrical Power & Machines from Cairo University, Egypt, in 1992, 1997, and 2002, respectively. Also, he received his Postgraduate Certificate in Academic Practice from the University of Exeter, UK in 2010. Also, he received the Doctoral of Science from Brunel University London, UK in 2017. He was an Instructor during 1992-1997, a Teaching Assistant during 1997-2002, and an Assistant Professor during 2002-2007 at Cairo University, Egypt. From 2007 to 2010, he was a Senior Lecturer in renewable energy at University of Exeter, UK. Currently, he is a Senior Lecturer in electrical and power engineering, an MSc Course Director and a Full Member of the Institute of Energy Futures at Brunel University London, UK. His main areas of expertise include power quality, (marine) renewable energy, smart grids, energy efficiency, and lighting applications.

Dr. Zobaa is an Executive Editor for the *International Journal of Renewable Energy Technology*. Also, he is an Editor-in-Chief for *Technology and Economics of Smart Grids and Sustainable Energy*, and *International Journal of Electrical Engineering Education*. He is also an Editorial Board member, Editor, Associate Editor, and Editorial Advisory Board member for many international journals. He is a registered Chartered Engineer, Chartered Energy Engineer, European Engineer, and International Professional Engineer. He is also a registered member of the Engineering Council U.K., Egypt Syndicate of Engineers, and the Egyptian Society of Engineers. He is a Senior Fellow of the Higher Education Academy of U.K. He is a Fellow of the Institution of Engineering and Technology, the Energy Institute of U.K., the Chartered Institution of Building Services Engineers, the Institution of Mechanical Engineers, the Royal Society of Arts, the African Academy of Science, and the Chartered Institute of Educational Assessors. He is a senior member of the Institute of Electrical and Electronics Engineers. Also, He is a member of the International Solar Energy Society, the European Power Electronics and Drives Association, and the IEEE Standards Association.