



+62 813 8765 4578

081387654578

<https://dinastipub.org/DIJMS>editor@dinastipub.org

MODEL BUYING DECISION AND REPEAT PURCHASE: PRODUCT QUALITY ANALYSIS

(Case Study of Bank Permata Syariah Jakarta KPR Financing Customers)

¹⁾Phong Thanh Nguyen, ²⁾ Hapzi Ali, ³⁾Agung Hudaya

¹⁾ Departemen of Project Management, Ho Chi Minh City Open University, Vietnam,

²⁾ Senior Lecturer, Universitas Mercu Buana (UMB), Jakarta Indonesia

³⁾Lecturer, Universitas Mercu Buana (UMB), Jakarta Indonesia

ARTICLE INFORMATION

Received: Date Month Year

Revised: Date Month Year

Issued: Date Month Year

(filled in by Editor)

Corresponding author: Hapzi Ali

E-mail:

phong.nt@ou.edu.vn;

hapzi.ali@mercubuana.ac.id;

agunghudaya24@gmail.com



DOI:10.31933/DIJMS

Abstract: Sharia mortgage financing at PT Bank Permata Syariah Business Unit. Targets and achievements of Sharia KPR financing up to August 2018 there is a high enough *gap* because of not achieving the target. In addition, the ranking of Bank Permata Syariah which is still far below shows that the contribution of mortgage financing has not been high. This is caused by many factors including the financing process and product quality that still needs to be improved so that it affects the Buying decisions and also the repurchase of Bank Permata Syariah mortgage financing. This study aims to determine the effect of process and product quality on Buying and repurchase decisions. The design of this study was *explanatory*. The sampling technique in this study was the Bank Permata Syariah customers in the South Tangerang Region and filled out the questionnaire using the *accidental sampling* method but still fulfilled the specified criteria. The sampling technique is *purposive sampling* with a total population of 150 Permata Bank customers in the South Tangerang Region. By using the Slovin formula, a sample of 100 customers is obtained, the defined margin of error is 10% or 0.10. Quantitative analysis method with SEM analysis tools and Smart PLS and SPSS tools.

Keywords: Purchase Decision Repurchase, Product Quality

INTRODUCTION

Islamic banks have various financing products. Ranging from working capital financing provided for small businesses, as well as consumer financing to individuals such as housing ownership financing or mortgages. As for the related mortgage financing provided by Islamic banks the difference is the contract used. If conventional mortgages are known as sale and purchase agreement contracts, Syariah mortgages have several alternative contract options that can be utilized by customers. The choice of the contract is of course dependent on the intended use and benefits of the mortgage financing that will be submitted by the customer.

There is a gap in achieving the target of Bank *Permata Syariah* KPR financing with the realization of financing provided to customers until August 2018. This can be seen in Figure 1.1 Target and Realization of Financing Disbursements by August 2018.

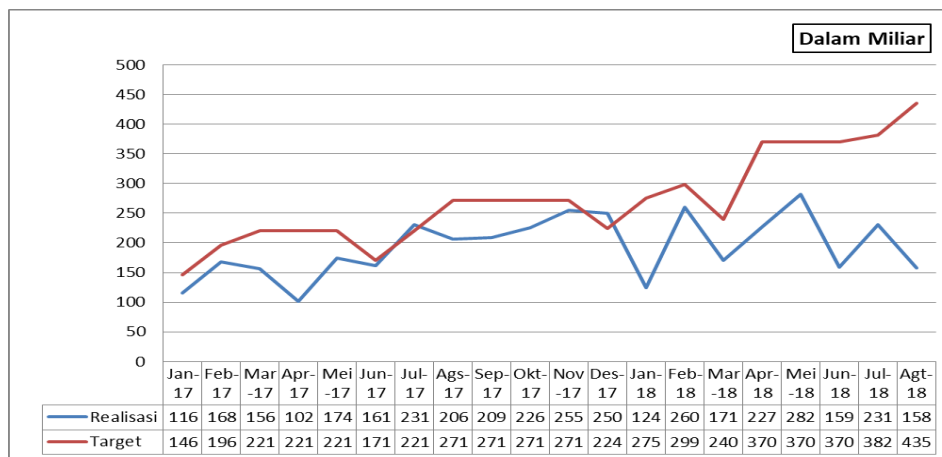

Figure 1.1 Target and Realization of Sharia Mortgage Disbursement as of August 2018
 Source: Data processed (2018)

Identification of problems

Based on the background of the problem, it can be identified as follows:

- 1) There is a gap between the target and the higher realization of *Syariah* mortgage financing that is charged by management. Not achieving the financing target that occurs every month which causes the gap is higher
- 2) Rating of Bank *Permata Syariah* which still ranks number 7 among Islamic banks shows that the contribution of financing, especially mortgages is still far from other Islamic banks.
- 3) From the two identification problems above, according to the researchers, it is caused by price competition given to customers, where the price / margin of Bank *Permata Syariah* is still less attractive compared to other banks. In addition, the financing process that is quite long and requires quite a lot of documents also affects the customer's Buying decisions which also affect the achievement of targets. Another factor is the quality of the product which still needs to be adjusted to the customers' needs and needs.

In accordance with the problems raised in the study, the objectives of this study are:

- 1) To analyze and determine the effect of Product Quality to Buying Decision.
- 2) To analyze and determine the effect of Product Quality on Repeat Purchase.
- 3) To analyze and find out the influence of the Buying Decision to Repeat Purchase.

LITERATURE REVIEW

Buying decision

Kotler and Keller (2012) state that at the evaluation stage, consumers from preferences among brands in a set of choices and perhaps also from the intention to buy the most preferred brand.

Kotler and Amstrong (2012) adds that the consumer buyer behavior is the behavior of individual purchases and household end consumers who purchase goods and services for personal consumption .

According to Kotler and Keller (2012), humans generally act rationally and consider all types of information available and consider everything that can arise from their actions before committing to a particular behavior.

According to Kotler and Keller (2012) purchase decision has a dimension as: Product selection, selection *Brand* (Brand), the selection of distributors, the purchase amount, the timing of the visit, your payment method

Repeat Purchase

Repeat Purchase (repurchase) is a behavior that appears in response to an object. Interests repurchase (*Repurchase*) indicates the customer's desire for time to come. Repurchase behavior is often associated with Product Quality. However, there are differences between the two. If loyalty reflects a psychological commitment to a particular brand, then the repurchase behavior is simply the purchase of the same specific brand repeatedly. (Tjiptono, 2014).

One of the effects of buying a product is repurchase. But what's interesting is the relationship with satisfaction, repurchase can include two characteristics, namely *intention* and *behavior*. *Repurchase intention* and *Repurchase behavior* are certainly different. In accordance with the form of the desire to repurchase and also repurchase behavior.

In Husaeni's research, Uus Ahmad. (2017) also includes research which states that satisfaction is not directly related to *repurchase* , but satisfaction will affect again that it is not wrong that customer satisfaction affects repurchase when viewed from psychological research where *satisfaction* drives *intentions* and *intentions* drive *behavior*.

The more experience a person has of a brand or product, the more repeat purchases that occur on products that get a good evaluation. Atikanit , Ratchadet, Visitnitikija, Chinnaso (2017) dimensions that make up the buyback is: p encarian further information, to understand the product , want to try the product and the *outlet* .

Product quality

According to Kotler and Keller that product quality is the ability of a product to deliver performance results that match or even exceed what customers expect.

Senad a theory that, in the research journal Anggita, R (2017), Characteristics of product product quality is in the ability to meet the needs that have been determined and latent. This product is defined as everything that can be offered to the market to get attention, expertise, usability or consumption of wants or needs.

According to Tjiptono (2017) which reflects the quality of all dimensions of product offerings that generate benefits for customers. The quality of products in the form of goods and services is determined by dimensions.

From the above definition it can be concluded that the quality of the product is the level or level of good or bad something that consists of all factors inherent in the goods or services, so that the product has the ability to be used as desired by consumers of the product.

According to Kotler and Keller (2009) there are nine dimensions of product quality, namely:

- 1) The *form* which includes the size, shape, or physical structure of the product.
- 2) Features, product characteristics that complement the basic function of the product

- 3) The quality of performance (*performance quality*), is the level where the main characteristics of the product is operating.
- 4) Impression of quality (*perceived quality*) is often spelled out as a result of the use of measurements made indirectly because there is a possibility that consumers do not understand or lack information about the product concerned.
- 5) Endurance (*durability*), the size of the operating life expectancy of products in a regular or stressful conditions, is a valuable attribute for certain products.
- 6) Kendalan (*reability*), is a measure of the probability that the product will idak malfunction or fail within a certain time.
- 7) Ease of repair (*repairability*), is a measure of the ease of product repair when the product is not functioning or failing.
- 8) Style (*style*), describes the appearance and taste of the product to the buyer.

Framework

Based on the research objectives, literature review, previous research and the relationship between variables, the analytical framework in this study is presented in the form of Figure 1 . Where the variable quality of the product is an independent variable, the variable purchase as the dependent variable and variable Buying decisions as intervening variables, or variables that mediate between independent variables with the dependent variable.

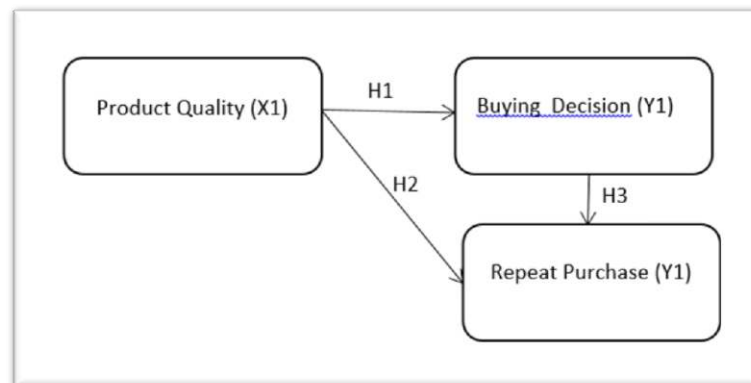

Hypothesis

Based on the problem examined, then a hypothesis is drawn as follows:

H1: Product quality influences Buying decisions

H2: Product quality influence repeat purchase

H3: Buying decisions affect repeat purchase

RESEARCH METHODS

This research was conducted at PT. Bank *Permata Syariah*, with a case study on KPR Bank Permata Syariah KPR customers in the South Tangerang area. The research will be conducted for three Academic Years (TA), starting from 2016/2017 until 2018/2019, or from October 2016 to September 2019.

The method of analysis of this study is a quantitative method and its analysis tool with *SEM* Before being analyzed by Path analysis, the instrument test (questionnaire) is tested first with the validity and reliability and Hypothesis tests. SEM analysis aids with the Smart PLS 3.0 application.

Process and product quality as independent variables, Buying decision as intervening variables and repurchase as dependent variables. To test intervening variables the path analysis method is used, asan extension of multiple linear regression analysis.

The method can be illustrated as shown in Figure 3.2. *above* with the path structure and sub structure as below:

$$Y = P_{yx_1} X_1 + P_{yx_2} X_2 + \epsilon_1$$

$$Z = P_{zx_1} X_1 + P_{zx_2} X_2 + P_{zy} Y + \epsilon$$

Note: X_1 = *Process* ; X_2 = *Product Quality* ; Y = *Purchase Decision* ; Z = *Repurchase* ; and ϵ = epsilon (other factors that influence)

FINDINGS AND DISCUSSION

Research result

There are three values that must be considered at this stage, namely *convergent validity*, *discriminant validity*, and *composite reliability*.

Convergent validity, the correlation between the score of reflexive indicators and the latent variable score. This research uses *loading* 0.5 to 0.6 is considered sufficient, because it is the initial stage of developing the measurement scale and the number of indicators per construct is not large, namely 2 (two) to 4 (four) indicators.

Discriminant validity, reflexive indicator measurement based on cross loading with its latent variables. Another method is by comparing the *square root of average variance extracted* (AVE) values of each construct with the correlation between other constructs in the model. If the initial measurement values of the two methods are better than the other construct values in the model, it can be concluded that the construct has a good *discriminant validity* value or vice versa. Accordingly, it is recommended that the measurement value be greater than 0.50.

Composite reliability, a block indicator that measures the internal consistency of construct indicators, shows the degree to which it indicates *common latent (unobserved)*. The construct is declared reliable if it has a *composite reliability* value above 0.70 and *Cronbach's alpha* above 0.60 even though it is not an absolute standard.

Convergent Validity

Convergent validity is used to determine instrument items that can be used as indicators of overall latent variables. The results of this test are measured based on the value of the *loading factor (outer loading)* of the construct indicator. The following *convergent validity* test results are presented in the table.

Table 1. Table of Convergent Validity Test Results .

Variable	Indicator	Outer Loadings	Information
Product quality	X2.1	0800	Valid
	X2.2	0.794	Valid
	X2.3	0.764	Valid
	X2.4	0901	Valid
	X2.5	0871	Valid
	X2.6	0.936	Valid
Buying decision	Y1.1	0.872	Valid
	Y1.2	0.787	Valid
	Y1.3	0810	Valid
	Y1.4	0842	Valid
	Y1.5	0867	Valid
	Y1.6	0832	Valid
Repeat purchase	Y2.1	0836	Valid
	Y2.2	0845	Valid
	Y2.3	0817	Valid

	Y2.4	0894	Valid
	Y2.5	0.786	Valid
	Y2.6	0834	Valid
	Y2.7	0795	Valid

Source: Data processed from Smart PLS output

The table shows that all *outer loading factors* have values greater than 0.5. So that this measurement can be concluded has met the requirements of convergent validity. The convergent validity of the measurement model using reflective indicators is assessed based on the *outer loading factor* of the indicators that measure the construct. In this study there are 5 constructs with a number of indicators ranging from 3 to 10 indicators with a scale of 1 to 5.

If the correlation coefficient is equal to 0.3 or more (at least 0.3) then the instrument is declared *valid*, and *invalid* if the correlation coefficient is smaller than 0.3 (Sugiyono, 2006) states based on the results of the *loading factor* above, it is concluded that the construct which has a dominant *loading factor* above 0.5 has a good *convergent validity*.

Validity test is also performed by testing methods comparing the value of the *square root of average variance extracted (AVE)* in each construct with the correlation between other constructs contained in the model.

Table 2 . Testing Results Table AVE

VARIABLES	Average Variance Extracted (AVE)
Product quality	0717
Buying decision	0.698
Repeat purchase	0.689

Source: Data processed from Smart PLS output

Composite Reliability and Cronbach’s Alpha

Besides the construct validity test, a construct reliability test is also measured by *composite reliability* and *Cronbach’s alpha* from the indicator block that measures the construct. The following are the results of testing the *reliability* and *cronbach’s alpha composite* from Smart PLS:

Table 2 . Composite Reliability and Cronbach’s Alpha tables

Variable	Cronbach’s Alpha	Composite Reliability
Product quality	0.920	0.938
Buying decision	0.913	0.933
Repeat purchase	0.925	0.939

Source: Data processed from Smart PLS output

The construct is declared reliable if it has a *composite reliability* value above 0.70 and *Cronbach’s alpha* above 0.60. From the results of *Smart PLS output* above all constructs have *composite reliability* values above 0.70.

The measurement model for the validity and reliability test, the coefficient of determination of the model and the path coefficient for the equation model, can be seen in the following figure

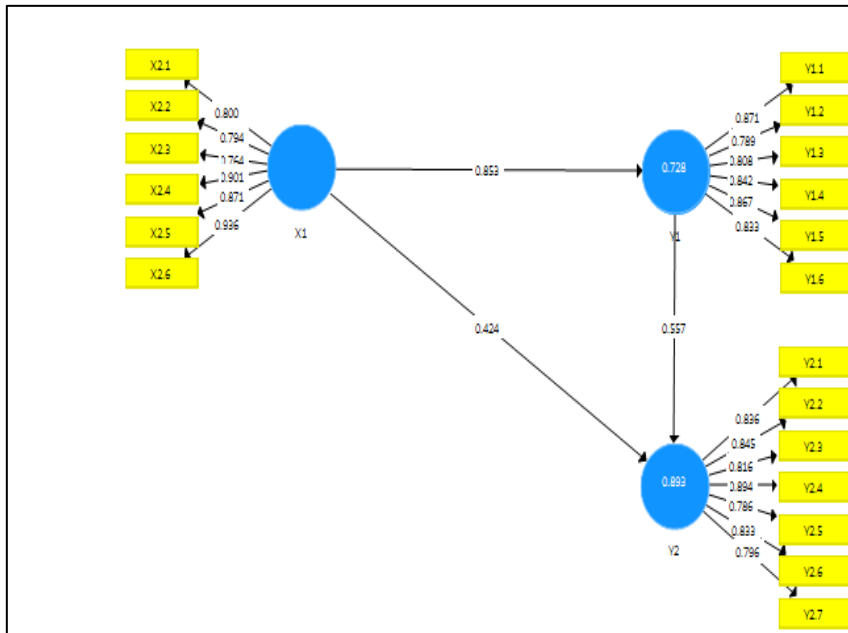

Figure 2. PLS Algorithm

Sumber: Source: Data processed from Smart PLS output

Structural Model Testing (Inner Model)

Structural model in PLS evaluated using R^2 for the dependent variable and the coefficient of the path for the independent variables were then assessed the significance based on the value of *t-statistic* of each path . The structural model of this research can be seen in the following figure:

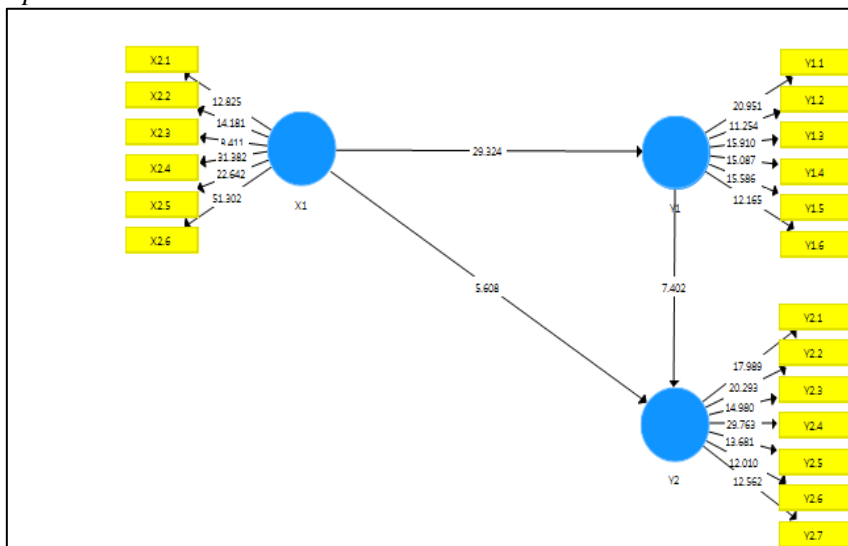

Figure 3. Display of PLS Bootstrapping Results

Source: Data processed from Smart PLS output

R2 values for each endogenous variable in this study can be seen in Table

Table 3. R-Square table

<i>Variable</i>	<i>R Square</i>	
	<i>R Square</i>	<i>Adjusted</i>
Purchase Decision (Y1)	0728	0725
Repurchase (Y2)	0.893	0890

Source: Data processed from Smart PLS output

R Square Value of Buying Decisions (Y1) of 0.728 shows a double correlation (process analysis and product quality) with purchase decision. And R Square Repurchase Value (Y1) of 0.893 shows a double correlation (process analysis, product quality and Purchase Decision)

Goodness of Fit

In the next stage the model evaluation will be carried out through *goodness of fit*. *Goodness of fit* assessment is known from the *Q-Square value*. Value *Q-Square* has the same meaning as the coefficient of determination (*R-Square*) in the regression analysis, where the higher the *Q-Square*, then the model can be said to be more fit to the data. The results of the calculation of the values of *Q-Square* are as follows:

$$\begin{aligned}
 Q\text{-Square} &= 1 - [(1-0,728) \times (1-0,893)] \\
 &= 1 - (0.272 \times 0.107) \\
 &= 1 - 0.029104 \\
 &= 0.97
 \end{aligned}$$

Based on the calculation above, the *Q-Square value* of 0.749 is obtained. This shows the amount of diversity of research data that can be explained by the research model is 97%, while the remaining 3% is explained by other factors that are outside this research model. Based on these results, the model in this study can be stated to have had an excellent *goodness of fit*.

Other variables or other factors that can influence Buying decisions include service quality and a significant positive effect on Buying decisions (Anggita, R., & Ali, H. 2017), brand trust has a positive and significant effect on Buying decisions Rizky, Muhammad, et. al (2015), brand equity has a positive and significant effect on Buying decisions Asih, Ratih Kartini (2013), etc.

Table 4 . Path Coefficients table (Mean, STDEV, t-Value)

<i>Variable</i>	<i>Original Sample (O)</i>	<i>T Statistics</i>	<i>P Values</i>	<i>Significance Level</i>
<i>Product Quality -> Buying Decisions</i>	0.853	29,324	0,000	<0.05
<i>Product Quality -> Repurchase</i>	0.424	5,608	0,000	< 0.05
<i>Purchase Decision -> Repurchase</i>	0.557	7402	0,000	<0.05

Source: Data processed from Smart PLS output

Based on the table above it can be seen that the measurement model formed is the Equation Model as below:

$$Y1 = 0.853X1$$

$$Y2 = 0.424X1 + 0.557Y1$$

Where,

X1 = Product Quality
Y1 = Buying Decision
Y2 = Repurchase

The equation above can be interpreted as follows:

1. Product Quality Variables have a positive direction coefficient on Buying Decisions
2. Product Quality Variables have a positive direction coefficient on Repeat purchases.
3. The Purchase Decision Variable has a positive coefficient direction on Repeat purchase.

Hypothesis testing

1) The Effect of Product Quality on Buying Decisions

The first hypothesis which states that Product Quality Influences Buying Decisions can be proven true. This can be seen from the statistical t value of 29,324 which is greater than the value of t table = 1.96, and the probability value of 0,000 which is smaller than the specified critical value limit of 0.05. Thus it is stated that Product Quality has a significant effect on Buying Decisions.

The durability dimension of the product quality variable (X2) has the strongest relationship with the dimensions of the number of purchases (Y1). This shows that the quality of the product influences customers to purchase mortgage products at Bank *Permata Syariah*.

The results of this study are in line with the results of research conducted by Deebhijarn, Samarat (2016), Fatlah (2013), Rahdini, Mentari et al (2014), Anggita, R (2017), Brata, B, H. (2017); Muhammad, A (2016), Yulasmi (2016) 2015), Karnawati, Tin Agustina, Siti Fatonah and Susanto, D (2017), Mariana (2017), Wijaya, Muslim (2016), Ismayanti (2018), Quansah, Fidelis (2015). Where the results of his research show if product quality has a positive and significant influence on Buying decisions.

2) The Effect of Product Quality on Repeat Purchases

The second hypothesis which states that Product Quality Influences Repurchase is proven true. This can be seen from the statistical t value of 5,608 which is greater than the value of t table = 1.96, and the probability value of 0,000 which is greater than the specified critical value limit of 0.05. Thus it is stated that Product Quality has no significant effect on Buying Decisions

Dimension of durability on the product quality variable (X2) has the strongest relationship with the dimensions of the number of purchases (Y2). This shows that the quality of the product influences customers to purchase mortgage products at Bank *Permata Syariah*.

The results of this study are in line with the results of research conducted by Deebhijarn, Samarat (2016), Fatlah (2013), Rahdini, Mentari et al (2014), Anggita, R (2017), Brata, B, H. (2017), Muhammad, A (2016), Yulasmi (2016) 2015), Karnawati, Tin Agustina, Siti Fatonah and Darmadi Susanto (2017), Mariana (2017), Wijaya, Muslim (2016), Ismayanti (2018), Quansah, Fidelis (2015). Where the results of his research show if product quality has a positive and significant influence on Buying decisions

3) The Influence of Buying Decisions Against Repeat Purchases

The third hypothesis which states that Buying Decisions have an Impact on Past Purchases can be proven true. This can be seen from the t value of statistics equal to 7.402 which is greater than the value of t table = 1.96, and the probability value of 0.000 which is smaller than the specified critical value limit of 0.05. Thus it is stated that the Purchase Decision has significant and significant effect on Repurchase

CONCLUSION AND SUGGESTION

Based on the results of research and discussion in the previous chapter, regarding the effect of products, prices, promotions, distribution and brand image on customer satisfaction can be concluded that:

1. The process of positive and significant effect on purchase. The dimension of timeliness of the process variable has a very strong relationship with the dimensions of the number of purchases on the purchase decision variable. This shows that the timeliness of the mortgage financing process will affect the purchase decision. While the dimension that has a very weak relationship is the initial step dimension gets with the channel selection dimension. This shows that the lack of initial information when customers need mortgage financing because it is caused by customer service that is still lacking. According to the results of the research other matters related to the process that need to be improved are the initial steps to obtain, ease of service and speed and timeliness.
2. Product Quality has a positive and significant effect on Buying Decisions. Dimension endurance (*durability*) in the variable quality of the products have the strongest association with the dimensions of the purchase amount. This shows that the quality of the product influences customers to purchase mortgage products at Bank *Permata Syariah*. While the dimensions that have a very weak relationship are between the dimensions of reliability of payment methods. This shows that the reliability of Sharia mortgage financing products that still need to be improved so that it affects the payments made by customers to pay installments. In accordance with the results of research other matters related to product quality that need to be improved are the form, features, reliability, ease of repair (*repairability*).
3. Product Process and Quality has a positive and significant effect on Buying decisions. Variable perception of the price, process and product quality influence on purchase decisions. This shows that if the price offered to the customer is appropriate and competitive enough so that the customer has a good perception of the price offered from KPR Bank *Permata Syariah*, then the KPR financing process is also fast and precise as well as expected and supported by the quality of the KPR financing product Bank *Permata Syariah*, then these things affect customers' decision to take mortgage financing at Bank *Permata Syariah*. The relationship of each free dimension to the dimensions of the purchase decision both a very weak relationship to a very strong relationship shows the influence of the variable perception of price, process, product quality, on the purchase decision

Suggestions

a. Practically

As for some of the things that researchers suggest for the next research are:

1. To get a comparison and strengthen the theory of the influence of the studied variables, it is necessary to do a review and re-study at different locations so that it is expected to strengthen the theory of the influence of the research variables.
2. As stated in the previous discussion, the variable perception of price, process and product quality has an effect of 73.9% on Buying decisions. This means that there are still 26.1%

which is another factor that influences the decision to purchase Sharia mortgage products at Bank *Permata Syariah* in the South Tangerang area. Further studies are needed by using or adding other indicators and can also use different concepts. Other variables or other factors that may influence Buying decisions include quality of service , , trust the brand , , brand equity and other factors. It is hoped that these other factors can be examined, so that the development of knowledge will continue to develop.

REFERENCE

- Ahmadi, A., Narbuko, C. (2009). *Metode Penelitian*. Bumi Aksara. Jakarta.
- Anggita, R., & Ali, H. (2017). The Influence of Product Quality, Service Quality and Price to Purchase Decision of SGM Bunda Milk (Study on PT. Sarihusada Generasi Mahardika Region Jakarta, South Tangerang District). *A (Multidisciplinary Journal)*
- Asker, D. A. (2013). *Manajemen Pemasaran Strategis*. Edisi kedelapan Salemba Empat. Jakarta
- Atikanit, Ratchadet, Visitnitikija, Chinnaso (2017). Marketing Mix Factors Influencing Consumer Buying Decision of Life Insurance from Commercial Bank. *International Conference on Literature, History, Humanities and Interdisciplinary Studies*. Pp. 29-31.
- Buchari Alma, (2008). *Manajemen Pemasaran dan Pemasaran Jasa*. Bandung : Alfabeta.
- Brata, B. H., Husani, S., & Ali, H. (2017). The Influence of Quality Products, Price, Promotion, and Location to Product Purchase Decision on Nitchi At PT. Jaya Swarasa Agung in Central Jakarta. *Saudi Journal of Business and Management Studies*, 2(4), 357-374. 4
- CHEN, Jian-na, et. al., (2017). Study on the Impact of Consumers' Willingness to Purchase Financial Products—Taking the Hangzhou branch of Guangfa Bank as an Example . *4th International Conference on Education Reform and Modern Management (ERMM 2017)*. Pp. 113-116.
- Ghezlbash, Shekoufeh (2017). Evaluating the Impact of Promotion Price, Product Quality, Service Quality, Customer Satisfaction and Repeating Purchase Incentives. *Journal of Internet Banking and Commerce*. vol. 22, no. S8. Pp. 1-17.
- Ghozali, Imam. (2011). *Aplikasi Analisis Multivariate Dengan Program SPSS*. Semarang, Edisi 5. BP UNDIP.
- Hartono, Bambang Dwi, et. al., (2017). Creating Purchase Decision of Bank Customers: Analysis of Product Quality, Place, Service Quality And Promotion (a Case Study on TAPLUS Bisnis Service of BNI Kelapa Dua Depok). *International Journal of Business and Management Invention*. Volume 6 Issue 2, pp. 65-75.
- Husaeni, Uus Ahmad. (2017). The Influence of Marketing Mix on Decision to be a Islamic Banking Customer in Cianjur Regency. *IQTISHADIA*. Vol.10 No. 2, pp. 105-119.
- Istiyanto Oei. (2010). *Riset Sumber Daya Manusia*. Gramedia Pustaka Utama, Jakarta
- Kotler, Philip & Armstrong, Gary (2012). *Prinsip-prinsip Pemasaran* Edisi 13, Jilid 1, Jakarta : Erlangga.
- Kotler, Philip . (2012). *Prinsip-prinsip Pemasaran* .Edisi Ketigabelas Jilid I. Erlangga. Jakarta.
- Kotler, Philip, Keller, L Kevin (2012). *Manajemen Pemasaran*. Edisi 12. Jakarta: Erlangga.
- Levy, Hagit, Shalev, Ron (2017). Bond repurchase objectives and the repurchase method choi. *Journal of Accounting and Economics*. 63 (2017) 385–403.
- Mursid, M. Drs.(2014). *Manajemen Pemasaran*. Jakarta: Bumi Aksara
- Ngadino S. Diposumarto dan Wihelmus H. Susilo, Riset Pemasaran, (2013), *Aplikasi Dengan SPSS, LISREL & AMOS Pada Penelitian Pemasaran Jasa*, In Media, Jakarta.
- Rahman, Arif. (2010). *Strategi Dahsyat Marketing Mix*. Trans Media Jakarta.
- Shofwa, Yoiz (2016). Pengaruh Kualitas Produk dan Religiusitas terhadap Keputusan Nasabah Produk Simpanan pada BSM Cabang Purwekerto. *Jurnal Ekonomi Islam (Islamic Economics Journal)*. Vol.4, No.1.PP 189-217
- Schiffman dan Kanuk. (2008). *Perilaku Konsumen*. Edisi 7. Jakarta. Indeks

- Sugiyono. (2011). *Metode Penelitian Pendidikan (Pendekatan Kuantitatif, Kualitatif dan R&D)*. Alfabeta. Bandung.
- Sugiyono. (2009). *Metode Penelitian Bisnis*. Alfabeta. Bandung.
- Tjiptono, Fandy. (2008). *Strategi pemasaran*. Edisi 3. ANDI: Yogyakarta
- Tjiptono, Fandy & Gregorius Chandra (2011). *Service, Quality & Satisfaction*. Edisi 3, Andi: Yogyakarta.
- Tjiptono, Fandy (2014). *Strategi pemasaran*. Edisi 4. ANDI: Yogyakarta
- Yazid, Ahmad Shukri, et. al., (2017). Does Education Moderates the Relationship Between Decision Factors and Purchase Decision of Family Takaful Protection in Malaysia?. *World Applied Sciences Journal*. 35 (9): 1849-1863.
- Yunita, D., & Ali, H. (2017). Model of Buying Decision (Renting) of Generator Set: Analysis of Product Quality, Price an Service at PT. HarteHouse Ownership Credit ima Listrindo. *Scholars Journal of Economics, Business and Management*, e-ISSN, 2348-5302.
- Agussalim, M., Ali,H. (2017). Model Kepuasan Pelanggan: Analisis Kualitas Produk Dan Kualitas Layanan Terhadap Citra Merek Pada Giant Citra Raya Jakarta. *Jurnal Manajemen* 21 (3), 317-335.
- Zeithaml. V.A., M.J.Bitner, DD. Gremler. (2013). *Services Marketing: Integrating Customer Focus Across the Firm*. the 6 edition. Mc.Graw-Hill. Boston
- Zhu, Jie, et. al., (2016). The Factors Influencing the ReBuying Intention of Bank Insurance in Taiwan. *2nd International Conference on Economy, Management, Law and Education (EMLE 2016)*. Vol. 20. Pp 110-114.
- Majalah Infobank, (2018). *Edisi Khusus Syariah 2018 Infobank Analisis Strategi Perbankan dan Keuangan* No. 482 Vol.XL
- Website Otoritas Jasa Keuangan (OJK), 2018, [http://www. Ojk.go.id/id/kanal/syariah/data-dan-statistik/statistik-perbankan-syariah](http://www.Ojk.go.id/id/kanal/syariah/data-dan-statistik/statistik-perbankan-syariah)
- Website Bank Permata, 2018, <http://www.permatabank.com>
- Buku Laporan Tahunan, 2016, Annual Report Bank Permata.