



Model of dissipative dielectric elastomers

Choon Chiang Foo, Shengqiang Cai, Soo Jin Adrian Koh, Siegfried Bauer, and Zhigang Suo

Citation: *J. Appl. Phys.* **111**, 034102 (2012); doi: 10.1063/1.3680878

View online: <http://dx.doi.org/10.1063/1.3680878>

View Table of Contents: <http://jap.aip.org/resource/1/JAPIAU/v111/i3>

Published by the [American Institute of Physics](#).

Related Articles

Dynamics of solvent-free grafted nanoparticles

J. Chem. Phys. **136**, 044902 (2012)

Energy transfer and dynamics studies of photoluminescence of polythiophene derivative in blend thin films

J. Appl. Phys. **111**, 023512 (2012)

Note: Percolation in two-dimensional flexible chains systems

J. Chem. Phys. **136**, 046101 (2012)

Ultraviolet and infrared femtosecond laser induced periodic surface structures on thin polymer films

Appl. Phys. Lett. **100**, 041106 (2012)

Different growth regimes on prepatterned surfaces: Consistent evidence from simulations and experiments

J. Chem. Phys. **136**, 024704 (2012)

Additional information on *J. Appl. Phys.*

Journal Homepage: <http://jap.aip.org/>

Journal Information: http://jap.aip.org/about/about_the_journal

Top downloads: http://jap.aip.org/features/most_downloaded

Information for Authors: <http://jap.aip.org/authors>

ADVERTISEMENT



Model of dissipative dielectric elastomers

Choon Chiang Foo,^{1,2} Shengqiang Cai,¹ Soo Jin Adrian Koh,^{2,3} Siegfried Bauer,⁴ and Zhigang Suo^{1,a)}

¹*School of Engineering and Applied Sciences, Kavli Institute for Nanobio Science and Technology, Harvard University, Cambridge, Massachusetts 02138, USA*

²*Institute of High Performance Computing, 1 Fusionopolis Way, #16-16 Connexis, Singapore 138632, Singapore*

³*Engineering Science Programme and Department of Civil and Environmental Engineering, National University of Singapore, Kent Ridge, Singapore 119260, Singapore*

⁴*Soft-Matter Physics Department, Johannes Kepler University Linz, A-4040 Linz, Austria*

(Received 17 October 2011; accepted 17 December 2011; published online 3 February 2012)

The dynamic performance of dielectric elastomer transducers and their capability of electromechanical energy conversion are affected by dissipative processes, such as viscoelasticity, dielectric relaxation, and current leakage. This paper describes a method to construct a model of dissipative dielectric elastomers on the basis of nonequilibrium thermodynamics. We characterize the state of the dielectric elastomer with kinematic variables through which external loads do work, and internal variables that measure the progress of the dissipative processes. The method is illustrated with examples motivated by existing experiments of polyacrylate very-high-bond dielectric elastomers. This model predicts the dynamic response of the dielectric elastomer and the leakage current behavior. We show that current leakage can be significant under large deformation and for long durations. Furthermore, current leakage can result in significant hysteresis for dielectric elastomers under cyclic voltage. © 2012 American Institute of Physics. [doi:10.1063/1.3680878]

I. INTRODUCTION

A dielectric elastomer transducer consists of a thin membrane of the elastomer, sandwiched between two compliant electrodes (Fig. 1(a)). The electrodes are connected to a power source through a conducting wire. Subject to a voltage, the electric current in the conducting wire partly leaks through the membrane, and partly adds charges to the electrodes (Fig. 1(b)). The opposite charges on the electrodes polarize the dielectric. Attractive electrostatic forces between the opposite charges reduce thickness and expand area of the membrane—the dielectric elastomer performs as an actuator.^{1,2} On the other hand, when a pre-stretched and pre-charged membrane is mechanically relaxed in the open-circuit condition, the membrane boosts the voltage between the electrodes—the dielectric elastomer performs as a generator.

As a result of their fast response time and high energy density, dielectric elastomers (DEs) have been developed as artificial muscles, Braille displays, life-like robots, tunable lens, and power generators.^{3–9} To perform as an actuator and a generator, a dielectric elastomer is often subject to transient, time-dependent forces and voltages.^{9–13} The performance will therefore be affected by mechanisms of dissipation in the system.^{13–15} In particular, experiments have shown that viscoelasticity and current leakage can adversely affect the performance of a transducer and limit its application.^{9,11–17} This paper presents a model that incorporates the major dissipative mechanisms in dielectric elastomers, so as to predict how these dissipative processes affect the performance of dielectric elastomer transducers.

The state of equilibrium of a dielectric elastomer transducer is described by four types of variables: force, displacement, voltage and charge. One may choose to vary any two of the four variables independently, with the other two variables determined by the material properties. Therefore, the transducer is an electromechanical system with two degrees of freedom. For instance, one may choose to vary the force and voltage as inputs to the transducer. Subject to a mechanical force and voltage, the transducer takes time to equilibrate to its state of kinematic deformation and charge polarization. This process is known as relaxation.

Subject to a mechanical force, a dielectric elastomer relaxes to a new state of deformation over a characteristic time, known as the viscoelastic relaxation time, τ_V . An elastomer consists of a network of polymer chains (Fig. 2(a)). Each polymer chain is connected to other polymer chains at specific points, by covalent crosslinks, forming a network. A sufficiently flexible polymer chain may twist and coil, and entangle with other chains. When a force is applied to the elastomer, localized slipping and sliding of polymer chains occur. Viscoelastic relaxation is a consequence of entangled polymer chains responding to a force. Experiments have shown that for polyacrylate very-high-bond (VHB) elastomer, which is a commercial tape from 3M, τ_V is on the order of 10^2 seconds at room temperature.^{16,18–20}

Subject to a voltage, the dielectric elastomer relaxes to a new state of polarization over a characteristic time, known as the dielectric relaxation time, τ_d . Dielectric relaxation is the process of re-orientation of molecular dipoles in a polar dielectric (Fig. 2(b)). The re-alignment is on the molecular scale. The dielectric relaxation time τ_d strongly depends on temperature, especially in the vicinity of the glass transition. On the basis of experiments on polymer dielectrics,^{21,22} we

^{a)}Author to whom correspondence should be addressed. Electronic mail: suo@seas.harvard.edu.

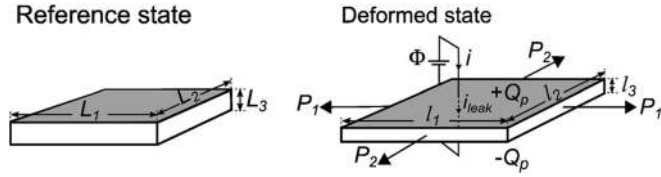

FIG. 1. In the reference state, a membrane of a dielectric elastomer is undeformed, and has dimensions L_1 , L_2 , and L_3 . In the deformed state, subject to forces P_1 and P_2 , as well as voltage Φ , the membrane attains dimensions l_1 , l_2 , and l_3 . The elastomer is viscoelastic and is an imperfect insulator. The current i in the conducting wire partly charges the electrodes, and partly leaks through the membrane.

assume that τ_d is on the order of 10^{-6} seconds at room temperature for dielectric elastomers in the rubbery state.

The relaxation processes mentioned above involve localized translation and rotation of single molecules, a group of molecules, or molecular chains. We next describe a nonequilibrium process that involves long-range transport through the dielectric (Fig. 3). When a dielectric is connected to a power source, a small current may flow through the dielectric. This process is known as current leakage, which is well documented in several insulator and semi-conductor systems.^{17,23–27} The occurrence of leakage current is a result of the transport of electrons, ions, or both,^{23–25} and is often linked to the presence of impurities and imperfections.^{23,24} In the simplest case, the leakage current density varies approximately linearly with the applied field for small electric fields (< 10 MV/m), known as the Ohmic conduction.

As the electric field increases, the leakage current strongly increases; in commonly used models an exponential increase with the electric field is assumed,^{17,26} approaching electrical breakdown. Electrical conduction does not follow Ohm's Law (non-Ohmic). The switch from Ohmic to non-Ohmic conduction is used as a precursor to indicate imminent electrical breakdown.¹⁵ Continued operation within the non-Ohmic regime may also lead to severe deterioration of the insulating properties of the dielectric.^{28–32}

In this paper, we investigate the effects of dissipative processes on the electromechanical conversion performance of a dielectric elastomer. In particular, we develop a model that includes both local and long-range dissipation in the dielectric elastomer within a nonequilibrium thermodynamics framework. To illustrate our approach, we construct a specific model for viscoelastic dielectric elastomer and

define a current leakage density based on empirical observations. In our analysis, we assume that the dielectric elastomer has a dielectric relaxation time in the order of 10^{-6} s, and that the time scale of operation is in the order of seconds. Hence, dielectric relaxation will be ignored in our analyses. Nevertheless, our framework allows dielectric relaxation to be included for systems where the effect cannot be ignored. Finally we provide examples to show how viscoelasticity and current leakage affect the performance of a dielectric elastomer.

II. THERMODYNAMICS OF DISSIPATIVE PROCESSES

This section describes a thermodynamic model of dissipative dielectric elastomers. To focus on main ideas, the presentation of this section is restricted to a membrane of a dielectric elastomer undergoing homogeneous deformation. The same model is presented in a general form, in the Appendix, for a body of a dielectric elastomer undergoing inhomogeneous deformation.

Figure 1 illustrates the operation of a dielectric elastomer transducer. A membrane of a dielectric elastomer is sandwiched between two electrodes of negligible electrical resistance and mechanical stiffness compared to those of the membrane. In the reference state, the membrane is undeformed and is of dimensions L_1 , L_2 , and L_3 . In the deformed state, the membrane is subject to forces P_1 and P_2 , and the two electrodes connected through a conducting wire to a power source of voltage Φ , while the dimensions of the membrane are l_1 , l_2 , and l_3 . The forces, voltage, and dimensions are time dependent.

The charge moving in the conducting wire, δQ , partly leaks through the membrane, δQ_{leak} , and partly accumulates on the electrodes to polarize the membrane. The amount of polarizing charge on either electrode changes from Q_p to $Q_p + \delta Q_p$. The conservation of charge requires that,

$$\delta Q = \delta Q_p + \delta Q_{leak}. \quad (1)$$

We shall restrict our analysis to isothermal processes. Let the Helmholtz free energy of the membrane be F . Associated with small changes in the dimensions of the membrane, δl_1 , δl_2 , and δl_3 , the forces do work $P_1 \delta l_1 + P_2 \delta l_2$. Associated with a small amount of charge moving through the conducting wire, δQ , the voltage does work $\Phi \delta Q$. Thermodynamics

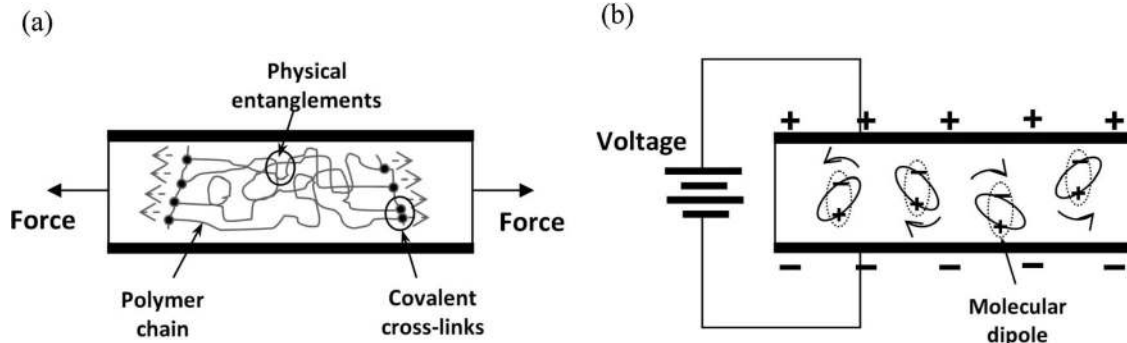

FIG. 2. Schematics of local dissipative processes: (a) viscoelastic relaxation due to sliding of polymer chains; (b) dielectric relaxation due to re-orientation of dipoles along the direction of the applied electric field.

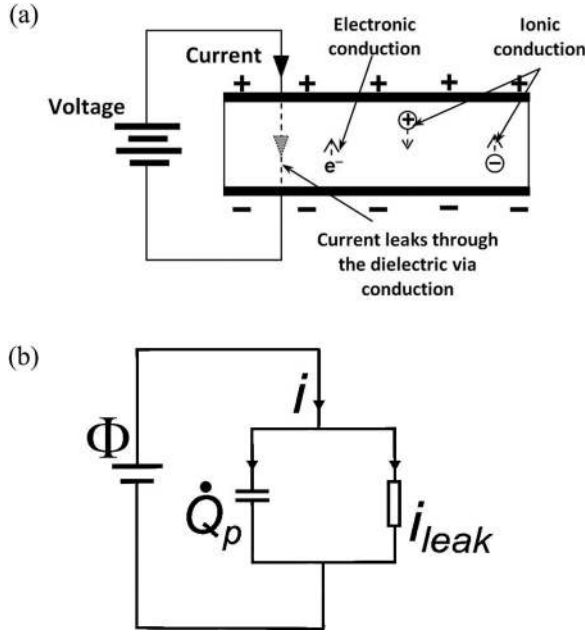

FIG. 3. (a) Schematics of current leakage through the dielectric: charge transport is due to the movement of electrons (e^-) and ions ($+/-$) under an applied electric field. (b) To model current leakage, the dielectric elastomer is considered as a capacitor with a resistor in parallel. By the principle of charge conservation, the current consumed by the battery i is the sum of the charge flow rate to the capacitor \dot{Q}_p and the current leakage through the resistor i_{leak} .

dictates that the increase in the free energy should not exceed the combined work done by the forces and voltage,

$$\delta F \leq P_1 \delta l_1 + P_2 \delta l_2 + \Phi \delta Q. \quad (2)$$

The equality holds when the membrane undergoes quasi-equilibrium processes. The inequality holds when the membrane undergoes nonequilibrium processes. For the inequality to be meaningful, the small changes are time directed: δf means the change of the quantity f from one time to a slightly later time.

The thermodynamic inequality (2) should hold for every dissipative process in the membrane. As discussed before, the dissipative processes in the membrane may be classified into two types. The leakage current involves long-range transport of charges, while viscoelasticity and dielectric relaxation involve local molecular movements. The two types of processes are separately dissipative. Thus, thermodynamics requires that,

$$\Phi \delta Q_{leak} \geq 0. \quad (3)$$

This inequality is readily understood: the charge leaks through the membrane in the direction from the high-potential electrode to the low-potential electrode. Furthermore, viscoelastic and dielectric relaxation are dissipative, so that,

$$\delta F \leq P_1 \delta l_1 + P_2 \delta l_2 + \Phi \delta Q_p. \quad (4)$$

The last term represents the work done by the polarizing charge on the electrodes.

The density of the Helmholtz free energy is defined as $W = F/(L_1 L_2 L_3)$. The stretches of the elastomer in the three directions are defined by $\lambda_1 = l_1/L_1$, $\lambda_2 = l_2/L_2$, and $\lambda_3 = l_3/L_3$. The stresses are defined by $\sigma_1 = P_1/(l_2 l_3)$ and $\sigma_2 = P_2/(l_1 l_3)$. The electric field is $E = \Phi/l_3$, and the electric displacement is defined by $D = Q_p/(l_1 l_2)$. By definition, the amount of polarizing charge accumulated on either electrode is $Q_p = D l_1 l_2$. Associated with small changes in the dimensions of the membrane and the electric displacement, the polarizing charge changes by $\delta Q_p = D l_1 \delta l_2 + D l_2 \delta l_1 + l_1 l_2 \delta D$. Inserting this expression into (4), and dividing the resulting inequality by the volume of the undeformed membrane, $L_1 L_2 L_3$, we obtain that,

$$\begin{aligned} \delta W \leq & (\sigma_1 + ED) \lambda_2 \lambda_3 \delta \lambda_1 + (\sigma_2 + ED) \lambda_1 \lambda_3 \delta \lambda_2 \\ & + \lambda_1 \lambda_2 \lambda_3 E \delta D. \end{aligned} \quad (5)$$

The elastomer is assumed to be incompressible, so that $\lambda_1 \lambda_2 \lambda_3 = 1$. We will use λ_1 and λ_2 as independent variables, and calculate λ_3 from $\lambda_3 = (\lambda_1 \lambda_2)^{-1}$. The density of the Helmholtz free energy is assumed to be a function of a set of independent variables,

$$W = W(\lambda_1, \lambda_2, D, \xi_\alpha, \xi_\beta, \dots). \quad (6)$$

Here $\xi_\alpha, \xi_\beta, \dots$ represent a set of internal variables that characterize the progress of dissipative processes in the membrane. In particular, $\xi_\alpha, \xi_\beta, \dots$ can represent the progress of viscoelastic and dielectric relaxation. Associated with small changes in the independent variables, the density of the Helmholtz free energy changes by,

$$\delta W = \frac{\partial W}{\partial \lambda_1} \delta \lambda_1 + \frac{\partial W}{\partial \lambda_2} \delta \lambda_2 + \frac{\partial W}{\partial D} \delta D + \sum_\gamma \frac{\partial W}{\partial \xi_\gamma} \delta \xi_\gamma. \quad (7)$$

A combination of (5) and (7) gives that,

$$\begin{aligned} & \left(\frac{\partial W}{\partial \lambda_1} - (\sigma_1 + ED) \lambda_2 \lambda_3 \right) \delta \lambda_1 + \left(\frac{\partial W}{\partial \lambda_2} - (\sigma_2 + ED) \lambda_1 \lambda_3 \right) \delta \lambda_2 \\ & + \left(\frac{\partial W}{\partial D} - E \right) \delta D + \sum_\gamma \frac{\partial W}{\partial \xi_\gamma} \delta \xi_\gamma \leq 0. \end{aligned} \quad (8)$$

This inequality can be satisfied in many ways. We adopt the following assumptions. The membrane is in mechanical and electrostatic equilibrium, so that the coefficients in front of $\delta \lambda_1$, $\delta \lambda_2$, and δD vanish, giving,

$$\sigma_1 + ED = \lambda_1 \frac{\partial W(\lambda_1, \lambda_2, D, \xi_\alpha, \xi_\beta, \dots)}{\partial \lambda_1}, \quad (9)$$

$$\sigma_2 + ED = \lambda_2 \frac{\partial W(\lambda_1, \lambda_2, D, \xi_\alpha, \xi_\beta, \dots)}{\partial \lambda_2}, \quad (10)$$

$$E = \frac{\partial W(\lambda_1, \lambda_2, D, \xi_\alpha, \xi_\beta, \dots)}{\partial D}. \quad (11)$$

The membrane, however, is not in equilibrium with respect to viscoelastic and dielectric relaxation, so that,

$$\sum_\gamma \frac{\partial W(\lambda_1, \lambda_2, D, \xi_\alpha, \xi_\beta, \dots)}{\partial \xi_\gamma} \delta \xi_\gamma \leq 0. \quad (12)$$

Inequality (12) places a restriction on viscoelastic models, and its effect will become evident when a rheological model is specified.

III. IDEAL DIELECTRIC ELASTOMERS

Both viscoelasticity and dielectric relaxation are due to local movements of molecules, or a group of molecules (Ref. 34) (Fig. 2). Although the rotation of the dipoles may cause deformation in the elastomer, we assume that this deformation is negligible compared to that caused by stretching of the long polymer chains. For commonly used dielectrics like VHB and silicone, at room temperature and pressure, the dielectric relaxation time is orders of magnitude smaller than the viscoelastic relaxation time.^{21,22} Furthermore, the typical time scale of operation of dielectric elastomers is in the region of seconds, where dielectric relaxation has long taken place. Hence, we will neglect dielectric relaxation in our analyses.

An elastomer is a network of polymer chains cross-linked by covalent bonds. Each chain consists of a large number of monomers. As a result, the crosslinks have a negligible effect on the process of polarization of these monomers—that is, the elastomer polarizes nearly like a polymer melt. This picture is supported by experiments,³⁵ which show that the permittivity of the elastomer changes insignificantly over a strain of 400%. We adopt the model of ideal dielectric elastomer,³⁶ assuming that the polarization behavior is liquid-like and independent of the state of deformation. That is, the electric displacement is taken to be linear in the electric field,

$$D = \varepsilon E, \quad (13)$$

where ε is the permittivity independent of deformation.

Inserting (13) into (11) and integrating, we obtain that

$$W(\lambda_1, \lambda_2, D, \xi_\alpha, \xi_\beta, \dots) = W_{stretch}(\lambda_1, \lambda_2, \xi_\alpha, \xi_\beta, \dots) + \frac{D^2}{2\varepsilon}. \quad (14)$$

Here $W_{stretch}$ is the Helmholtz free energy associated with the stretching of the elastomer. In the model of ideal dielectric elastomers, the stretching and polarization of the elastomer contribute to the free energy independently.

Inserting (14) into (9) and (10), we obtain that,

$$\sigma_1 + \varepsilon E^2 = \lambda_1 \frac{\partial W_{stretch}(\lambda_1, \lambda_2, \xi_\alpha, \xi_\beta, \dots)}{\partial \lambda_1}, \quad (15)$$

$$\sigma_2 + \varepsilon E^2 = \lambda_2 \frac{\partial W_{stretch}(\lambda_1, \lambda_2, \xi_\alpha, \xi_\beta, \dots)}{\partial \lambda_2}. \quad (16)$$

$$\sigma_1 + \varepsilon E^2 = \frac{\mu^\alpha(\lambda_1^2 - \lambda_1^{-2}\lambda_2^{-2})}{1 - (\lambda_1^2 + \lambda_2^2 + \lambda_1^{-2}\lambda_2^{-2} - 3)/J_{lim}^\alpha} + \frac{\mu^\beta(\lambda_1^2\xi_1^{-2} - \xi_1^2\xi_2^2\lambda_1^{-2}\lambda_2^{-2})}{1 - (\lambda_1^2\xi_1^{-2} + \lambda_2^2\xi_2^{-2} + \xi_1^2\xi_2^2\lambda_1^{-2}\lambda_2^{-2} - 3)/J_{lim}^\beta}, \quad (19)$$

$$\sigma_2 + \varepsilon E^2 = \frac{\mu^\alpha(\lambda_2^2 - \lambda_1^{-2}\lambda_2^{-2})}{1 - (\lambda_1^2 + \lambda_2^2 + \lambda_1^{-2}\lambda_2^{-2} - 3)/J_{lim}^\alpha} + \frac{\mu^\beta(\lambda_2^2\xi_2^{-2} - \xi_1^2\xi_2^2\lambda_1^{-2}\lambda_2^{-2})}{1 - (\lambda_1^2\xi_1^{-2} + \lambda_2^2\xi_2^{-2} + \xi_1^2\xi_2^2\lambda_1^{-2}\lambda_2^{-2} - 3)/J_{lim}^\beta}. \quad (20)$$

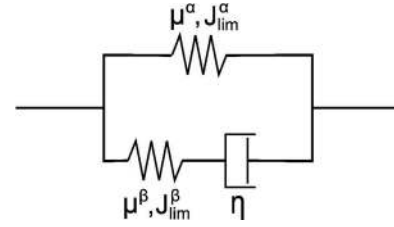

FIG. 4. Viscoelastic relaxation is modeled using two parallel units. One unit consists of spring α , and the other unit consists of spring β and a dashpot.

These relations confirm a widely used description of electro-mechanical interaction: The voltage produces a Maxwell stress of εE^2 .¹

IV. MODEL OF VISCOELASTICITY

Viscoelastic relaxation may be represented by a rheological model of springs and dashpots. We adopt a rheological model of two parallel units: one unit consists of a spring, α , and the other unit consists of another spring, β , and a dashpot (Fig. 4). As discussed before, the deformation of the elastomer is represented by two stretches, λ_1 and λ_2 . In the rheological model, λ_1 and λ_2 are assumed to be the net stretches of both units. For spring α , the state of deformation is characterized by stretches λ_1 and λ_2 . For spring β , however, the state of deformation is characterized by different stretches, which we designate as λ_1^e and λ_2^e . Let ξ_1 and ξ_2 be the stretches in the dashpot. We adopt the multiplication rule,^{20,37,38}

$$\lambda_1 = \lambda_1^e \xi_1, \lambda_2 = \lambda_2^e \xi_2. \quad (17)$$

Upon approaching a limiting stretch as a result of the finite contour length of the polymer chains, the dielectric elastomer shows pronounced stress-stiffening. To account for the effect of stress-stiffening, we represent both springs by using the Gent model.³⁹ The free-energy function of the elastomer is the sum of the contributions from the two springs:

$$W_{stretch} = -\frac{\mu^\alpha J_{lim}^\alpha}{2} \log \left(1 - \frac{\lambda_1^2 + \lambda_2^2 + \lambda_1^{-2}\lambda_2^{-2} - 3}{J_{lim}^\alpha} \right) - \frac{\mu^\beta J_{lim}^\beta}{2} \log \left(1 - \frac{\lambda_1^2 \xi_1^{-2} + \lambda_2^2 \xi_2^{-2} + \lambda_1^{-2}\lambda_2^{-2} \xi_1^2 \xi_2^2 - 3}{J_{lim}^\beta} \right), \quad (18)$$

where μ^α and μ^β are shear moduli of the two springs, and J_{lim}^α and J_{lim}^β are constants related to the limiting stretches of the two springs.

Inserting (18) into (15) and (16), we obtain that,

The two terms in the right-hand side of the above equations are the stresses carried by the two springs in the rheological model.

We model the dashpot as a Newtonian fluid. In the rheological model, the state of stress in the dashpot is the same as that in spring β . This state of stress is characterized by the

$$\frac{d\xi_1}{\xi_1 dt} = \frac{1}{3\eta} \left(\frac{\mu^\beta(\lambda_1^2 \xi_1^{-2} - \xi_1^2 \xi_2^2 \lambda_1^{-2} \lambda_2^{-2})}{1 - (\lambda_1^2 \xi_1^{-2} + \lambda_2^2 \xi_2^{-2} + \xi_1^2 \xi_2^2 \lambda_1^{-2} \lambda_2^{-2} - 3)/J_{\text{lim}}^\beta} - \frac{\mu^\beta(\lambda_2^2 \xi_2^{-2} - \xi_1^2 \xi_2^2 \lambda_1^{-2} \lambda_2^{-2})/2}{1 - (\lambda_1^2 \xi_1^{-2} + \lambda_2^2 \xi_2^{-2} + \xi_1^2 \xi_2^2 \lambda_1^{-2} \lambda_2^{-2} - 3)/J_{\text{lim}}^\beta} \right), \quad (21)$$

$$\frac{d\xi_2}{\xi_2 dt} = \frac{1}{3\eta} \left(\frac{\mu^\beta(\lambda_2^2 \xi_2^{-2} - \xi_1^2 \xi_2^2 \lambda_1^{-2} \lambda_2^{-2})}{1 - (\lambda_1^2 \xi_1^{-2} + \lambda_2^2 \xi_2^{-2} + \xi_1^2 \xi_2^2 \lambda_1^{-2} \lambda_2^{-2} - 3)/J_{\text{lim}}^\beta} - \frac{\mu^\beta(\lambda_1^2 \xi_1^{-2} - \xi_1^2 \xi_2^2 \lambda_1^{-2} \lambda_2^{-2})/2}{1 - (\lambda_1^2 \xi_1^{-2} + \lambda_2^2 \xi_2^{-2} + \xi_1^2 \xi_2^2 \lambda_1^{-2} \lambda_2^{-2} - 3)/J_{\text{lim}}^\beta} \right), \quad (22)$$

where η is the viscosity of the dashpot. So long as $\eta > 0$, this kinetic model satisfies the thermodynamic inequality (12).

The viscoelastic relaxation time is defined by using the viscosity of the dashpot and the modulus of spring β ,

$$\tau_V = \eta/\mu^\beta. \quad (23)$$

In reality, the elastomer may possess multiple relaxation times. This behavior may be incorporated in the model by introducing more parallel units of springs and dashpots.

Differentiating (19) and (20) with respect to time, and combining with (21) and (22), we obtain a set of four ordinary differential equations that evolve $\lambda_1(t)$, $\lambda_2(t)$, $\xi_1(t)$, and $\xi_2(t)$, once a program of loading is prescribed as functions $\sigma_1(t)$, $\sigma_2(t)$, and $E(t)$.

We fit this viscoelastic model to uniaxial tensile tests conducted on VHB at several stretching rates.¹⁰ Fig. 5(a) shows good agreement between the model and the experiment. The experimental data obtained at three stretching rates can be fit to the model by using a common set of parameters: $\mu^\alpha = 18$ kPa, $\mu^\beta = 42$ kPa, $\tau_V = 400$ s, $J_{\text{lim}}^\alpha = 110$ and $J_{\text{lim}}^\beta = 55$. The shear moduli and relaxation time compare reasonably well with those reported elsewhere.^{10,20} The Gent model captures the strain-stiffening effect.

V. MODEL OF LEAKAGE CURRENT

Divide (1) by the change in time, and we write,

$$i = \frac{dQ_p}{dt} + i_{\text{leak}}. \quad (24)$$

Here $i = dQ/dt$ is the current in the conducting wire, dQ_p/dt is the rate of change of the polarizing charge accumulated on the electrodes, and $i_{\text{leak}} = dQ_{\text{leak}}/dt$ is the current leaking through the membrane. As illustrated in Fig. 3(b), the conservation of charge requires that current in the conducting wire should equal the sum of the rate of change of the polarizing charge on the electrodes and the current leaking through the membrane.

Electrical conduction in polymers is a complex phenomenon, which may depend on the molecular configuration, defects and impurities in the structure, and the type of

two components given as the last term in (19) and the last term in (20). The rate of deformation in the dashpot is described by the two components $\xi_1^{-1} d\xi_1/dt$ and $\xi_2^{-1} d\xi_2/dt$. To model the dashpot as a Newtonian fluid, we relate the rate of deformation to the stress as,

electrodes, as well as temperature and moisture.^{23–25} Developing a model to capture these effects is beyond the scope of this paper. Instead, we propose a model based on following empirical observations. When the electric field is small, the leakage current is predominantly Ohmic and the leakage current density is approximately linear with the electric

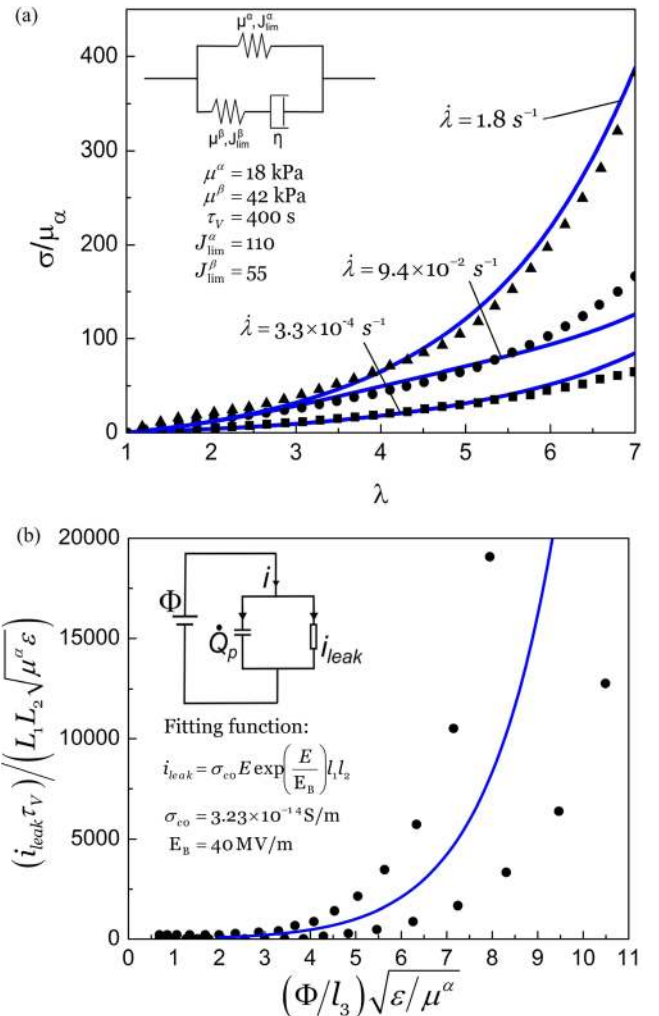

FIG. 5. (Color online) (a) Viscoelastic model is fitted to experimental data of Plante and Dubowsky.¹⁰ (b) Model of leakage current is fitted to experimental data of Gisby *et al.*¹⁷

field.^{24,26} As the electric field increases, the leakage current becomes non-Ohmic and increases exponentially.^{17,26} This non-Ohmic behavior becomes significant beyond a critical electric field, which is on the order of 10 MV/m.^{17,26,28} Recent experiments have reported that the conductivity for VHB 4910 increases exponentially under increasing electric field.²⁶

Define the density of the leakage current as $j_{leak} = i_{leak}/(l_1 l_2)$. Based on the above observations, we relate the density of leakage current to the electric field as,

$$j_{leak} = \sigma_c(E)E. \quad (25)$$

The conductivity $\sigma_c(E)$ is taken to depend only on the electric field E but not on deformation. So long as $\sigma_c(E) > 0$, this kinetic model satisfies the thermodynamic inequality (3). We adopt the exponential function,

$$\sigma_c(E) = \sigma_0 \exp\left(\frac{E}{E_B}\right). \quad (26)$$

where σ_0 is the conductivity at low field, and E_B is an empirical constant with the same dimension as the electric field. When $E \ll E_B$, the elastomer approximates an Ohmic conductor, that is, $j_{leak} \approx \sigma_0 E$. As $E \rightarrow E_B$, the conductivity increases exponentially.²⁶

The resistor-capacitor (RC) time constant is defined by the ratio between the permittivity and the conductivity of the dielectric,

$$\tau_{RC} = \varepsilon/\sigma_{c0}. \quad (27)$$

In Fig. 5(b), we fit the model of leakage current to experiments conducted on VHB 4905 actuators.¹⁷ The experiment

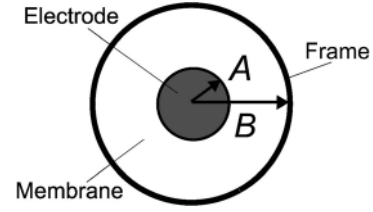

FIG. 6. Schematic of a circular actuator with electrodes coated on part of the surface of the elastomer.

confirms the exponential increase in leakage current at high electric fields. The fitting parameters are found to be $\sigma_{c0} = 3.23 \times 10^{-14}$ S/m, $E_B = 40$ MV/m and $\tau_{RC} = 1230$ s. The permittivity of the membrane is taken to be 3.98×10^{-11} F/m.¹⁰ Furthermore, the experimental data show significant scatter, especially at high fields. This indicates significant uncertainty in leakage current in the non-Ohmic region. This uncertainty may be due to the varying quality of the films produced,¹⁷ which contributes to the complex physical nature of current leakage. We select two sets of experimental data that bounds the maximum- and minimum-observed leakage current over the range of measured electric fields. Our fitting shows qualitative agreement with the experimental data.

VI. ELECTROMECHANICAL BEHAVIOR OF DISSIPATIVE DIELECTRIC ELASTOMERS

We now use the model of dissipative dielectric elastomers to simulate situations motivated by several recent experiments.^{14,26,40} These experiments were conducted by using the setup of circular actuators (Fig. 6). A membrane of a dielectric elastomer is pre-stretched and fixed to a rigid

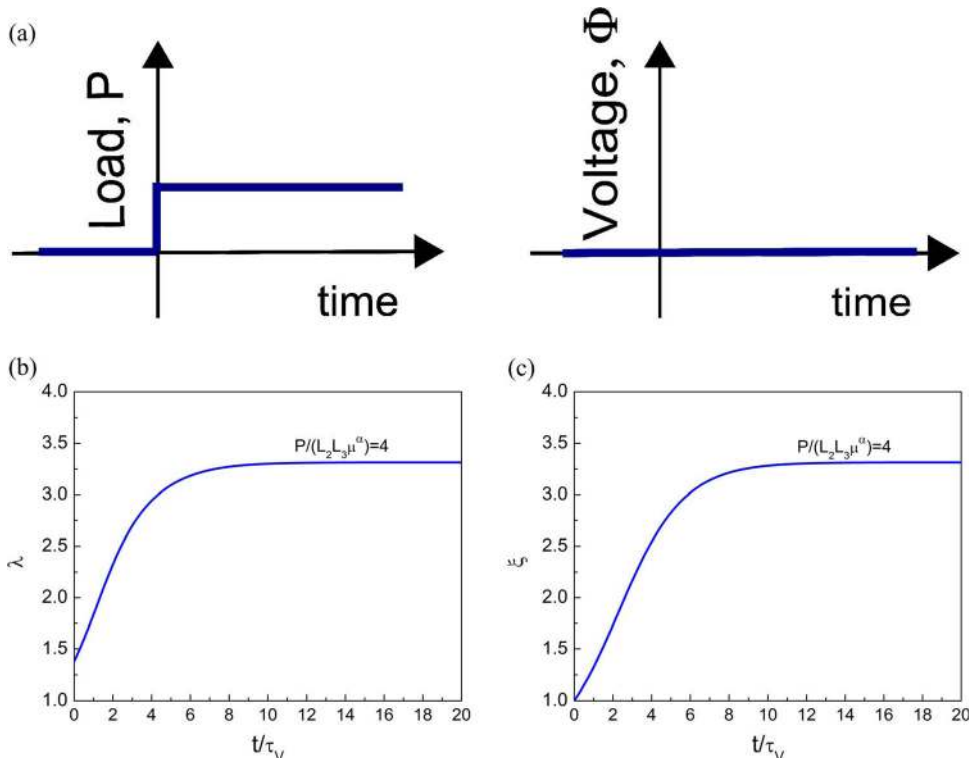

FIG. 7. (Color online) Under (a) constant mechanical load with no voltage, (b) the stretch of the membrane and (c) the stretch due to the dashpot, creep in time.

frame. On part or on the entire surface of the membrane compliant electrodes are applied. The membrane is then left to relax for a long time. Subsequently, voltage or current is applied as a function of time. In our analyses, we assume that the membrane is subject to homogeneous, equal-biaxial deformation. Hence, $\lambda_1 = \lambda_2 = \lambda$, $\xi_1 = \xi_2 = \xi$ and $\sigma_1 = \sigma_2 = \sigma$. We focus on two dissipative mechanisms in our simulations—viscoelasticity and current leakage. We first model two experiments that study each effect in isolation, followed by experiments on actuation and voltage cycling.

To study the effect of viscoelastic relaxation in isolation, we model a creep experiment of a viscoelastic elastomer (Fig. 7). In this experiment, a force P is applied at time $t = 0$. Subsequently, the magnitude of the force is fixed, while the membrane creeps in time. In a short time, the dashpot does not deform, and the load is carried by both springs. In a long time, the dashpot deforms and the load is carried by the spring α alone. The characteristic time scale in this process is the viscoelastic relaxation time, τ_V .

Next, we study the effect of current leakage in isolation. Our simulation was motivated by the experiment done by Rychkov *et al.*¹⁴ In this experiment, the setup is a circular actuator configuration with $A/B = 1.0$ in Fig. 6. Hence, the stretch remains fixed even when the voltage is applied. Keeping the stretch fixed prevent creep from taking place, allowing one to measure current leakage through the membrane as if it is a rigid capacitor. The membrane is first pre-stretched and fixed to a rigid frame (Fig. 8(a)). A long time was allowed to elapse for viscoelastic relaxation to take place. Upon equilibration, the membrane is charged up under a fixed voltage and held for a short time, before being switched to an open-circuit condition. Under the open-circuit condition, the current drawn from the voltage source i drops to zero (Fig. 8(b)). Figures 8(c) and 8(d) show the time-histories of stress σ and surface potential Φ across the membrane. σ and Φ are measurable quantities, which may be corroborated with experimental results. We further plot the time-histories of stretch of the dashpot ξ (Fig. 8(e)) and the polarizing charge on the electrodes Q_p (Fig. 8(f)). These

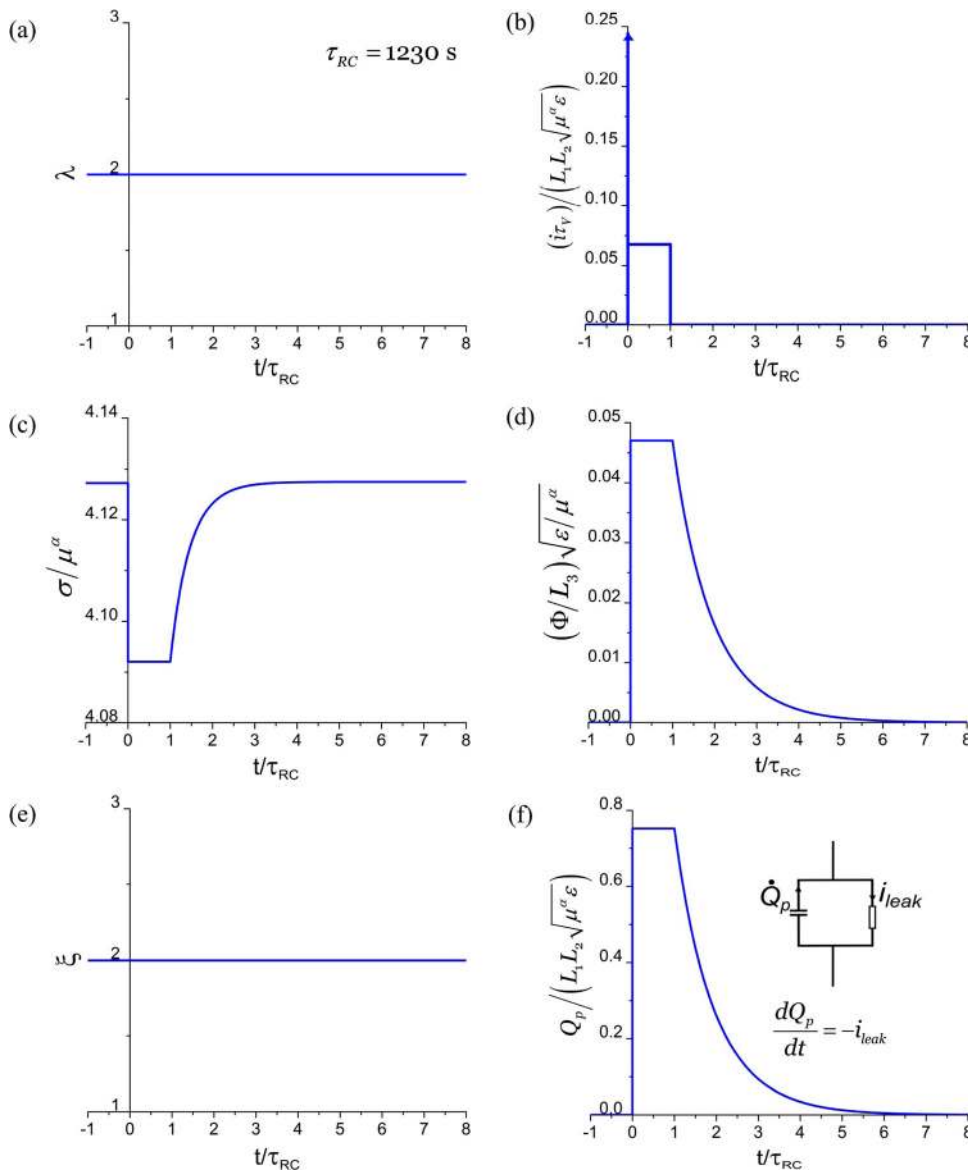

FIG. 8. (Color online) (a) A membrane is under a constant stretch. (b) The current in the conducting wire is suddenly switched on, held at a constant value for a period of charging with a fixed voltage, and then suddenly switched off. (c) stress, (d) voltage, (e) viscous stretch, and (f) charge on the electrodes. Charge leakage occurs through the membrane with a conductive relaxation time τ_{RC} of 1230 s.

parameters provide important information on the respective dissipative processes of viscoelasticity and current leakage, but may not be directly measured in an experiment.

Figure 8(c) shows two features of stress response within a membrane. First, when a pre-stretched membrane is constrained from attaining further deformation, all viscoelastic effects like deformational creep and stress relaxation may be eliminated. This feature was manifested in the instantaneous drop in stress at the point of voltage application, and remained in the relaxed stress state when the voltage was maintained. The absence of viscoelastic effects was confirmed by Fig. 8(e), where the stretch in the dashpot remains constant over the entire test duration. Second, when the setup is switched to the open-circuit condition, charges on the electrodes will leak through the membrane. As more charges leak through the membrane, the stress in the membrane gradually increases. When all charges are leaked through, the stress returns to its original, uncharged level.

Our model may further be used as an aid to determine the optimal operating conditions of a dielectric elastomer

generator. In such a generator, a membrane is first pre-stretched and pre-charged. Subsequent mechanical relaxation in the open-circuit condition provides a voltage boost across the electrodes. Current leakage in the open-circuit condition becomes an important process affecting its performance.⁴¹ If the relaxation process is too slow, leakage current will become very significant, resulting in a very small or even negative voltage boost, which adversely affects the conversion efficiency. This observation was confirmed by experiments in cycles operating at low frequencies.¹¹ Our model may aid the design of cycle frequencies for generators that optimize the conversion efficiency.

Next, we analyze a similar setup as the previous example. In this experiment, all conditions remain the same as the previous one, with the exception of the input voltage. In the previous experiment, the voltage was stepped up instantaneously to a constant level, and maintained constant over a finite time. In this experiment, the voltage was ramped up from zero at a finite rate, up to a specific level, before being held constant (Fig. 9(b)). This was an experiment conducted

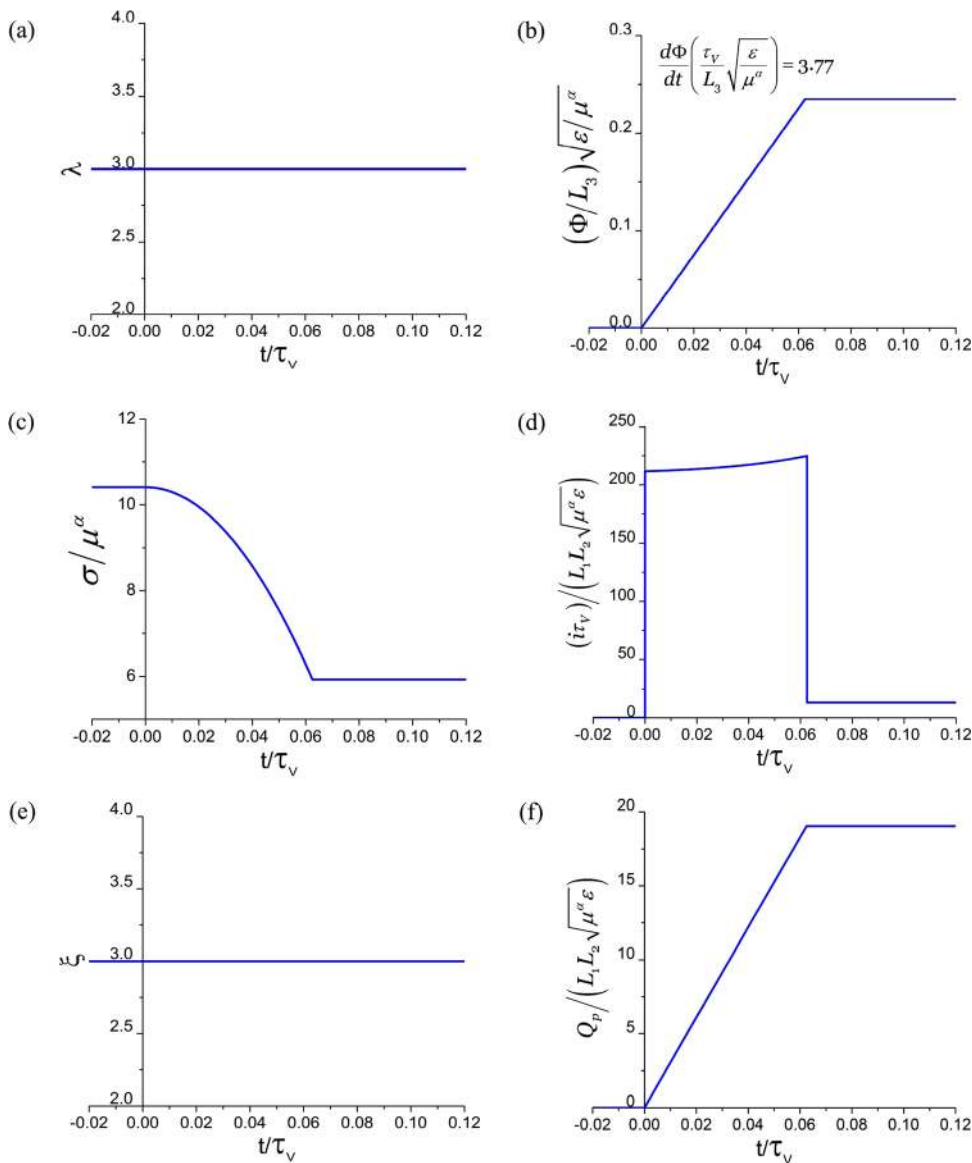

FIG. 9. (Color online) (a) A membrane is under a constant stretch. (b) Voltage is ramped up at a constant rate and is then held at a constant level. The calculated time-histories are shown for (c) stress, (d) current, (e) viscous stretch, and (f) charge on the electrodes.

by Lillo *et al.*²⁶ The purpose of this experiment is to characterize the insulation and dielectric properties of acrylic dielectric elastomer actuators, and also allows one to plot the leakage current versus electric field of a DE. Because our current leakage model is fitted to experimental data,¹⁷ the leakage current versus electric field plot would be identical to that in Fig. 5(b). Similar to the previous example, viscoelastic effects were eliminated (Fig. 9(e)). Both the current i and charge on the electrodes Q_p increase initially as the voltage increases (Figs. 9(d) and 9(f)). The charge on the electrodes is given by

$$Q_p = C\Phi, \quad (28)$$

where C is the capacitance of the membrane, given as $C = \epsilon l_1 l_2 / l_3$. A combination of (24) and (28) gives that

$$i = \Phi \frac{dC}{dt} + C \frac{d\Phi}{dt} + i_{leak}. \quad (29)$$

The total current is contributed by three processes—deformation change (dC/dt), voltage change ($d\Phi/dt$) and leakage current (i_{leak}). In this experiment, the deformation is constrained by the rigid frame, hence $dC/dt = 0$. The total cur-

rent is therefore contributed by voltage change ($d\Phi/dt$) and current leakage. Figures 9(b) and 9(d) clearly show that $i_{leak} > 0$. At higher electric fields, Fig. 9(d) shows an exponential increase in i_{leak} , which is in qualitative agreement with experiments.^{17,26} Because $dC/dt = 0$, Figs. 9(b) and 9(f) show that the charges on the electrodes increase linearly with voltage. Once the voltage is held constant, $d\Phi/dt = 0$, any contribution to total current is due to the leakage current. The leakage current provides a measure of the conductive behavior of the actuator subject to high electric fields. The model allows one to calculate the leakage current and assess the electrical response of the actuator under conditions of high electric field, which is essential to achieve large electrical actuation. Our model may therefore be used to aid the design of efficient actuation cycles.

It is known that pre-stretching a dielectric elastomer may significantly enhance its actuation performance.^{1,10,38,42} When the radius of the electrodes is much smaller than that of the membrane, $A \ll B$, we simplify the setup in the simulation by assuming the active part of the membrane is subject to a constant force. In this example, we study the effect of pre-stress on the current consumption of an actuator. Figure 10(a) illustrates the loading program: a voltage ramps up

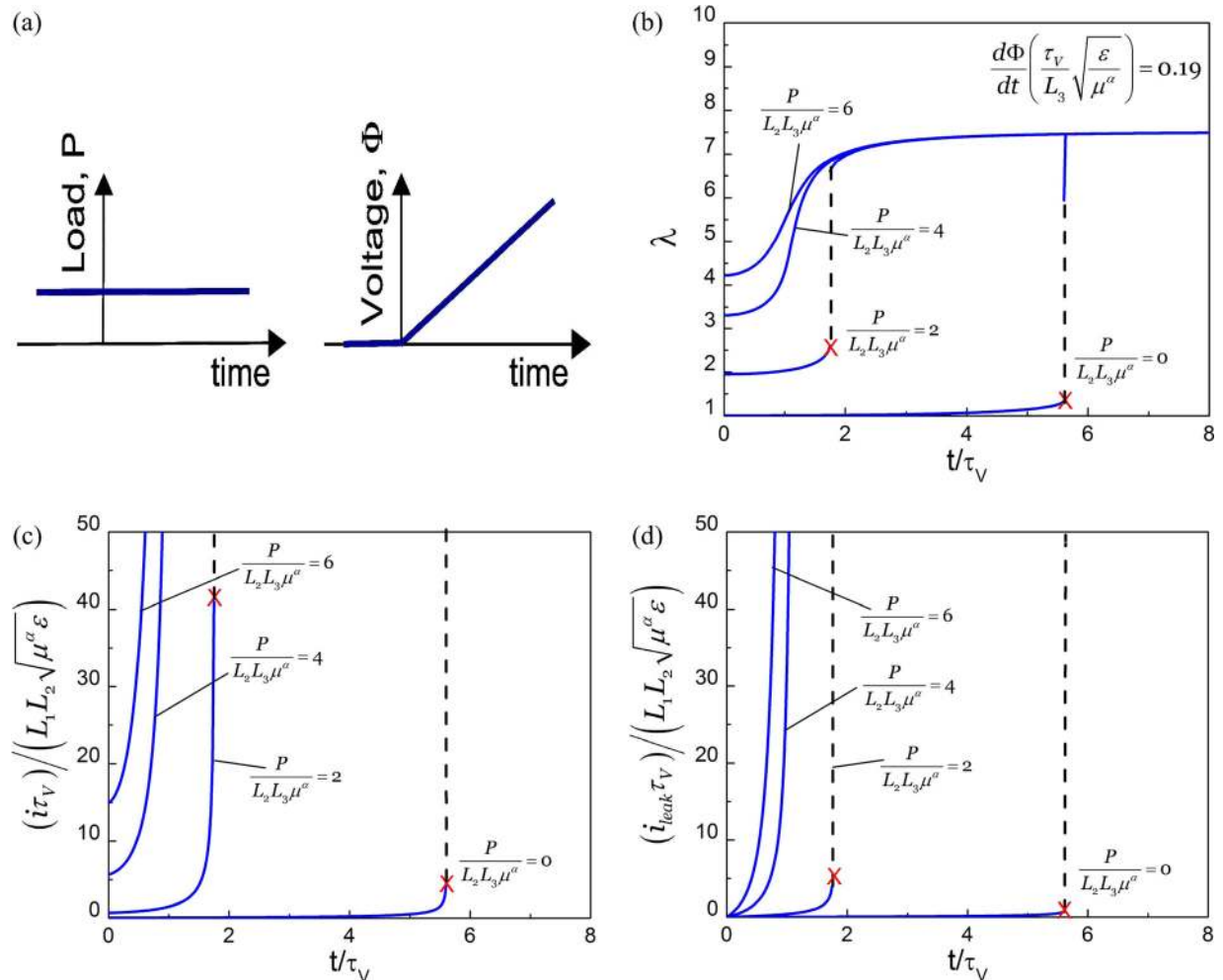

FIG. 10. (Color online) (a) A membrane is subject to a constant force and a ramping voltage. The calculated time-histories are shown for (b) the stretch of the membrane, (c) the current in the conducting wire, and (d) the leakage current through the membrane. At a low level of the applied force, a snap-through instability occurs, marked by a red cross X and a vertical dashed line.

with time under a constant pre-stress. We consider a constant ramping voltage rate for all cases in Fig. 10. As voltage is increased, the stretch of the dielectric elastomer increases (Fig. 10(b)). At zero or low pre-stresses, the stretch increases up to a point denoted by a red cross, X. At this point, electro-mechanical instability (EMI) occurs.^{42–44} As the voltage is increased, the electric field increases with the expanding elastomer. At some point, the same voltage will induce an even higher field; a positive feedback develops between a thinning dielectric elastomer and an increasing electric field—EMI occurs. EMI causes an instantaneous jump from a low stretch level to a high stretch level (Fig. 10(b)), usually leading to electrical breakdown. It is now well known that EMI limits the actuation of a dielectric elastomer to <50% actuation strain,^{45,46} and that a dielectric elastomer may be

stabilized against EMI by pre-stretch or pre-stress, leading to large actuation.^{1,10,35,42} Analytically, EMI occurs when the determinant of the Hessian of the free energy function prescribed in Eq. (14) vanishes.^{20,45} An explicit form of the Hessian can be found in a previous paper.⁴⁵ Fig. 10(b) shows that, at zero or low pre-stress, the membrane undergoes “snap-through” deformation³³ after EMI occurs. When pre-stress is increased, EMI is eliminated, allowing the dielectric elastomer to attain large actuation. Consequently, large actuation also implies very high electric field; leading to an exponential increase in leakage current (Fig. 10(d)) and, hence, huge current consumption (Fig. 10(c)). Although large actuation performance may be achieved at higher pre-stress, the efficiency of such a cycle may be low due to substantial leakage current losses. This observation is consistent

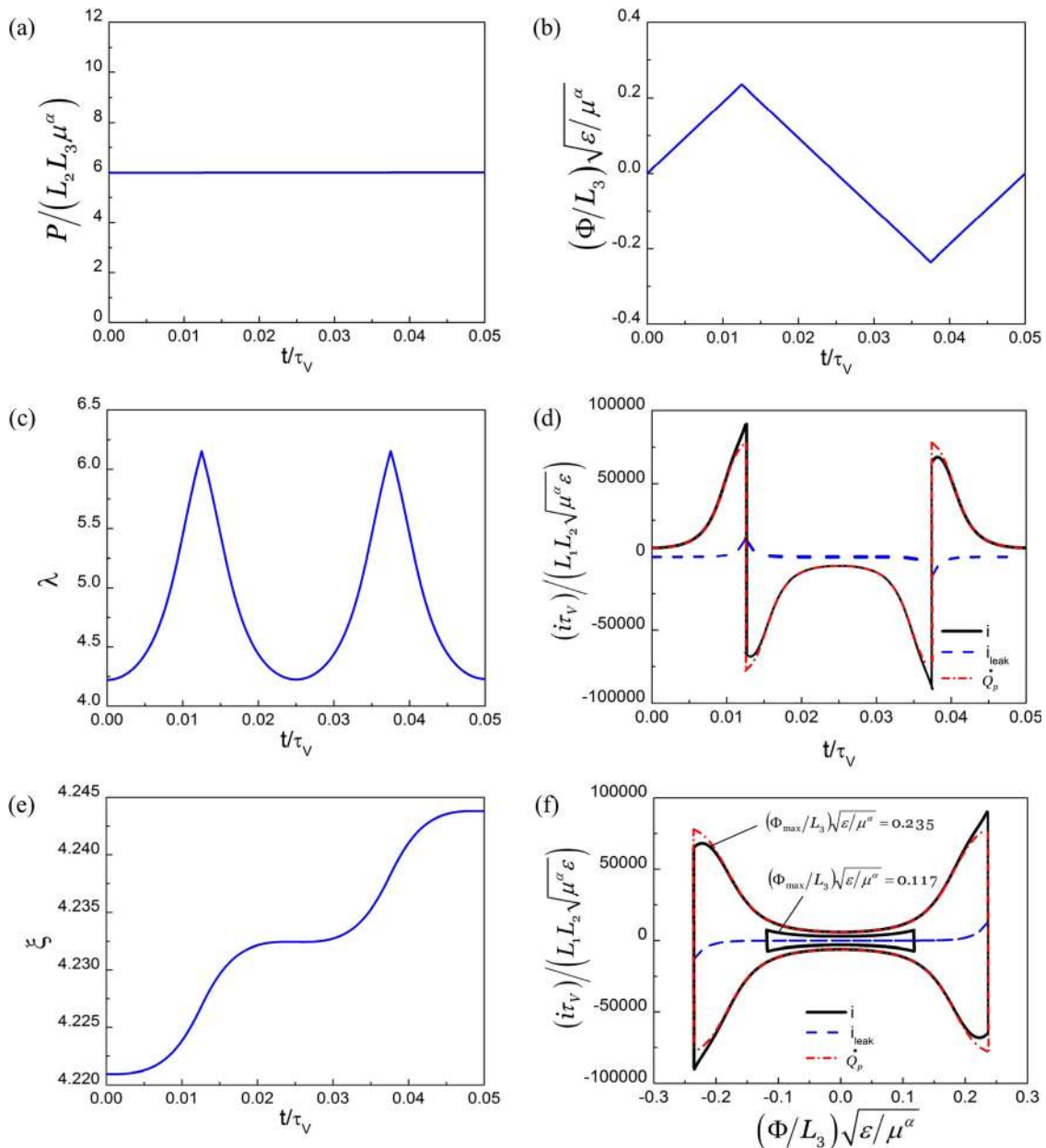

FIG. 11. (Color online) A membrane is subject to (a) a constant force and (b) cyclic voltage. As a result of the fast loading, the viscous loss is small, as indicated by the total and viscous stretches in (c) and (e), respectively. When current leakage becomes significant (d), the current-voltage response in (f) is not symmetric, indicating hysteresis.

with experimental observations, which show current leakage losses reduce the efficiency of actuation cycles to 1% under large actuation stretches.¹¹ To optimize conversion efficiency, one may then need to consider a compromise between large actuation and large current leakage losses.

As a final example, we analyze the response of an actuator subject to a cyclic electric loading (Fig. 11). Such periodic loading will most closely resemble actual operating conditions of an actuator. This set of calculations follows the experiment reported by Bauer and Pajanen.⁴⁰ In that experiment, a circular dot actuator was used (as shown in the schematic in Fig. 6). In our simulations, we shall approximate the boundary conditions for the active dielectric elastomer membrane as being held under a constant pre-stress (Fig. 11(a)), and subject to a triangular cyclic voltage (Fig. 11(b)). Such approximation may not exactly replicate the actual physical conditions in the experiment, but provides a qualitative analysis of the setup, especially when $B \gg A$ in Fig. 6. For exact analysis of this problem, a boundary-value-problem must be solved. The solution to this problem was presented in a separate paper,⁴² and shall not be repeated here.

In this experiment, the voltage was varied on a time-scale much faster than the viscoelastic relaxation time (Fig. 11(b)). As such, the actuation is relatively large (Fig. 11(c)), whereas the viscous effect is negligible due to the fast loading rate (Fig. 11(e)). On the other hand, due to the large actuation and, hence, electric field, current leakage is significant, which makes up about 10% of the total current i at its maximum (Fig. 11(d)). This produces an asymmetric current-voltage response, as observed in the experiment.⁴⁰ For a rigid capacitor, the current-voltage response is rectangular in shape. In Fig. 11(f), a current-voltage response for the dielectric elastomer subject to a smaller voltage amplitude is included for comparison. At that low voltage level, the current-voltage response is almost similar to that of a rigid capacitor. Any deviation from the rectangular shaped current-voltage response is due to the change in capacitance of the DE, the voltage change, and current leakage losses (Eq. (29)). Given that dielectric elastomer actuators are primarily driven by electric fields, current may be an important parameter for actuator control.^{16,40} Current-voltage measurements may then provide useful information about the actuation and leakage losses,⁴⁰ and such measurements may be complemented by our model, as illustrated here.

VII. CONCLUSION

We use nonequilibrium thermodynamics to construct a model of dissipative dielectric elastomers. We focus on two dissipative processes—viscoelasticity and current leakage. This theory is then applied to study the electromechanical response of a membrane subject to time-dependent loadings. Simple descriptions of viscoelasticity and current leakage are used to predict dynamic responses of the membrane. The method may be adapted to analyze more sophisticated modes of deformation and material models. The main results may be summarized as follows. Large actuation strains may be achieved for a pre-stressed actuator, but this is done at the expense of greater losses due to current leakage. One may

need to find a compromise between large actuation strains and good conversion efficiency. When operating as a generator at low frequencies, current leakage may adversely affect the ability of the membrane to store charges in an open-circuit condition, leading to a very poor voltage boost. We also find that current leakage significantly modifies the current-voltage characteristics of dielectric elastomers under cyclic electric fields with high amplitudes. It is hoped that the method may be used as an aid to optimize the conversion efficiency of membrane actuation and generation cycles.

ACKNOWLEDGMENTS

The work at Harvard is supported by the U.S. Army Research Office (ARO) (W911NF-09-1-0476), Defense Advanced Research Projects Agency (DARPA) (W911NF-10-1-0113), and Materials Research Science and Engineering Center (MRSEC). C. C. Foo acknowledges the Post-doctoral Fellowship awarded by the Agency for Science, Technology and Research (A*STAR), Singapore. S. J. A. Koh acknowledges the start-up funding from Ministry of Education (Singapore), administered through the National University of Singapore. S. Bauer acknowledges the support by the Austrian Science Fund (FWF-P22912-N20).

APPENDIX: A MODEL OF DISSIPATIVE DIELECTRIC ELASTOMERS

The model described in Sec. II is written here in a general form for inhomogeneous fields in three dimensions. A review of related models can be found in a previous work.³³ Consider a body of an elastomer in three dimensions. The elastomer in the undeformed state is chosen as the reference state, where each material particle is labeled by its coordinate \mathbf{X} . In the deformed state at time t , the particle \mathbf{X} moves to a place with coordinate $\mathbf{x}(\mathbf{X}, t)$. The deformation gradient is defined by,

$$F_{iK} = \frac{\partial x_i(\mathbf{X}, t)}{\partial X_K}. \quad (\text{A1})$$

Imagine that every material particle \mathbf{X} is attached with a battery of electric potential $\Phi(\mathbf{X})$. Define the nominal electric field by,

$$\tilde{E}_K = -\frac{\partial \Phi(\mathbf{X}, t)}{\partial X_K}. \quad (\text{A2})$$

When the dielectric is in the reference state, denote an element of volume by $dV(\mathbf{X})$. On each element of volume, we prescribe force $\mathbf{B}(\mathbf{X}, t)dV(\mathbf{X})$. In the reference state, denote an element area of the surface of the dielectric by $dA(\mathbf{X})$, and denote the unit vector normal to the element by \mathbf{N} , pointing outside the dielectric. Parts of the surface of the dielectric may be prescribed with displacement, and other parts of the surface of the dielectric may be prescribed with forces. For example, on an element of the surface of the dielectric, $dA(\mathbf{X})$, we may prescribe force $\mathbf{T}(\mathbf{X})dA(\mathbf{X})$, where \mathbf{T} is the nominal density of the surface force (i.e., the traction). Force balance requires that the nominal stress s_{iK} satisfy that,

$$\frac{\partial s_{iK}}{\partial X_K} + B_i = 0, \quad (\text{A3})$$

in the volume, and that,

$$\left(s_{iK}^-(\mathbf{X}, t) - s_{iK}^+(\mathbf{X}, t) \right) N_K(\mathbf{X}, t) = T_i(\mathbf{X}, t), \quad (\text{A4})$$

on an interface.

Similarly, denote $\tilde{q}(\mathbf{X}, t)dV(\mathbf{X})$ to be the charge in an element of volume, and $\tilde{\omega}(\mathbf{X}, t)dA(\mathbf{X})$ the charge on an element of an interface. The nominal electric displacement obeys that,

$$\frac{\partial \tilde{D}_K}{\partial X_K} = \tilde{q}, \quad (\text{A5})$$

in the volume of the body, and,

$$\left(\tilde{D}_K^+(\mathbf{X}, t) - \tilde{D}_K^-(\mathbf{X}, t) \right) N_K(\mathbf{X}, t) = \tilde{\omega}(\mathbf{X}, t), \quad (\text{A6})$$

on the surface of the body.

In the deformed state, let the charges per unit time pumped into a volume element be $r(\mathbf{X}, t)dV(\mathbf{X})$, and into an interface element be $i(\mathbf{X}, t)dA(\mathbf{X})$. The charge also migrates in the dielectric. In the deformed state, let $J_K(\mathbf{X}, t)N_KdA(\mathbf{X})$ be the charge per unit time crossing an element of area. The conservation of charge requires that,

$$\frac{\partial \tilde{q}}{\partial t} + \frac{\partial J_K}{\partial X_K} = r, \quad (\text{A7})$$

in the volume, and,

$$\frac{\partial \tilde{\omega}}{\partial t} + \left(J_K^+(\mathbf{X}, t) - J_K^-(\mathbf{X}, t) \right) N_K(\mathbf{X}, t) = i(\mathbf{X}, t), \quad (\text{A8})$$

on an interface.

Let $WdV(\mathbf{X})$ be the Helmholtz free energy associated with an element of volume. Thermodynamics requires that the increase in the free energy of the dielectric should not exceed the total work done, namely,

$$\int \frac{\delta W}{\delta t} dV \leq \int \Phi r dV + \int \Phi i dA + \int B_i \frac{\partial x_i}{\partial t} dV + \int T_i \frac{\partial x_i}{\partial t} dA. \quad (\text{A9})$$

This inequality holds for every possible dissipative process. A combination of the above equations gives that,

$$\delta \dot{W} \leq s_{iK} \delta \dot{F}_{iK} + \tilde{E}_K \delta \dot{D}_K + \tilde{E}_K J_K. \quad (\text{A10})$$

As a material model, the density of the Helmholtz free energy is taken to be a function of a set of independent variables,

$$W = W(\mathbf{F}, \tilde{\mathbf{D}}, \xi_\alpha, \xi_\beta, \dots), \quad (\text{A11})$$

where $\xi_\alpha, \xi_\beta, \dots$ are internal variables that measure the progress of relaxation processes. Inserting equation (11) into (10), following similar assumptions as in Sec. II, we obtain that,

$$s_{iK} = \frac{\partial W(\mathbf{F}, \tilde{\mathbf{D}}, \xi_\alpha, \xi_\beta, \dots)}{\partial F_{iK}}, \quad (\text{A12})$$

$$\tilde{E}_K = \frac{\partial W(\mathbf{F}, \tilde{\mathbf{D}}, \xi_\alpha, \xi_\beta, \dots)}{\partial \tilde{D}_K}, \quad (\text{A13})$$

$$\sum_\gamma \frac{\partial W(\mathbf{F}, \tilde{\mathbf{D}}, \xi_\alpha, \xi_\beta, \dots)}{\partial \xi_\gamma} \delta \xi_\gamma \leq 0, \quad (\text{A14})$$

$$\tilde{E}_K J_K \geq 0. \quad (\text{A15})$$

- ¹R. Pelrine, R. Kornbluh, Q. Pei, and J. Joseph, *Science* **287**, 836 (2000).
- ²F. Carpi, S. Bauer, and D. De Rossi, *Science* **330**, 1759 (2010).
- ³N. Galler, H. Diltbacher, B. Steinberger, A. Hohenau, M. Dansachmüller, F. Camacho-Gonzales, S. Bauer, J. R. Krenn, A. Leitner, and F. R. Aussegg, *Appl. Phys. B* **85**, 7 (2006).
- ⁴G. Kofod, M. Pajananen, and S. Bauer, *Appl. Phys. A* **85**, 141 (2006).
- ⁵G. Kovacs, L. Düring, S. Michel, and G. Terrasi, *Sens. Actuators A* **155**, 299 (2009).
- ⁶F. Carpi, G. Frediani, M. Nanni, and D. D. Rossi, *IEEE/ASME Trans. Mechatron.* **16**, 16 (2011).
- ⁷C. Keplinger, M. Kaltenbrunner, N. Arnold, and S. Bauer, *Proc. Natl. Acad. Sci. U.S.A.* **107**, 4505 (2010).
- ⁸F. Carpi, D. D. Rossi, R. Kornbluh, R. Pelrine, and P. Sommer-Larsen, *Dielectric Elastomers as Electromechanical Transducers*, 1st ed. (Elsevier, Amsterdam, 2008).
- ⁹T. McKay, B. O'Brien, E. Calius, and I. Anderson, *Smart Mater. Struct.* **19**, 055025 (2010).
- ¹⁰J. S. Plante and S. Dubowsky, *Int. J. Solids Struct.* **43**, 7727 (2006).
- ¹¹J. S. Plante and S. Dubowsky, *Sens. Actuators A* **137**, 96 (2007).
- ¹²M. Molberg, Y. Leterrier, C. J. G. Plummer, C. Walder, C. Löwe, D. M. Opris, F. A. Nüesch, S. Bauer, and J. -A. E.E. Månson, *J. Appl. Phys.* **106**, 054112 (2009).
- ¹³A. York, J. Dunn, and S. Seelecke, *Smart Mater. Struct.* **19**, 094014 (2010).
- ¹⁴D. Rychkov, M. Dansachmüller, H. Ragusch, A. Becker, and G. Kofod, in 2010 10th IEEE International Conference on Solid Dielectrics (Potsdam, Germany, 2010), pp. 1.
- ¹⁵P. Lochmatter, G. Kovacs, and M. Wissler, *Smart Mater. Struct.* **16**, 477 (2007).
- ¹⁶C. Keplinger, M. Kaltenbrunner, N. Arnold, and S. Bauer, *Appl. Phys. Lett.* **92**, 192903 (2008).
- ¹⁷T. A. Gisby, S. Q. Xie, E. P. Calius, and I. A. Anderson, *Proc. SPIE* **7642**, 764213 (2010).
- ¹⁸G. Kofod and P. Sommer-Larsen, in *Dielectric Elastomers as Electromechanical Transducers*, edited by F. Carpi, D. D. Rossi, R. Kornbluh, R. E. Pelrine, and P. Sommer-Larsen (Elsevier, Amsterdam, 2008), pp. 159.
- ¹⁹M. Wissler and E. Mazza, in *Dielectric Elastomers as Electromechanical Transducers*, edited by F. Carpi, D. D. Rossi, R. Kornbluh, R. E. Pelrine, and P. Sommer-Larsen (Elsevier, Amsterdam, 2008), pp. 169.
- ²⁰X. Zhao, S. J. A. Koh, and Z. Suo, *Int. J. Appl. Mech.* **3**, 1 (2011).
- ²¹A. S. A. Reffae, D. E. El Nashar, S. L. Abd-El-Messieh, and K. N. Abd-El Nour, *Mater. Des.* **30**, 3760 (2009).
- ²²M. Seki and K. Sato, *Macromol. Chem. Phys.* **196**, 1813 (1995).
- ²³D. A. Seanor, *Adv. Polym. Sci.* **4**, 317 (1965).
- ²⁴G. G. Raju, in *Dielectrics in Electric Fields* (Marcel Dekker, New York, 2003), pp. 329–382.
- ²⁵A. R. Blythe and D. Bloor, in *Electrical Properties of Polymers* (Cambridge University Press, Cambridge, U.K., 2005), pp. 111–153.
- ²⁶L. Di Lillo, A. Schmidt, A. Bergamini, P. Ermanni, and E. Mazza, *Proc. SPIE* **7976**, 79763B (2011).
- ²⁷C.-C. Chiang, I.-H. Ko, M.-C. Chen, Z.-C. Wu, Y.-C. Lu, S.-M. Jang, and M.-S. Liang, *J. Electrochem. Soc.* **151**, 93 (2004).
- ²⁸J.-P. Crine, *IEEE T. Dielect. El. In.* **4**, 487–495 (1997).
- ²⁹C. Dang, J.-L. Parpal, and J.-P. Crine, *IEEE T. Dielect. El. In.* **3**, 237–247 (1996).
- ³⁰J.-L. Parpal, J.-P. Crine, and C. Dang, *IEEE T. Dielect. El. In.* **4**, 197–209 (1997).
- ³¹J.-P. Crine, *IEEE Trans. Dielectr. Electr. Insul.* **9**, 697 (2002).

- ³²N. Parkman, in *Physics of Plastics*, edited by P. D. Ritchie (Iliffe, London, 1965), pp. 285–322.
- ³³Z. Suo, *Acta Mech. Solida Sinica* **23**, 549 (2010).
- ³⁴D. I. Bower, in *An Introduction to Polymer Physics* (Cambridge University Press, Cambridge, U.K., 2002), pp. 248–283.
- ³⁵G. Kofod, P. Sommer-Larsen, R. Kornbluh, and R. Pelrine, *J. Intell. Mater. Syst. Struct.* **14**, 787 (2003).
- ³⁶X. Zhao, W. Hong, and Z. Suo, *Phys. Rev. B* **76**, 134113 (2007).
- ³⁷J. S. Bergstrom and M. C. Boyce, *J. Mech. Phys. Solids* **46**, 931 (1998).
- ³⁸W. Hong, *J. Mech. Phys. Solids* **59**, 637 (2011).
- ³⁹A. N. Gent, *Rubber Chem. Tech.* **69**, 59 (1996).
- ⁴⁰S. Bauer and M. Paajanen, *Proc. SPIE* **6168**, 61682K (2006).
- ⁴¹S. J. A. Koh, X. Zhao, and Z. Suo, *Appl. Phys. Lett.* **94**, 262902 (2009).
- ⁴²S. J. A. Koh, T. Li, J. Zhou, X. Zhao, W. Hong, J. Zhu, and Z. Suo, *J. Polym. Sci. Part B: Polym. Phys.* **49**, 504 (2011).
- ⁴³Z. Suo and J. Zhu, *Appl. Phys. Lett.* **95**, 232909 (2009).
- ⁴⁴X. Zhao and Z. Suo, *Phys. Rev. Lett.* **104**, 178302 (2010).
- ⁴⁵X. Zhao and Z. Suo, *Appl. Phys. Lett.* **91**, 061921 (2007).
- ⁴⁶R. Pelrine, R. Kornbluh, Q. Pei, and J. Joseph, *Science* **287**, 836 (2000).