

Model Reference PID Control of an Electro-hydraulic Drive

Ayman A. Aly

Mechatronics Sec., Mechanical Eng. Dept., Faculty of Engineering, Assiut University, Assiut, 7156, Egypt,
Currently: Mechatronics Sec., Mechanical Eng. Dept., College of Engineering, Taif University, Taif, 888, Saudi Arabia.
Email: draymanelnaggar@yahoo.com

Abstract—Hydraulic cranes are inherently nonlinear and contain components exhibiting strong friction, saturation, variable inertia mechanical loads, etc. The characteristics of these non-linear components are usually not known exactly as structure or parameters. For these reasons, tuning of the traditional PID controller parameters to control this system for the required performance faces a strong challenge.

In this paper a new approach to design an adaptive PID control has the ability to solve the control problem of highly nonlinear systems such as the hydraulic crane was proposed. The core of the design method depends on comparing the performance of the Model Reference (MR) response with the nonlinear model response and feeding an adaptation signal to the PID control system to eliminate the error in between. It is found that the proposed MR-PID control policy provided the most consistent performance in terms of rise time and settling time regardless of the nonlinearities.

Index Terms— Hydraulic Crane, Nonlinear PID, Model Reference, Adaptive Control

I Introduction

Electrohydraulic drives are widely used in industrial applications, such as in rolling and paper mills, as “actuators” in aircraft, and in many different automation and mechanization systems. The main reason for their broad industrial applications is the great power capacity that they can exert (as compared to their DC or AC counterparts), while preserving good dynamic response and system resolution, [1].

Hydraulic systems consist of various elements: pumps, actuators, control valves, accumulators, restrictors, pipelines and the like, which include many types of nonlinearities, such as pressure-flow characteristics in control valves, dry friction acting on actuators and moving parts of valves, collision of valves against valve seats, [2]. It is a marked feature of nonlinear systems that global behaviors are sometimes quite different from local behaviors. In such cases, results of linear analysis are unavailable to estimate global nature of the system.

Systems containing fluid power components offer interesting and challenging applications of modern and classical control techniques. The use of microcomputers and many feedback devices for hydraulic drives allows for implementation of different control algorithms that result in better steady-state and dynamic performances in fluid power control systems. There are a number of research results on the applications of adaptive control [2], robust control [3], and variable structure control [4] in electrohydraulic control systems.

In the Sliding Mode Control (SMC) method, the system trajectory is forced to reach the sliding surface and to slide along it, or to remain in its vicinity, [4]. Since in many situations the SMC is found robust to a great extent to plant parameter variations or uncertainties in the model of the system to be controlled, it has found broad applications. However, the chattering is a signify problem in the SMC implementations and solutions that either reduce or eliminate it had been investigated in [5, 6].

In a parallel way, even though fuzzy logic controllers often produce results superior to those of traditional controllers [7], the control engineer has found difficulties in accessing the fuzzy logic controllers because of the following limitations: The design of the fuzzy logic controller is not straight forward due to heuristics involved with control rules and membership functions. There is no standard systematic method for tuning the fuzzy logic controller parameters.

Gholamreza and Donath [8] recognized that a hydraulically actuated system contains a host of nonlinear elements, thereby making a linear controller ineffective. Furthermore, the authors illustrated that linearization of the dynamic equations over a small operating range and the design of an appropriate controller for each condition had limitations in the face of time variable parameters changes.

Most of the recent work performed on hydraulically actuated linkages has focused on developing some type of adaptive controller, [2, 3]. These controllers are meant to compensate in real-time for nonlinear elements such as friction and smooth time-variant load changes. These methods rely on continuous noise-free feedback and are generally computationally intense making them non-ideal for application to low cost mobile equipment.

The aim of this paper is to design a nonlinear PID control has the ability to solve the control problem of highly nonlinear systems such as the hydraulic crane, which is shown in Fig.1. This will be done by first deriving a nonlinear mathematical model of the system and then approximating the transfer functions in the model by low order linear transfer functions. Using the

low order linear transfer functions, design optimal gains of the PID regulator is determined. The final step is implementing the designed PID controller in the nonlinear model and then comparing the performance of MR response with the nonlinear model and feeding a correction signal to tune the PID control system parameters to eliminate the error in between.

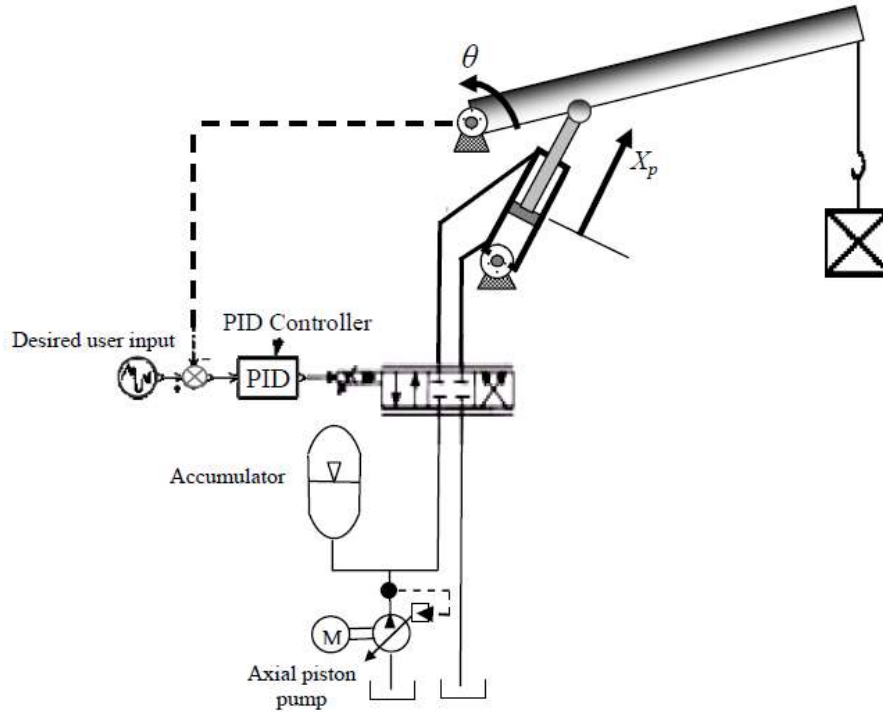

Fig. 1: Hydraulic Crane System

II System Construction

The servo system is composed of a hydraulic power supply, an electrohydraulic servo valve, a cylinder, mechanical linkages, and control. The piston position of the cylinder is controlled as follows: Once the voltage input corresponding to the desired position is transmitted to the servo controller, the controller signal current is generated. Then, the valve spool position is changed according to the input current applied to the torque motor of the servo valve. Depending on the spool position and the load conditions of the piston, the rate as well as the direction of the oils supplied to each cylinder chamber is determined. The motion of the piston then is controlled by these oils.

If it is necessary to represent servo valve dynamics through a wider frequency range, a second-order transfer function must be used. The relation between the servo valve spool position x_v and the input current i_v can be written as, [2]

$$\frac{d^2 x_v}{dt^2} + 2\zeta_v \omega_v \frac{dx_v}{dt} + \omega_v^2 x_v = \omega_v^2 k_v i_v \quad (1)$$

where k_v represents the gain of the servo valve, ω_v is the natural frequency of the servo valve, and ζ_v is the damping ratio of the servo valve.

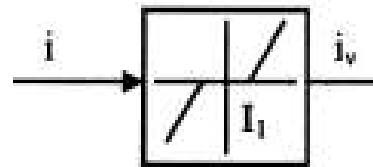

Fig. 2: Characteristic of the dead zone

The valve spool occludes the orifice with some overlap so that for a range of spool positions there is no fluid flow. This overlap prevents leakage losses that increase with wear and tear. Thus, the dead zone should be placed between the valve dynamics and actuator/load dynamics. For the sake of simplicity, this dead zone is equivalently moved to the position between the output of the controller and the input current of the valve. So, the dead zone nonlinearity may be characterized as shown in Fig. 2 and approximately described as:

$$i_v = \begin{cases} i - I_1 & \text{if } i > I_1 \\ 0 & \text{if } |i| \leq I_1 \\ i + I_1 & \text{if } i < -I_1 \end{cases} \quad (2)$$

where i_v is the current from the controller and I_1 the width of the dead zone.

The equations of the servo valve flow to and from the actuator (assuming symmetric valve port, zero lap design and zero return pressure) are as follows,

For positive x_v ,

$$q_f = C_d W x_v \operatorname{sgn}(P_s - P_f) \sqrt{\frac{2}{\rho} |P_s - P_f|}$$

$$q_n = C_d W x_v \operatorname{sgn}(P_n) \sqrt{\frac{2}{\rho} |P_n|} \quad (3)$$

For negative x_v ,

$$q_f = C_d W x_v \operatorname{sgn}(P_f) \sqrt{\frac{2}{\rho} |P_f|}$$

$$q_n = C_d W x_v \operatorname{sgn}(P_s - P_n) \sqrt{\frac{2}{\rho} |P_s - P_n|} \quad (4)$$

where x_v is the spool displacement, P_s is the supply pressure, ρ is the mass density of the oil, C_d is the discharge coefficient of the orifice, W is the width of the orifice, suffix n denotes the annular side and suffix f denotes the full side.

The linearized flow equation of the actuator is given by [8]:

$$q_{le} = K_l \frac{A_e}{A_f} \left[\frac{1 + \left(\frac{A_n}{A_f}\right)^2}{1 + \left(\frac{A_n}{A_f}\right)^3} \right] P_{le} + A_e \dot{X}_p + \frac{2A_e}{A_f} \frac{\dot{P}_{le}}{4B} \left[\frac{V_f + \left(\frac{A_n}{A_f}\right) V_n}{1 + \left(\frac{A_n}{A_f}\right)^3} \right] \quad (5)$$

where

$$P_{le} = \frac{p_f A_f - p_n A_n}{A_e}, \quad q_{le} = \frac{q_f + q_n}{2}, \quad A_e = \frac{A_f + A_n}{2}$$

P_{le} is the effective load pressure, q_{le} is the effective load flow rate, A_e is the effective piston area, B is the oil bulk modulus, k_l is the leakage coefficient of the piston, X_p is the piston displacement, V_n is the oil volume under compression in the annular side of the cylinder, V_f is the oil volume under compression in the full side of the cylinder, A_n is the annular area of the cylinder, A_f is the full area of the cylinder.

The motion equation of the crane is given by

$$P_{le} A_e = M_e \ddot{X}_p + B_e \dot{X}_p + F_d \quad (6)$$

where M_e represents the equivalent mass of both the variable inertia load and the piston, B_e is the equivalent viscous damping coefficient, and F_d represents the disturbing forces like friction forces.

The various friction characteristics depend on lubrication, relative velocities of bodies at the contact point, pressures and others [1, 2]. A typical friction characteristic is presented in Fig.3. The mathematical description of friction process in hydraulic cylinders involves serious difficulties caused by:

- Presence of a wide range of different sealing elements in dynamic connections (O-rings, V-type seals, packing seal).
- Applications of various sealing materials rubbers or composite materials.
- Influence of temperature on friction resistance due to the fact that sealing materials have higher thermal expansion coefficient than metal elements.
- Deposition of solid contaminations on the piston rod.

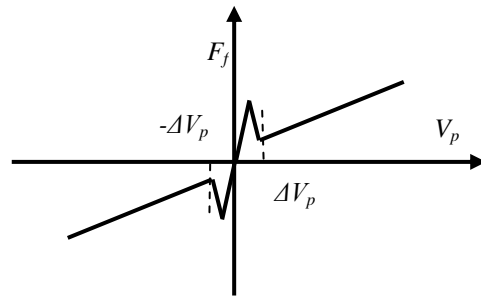

Fig.3: Characteristic of the friction

Thus exact simulation of the nonlinear behavior of friction in the vicinity of a zero velocity is difficult. The friction force is approximately simulated by the stick-slip friction law. The value of the stick-slip friction for positive values of X_p is given simply by

$$F_f = \begin{cases} F_{st} & \text{for } 0 \leq V_p < \Delta V_p \\ F_{sl} & \text{for } V_p \geq \Delta V_p \end{cases} \quad (7)$$

where F_{sl} is the slip friction, F_{st} is the stick friction, and V_p is the piston speed.

The dynamics of hoses and pipes connecting the servovalve and the actuator are simulated by a time delay function. The transport lag function is given by

$$H(s) = e^{-sT_d} \quad (8)$$

Transport delays are approximated by a first-order lag

$$e^{-sT_d} \cong \frac{1}{\left(\frac{T_d}{2}\right)s + 1} \tag{9}$$

where T_d is the delay time. The approximation introduces an extra pole to the system transfer function,

but, unlike Pade's method, it does not introduce an extra zero, [2].

The actuator is equipped with one hydraulic accumulator in the supply port to cope with the dynamic flow demands. A LVDT position transducer measures piston displacement with gain of 0.1 m/V. The block diagram of the hydraulic crane system is shown in Fig. 4. The system geometric transformation and its physical parameters are illustrated in Appendixes-A and B.

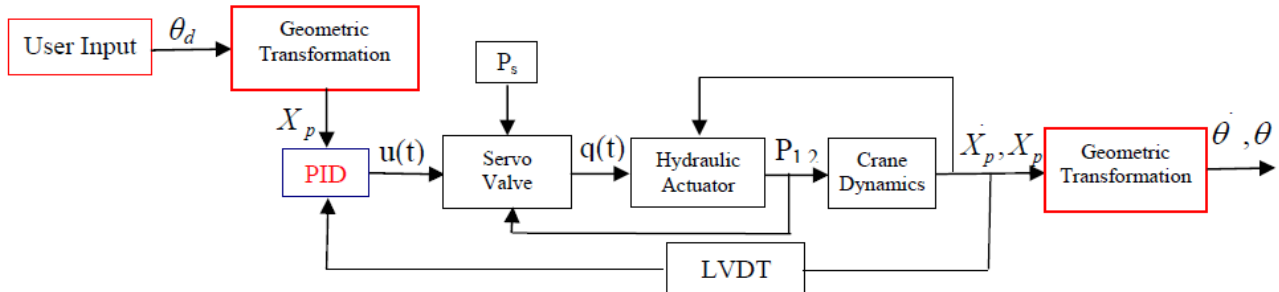

Fig. 4: Block diagram of the hydraulic crane system

III Controller Design

PID-controller is the most common in many industrial applications and it has been stated in many papers that a PID-controller has been used in hydraulic position servo systems [2, 3, 9, 10 and 11]. It is very natural solution to the controller of a type 0 system (velocity control, temperature control, pressure control). A position servo system is, however, a type 1 system, and this means that there is already an integrator in the forward loop (actuator, cylinder, or motor). On the

basis of the understanding obtained from the analysis of plant dynamics and its nonlinearities, one can a set of control requirements. The most serious nonlinearities are the nonlinearities of valves, load, and friction forces. According to linear theory of hydraulic servo systems the nonlinearities, which are in the forward loop before the integrator as shown in Figure 5, cause the position error in position servo systems, and it is responsible for performance limitations. Unquestionably, the plant as a whole poses a very difficult dynamics to control.

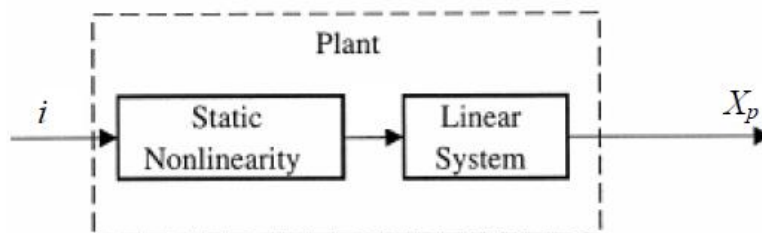

Fig. 5: Model of the hydraulic drive system

As detailed model of the crane would be difficult to derive so it is too complex to be used in regulator design. The common solution is often at first approximate the real complex model to linearized one and finally adjust nearly the PID controller parameters according to standard design method such as Ziegler-Nichols, [12] method which is considered in the most popular one during the last 50 years. The linear PID-control algorithm in Laplace form is presented as follow,

$$U(s) = \left[K_p + \frac{K_I}{s} + K_D s \right] E(s) \tag{10}$$

where $U(s)$, $E(s)$ are the controller output and system response error, K_p , K_I , and K_D are the proportional, integral and derivative PID gains respectively. According to the studies of many researchers in the field of fluid power control systems, [3, 4, 5 and 7] the following conclusions can be made:

Linear PID-controllers are not suitable controllers for hydraulic position servo because of overshoots and limit cycles. Since PID controller parameters are usually designed using either one or two measurement points of the system frequency response as Ziegler-Nichols method, their control performance may not satisfy the desired time-response requirements.

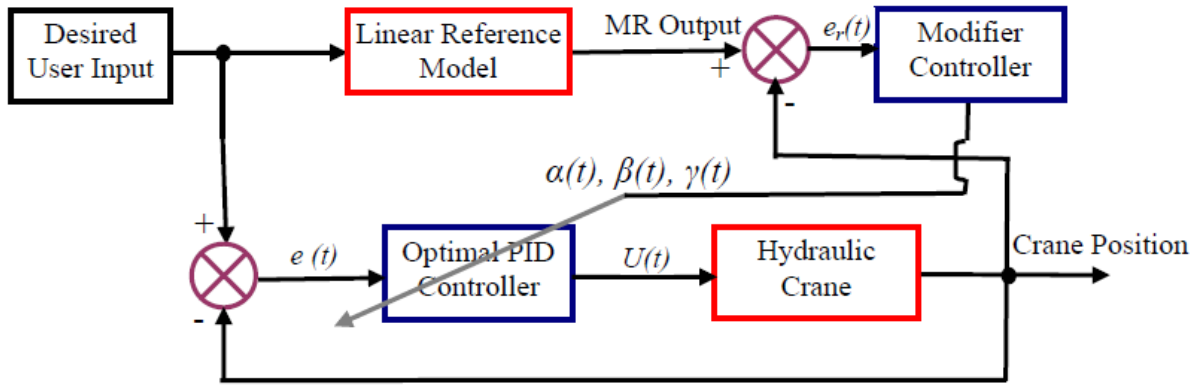

Fig. 6: Block Diagram of Crane hydraulic Control System

When a system has different operating points with widely differing dynamic properties and high position accuracy is required, it is not always possible to control it with a fixed parameter controller, a nonlinear design of PID-controller might be a solution. So it seems a good idea to use a model reference control system based on PID control policy can guide the system regardless the exit nonlinearities. The proposed scheme is shown in Fig. 6.

The steps of the proposed control strategy is as follows,

The first step is approximating the nonlinear hydraulic crane model to linearized one by ignore all nonlinearities and design an optimal PID controller for it. In order to have a good closedloop time response, the following performance function needs to be considered during the design of the PID controller parameters:

$$J(K_p, K_I, K_D) = ITASE \quad (11)$$

where *ITASE* is the integral time absolute square error of the system output. Thus, the optimal PID controller design problem may be stated as

$$J_{K_p, K_I, K_D}(K_p, K_I, K_D) \quad (12)$$

The second step is implementing the optimal designed PID controller in the nonlinear model. Of course the system response will be worth than the response of the linearized one.

The third step is defining the reference model, in the time domain; specifications for a control system design involve certain requirements associated with the time response of the system. The requirements are often expressed in terms of the standard quantities on the rise time, settling time, overshoot, and steady-state error of a step response. The time response of a standard second-order system is widely used to represent the above time-domain requirements as a model reference to the real nonlinear time variant system. Thus, the second-order system is chosen for the tracking mode, whose transfer function is

$$G_m(s) = \frac{\omega_m^2}{s^2 + 2\zeta_m \omega_m s + \omega_m^2} \quad (13)$$

where the parameters ω_m is the model natural frequency and ζ_m the model damping ratio, which are chosen according to the desired time-domain response requirements of the closed-loop system.

The fourth step is modifying the nonlinear model response by comparing it with the MR response and fed a modifier signal to eliminate the error in between of them by correction the PID controller action.

Using modifying law similar to Equation (10), one obtains the rules base for the modifier controller. The variations in the PID gains will be as follows:

$$\Delta K_p = \alpha(t) \cdot K_p,$$

$$\Delta K_I = \beta(t) \cdot K_I,$$

$$\Delta K_D = \gamma(t) \cdot K_D,$$

$$\alpha(t) = K_{pm} \cdot e_r(t),$$

$$\beta(t) = K_{Im} \int e_r(t) dt \quad \text{and}$$

$$\gamma(t) = K_{Dm} \frac{de_r(t)}{dt} \quad (14)$$

where $e_r(t)$ is the relative error between the MR and the system response, $ce_r(t)$ is change in the relative error, ΔK_p , ΔK_D , and ΔK_I are the PID gains variation, K_p , K_D , and K_I are the calculated gains of the PID controller based on Equation (12), $\alpha(t)$, $\beta(t)$ and $\gamma(t)$ are the modifier outputs and K_{pm} , K_{Im} and K_{Dm} are scaling factors.

IV Simulation

The continuous PID was automatically converted to a discrete form with sampling period was chosen to be 0.001 sec. by considering the fast plant dynamics. The cost function was given by $J(K_p, K_I, K_D)$. The reference

input was a step signal, which changed from 0 to 10 degree. Using the MATLAB optimization toolbox, the optimal PID parameters $K_P=34.286$, $K_I= 0.686$ and $K_D=0.171$ were found (to three decimal places, thereafter).

Figure 7.a shows the closed-loop responses due to step input of linearized and nonlinear model with the

optimal PID controller which, was designed based on the linearized model. It is clear that the difference in the two responses due to the nonlinearities of the system which appears as increasing in the overshoots, rise time and settling time however, the steady state error is zero in the two cases. The corresponding controller signals for each case are shown in Fig.7.b.

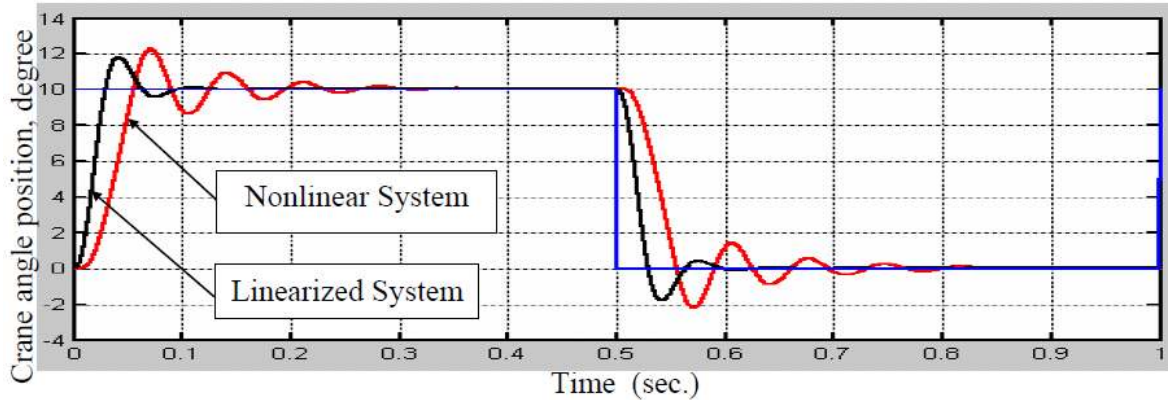

Fig. 7-a: Step response of closed loop systems with different settings

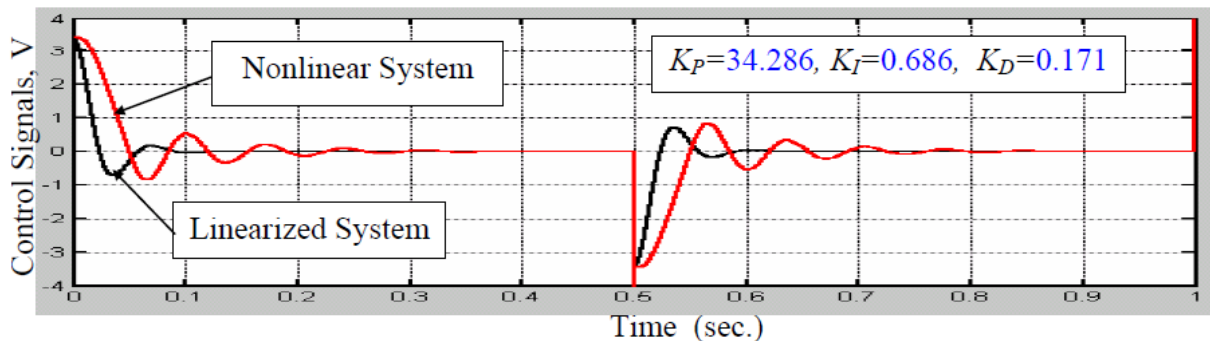

Fig. 7-b: The control signals based on optimal PID Controller

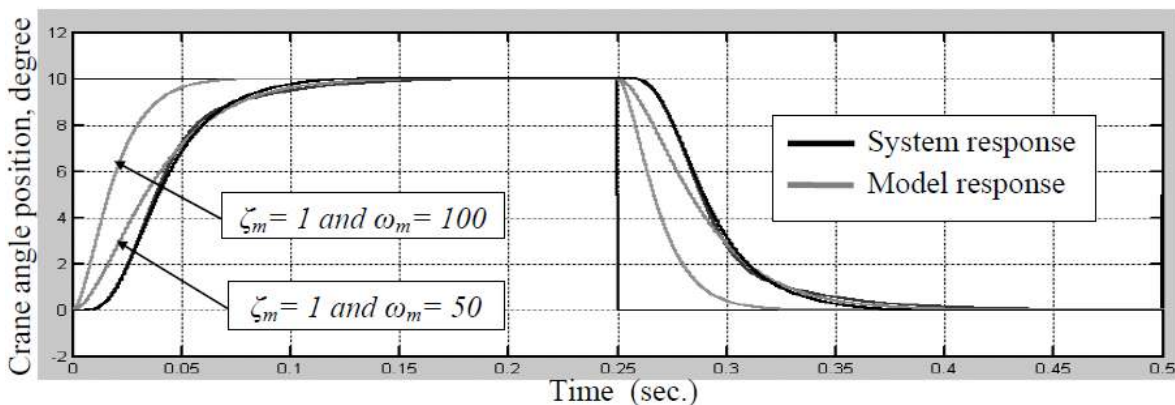

Fig. 8-a: Step response of the system based on the proposed controller

Since in many industrial applications, it is necessary to assure that the response has minimum/no overshoot, this is achieved in Fig.8.a which, illustrates the model reference responses and the nonlinear system responses based on the proposed control policy with model damping ratio ($\zeta_m = 1$) and two suggested model natural

frequencies ($\omega_m = 50$ and 100 rad/sec). It is easy to decide the value of ζ_m to be critically damped however the value of ω_m need extra effort to be chosen within the physical limitation of the cylinder maximum velocity. It is noticed that the responses are improved compared with the responses of Fig.7.a where, there is smaller

settling and rise times with no steady state error or overshoot. In the nonlinear PID controller design, a higher level is the model reference controller, which, at any instant, evaluates control performance and adapts the output of the controller according to the relative error in the performance of the reference model and the nonlinear system responses.

The parameters of the modifier controller were $K_{Pm}=1.45$, $K_{Im}=0.720$ and $K_{Dm}=0.140$. The crossholdings controller outputs of the proposed strategy for the tested model are illustrated in Fig.8.b. It is interesting to notice that the amplitude of controller's signals became smaller with implementing the proposed

strategy compared with Fig. 7.b, which is signifying index in the hydraulic system design and in its power energy saving.

Figure 8.c represents the modification signals in the PID control of the nonlinear system with the two tested models. It is a remarkable notice that the modification mechanism work only with the transient change in the system response.

Another good application with sinusoidal input signal as a continuous motion test for the proposed controller policy with the nonlinear system is shown in Fig.9. The system response follows the model reference with delay of 17 msec.

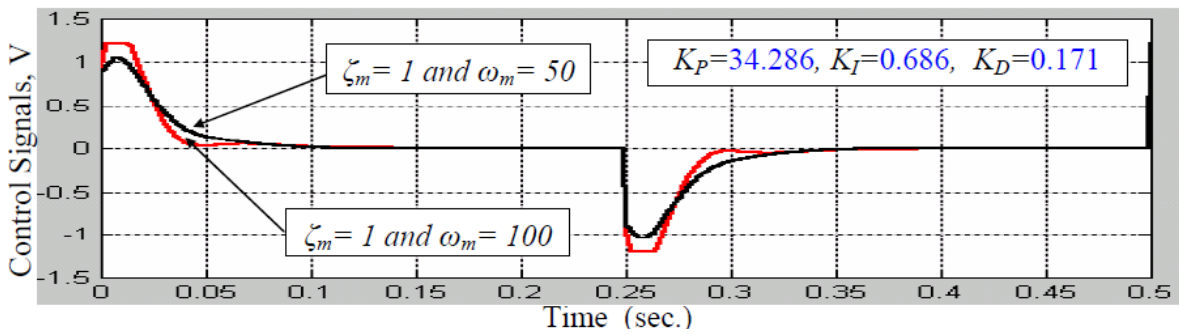

Fig. 8-b: Controller signals

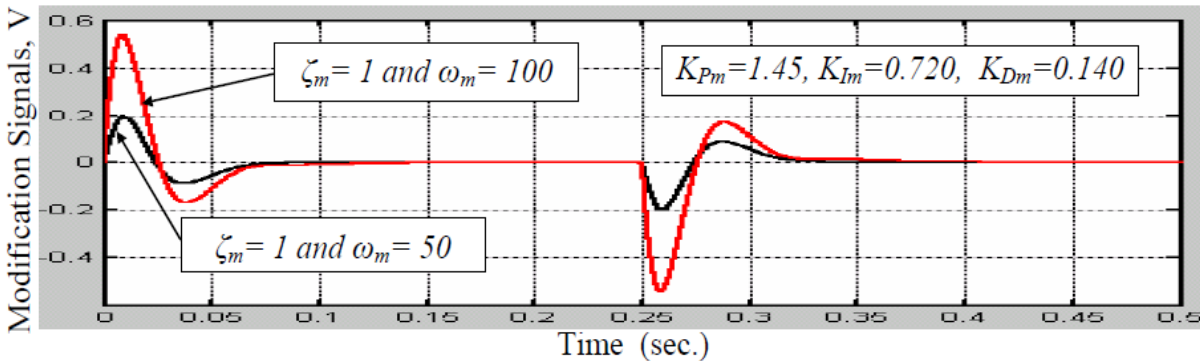

Fig. 8-c: Modifier controller signals

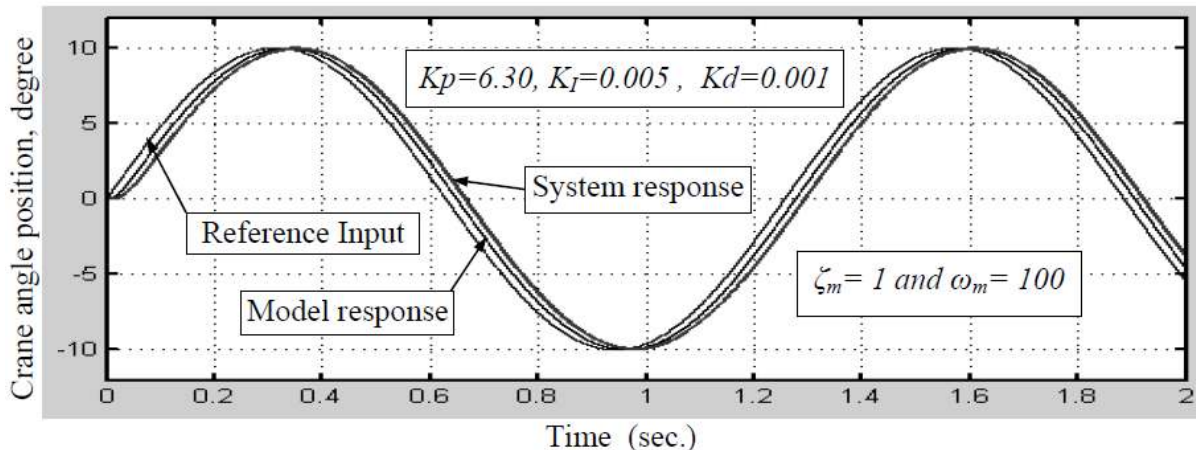

Fig. 9: Sin wave response of the system based on the proposed controller

V Conclusions

Nonlinear dynamic phenomena in hydraulic systems are unique and diverse. It is difficult to estimate their global nature from local nature by linear analysis. Thus, the hydraulic systems are often very conservatively tuned. In addition the fact that the cost of getting the tuning wrong can be highly destructive and costly. To effectively assess the performance of the proposed tuning method, the control system performance is evaluated via simulations.

In this paper the position control problem of a hydraulic crane was addressed. The highly nonlinear behavior of the system limits the performance of classical linear controllers used for this purpose. It has been demonstrated that the MR-PID control can be successfully implemented in the control system of a hydraulic crane. Since there are nonlinearities in the hydraulic position control system, it is difficult to achieve high-precision tracking performance using only linear PID controllers. The results obtained show that the proposed controller policy exhibits much better response, much better tracking characteristics, and retains excellent following motion property comparable to, or better, than that obtained by the conventional optimally tuned PID controller.

In addition to faster and more accurate responses, the proposed controller design steps are simple, thus, the application of the algorithm can be made wider than that of the conventional PID controllers.

References

- [1] H.E. Merrit, "Hydraulic control systems", John Wiley & Sons, 1976.
- [2] J. Watton. "Fluid power systems: Modeling, simulation, analog and microcomputer control", Prentice-Hall International, London, UK, 1989
- [3] J.W. Dobchuk, "Control of a Hydraulically Actuated Mechanism Using a Proportional Valve and a Linearizing Feedforward Controller", PhD, Department of Mechanical Engineering, University of Saskatchewan, Saskatoon, Canada, Aug. 2004.
- [4] A. Bonchis!, P. I. Corke, D. C. Rye and Q. P. Ha, "Variable Structure Methods In Hydraulic Servo Systems Control", *Automatica* (37), pp 589-595, 2001.
- [5] Daohang Sha a, Vladimir B. Bajic b and Huayong Yang, "New Model and Sliding Mode Control of hydraulic Elevator Velocity Tracking System", *Simulation Practice and Theory Journal* (9), pp 365-385, 2002.
- [6] G. Bartolini, A. Ferrara and E. Usai, "Chattering Avoidance By Second-Order Sliding Mode Control", *IEEE Trans. Autom. Control* 43 (2), pp 241-246, 1998.
- [7] Ayman A. Aly and A. Abo-Ismael, "Intelligent Control of A Level Process By Employing Variable Strcure Theory", *Proceeding of International Conference in The Mechanical Production Engineering*, Warso, Poland, 1998.
- [8] Ayman A. Aly, Aly S. Abo El-Lail, Kamel A. Shoush and Farhan A. Salem "Intelligent PI Fuzzy Control of An Electro-Hydraulic Manipulator" *I.J. Intelligent Systems and Applications*, 7, 43-49, 2012.
- [9] Sepehri, N., Lawrence, P.D., Sassani, F., and Frenette, R., "Resolved-Mode Teleportation Control of Heavy-Duty Hydraulic Machines", *ASME Journal of Dynamics Systems, Measurement and Control*, V116, N2, pp 232-240, 1994.
- [10] Ayman A. Aly, and H. Ohuchi "Fuzzy Hybrid Control Using Indirect Inference Control For Positioning An Electro-Hydraulic Cylinder", *Conference of Fluid Power System*, Yamaguchi, JAPAN, 2001.
- [11] Wilson J. Rugh, "Analytical Framework for Gain scheduling", *American Control Conference*, San Diego, California, USA, May 1990.
- [12] Ziegler, J. G., & Nichols, N. B., "Optimum Settings for Automatic Controllers", *Transactions of ASME*, 64, pp 759-768, 1942.

Appendix-A: The Hydraulic Crane Geometric Transformation

For the kinematics analysis [3], the schematic representation of the hydraulic crane is illustrated in Fig.A.1.

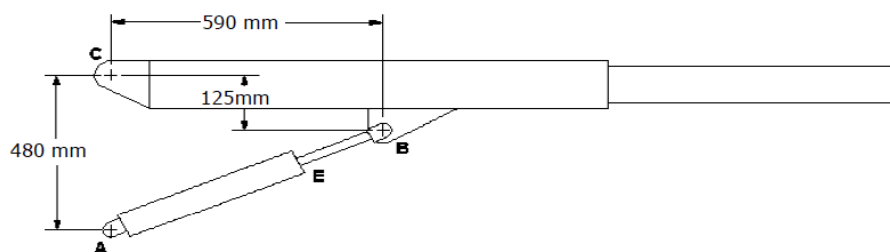

Fig. A.1: Linkage dimensions of consequence

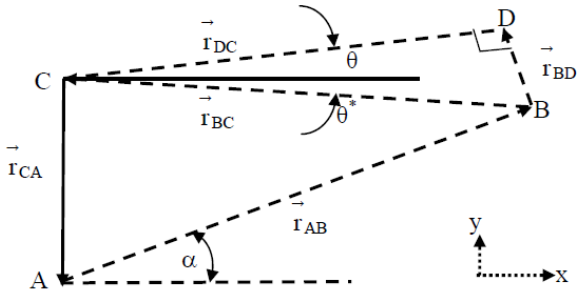

Fig. A.2: Vector representation of linkages

Since the two vectors, \vec{r}_{DB} and \vec{r}_{CD} were of fixed length and were rigidly connected at point D, they were combined. The reference angle, θ , was adjusted to reflect the orientation of the combined vector and this adjusted value was termed, θ^* . This is shown graphically in Fig.A.2.

Application of the coordinate system indicated in Fig.A.2 yields,

$$l_{AB}(\hat{i} \cos \alpha + \hat{j} \sin \alpha) + l_{BC}(-\hat{i} \cos \theta^* - \hat{j} \sin \theta^*) + l_{CA}(-\hat{j}) = 0 \quad (\text{A-1})$$

The unknown quantity, α , was found in terms of the other two unknowns, l_{AB} and θ^* , by first collecting terms containing α on the left hand side,

$$\alpha = a \tan \left(\frac{l_{BC} \sin \theta^* + l_{AC}}{l_{BC} \cos \theta^*} \right) \quad (\text{A-2})$$

The length of the actuator, l_{AB} , as a function of the angular displacement of the boom, θ^* , was then found through substitution of Equation A.2 into Eq.(A.1):

$$l_{AB} = \frac{l_{BC} \cos \theta^*}{\cos \left[a \tan \left(\frac{l_{BC} \sin \theta^* + l_{AC}}{l_{BC} \cos \theta^*} \right) \right]} \quad (\text{A-3})$$

Also a similar velocity analysis was performed in order that the angular velocity of the crane arm could be related to the velocity of the hydraulic actuator as follows, [3]:

$$\dot{l}_{AB} = \dot{\theta} l_{BC} \sin \left[\frac{\pi}{2} - \sin^{-1} \left(\frac{l_{BC}}{l_{AB} \sin \left(\frac{\pi}{2} + \theta^* \right)} \right) \right] - \theta^* \quad (\text{A-4})$$

Appendix-B: System Physical Parameters

Parameters	Values	Units
Torque motor gain of servo valve, k_v	3.75×10^{-4}	m/mA
Natural frequency of servo valve, ω_v	1068	rad/sec
Damping ratio of servo valve, ζ_v	0.5	-
Rated flow rate of serve valve, Q_v	0.333×10^{-3}	m ³ /sec
Total leakage coefficient, C_t	1.0×10^{-10}	m ⁵ /(sec N)
Supply pressure, P_s	140	bar
Bulk module of oil, B	7.0×10^8	Pa
Mass density of oil, ρ	900.0	kg /m
Equivalent mass of both the load and the piston, M_e	100	kg
Diameter of rod, d_{rod}	0.12	m
Diameter of piston, d_{piston}	0.14	m
Max. stroke of cylinder, X_p	1.2	m
Length of pipeline and hoses from pump to cylinder, L	5.0	m
Cylinder Coulomb friction force, F_c	200	N

Biographical notes:



Ayman A. Aly holds a BSc with excellent honour degree (top student) in 1991, MSc in Sliding Mode Control from Mechanical Engineering Department, Assiut University, Egypt in 1996 and PhD in Adaptive Fuzzy Control from Yamanashi University, Japan in

2003. He was an Assistant Professor at Assiut University from 2003–2008. Currently, he is an

Associate Professor and the Head of Mechatronics Engineering Section at Taif University, Saudi Arabia.

In additions to 5 text books, Ayman A. Aly is the author and coauthor of more than 55 scientific papers in Refereed Journals and International Conferences. He supervised some of MSc. and PhD. Degree Students. His main areas of research interests are Intelligent Control of Mechatronics systems, Automotive control systems, Thermofluid systems modeling and simulation.