

## Modeling of Photovoltaic Panel and Examining Effects of Temperature in Matlab/Simulink

S. Rustemli, F. Dincer

*Department of Electrical and Electronics Engineering, Faculty of Engineering and Architecture, Yuzuncu Yil University, 65080, Van/Turkey, phone: +90 432 225 17 33, e-mails: sabirrustemli@yyu.edu.tr, furkandincer@yyu.edu.tr*

### Introduction

The World Energy Forum has predicted that fossil-based oil, coal and gas reserves will be exhausted in less than another 10 decades. Fossil fuels account for over 79% of the primary energy consumed in the world, and 57.7% of that amount is used in the transport sector and are diminishing rapidly. The exhaustion of natural resources and the accelerated demand of conventional energy have forced planners and policy makers to look for alternate sources. Renewable energy is energy derived from resources that are regenerative, and do not deplete over time [1]. Concern about the development of applications of, and the teaching about, renewable energies have increased markedly in recent years [2].

The sun is regarded as a good source of energy for its consistency and cleanliness, unlike other kinds of Energy such as coal, oil, and derivations of oil that pollute the atmosphere and the environment. Most scientists, because of the abundance of sunshine capable of satisfying our energy needs in the years ahead, emphasize the importance of solar energy [3]. Solar energy is obviously environmentally advantageous relative to any other renewable energy source, and the linchpin of any serious sustainable development program. It does not deplete natural resources, does not cause CO<sub>2</sub> or other gaseous emission into air or generates liquid or solid waste products. Concerning sustainable development, the main direct or indirectly derived advantages of solar energy are the following; no emissions of greenhouse (mainly CO<sub>2</sub>, NO<sub>x</sub>) or toxic gasses (SO<sub>2</sub>, particulates), reclamation of degraded land, reduction of transmission lines from electricity grids, increase of regional/national energy independence, diversification and security of energy supply, acceleration of rural electrification in developing countries [4]. Moreover, solar energy is a vital that can make environment friendly energy more flexible, cost effective and commercially widespread. Photovoltaic source are widely used today in many applications such as battery charging, water heating system, satellite power system, and others [5]. Recently, researchers have strongly

promoted the use of solar energy as a viable source of energy. Solar energy possesses characteristics that make it highly attractive as a primary energy source that can be integrated into local and regional power supplies since it represents a sustainable environmentally friendly source of energy that can reduce the occupants' energy bills [6].

Solar radiation is available at any location on the surface of the earth [7]. The energy intensity of the sun to the world, the atmosphere on the kW per square meter is about 1.35. The diameter of the footprint area of the world from the solar power density is  $178 \times 10^6$  MW. The entire surface of the world's solar energy falling is  $1.22 \times 10^{14}$  TCE (tons coal equivalent) in one year, or as imposing size is  $0.814 \times 10^{14}$  TOE (tons of oil equivalent). In other words, the amount of incoming solar energy in one year, fifty times the known reserves of coal, 800 times the known oil reserves [8].

Photovoltaic systems are provided to active using of solar energy. As a solution for the depletion of conventional fossil fuel energy sources and serious environmental problems, focus on the photovoltaic (PV) system has been increasing around the world [9]. The photovoltaic (PV) field has given rise to a global industry capable of producing many gigawatts (GW) of additional installed capacity per year [10]. Solar photovoltaic (PV) market installations reached a record high of 7.3 gigawatt (GW) in 2009, representing growth of 20% over the previous year. The PV industry generated \$38.5 billion in global revenues in 2009, while successfully rising over \$13.5 billion in equity and debt, up 8% on the prior year [11].

### Photovoltaic modules for electricity generation

One important way to convert solar radiation into electricity occurs by the photovoltaic effect which was first observed by Becquerel. It is quite generally defined as the emergence of an electric voltage between two electrodes attached to a solid or liquid system upon shining light onto this system. Practically all photovoltaic devices incorporate a pn-junction in a semiconductor across which the

photovoltage is developed. These devices are also known as solar Cells. The semiconductor material has to be able to absorb a large part of the solar spectrum. Dependent on the absorption properties of the material the light is absorbed in a region more or less close to the surface. When light quanta are absorbed, electron hole pairs are generated and if their recombination is prevented they can reach the junction where they are separated by an electric field [12]. Fig. 1 shows that typical structure of a photovoltaic module.

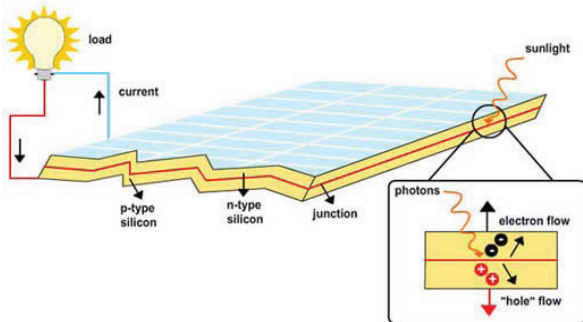

Fig. 1. The photovoltaic effect in a PV cells [13]

To understand the operation of a PV cell, it is need to consider both the nature of the material and the nature of sunlight. PV cells consist of two types of material; p-type silicon and n-type silicon. Light of certain wavelengths is able to ionize the atoms in the silicon and the internal field produced by the junction separates some of the positive charges (holes) from the negative charges (electrons) within the PV device. The holes are swept into the p-layer and the electrons are swept into n-layer. Although these opposite charges are attracted to each other, most of them can only recombine by passing through an external circuit outside the material because of the internal potential energy barrier. Therefore if a circuit as shown in Fig. 1 is composed, power can be produced from the cells under illumination, since the free electrons have to pass through the load to recombine with the positive holes [14].

The photovoltaic module is the result of associating a group of photovoltaic cells in series and parallel, with their protection devices, and it represents the conversion unit in this generation system. The manufacturer supply PV cells in modules, consisting of  $N_{PM}$  parallel branches, each with  $N_{SM}$  solar cells in series, as shown in Fig. 2.

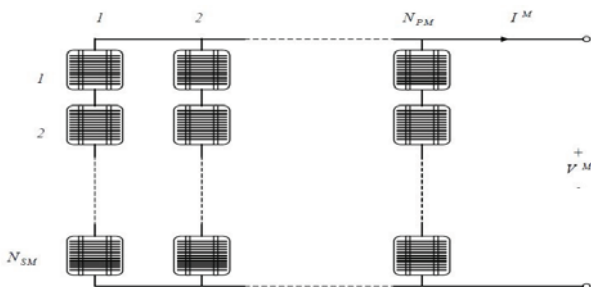

Fig. 2. PV module cell [15]

Although the mathematical and simulation photovoltaic modules development began time ago, improvements of these models are analyzed and presented continually. One of the objectives of this study is a review

of those existing methods and models. Also, a model has been realized in Matlab/Simulink Programme that is based on other existing ones.

### Lorentz La30-12s high - efficiency PV module

The Lorentz LA-Series of PV modules with monocrystalline silicon solar cells offer high conversion efficiency due to the unique back contact technology. Table 1 show that LA30-12S High-efficiency PV Module Parameters. In addition, parameters characterizing PV modules are often hard to come by. Manufacturer's data often provide relatively easy access to parameters such as open circuit voltage, short circuit current and nominal efficiency under standard test conditions (STC) [16]. (1000 W/m<sup>2</sup>, 25 °C, air mass 1.5). But representing accurately the electrical characteristics of the modules from such a small set of parameters, and under a wide range of environmental conditions, is challenging [17].

Table 1. LA30-12S High-efficiency PV module parameters [16]

Peak power	Pmax	[Wp]	30
Tolerance		[%]	+ 15/- 5
Max. power current	Imp	[A]	1.7
Max. power voltage	Vmp	[V]	17.5
Short circuit current	Isc	[A]	1.9
Open circuit voltage	Voc	[V]	21.0
Temperature co-efficient for Pmax	Pmax	[%/°C]	- 0.38
Temperature co-efficient for Voc	Voc	[mV/°C]	- 60.5
Temperature co-efficient for Isc		[mA/°C]	1.8
Max. system voltage		[V]	48
All technical data at standard test condition: AM = 1.5, G = 1,000 W/m <sup>2</sup> , cell temperature: 25 °C			

The low voltage-temperature coefficient guarantees a superior battery charging performance, even at high operating temperatures. Exceptional low-light performance and broad spectral response further enhance energy delivery in all weather conditions, year round [16]. Fig. 3 shows that an example of LA30-12S High-efficiency PV Module.

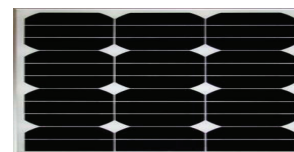

Fig. 3. LA30-12S High-efficiency PV Module [16]

### Modeling of photovoltaic module with using of matlab/simulink

The use of equivalent electric circuits makes it possible to model characteristics of a photovoltaic cell. The method used here is implemented in Matlab/Simulink programs for simulations. The same modeling technique is also applicable for modeling a PV module. There are two key parameters frequently used to characterize a PV cell. Shorting together the terminals of the cell, the photon generated current will follow out of the cell as a short-circuit current ( $I_{SC}$ ). Thus,  $I_{LG}=I_{SC}$ , when there is no

connection to the PV cell (open-circuit), the photon generated current is shunted internally by the intrinsic p-n junction diode. This gives the open circuit voltage ( $V_{OC}$ ). The PV module or cell manufacturers usually provide the values of these parameters in their datasheets [18]. Fig. 4 shows that the well known single diode equivalent circuit model of a photovoltaic cell.

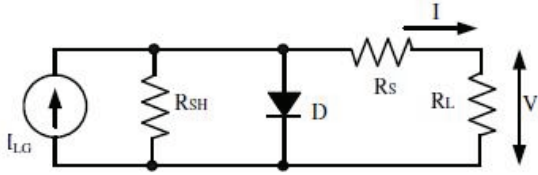

Fig. 4. The circuit diagram of the PV model [19]

Exponential equations for circuit diagram of the PV model [19]:  $k$  – Boltzmann's gas constant;  $1,38 \times 10^{-23}$  J/K;  $T_R$  – Reference temperature of the cell; 300 °K;  $T_P$  – Photovoltaic panel temperature;  $e$  – Electronic charge;  $1,602 \times 10^{-19}$  J/V;  $V$  – Voltage imposed across the cell (V);  $I_{SCR}$  – Short circuit current; under STC;  $I-V$  – Panel output current and voltage;  $I_{OS}$  – Panel dark saturation current, which depends strongly on temperature (A);  $I_{OR}$  – Panel saturation current, which depends on  $T_R$ ;  $K$  – Short circuit temperature coefficient; 0,0017 (A/°C);  $C$  – Solar irradiance (W/m<sup>2</sup>);  $I_{LG}$  – Generating current by solar radiation;  $E_{GO}$  – Band gap voltage; 1.1eV for Si;  $A$  – Diode quality factor; 1,92;  $R_S$  – Series resistance of cell (in ohms);  $R_{SH}$  – Shunt resistance of cell (in ohms).

Capacity of electricity generation from photovoltaic panel depends on many parameters. Two most important parameters which are solar irradiation and panel temperature are discussed for this simulation study. Different radiation and temperature values of the photovoltaic panel were observed to panel voltage and power changes. Maximum power of the PV module was estimated during the simulation from the experimental and formulation relations between the PV module characteristics ( $V_{OC}$ ,  $I_{SC}$ ,  $T_P$ ).

Obtaining parameters from the electrical equivalent diagram of photovoltaic panel; panel output current ( $I$ ), panel dark saturation current ( $I_{OS}$ ) and generating current by solar irradiation ( $I_{LG}$ ) equations show as follows [19]:

$$I = I_{LG} - I_{OS} \left[ \exp\left(\frac{q}{nkT_P}(V + IR_S)\right) - 1 \right] - \frac{V + IR_S}{R_{SH}}, \quad (1)$$

$$I_{OS} = I_{OR} \left(\frac{T_P}{T_R}\right)^3 \exp\left[\frac{qE_{GO}}{Ak} \left(\frac{1}{T_R} - \frac{1}{T}\right)\right], \quad (2)$$

$$I_{LG} = [I_{SCR} + K(T_P - 25)]C/100. \quad (3)$$

Fig. 5 shows the I-V characteristic curve of a solar cell for certain irradiance ( $G$ ) at a fixed cell temperature  $T_P$ . The current from a PV cell depends on the external voltage applied and the amount of sunlight on the cell. When the cell is short-circuited, the current is at maximum (short-circuit current  $I_{SC}$ ), and the voltage across the cell is 0. When the PV cell circuit is open, with the leads not

making a circuit, the voltage is at its maximum (open-circuit voltage  $V_{OC}$ ), and the current is 0 [20].

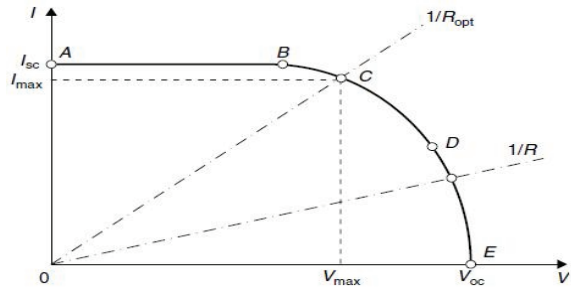

Fig. 5. Representative current-voltage curve for photovoltaic cells [20]

If the cell's terminals are connected to a variable resistance,  $R$ , the operating point is determined by the intersection of the  $I-V$  characteristic of the solar cell with the load  $I-V$  characteristics. As shown in Fig. 5 for a resistive load, the load characteristic is a straight line with a slope  $1/V = 1/R$ . If the load resistance is small, the cell operates in the region  $AB$  of the curve, where the cell behaves as a constant current source, almost equal to the short-circuit current. On the other hand, if the load resistance is large, the cell operates on the region  $DE$  of the curve, where the cell behaves more as a constant voltage source, almost equal to the open circuit voltage. Point  $C$  on Fig. 5 is also called the maximum power point, which is the operating point ( $P_{max}$ ) at which the output power is maximized [20]:

$$P_{max} = I_{max} V_{max}, \quad (4)$$

$$P_{max} = I_{sc} V_{oc} FF, \quad (5)$$

$$FF = \frac{P_{max}}{I_{sc} V_{oc}}. \quad (6)$$

The open circuit voltage corresponds to the voltage drop across the diode when it is traversed by the photocurrent  $I_{LG}$ , which is equal to  $I_{OS}$ , when the generated current is  $I=0$ . It can be solved for  $V_{OC}$  [20]

$$V_{oc} = \frac{kT_R}{e} \ln\left(\frac{I_{sc}}{I_o} - 1\right) = V_t \ln\left(\frac{I_{sc}}{I_o} + 1\right), \quad (7)$$

where  $V_t$  – thermal voltage (V) given by [20]

$$V_t = \frac{kT_R}{e}. \quad (8)$$

All of the constants in the above equations can be determined by examining the manufacturers' ratings of the PV array, and then the published or measured I-V curves of the array. These formulations are used with Matlab/Simulink programme for obtaining this experimental study.

The theory of the photovoltaic cell is the photovoltaic effect of semiconductor material. The photovoltaic effect is a phenomenon that the semiconductor material absorbs the

solar energy, and then the electron-hole excited by the photon separates and produces electromotive force. The I-V characteristic of the photovoltaic cell changes with the sunshine intensity  $G$  ( $\text{W}/\text{m}^2$ ) and cell temperature  $t$  ( $^\circ\text{C}$ ), that is  $I = f(V, G, t)$  [21].

Linear regression to the test data of PV module temperature ( $T_p$ ) versus open circuit voltage ( $V_{OC}$ ) is found by [22]

$$V_{OC} = 22.384 - 0.0627 T_p, \quad (9)$$

where  $T_p$  is in  $^\circ\text{C}$ .

Also, the linearity between solar radiation ( $G$ ) and short circuit current ( $I_{SC}$ ) data is represented by [22]

$$I_{SC} = 0.0967 + 0.0032G, \quad (10)$$

where  $G$  is in  $\text{W}/\text{m}^2$ .

Change of module temperature with ambient temperature can be expressed by the following linearity [22]

$$T_p = T_A + \left( \frac{T_p - T_A}{G} \right)_{s \tan dard} * G. \quad (11)$$

The value of the bracket depends on the type of PV module. This value was found equal to  $0.022 \text{ }^\circ\text{Cm}^2/\text{W}$  from tests at normal operating condition. However when the PV module water cooling technique was applied, the value of the bracket was found equal to  $0.006 \text{ }^\circ\text{C m}^2/\text{W}$  [22].

Solar radiation is the first and temperature is the second most important effect. So, this study is examined these important effecting parameters. Typically voltage decreases with increasing temperature, and current increases (although slightly), the combined effect being that power decreases. For instance; a polycrystalline module operating typically at  $45 \text{ }^\circ\text{C}$  will therefore produce roughly 10% less power than predicted by its nominal standart test conditions rating [17].

### Calculations of the pv solar module characteristics curves

The parameters that determine the operation of a photovoltaic panel reflected in their characteristic curves, I-V and P-V. Fig. 6 shows that modeling of a photovoltaic panel and represents and Fig. 7 represents that the calculation of two groups of curves, first the temperature stayed constant at  $25 \text{ }^\circ\text{C}$  varying the different irradiance ( $700, 800, 900$  and  $1000 \text{ W}/\text{m}^2$ ) generating a type of curves. Later, the irradiance is maintained constant at  $1000 \text{ W}/\text{m}^2$  calculating the curve for different temperatures ( $25, 50$  and  $75 \text{ }^\circ\text{C}$ ).

Moreover, Fig. 9 shows that the current – voltage curves relations at various solar irradiances are obtained for photovoltaic panel working. For a radiation level between  $400\text{--}1000 \text{ W}/\text{m}^2$ , PV module output increases in the range 4–10% [22]. The Fig. 10-11-12, show that power - voltage curves for different temperature values, again the discrete data points taken directly from the manufacturer's published curves, and show excellent correspondence to

the model. All of these are done at various photovoltaic panel temperature values are introduced.

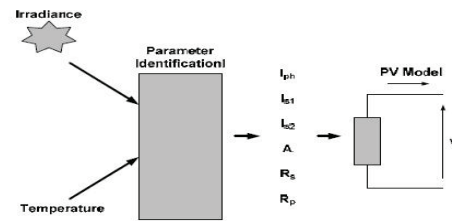

Fig. 6. Modeling of a PV panel [18]

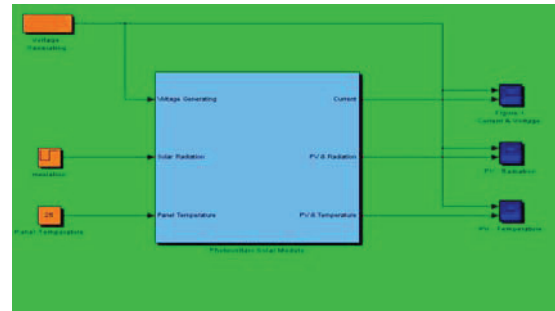

Fig. 7. Operational functional block diagram of the photovoltaic panel with environmental factors

Fig. 8 shows that content of operational functional block diagram. Indicated modeling stages is designed according to the photovoltaic solar formulations and results are observed.

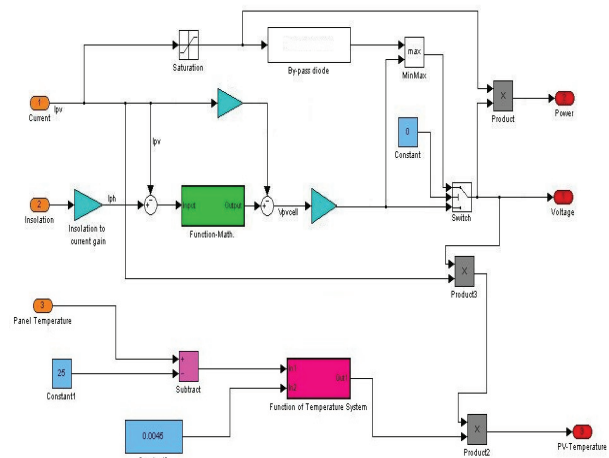

Fig. 8. Modeling stage

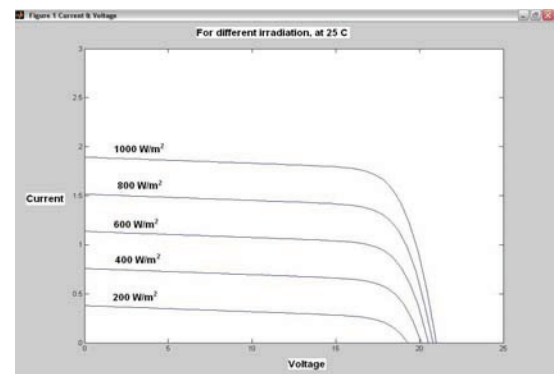
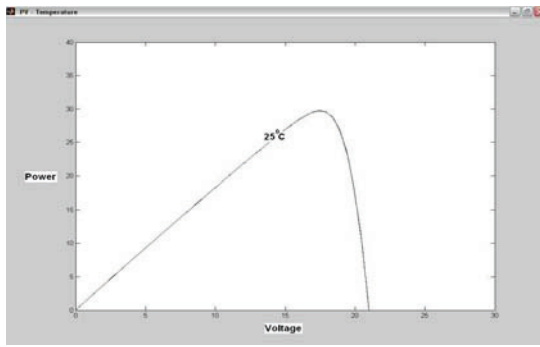

Fig. 9. Matlab model I-V curve for  $T_p=25 \text{ }^\circ\text{C}$ ,  $G = 1000; 800; 600; 400; 200 \text{ W}/\text{m}^2$





**Fig. 10.** Matlab model P-V curve for under conditions  $G=1000$   $W/m^2$  and  $T_p=25$   $^{\circ}C$

Obtained parameter values:  $T_p=25$   $^{\circ}C$  ;  $V_{OC}=20,81$ ;  
 $P_{max}=30$

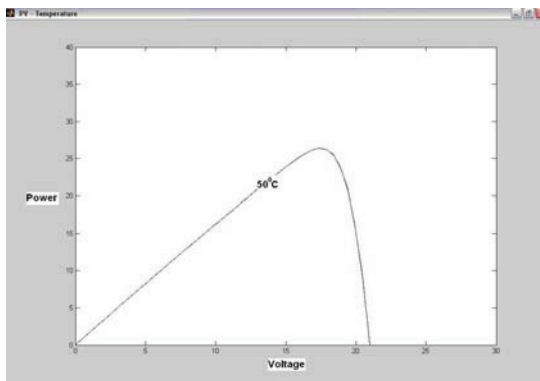

**Fig. 11.** Matlab model P-V curve for under conditions  $G=1000$   $W/m^2$  and  $T_p=50$   $^{\circ}C$ .

Obtained parameter values:  $T_p=50^{\circ}C$ ;  $V_{OC}=19,24$ ;  
 $P_{max}=26,62$

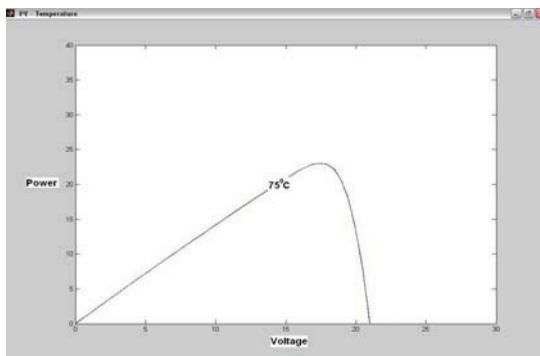

**Fig. 12.** Matlab model P-V curve for under conditions  $G= 1000$   $W/m^2$  and  $T_p=75$   $^{\circ}C$ .

Obtained parameter values:  $T_p=75$   $^{\circ}C$ ;  $V_{OC}=17,68$ ;  
 $P_{max}=23,25$

During selection of the panel, also the effect of temperature on the panel can be evaluated. Module output power reduces as module temperature increases [23]. This simulation study results supports this claim. Indicated curves show that  $P_{max}$  changes from 30 watt to 23,25 watt as  $T_p$  changes from 25 to 75 $^{\circ}C$ . A schematic representation of the simulation results is as shown in fig. 13.

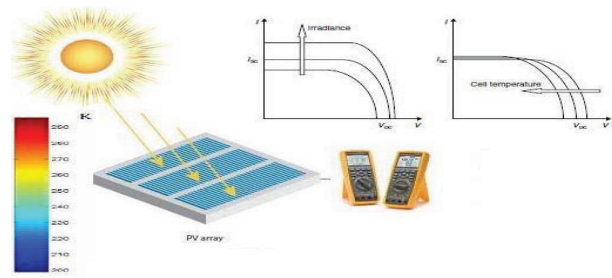

**Fig. 13.** A schematic representation of the simulation results

## Conclusions

An accurate photovoltaic module electrical model is presented and demonstrated in Matlab/Simulink for a typical Lorentz LA30-12S photovoltaic panel. Such a generalized PV model is easy to be used for the implementation on Matlab/Simulink modeling and simulation platform. Especially, in the context of the Sim Power System tool, there is now a generalized PV model which can be used for the model and analysis in the filed of solar PV power conversion system [24]. Given solar irradiance and panel temperature, the model returns an I-V and P-V graphics. Obtained panel parameters from Lorentz LA30-12S photovoltaic panel is implemented Matlab/Simulink program and a special photovoltaic panel function is created. Therefore, simulation results show that a photovoltaic panel output power reduces as module temperature increases. This situation is showed with Matlab/Simulink graphics. There are lots of variety cooling systems for photovoltaic panels. These systems may increase efficiency of panel depend on the weather conditions.

## References

1. **Kumar A., Kumar K., Kaushik N., Sharma S., Mishra S.** Renewable energy in India: Current status and future Potentials // Renewable and Sustainable Energy Reviews. – Elsevier, 2010. – No. 14(8). – P. 2434–2442.
2. **Gomez-Amo J. L., Tena F., Martı́nez-Lozano J. A., Utrillas M. P.** Energy saving and solar energy use in the University of Valencia (Spain) // Renewable Energy. – Elsevier, 2004. – No. 29(5). – P. 675–685.
3. **Rustemli S., Dincadam F., Demirtas M.** Performance Comparison of the Sun Tracking System and Fixed System In The Application of Heating and Lighting // The Arabian Journal for Science and Engineering. – King Fahd University of Petroleum & Minerals, 2010. – No. 35(2B). – P. 171–183.
4. **Wang Q., Qiu H. N.** Situation and outlook of solar energy utilization in Tibet, China // Renewable and Sustainable Energy Reviews. – Elsevier, 2009. – No. 13(8). – P. 2181–2186.
5. **Hossain E., Muhida R., Ali A.** Efficiency Improvement of Solar Cell Using Compound Parabolic Concentrator and Sun Tracking System // Electrical Power and Energy Conference. – IEEE Canada and the IEEE Vancouver Section, 2008. – P. 1–8.
6. **Hassan M. M., Beliveau Y.** Modeling of an integrated solar system // Building and Environment. – Elsevier, 2008. – No. 43(5). – P. 804–810.
7. **Akpınar A., Kōmürçü M. İ., Kankal, M., Özölçer İ. H., Kaygusuz K.** Energy situation and renewables in Turkey and environmental effects of energy use // Renewable and

- Sustainable Energy Reviews. – Elsevier, 2008. – No. 12(8). – P. 2013–2039.
8. **Özgöçmen A.** Electricity Generation Using Solar Cells, MSc. Thesis. – Gazi University, 2007. – 97 p.
  9. **So J., H., Jung Y., S., Yu G., J., Choi J., Y., Choi J.** Performance results and analysis of 3 kW grid-connected PV systems // *Renewable Energy*. – Elsevier, 2007. – No. 32(11). – P. 1858–1872.
  10. **Vasarevičius D., Martavičius R.** Solar Irradiance Model for Solar Electric Panels and Solar Thermal Collectors in Lithuania // *Electronics and Electrical Engineering*. – Kaunas: Technologija, 2011. – No. 2(108). – P. 3–6.
  12. **Çapar Ş.** Photovoltaic Power Generation for Polycrystalline Solar Cells and Turning Sunlight Into Electricity, MSc. Thesis. – University of Gaziantep, 2005. – 53 p.
  13. **Miedzinski B., et al.** Autonomous Monitoring System of Environment Conditions // *Electronics and Electrical Engineering*. – Kaunas: Technologija. – 2010. – No. 5(101). – P. 63–66.
  14. **Balčiūnas P., Norkevičius P.** Stochastic Nature Electrical Energy Conversion Processes Experimental Research of Wind Micro Power Plant // *Electronics and Electrical Engineering*. – Kaunas: Technologija, – 2010. – No. 9(105). – P. 57–60.
  15. **Hansen A. D., Sorensen P., Hansen L. H., Bindner H.** Models for a stand alone PV system. – Riso National Laboratory, 2000. – 78 p.
  16. **Lorentz La30-12s High - Efficiency PV Module.** Online: [www.lorenz.de](http://www.lorenz.de).
  17. **Thevenard D.** Review and Recommendations for Improving the Modelling of Building Integrated Photovoltaic Systems // *Ninth International Ibpsa Conference Montréal. – Building Simulation*, 2005. – P. 1221–1228.
  18. **El Shahat A.** PV Cell Module Modeling & Ann Simulation For Smart Grid Applications // *Journal of Theoretical and Applied Information Technology*. – Little Lion Scientific Islamabad Pakistan, 2010. – No. 16(1). – P. 9–20.
  19. **Demirtaş M.** Design and Implementation of PLC Controlled Solar Tracking System // *e-Journal of New World Sciences Academy*, 2009. – No. 4(3) – P. 315–329.
  20. **Kalogirou S.** Solar Energy Engineering: Processes and Systems. – Academic Press, 2009. – 48p.
  21. **Xiujuan M., Yude S., Jiayu W., Shiqiang L.** The Research on the Algorithm of Maximum Power Point Tracking in Photovoltaic Array of Solar Car // *Vehicle Power and Propulsion Conference*. – Dearborn, MI, 2009. – P. 1379–1382.
  22. **Odeh S., Behnia M.** Improving Photovoltaic Module Efficiency Using Water Cooling // *Heat Transfer Engineering*. – Taylor & Francis, 2010. – No. 30(6) – P. 499–505.
  23. **Ramonas Č., Adomavičius V., Gečys S.** Research of Harmonic Minimization Possibilities in Grid-tied Photovoltaic System // *Electronics and Electrical Engineering*. – Kaunas: Technologija, 2010. – No. 1(107). – P. 83–86.
  24. **Tsai H.-L., Tu C.-S., Su Y.-J.** Development of Generalized Photovoltaic Model Using Matlab/Simulink // *Proceedings of the World Congress on Engineering and Computer Science*. – San Francisco, USA, 2008. – P. 846–851

Received 2011 01 18

**S. Rustemli, F. Dincer. Modeling of Photovoltaic Panel and Examining Effects of Temperature in Matlab/Simulink // Electronics and Electrical Engineering. – Kaunas: Technologija, 2011. – No. 3(109). – P. 35–40.**

This study proposes general and specific modeling and simulation for Lorentz LA30-12S photovoltaic panel. This panel has monocrystalline cell technology. The panel power parameters are examined under observing different panel temperatures. It is created a special function for this system by Matlab/Simulink programmer. Also, the different solar radiation values are taken into account. The model for the proposed range of irradiance and temperature as model inputs, with the corresponding values of voltages, currents, and power as outputs is presented. Simulation results are compared by doing power calculations. The simulation results show that a photovoltaic panel output power reduces as module temperature increases. This situation is showed with Matlab/Simulink graphics. Ill. 13, bibl. 24, tabl. 1 (in English; abstracts in English and Lithuanian).

**S. Rustemli, F. Dincer. Plokštės, sudarytos iš fotogalvaninių elementų, temperatūros poveikio tyrimas modeliuojant programų paketu Matlab/Simulink // Elektronika ir elektrotechnika. – Kaunas: Technologija, 2011. – Nr. 3(109). – P. 35–40.**

Lorentz LA30-12S plokštė, sudaryta iš fotogalvaninių elementų. Išanalizuoti galios parametrai įvertinant temperatūros poveikį. Tam tikslui programų paketui Matlab sudaryta paprogramė. Pasiūlytame modelyje įvertintas saulės spindulių intensyvumo poveikis ir apskaičiuoti pagrindiniai parametrai. Modeliavimo metu gauti rezultatai palyginti apskaičiuojant galią. Nustatyta, kad tokios plokštės išėjimo galia mažėja kylant temperatūrai. Pateikti grafikai. Il. 13, bibl. 24, lent. 1 (anglų kalba; santraukos anglų ir lietuvių k.).