

## **MODELING OF SHIELDING COMPOSITE MATERIALS AND STRUCTURES FOR MICROWAVE FREQUENCIES**

**M. Y. Koledintseva, J. Drewniak, and R. DuBroff**

EMC Laboratory, ECE Department  
Missouri University of Science and Technology (MS&T)  
Rolla, MO 65409, USA

**K. Rozanov**

Institute for Theoretical and Applied Electromagnetics  
Russian Academy of Sciences  
Moscow, Russia

**B. Archambeault**

IBM Co. Research  
Triangle Park, NC, USA

**Abstract**—Composites containing conducting inclusions are required in many engineering applications, especially, for the design of microwave shielding enclosures to ensure electromagnetic compatibility and electromagnetic immunity. Herein, multilayer shielding structures are studied, with both absorbing and reflecting composite layers. In this paper, fiber-filled composites are considered. For modeling absorbing composites with low concentration of conducting cylindrical inclusions (below the percolation threshold), the Maxwell Garnett theory is used. For reflecting layers, when concentration of inclusions is close to or above the percolation threshold, the McLachlan formulation is used. Frequency dependencies for an effective permittivity are approximated by the Debye curves using a curve-fitting procedure, in particular, a genetic algorithm.

## 1. INTRODUCTION

Electromagnetic shielding is frequently used to reduce emissions or improve immunity of electronic equipment. Often enclosures of electronic equipment are made of highly-conducting metal to achieve the required shielding. However, requirements to reduce the size and weight of electronic devices necessitate substitution of metal by conducting polymers and composites [1–4]. These composites may contain metal or carbon particles [5, 6]. Carbon-fiber laminate woven materials are known to be used for shielding purposes [7, 8]. The integrity of any shielding enclosure is compromised by the presence of slots and aperture arrays for heat dissipation and other purposes [9]. If currents flowing on conducting surfaces of an enclosure cross these slots or apertures, they become unintentional antennas. One of the ways to eliminate this problem is to use absorbing dielectric materials to design shielding enclosures. Composite dielectric materials that contain randomly distributed conductive inclusions, including carbon fibers, at small concentrations can be used for absorbing electromagnetic waves at RF and microwave frequencies [10–12]. Recently, interest in carbon-containing composite materials for RF and microwave applications has increased, especially due to the progress of nanotechnology and availability of carbon nanotubes and nanowires [13–16].

The present paper deals with composite carbon-fiber filled materials and multilayered structures on their base. Depending on the concentration of conducting inclusions, composite materials can either absorb or reflect electromagnetic waves. If several layers of different composite materials are stacked up, it is possible to shape the frequency response of the material as desired. This means that one can control shielding effectiveness (S.E.) in the frequency range of interest by loading layers of composite materials with different concentrations and types of inclusions, and then stack them in an appropriate order. Typically, at higher frequencies the composite materials give the required electromagnetic shielding due to absorption and, hence, the shielding depends on the thickness of the composite material. At lower frequencies, shielding effectiveness may be improved by the presence of conducting layers. Analytical and numerical modeling of frequency response for a desired composite material prior to manufacturing and testing of multiple materials will save resources and time for the development cycle.

The structure of the paper is as follows. Section 2 contains the mathematical model of the composite. Material properties chosen for the modeling are described in Section 2. The results of full-wave numerical (EZ-FDTD) simulations for shielding enclosures with single-

layered composite material and multilayered materials are presented in Sections 4 and 5, respectively. The conclusions are summarized in Section 6.

## 2. COMPOSITE MATERIAL MODEL

Composite materials with conducting fibers have a frequency-dependent effective permittivity. An advantage of using carbon fibers in composite materials is that its range of pronounced frequency dispersion is shifted to the RF and lower frequency portion of the microwave band [17]. To characterize electromagnetic properties of composite media, it is important to know the electromagnetic parameters of a host (matrix, base) material and inclusions. There are many effective media theories (EMT) allowing for homogenization of composite media [18–24]. The effective parameters of composites obtained from any applicable effective medium formulation can serve as a basis for the engineering of composite microwave materials. Their frequency responses can be calculated using parameters of the particular dielectric base and inclusion materials available from experimental measurements, manufacturer's, or reference data published independently. This means that mathematical modeling based on mixing formulas should provide an efficient tool for the analysis of the frequency behavior of a composite depending on the physical properties and geometry of its constituents.

The Maxwell Garnett (MG) model [24] is the simplest and the most widely used. It is applicable for multiphase mixtures, and allows frequency characteristics being represented in the form of rational-fractional functions convenient for incorporating in numerical time-domain electromagnetic codes [25]. An important limitation of the MG model is that it can be used only for comparatively low concentrations of conducting inclusions (well below the percolation threshold). The percolation threshold in a conductor-insulator composite material is defined as the concentration of the conductive inclusions, where electrical properties of the composite change drastically from insulator to conductor. For composite materials with the concentration of the conductive inclusions around the percolation threshold, the effective permittivity can be obtained from the McLachlan's effective medium theory [26].

A design flowchart for multilayered shielding structures made of composite materials is shown in Figure 1. The S.E. of electromagnetic structures made of composite panels with slots and apertures can be evaluated using 3D full-wave numerical modeling tools. The frequency-dependent properties of composite materials can be loaded into the

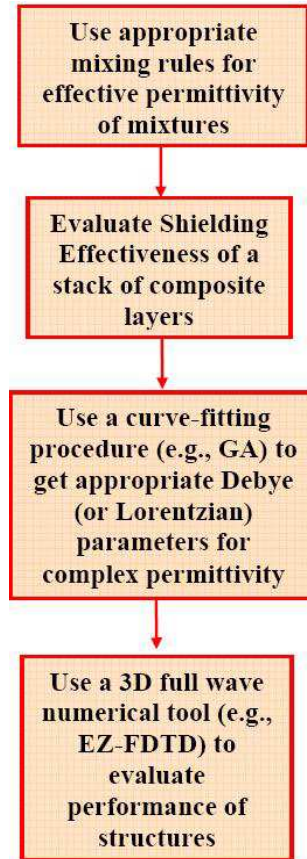

**Figure 1.** Design flowchart to design a shielding enclosure using composite materials.

3D full-wave simulation tools using equivalent effective parameters approximated by the appropriate Debye or Lorentzian parameters or a sum of Debye-like terms [27]. These Debye or Lorentzian parameters can be used in such full-wave tools as EZ-FDTD, based on finite-difference time-domain technique (FDTD), or CST Microwave Studio.

Frequency-dependent material properties can be approximated by a single Debye term, or a sum of Debye-like terms using different curve-fitting optimization techniques. One of them is a Genetic Algorithm (GA) [27]. The GA can be used to optimize the properties of the composite materials to achieve the required shielding effectiveness. If a shielding structure is comprised of two or more layers of composite and/or conventional materials, the overall transmission and reflection

responses of the stack of layers can be calculated from the ABCD matrices, corresponding to each of the layers, and these matrices must be combined to obtain the ABCD matrix of the entire system. Then the reflection and transmission coefficients, as well as the corresponding shielding effectiveness of the structure can be evaluated using the overall ABCD matrix of the system [28, 29].

Relative permittivities of the base and inclusions can be complex functions of frequency. The Maxwell Garnett multiphase formula for composites with concentration of conducting inclusions below the percolation threshold is [18, 30, 31]

$$\varepsilon_{eff} = \varepsilon_b + \frac{\frac{1}{3} \sum_{i=1}^n v_i (\varepsilon_i - \varepsilon_b) \sum_{k=1}^3 \frac{\varepsilon_b}{\varepsilon_b + N_{ik}(\varepsilon_i - \varepsilon_b)}}{1 - \frac{1}{3} \sum_{i=1}^n v_i (\varepsilon_i - \varepsilon_b) \sum_{k=1}^3 \frac{N_{ik}}{\varepsilon_b + N_{ik}(\varepsilon_i - \varepsilon_b)}}, \quad (1)$$

where  $\varepsilon_b$  is the relative permittivity of a base dielectric;  $\varepsilon_i$  is the relative permittivity of the  $i$ -th type of inclusions;  $v_i$  is the volume fraction occupied by the inclusions of the  $i$ -th type;  $N_{ik}$  are the depolarization factors of the  $i$ -th type of inclusions, and the indices  $k = 1, 2, 3$  correspond to  $x, y$ , and  $z$  Cartesian coordinates.

McLachlan's equation is suitable for the describing effective parameters of the mixture close to or above the percolation threshold is [32]

$$\frac{(1 - v_i) \left( \varepsilon_b^{1/s} - \varepsilon_{eff}^{1/s} \right)}{\varepsilon_b^{1/s} + \left( \frac{1-p_c}{p_c} \right) \varepsilon_{eff}^{1/s}} + \frac{v_i \left( \varepsilon_i^{1/t} - \varepsilon_{eff}^{1/t} \right)}{\varepsilon_i^{1/t} + \left( \frac{1-p_c}{p_c} \right) \varepsilon_{eff}^{1/t}} = 0, \quad (2)$$

where the values  $s$  and  $t$  are the so-called process exponents. The ratio of these exponents  $s/t$  determines the symmetry of the real and imaginary part of the permittivity around the percolation threshold  $p_c$ . According to [33, 34], the percolation threshold for long fibers with an aspect ratio  $a = l/d \gg 1$ , where  $l$  is the average length of fibers in the mixture, and  $d$  is their average diameter, is inverse proportional to the aspect ratio of inclusions,  $p_c \propto 1/a$ . Measurement results reported in [35] on carbon-fiber-filled composites with properties close to the abovementioned demonstrate the similar behavior  $p_c \approx 1/a$ . Therefore, based on the assumption that the fibers are randomly distributed in the volume of the host material, it can be expected that Equation (2) should be valid for aspect ratios approximately from 0.1 to 1000, close to the percolation threshold.

### 3. MATERIAL PROPERTIES CHOSEN FOR MODELING

In this Section, only absorbing layers containing carbon fibers are considered. This means that these materials remain dielectrics containing low concentrations of carbon fibers.

#### 3.1. Host Material Properties

Different polymer materials, such as Teflon or thermoplasts, can be used as the base material (host matrix) for design of shields for microwave frequencies (100 MHz–10 GHz). Teflon [36] is almost non-dispersive in the frequency range of interest, and its loss factor can be neglected. The dielectric constant of the Teflon in our computations is taken as 2.2.

#### 3.2. Properties of Conducting Inclusions

It is known that carbon composites are extensively used in the aerospace industry. For this reason, carbon fiber inclusions are selected to ensure that the processes involved in manufacturing of these composites are relatively known and cheap. Carbon fibers have a wide range of conductivities, diameters, and lengths (depending on manufacturers). For getting good shielding effectiveness in the frequency range of interest, it is necessary that the composites have proper values of conductivity and aspect ratio to absorb the electromagnetic waves in this frequency range.

#### 3.3. Properties of a Composite

The electromagnetic shielding effectiveness is achieved using low concentration of carbon fibers with relatively high aspect ratio. The optimization of properties of the carbon fiber-Teflon composite from the point of view of the highest average electromagnetic shielding effectiveness in the frequency range of interest can be found using the GA. The mechanism of shielding is mainly absorption of electromagnetic waves by conducting inclusions, and the absorption is proportional to the thickness of the composite material. Herein, 10-mm thick composite layer is taken in the GA optimization.

Since the concentration of carbon should be lower than the percolation threshold (dilute conductive phase), MG mixing theory is applied to obtain the effective permittivity. Also, since the diameter of the fibers is assumed to be much smaller than the skin depth at frequencies below 10 GHz, which is the frequency range of interest, the skin effect (eddy currents) in carbon fibers is neglected.

Figure 2 shows the permittivity of the composite obtained using the MG formula. For these calculations, carbon fiber conductivity was taken 70000 S/m; the aspect ratio of inclusions was 800; volume fraction of carbon fibers was 0.07%, while the lowest percolation threshold was estimated as  $p_c = 1/a = 0.00125 = 0.125\%$ . If the percolation threshold is estimated as  $p_c = 4.5/a$  [33], it would be around 0.56%, as given in Table 1.

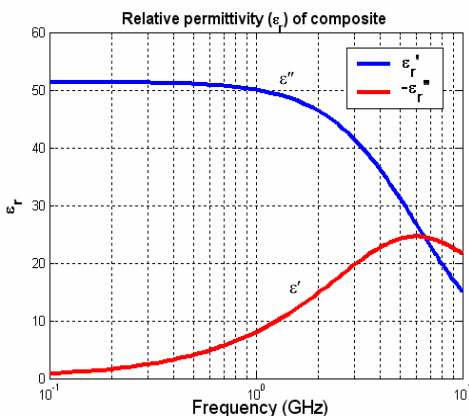

Figure 2. Permittivity properties of the composite.

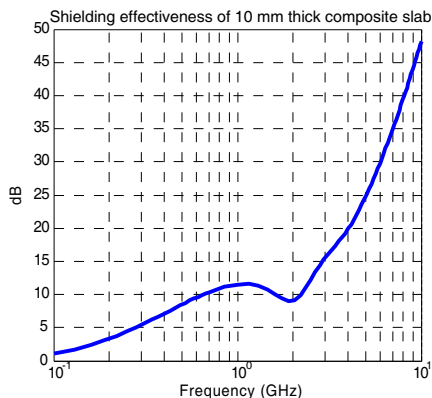

Figure 3. Shielding effectiveness of composite slab with parameters corresponding to Figure 2.

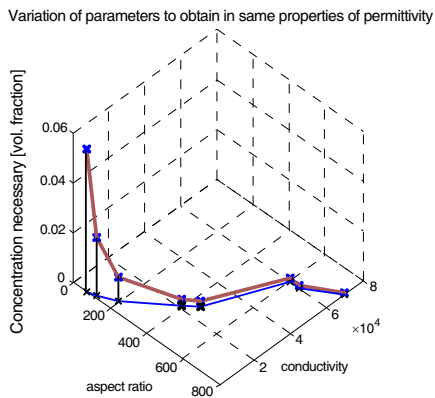

Figure 4. Variation of carbon-fiber parameters: Aspect ratio, conductivity (S/m), and volume fraction (%), to obtain the same permittivity as in Figure 2.

The permittivity of the composite exhibits relaxation behavior, which can be approximated by the Debye frequency dispersion law.

$$\varepsilon_{eff} = \varepsilon_{\infty} + \frac{\varepsilon_s - \varepsilon_{\infty}}{1 + j\omega\tau_e} + \frac{\sigma}{j\omega\varepsilon_0}, \quad (3)$$

where  $\varepsilon_s$  is the static permittivity,  $\varepsilon_{\infty}$  is the high-frequency limit permittivity;  $\tau$  is the relaxation time; and  $\sigma$  is the d.c. (ohmic) equivalent conductivity. These parameters are called “the Debye parameters”. Actually, there may be several Debye terms describing frequency dependence of a dielectric.

Though the phase of conducting inclusions is very dilute, the effective permittivity of the mixture is much higher than that of the base material. This is because conducting fibers simulate dipoles with high concentration of electric charges at their ends. This leads to the dramatically increased polarizability per unit volume of the mixture and, hence, high permittivities. Shielding effectiveness of the 1-cm thick composite layer calculated through the plane-wave formulation

$$S.E. = -|T|_{dB} = -20 \log_{10} \frac{|E_{trans}|}{|E_{inc}|}, \quad (4)$$

is shown in Figure 3.

Table 1 presents different sets of carbon fiber properties that result in the frequency characteristics for permittivity shown in Figure 2. These sets of parameters have been obtained for the initial frequency dependencies in Figure 2 using the GA optimization technique. The same data is represented in Figure 4 as a 3D and a 2D graphs (aspect ratio, conductivity, and volume fraction) for variation of carbon-fiber parameters.

**Table 1.** Carbon fiber properties for an absorbing layer.

Index	Conductivity [S/m]	Aspect ratio $a=l/d$	Volume fraction percolation threshold $p_c = 4.5/a, \%$	Volume fraction, %
Set 1 (base set)	69998	800.0	0.56	0.070
Set 2	26256	444.5	1.010	0.210
Set 3	21312	391.0	1.151	0.267
Set 4	11000	375.0	1.280	0.322
Set 5	10000	350.0	1.200	0.314
Set 6	8776	301.0	1.500	0.600
Set 7	5827	194.4	2.320	0.949
Set 8	2236	115.5	3.897	2.332
Set 9	933	69.3	6.500	5.710



### 4. 3D FULL-WAVE SIMULATIONS OF SINGLE-LAYER ENCLOSURES

Practical engineering design of devices and structures employing composite materials may need 3D full-wave numerical simulations at the research and developmet stage. Such simulation tools, as HFSS, CST Microwave Studio, EZ-FDTD, etc., require electromagnetic parameters of the materials to be known. HFSS can accept material properties only at discrete frequency points, while CST Microwave Studio and EZ-FDTD can incorporate special materials with Debye or Lorentzian frequency characteristics [37]. The permittivity of the composite material modeled using the MG mixing formula can be represented by the equivalent Debye parameters. The latter can be extracted directly from MG formulation, or can be approximated using the genetic algorithm (GA) or other curve-fitting procedure, if frequency dependence turns out to be complex-shaped, in the general case, for example, for multiphase mixtures [25]. The extracted equivalent Debye curve parameters, corresponding to Figure 2, are the following:  $\epsilon_s = 51.41$ ;  $\epsilon_\infty = 2.22$ ;  $\tau = 2.66 \cdot 10^{-11}$  s; and  $\sigma = 9.59 \cdot 10^{-5}$  S/m. Figures 5(a) and (b) show the input permittivity data of the composite given to the GA program and the curve-fitting data. These extracted Debye parameters are further used in numerical simulations.

The enclosure (a closed box) comprised of a composite material under study has been modeled using the EZ-FDTD codes, and it is shown in Figure 6. The parameters for the FDTD modeling are the

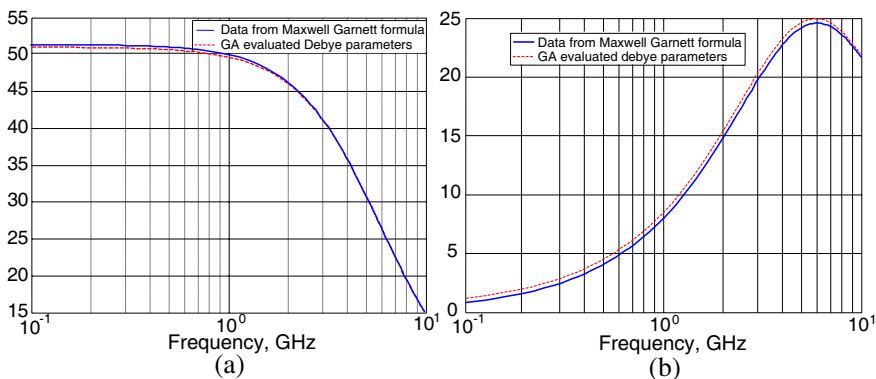

**Figure 5.** Frequency dependencies of the effective permittivity restored from the extracted Debye parameters: (a) real part and (b) imaginary part.

following: the size of the box is  $22\text{ cm} \times 13.5\text{ cm} \times 18\text{ cm}$ ; boundary conditions at infinity are simulated with a perfect matched layer (PML); and the cell size is  $0.15\text{ cm} \times 0.15\text{ cm} \times 0.15\text{ cm}$ . The structure is excited by a current source  $S_1$ , which is the modulated Gaussian source with the spectrum ranging from 100 MHz to 10 GHz. It is important to note that if just a thin-wire source were used, it would produce some undesirable resonances associated with the length of the wire. For this reason, the current source in these simulations is chosen as the “pseudo soft source”, such that its response would be caused only by the shielding box. There are both near-field monitor points (MP) and far-field probes (FD) for the electric field intensity. The radiated electric field is evaluated in the EZ-FDTD at the far field monitor points without the composite enclosure and with it. The dependencies for the maximum radiated in all the directions far-field electric field upon frequency are shown in Figure 7. Shielding effectiveness (S.E.) is found as the ratio of the radiated electric field with the presence of the composite enclosure to that without any enclosure. Thickness of the composite enclosure walls are 10 mm. Figure 8 shows the shielding effect due to the enclosure (EZ-FDTD curve) and the curve obtained in the plane-wave calculations for the composite layer of the same thickness (10 mm). According to speculations about the absorbing nature of the engineered composite, the box made of this composite should have substantially reduced surface currents, and hence, presence of slots will not lead to much unwanted radiation, as it happens with the metal box. In order to evaluate the performance of the composite enclosure with slots, it is compared with an analogous PEC (Perfect Electric Conductor) box with slots. The inner dimensions of the

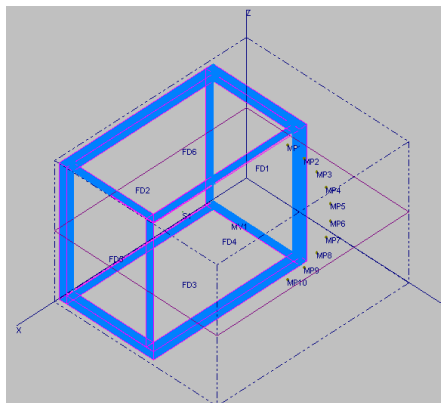

**Figure 6.** Geometry of the enclosure used in the FDTD simulation.

PEC enclosure are the same as that of the composite enclosure shown in Figure 6. Slots are on all the edges of the enclosure, and they are 1 cell wide (1.5 mm). However, two conductive layers are added inside the structure to damp the resonances associated with the box. The conductivities of the layers are 0.0227 S/cm and 0.01135 S/cm, respectively. Similar lossy material layers are added in the simulation of the composite box with slots, shown in Figure 9.

Figure 10 demonstrates the comparison of far electric field from the source without any box, with PEC enclosure, and with the composite box. The dependencies of S.E. as functions of frequency for the PEC box with slots and for the composite box are shown in Figure 11. It is seen that the S.E. of the composite box with slots is higher than that of the PEC box, particularly at higher frequencies, where the radiation from the slots becomes substantial.

### 5. MULTILAYER ENCLOSURES

The shielding performance can be improved by stacking two different types of carbon-fiber composites: absorbing layers with low concentration of the carbon fibers, i.e., below the percolation threshold; and reflecting layers with concentration of the carbon fibers increased up to the percolation threshold or above it, so that the conductivity of this layer dramatically increases. Mc Lachlan’s formula (2) can be used to calculate the effective parameters of a composite. The

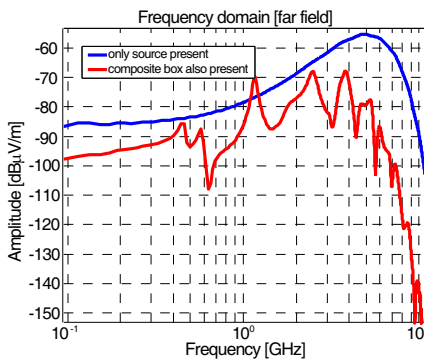

**Figure 7.** Electric field in the far-field region.

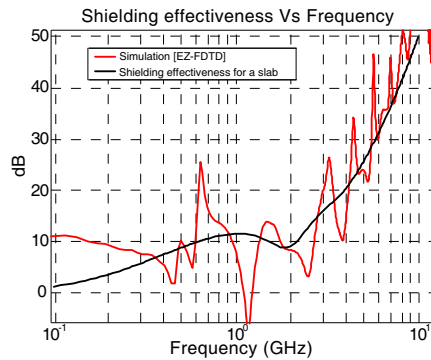

**Figure 8.** Shielding effectiveness of the composite box (EZ-FDTD modeled) and an infinite 2D slab of the same thickness (10 mm) in plane-wave formulation.

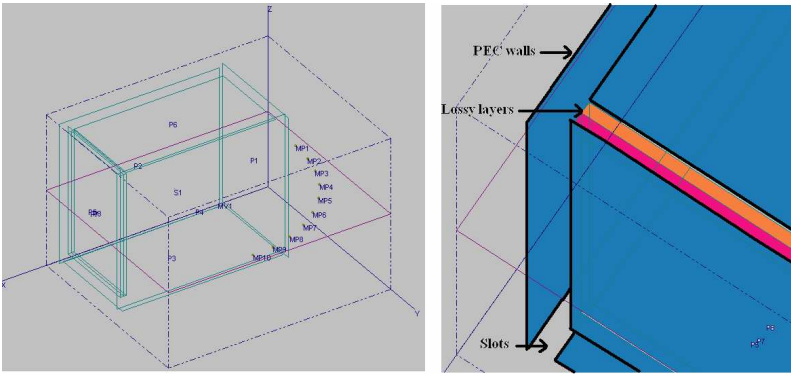

**Figure 9.** PEC box with slots and two conductive layers to damp box resonances.

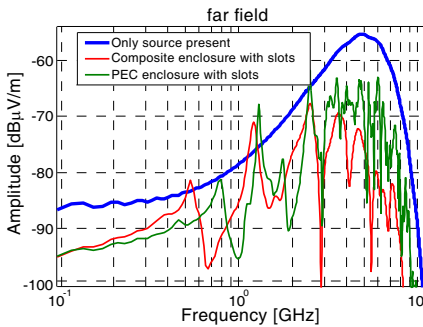

**Figure 10.** Comparison of the electric field  $E$  (dBμV/m) in the far-field region for the source without enclosure, with the composite enclosure with slots, and with the PEC box with slots.

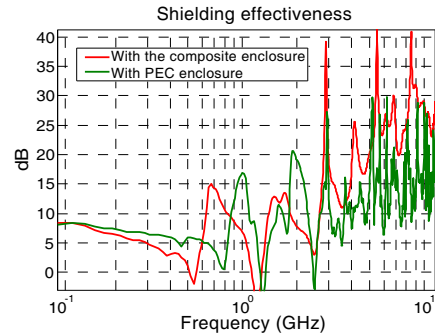

**Figure 11.** Comparison of the S.E. for the composite enclosure and PEC enclosure with slots.

effective permittivity of the composite material for the concentration of carbon fibers above the percolation threshold is very sensitive to the process exponents and the percolation threshold. The parameters of the carbon fibers taken for calculating the permittivity of the conducting composite are the following: the conductivity of fibers is  $\sigma_c = 10^4$  S/m; the aspect ratio is  $a = 100$ ; the percolation threshold is assumed as  $1/a = 1\%$ , volume fraction of inclusions is taken 1.2% in these computations. The process exponents, for simplicity, were chosen equal to  $s = t = 1$ . Then Equation (2) would actually coincide

with the symmetrical Bruggeman model [38], with the percolation threshold  $p_c$  introduced as a parameter. Figures 12(a) and (b) show the permittivity properties of the conducting composite, calculated using (2), and then curve-fitted with Debye parameters using the GA. Table 2 contains possible sets of parameters of fibers for a conducting layer with permittivity curves shown in Figure 12. These sets have been obtained using the GA optimization. If a single slab of such composite material is used, it suffers from the disadvantage of radiating from the slots and apertures [9]. To achieve wideband shielding, this conducting (=reflecting) composite material can be stacked with the non-conducting (=absorbing) composite material discussed above, as shown in Figure 13. Table 3 represents the properties of fibers in the stack of the 12-mm-thick absorbing composite layer and the 3-mm-thick reflecting composite layer. Figure 14 shows the shielding effectiveness predicted with this stack in the plane-wave formulation, and Figure 15 represents the S.E. calculated in EZ-FDTD for a composite box with slots and the corresponding PEC box with slots.

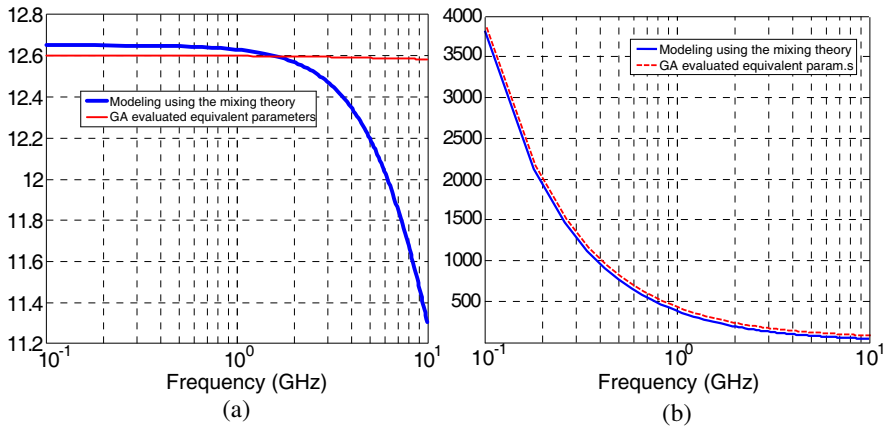

**Figure 12.** Effective permittivity of conducting composite layer: (a) real part and (b) imaginary part.

**Table 2.** Properties of fibers for a conducting layer.

Index	Conductivity [S/m]	Aspect ratio	Percolation Threshold (1/aspect_ratio), % vol.	Concentration (should be greater than percolation threshold), % vol.
Set 1	60000	600	> 0.16	0.2
Set 2	40000	400	> 0.25	0.3
Set 3	10000	100	> 1.0	1.2

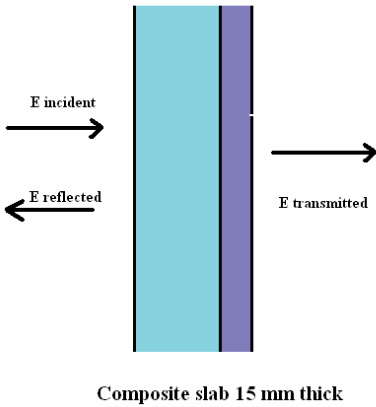

**Figure 13.** Stack of two composite layers: 12-mm absorbing layer (left) and 3-mm reflecting (right).

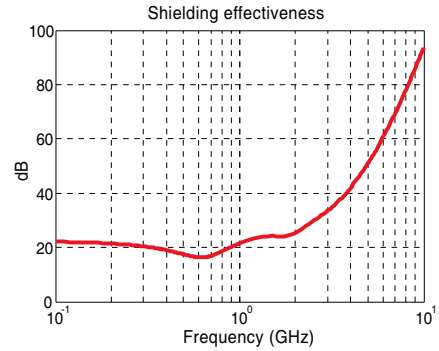

**Figure 14.** Shielding effectiveness due to two composite layers: 12-mm absorbing layer (left) and 3-mm reflecting (right).

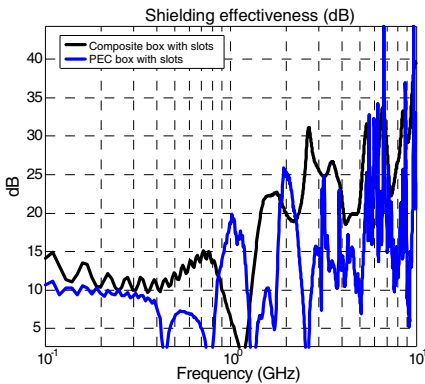

**Figure 15.** EZ-FDTD modeled shielding effectiveness in the PEC and multilayer (12-mm absorbing layer + 3-mm reflecting layer) composite boxes with slots.

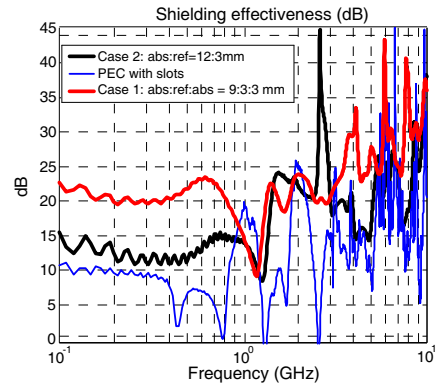

**Figure 16.** EZ-FDTD modeled shielding effectiveness in the PEC and two different multilayer structures.

**Table 3.** Properties of fibers for layers in the stack.

Carbon fiber composite material properties [layer 1]		Carbon fiber composite material properties [layer 2]	
Fiber conductivity	69998 S/m	Fiber conductivity	10000 S/m
Fiber shape	Cylindrical	Fiber shape	Cylindrical
Fiber vol. fraction concentration	0.07%	Fiber vol. fraction concentration	1.2%
Aspect ratio (length/diameter)	800	Aspect ratio (length/diameter)	100
Percolation threshold	0.13%	Percolation threshold	1%
Base material	Teflon	Base material	Teflon
Thickness	12 mm	Thickness	3 mm

The shielding effect at low frequencies (1–2 GHz) is due to the reflection by the conductive layer, and above 2 GHz is due to the absorption. It is seen that the composite box with slots provides the overall better shielding effectiveness than the PEC box with slots.

The results of EZ-FDTD modeling of a PEC enclosure with slots and multilayered (absorbing-reflecting-absorbing) composite structure with slots have been also obtained, and they are shown in Figure 16. Thicknesses of the absorbing layers were 9 mm and 3 mm, and of the reflecting layer it was 3 mm. The other parameters were as summarized in Table 3. The substantial increase in shielding effectiveness is achieved with this multilayer structure compared to the PEC box with slots and to the multilayer composite structure shown in Figure 15.

## 6. CONCLUSION

Polymer-based carbon-filled composites can be used for wideband microwave shielding structures. The effective electromagnetic parameters of these composites can be estimated using Maxwell-Garnett formulation for concentrations of inclusions below percolation threshold, and using McLachlan's theory, when concentration of inclusions is close or slightly above the percolation threshold. Effective complex permittivity of a carbon-filled composite depends on the properties of the fibers, such as their aspect ratio, concentration, conductivity, and rate of alignment. The contents of composites with randomly oriented carbon fibers can be optimized from the point of view of achieving the highest average electromagnetic shielding effectiveness over the frequency range of interest. In this work, a genetic algorithm optimization procedure has been applied. The

frequency dependence of the effective permittivity of the resultant optimized composite is curve-fitted using parameters of the Debye frequency dispersion law. Then the shielding effectiveness performance of the structures made of the proposed composite material can be evaluated using a full-wave numerical simulation tool, which can accept the extracted Debye parameters of the composite dielectric. In particular, the EZ-FDTD full-wave simulation tool developed by EMC Laboratory of MS&T and IBM can be applied to evaluate shielding effectiveness of composite structures with Debye frequency characteristics. The modeling results show that composite materials can be used for shielding enclosures with slots more effectively than metal (PEC) enclosures. Stacking layers of absorbing composite materials and reflecting composite materials allows for increasing shielding effectiveness in a wider frequency range.

## REFERENCES

1. Norman, R. H., *Electrically Conducting Rubber Composites*, Elsevier, Oxford, 1970.
2. Wang, Y. and X. Jing, "Intrinsically conducting polymers for electromagnetic interference shielding," *Polymers for Advanced Technologies*, Vol. 16, 344–351, 2005.
3. Faez, R., R. H. Schuster, and M. A. De Paoli, "A conductive elastomer based on EPDM and polyaniline 2. Effect of the crosslinking method," *European Polymer Journal*, Vol. 38, 2459–2463, 2002.
4. Fox, R. T., V. Wani, K. E. Howard, A. Bogle, and L. Kempel, "Conductive polymer composite materials and their utility in electromagnetic shielding applications," *Journal of Applied Polymer Science*, Vol. 107, No. 4, 2558–2566, 2008.
5. Mather, P. J. and K. M. Thomas, "Carbon black/high density polyethylene conducting composite materials," *Journal of Material Science*, Vol. 32, 401–407, 1997.
6. Radford, D. W., "Metallized microballoon filled composite EMI shielding materials," *Journal of Testing and Evaluation (JTE)*, Vol. 21, No. 5, 396–401, 1993.
7. Rea, S. P., D. Wylie, D. Linton, E. Orr, and J. McConnell, "EMI shielding of woven carbon fibre composites," *IEEE High Frequency Postgraduate Student Colloquium*, 205–210, UMIST, Manchester, UK, Sep. 6–7, 2004.
8. Ding, J., S. P. Rea, E. Orr, and J. McConnell, "Mixture properties of carbon fibre composite materials for electronics shielding in



- systems packaging,” *Electronics System-Integration Technology Conference, 2006. 1st*, 19–25, Sep. 5–7, 2006.
9. Li, M., J. Neubel, J. L. Drewniak, R. E. DuBroff, T. H. Hubing, and T. P. Van Doren, “EMI from airflow aperture arrays in shielding enclosures — Experiments, FDTD and MOM modeling,” *IEEE Transactions on Electromagnetic Compatibility*, Vol. 42, No. 3, 265–275, Aug. 2000.
  10. Koledintseva, M. Y., P. C. Ravva, R. E. DuBroff, J. L. Drewniak, K. N. Rozanov, and B. Archambeault, “Engineering of composite media for shields at microwave frequencies,” *Proc. IEEE Int. Symp. Electromag. Compat.*, Vol. 1, 169–174, Chicago, IL, Aug. 2005.
  11. Koledintseva, M. Y., P. C. Ravva, J. L. Drewniak, A. A. Kitaitsev, and A. A. Shinkov, “Engineering of ferrite-graphite media for microwave shields,” *Proc. Int. IEEE Symp. Electromag. Compat.*, 598–602, Portland, OR, Aug. 2006.
  12. Koledintseva, M. Y., R. E. DuBroff, R. W. Schwartz, and J. L. Drewniak, “Double statistical distribution of conductivity and aspect ratio of inclusions in dielectric mixtures at microwave frequencies,” *Progress In Electromagnetics Research*, PIER 77, 193–214, 2007.
  13. De Rosa, I. M., F. Sarasini, M. S. Sarto, and A. Tamburrano, “EMC impact of advanced carbon fiber/carbon nanotube reinforced composites for next-generation aerospace applications,” *IEEE Transactions on Electromagnetic Compatibility*, Vol. 50, No. 3, Part 1, 556–563, 2008.
  14. Yang, Y., M. C. Gupta, K. L. Dudley, and R. W. Lawrence, “A comparative study of EMI shielding properties of carbon nanofiber and multi-walled carbon nanotube filled polymer composites,” *Journal of Nanoscience and Nanotechnology*, Vol. 5, 927–931, 2005.
  15. Li, Y., C. Chen, S. Zhang, Y. Ni, and J. Huang, “Electrical conductivity and electromagnetic interference shielding characteristics of multiwalled carbon nanotube filled polyacrylate composite films,” *Applied Surface Science*, Vol. 254, No. 18, 5766–5771, Jul. 2008.
  16. Liu, L., S. Matitsine, Y. B. Gan, L. F. Chen, L. B. Kong, and K. N. Rozanov, “Frequency dependence of effective permittivity of carbon nanotube composites,” *J. Appl. Phys.*, Vol. 101, 094106, 2007.
  17. Matitsine, S. M., K. M. Hock, L. Liu, Y. B. Gan, A. N. Lagarkov, and K. N. Rozanov, “Shift of resonance frequency of long

- conducting fibers embedded in a composite,” *J. Appl. Phys.*, Vol. 94, No. 2, 1146–1154, Jul. 15, 2003.
18. Sihvola, A. and J. A. Kong, “Effective permittivity of dielectric mixtures,” *IEEE Trans. Geosc. Remote Sens.*, Vol. 26, No. 4, 420–429, 1988.
  19. Neelakanta, P. S., *Handbook of Electromagnetic Materials*, Boca Raton, CRC Press, FL, 1995.
  20. Kuester, E. F. and C. L. Holloway, “Comparison of approximations for effective parameters of artificial dielectrics,” *IEEE Trans. Microw. Theory Techn.*, Vol. 3, 1752–1755, 1990.
  21. Sheng, P., “Theory of dielectric function of granular composite media,” *Phys. Rev. Letters*, Vol. 45, No. 1, 60–63, 1980.
  22. Doyle, W. T. and I. S. Jacobs, “The influence of particle shape on dielectric enhancement in metal-insulator composites,” *J. Appl. Phys.*, Vol. 71, No. 8, 3926–3936, 1992.
  23. Diaz, R. E., W. M. Merrill, and N. G. Alexopoulos, “Analytical framework for the modeling of effective media,” *J. Appl. Phys.*, Vol. 84, No. 12, 8615–8626, 1998.
  24. Maxwell, Garnett, J. C., “Colors in metal glasses and metal films,” *Philos. Trans. Royal Soc. London, Sect. A*, Vol. 3, 385–420, 1904.
  25. Koledintseva, M. Y., J. Wu, J. Zhang, J. L. Drewniak, and K. N. Rozanov, “Representation of permittivity for multi-phase dielectric mixtures in FDTD modeling,” *Proc. IEEE Symp. Electromag. Compat.*, Vol. 1, 309–314, Santa Clara, CA, Aug. 9–13, 2004.
  26. McLachlan, D. S., A. Priou, I. Chernie, E. Isaac, and E. Henry, “Modeling the permittivity of composite materials with general effective medium equation,” *Journal of Electromagnetic Waves and Applications*, Vol. 6, No. 6, 1099–1131, 1992.
  27. Koledintseva, M. Y., G. Antonini, J. Zhang, A. Orlandi, K. N. Rozanov, and J. L. Drewniak, “Reconstruction of the parameters of Debye and Lorentzian dispersive media using a Genetic Algorithm,” *Proc. IEEE Int. Symp. Electromag. Compat.*, Vol. 2, 898–903, Boston, MA, Aug. 18–22, 2003.
  28. Orfanidis, S. J., *Electromagnetic Waves and Antennas*, Chap. 5, online Rutgers University, Multilayer Structures, Nov. 2004.
  29. Koledintseva, M. Y., V. V. Bodrov, I. V. Sourkova, M. M. Sabirov, and V. I. Sourkov, “Unified spectral technique application for study of radiator behavior near planar layered composites,” *Progress In Electromagnetics Research*, PIER 66, 317–357, 2006.
  30. Koledintseva, M. Y., R. E. DuBroff, and R. W. Schwartz, “A

- Maxwell Garnett model for dielectric mixtures containing conducting particles at optical frequencies,” *Progress In Electromagnetics Research*, PIER 63, 223–242, 2006.
31. Koledintseva, M. Y., S. K. R. Chandra, R. E. DuBroff, and R. W. Schwartz, “Modeling of dielectric mixtures containing conducting inclusions with statistically distributed aspect ratio,” *Progress In Electromagnetics Research*, PIER 66, 213–228, 2006
  32. Youngs, I. J., “Exploring the universal nature of electrical percolation exponents by genetic algorithm fitting with general effective medium theory,” *J. Phys, D: Appl. Phys.*, Vol. 35, 3127–3137, 2002.
  33. Lagarkov, A. N. and A. K. Sarychev, “Electromagnetic properties of composites containing elongated conducting inclusions,” *Physical Review B*, Vol. 53, No. 10, 6318–6336, Mar. 1996.
  34. Obukhov, S. P., “Percolation in system of randomly distributed sticks,” *J. Physics, A: Math. Gen.*, Vol. 21, 3975–3978, 1988.
  35. Lagarkov, A. N., S. M. Matytsin, K. N. Rozanov, and A. K. Sarychev, “Dielectric properties of fiber filled composites,” *J. Appl. Phys.*, Vol. 84, No. 7, 3806–3814, Oct. 1998.
  36. *Teflon Dielectric Properties*, [http://www.dupont.com/Teflon\\_Industrial/en\\_US/products/product\\_by\\_name/teflon.](http://www.dupont.com/Teflon_Industrial/en_US/products/product_by_name/teflon.), Nov. 2005.
  37. Koledintseva, M., J. Drewniak, Y. J. Zhang, J. Lenn, and M. Thoms, “Modeling of ferrite-based materials for shielding enclosures,” *J. Magn. Magn. Mater. (JMMM)*, Vol. 321, 730–733, 2009.
  38. Sihvola, A., *Electromagnetic Mixing Formulas and Applications*, IEE Electromagnetic Waves Series 47, The IEE, UK, 1999.