

UC Berkeley

Research Reports

Title

Modeling The Santa Monica Freeway Corridor: A Feasibility Study

Permalink

<https://escholarship.org/uc/item/7581k7rr>

Authors

Skabardonis, Alexander

Dahlgren, Joy

May, Adolf D.

Publication Date

1998-12-01

This paper has been mechanically scanned. Some errors may have been inadvertently introduced.

CALIFORNIA PATH PROGRAM
INSTITUTE OF TRANSPORTATION STUDIES
UNIVERSITY OF CALIFORNIA, BERKELEY

Modeling the Santa Monica Freeway Corridor: A Feasibility Study

Alexander Skabardonis

Joy Dahlgren

Adolf D. May

California PATH Research Report

UCB-ITS-PRR-98-37

This work was performed as part of the California PATH Program of the University of California, in cooperation with the State of California Business, Transportation, and Housing Agency, Department of Transportation; and the United States Department of Transportation, Federal Highway Administration.

The contents of this report reflect the views of the authors who are responsible for the facts and the accuracy of the data presented herein. The contents do not necessarily reflect the official views or policies of the State of California. This report does not constitute a standard, specification, or regulation.

Report for MOU 270

December 1998

ISSN 1055-1425

ACKNOWLEDGMENTS

This study was performed **as** part of the California's PATH (Partners for Advanced Highways and Transit) Program (**MOU-270**) at the Institute of Transportation Studies (ITS) University of California Berkeley.

We appreciate the assistance and cooperation of Pat Conroy, Joe Palen and Larry Jellison of the Division of New Technology, Caltrans Headquarters. Hector Obezo, Jack Smith, Doug Murphy and Chiao Wei of the Los Angeles Caltrans District 7, and Brian Gallagher of the Los Angeles DOT provided **valuable** input to the study. We wish **to** thank the model developers, and researchers and practitioners for providing information to the various models throughout the study.

Modeling the Santa Monica Freeway Corridor: A Feasibility Study

A. Skabardonis, J. Dahgren, A.D. May

June 1998

ABSTRACT

The report describes the **findings** of a feasibility study to develop a simulation testbed for the Santa Monica freeway corridor. **An** evaluation of the state-of-the-art models for **ATMIS** applications on freeway corridors was performed. Information was obtained from a comprehensive literature review, and contacts with model developers and users. The evaluation was based on the model capabilities, input data requirements and output options. Particular attention was placed on the record of real-life calibration, validation and practical application of the models. The findings indicate that the **CORSIM** and **INTEGRATION** models have the higher probability of successful application in real-world applications.

The proper application of the selected simulation models requires a comprehensive database. The assessment of the data requirements and availability undertaken for the Santa Monica freeway corridor indicates that a substantial amount of information **is** already available. However, most of the traffic demand data need to be collected. *Also*, traffic performance data need to be collected for comparisons of field conditions and model predictions

Keywords:

Freeways, Simulation Models, Traffic Flow

EXECUTIVE SUMMARY

Objectives and Methodology

Advanced traffic management and traffic information systems (ATMIS) offer significant potential for reducing traffic congestion and systematically improving the operation of freeway corridors. **ATMS** include freeway surveillance and incident management systems, ramp metering, and adaptive traffic signal control systems. **ATIS** technologies provide travelers with navigational information and routing advice based on real-time information. Traffic simulation models could provide both offline evaluation of alternative concepts and approaches, **as well as** online operation of proposed systems.

The objectives of this study were to evaluate existing simulation tools for freeway corridors and their capabilities in modeling **ATMIS** strategies. For the purposes of this study, freeway corridors are defined **as** consisting of freeway Sections of about **16 km (10 mi)** in length, and adjoining surface street networks with more than 150 signalized intersections. **A** feasibility analysis was undertaken to develop a simulation testbed for the Santa Monica freeway corridor in Los Angeles.

An evaluation of the state-of-the-art simulation models for on freeway corridors was performed. Information was obtained from a comprehensive literature review, and contacts with model developers and users. The evaluation was based on the model capabilities, input data requirements and output options. Particular attention was placed on the record of real-life calibration, validation and practical application of the models. The data needs and availability for developing a simulation testbed for the Santa Monica freeway corridor was **assessed** through review of existing information, and field visits.

Findings

There is a limited number of models that can be applied to freeway corridors. Ten candidate models were identified **as** potential simulation tools. **Of** these models only about one-half of them are operational, available to the user community, and have a record of practical application. None of the models is capable of explicitly simulating **all** of the proposed the **ATMIS** scenarios. The applications to-date of the leading simulation models on real-life corridors are very limited, and not fully documented to understand problems encountered and suggestions for their resolution.

The **CORSIM** and **INTEGRATION** models appear **as** the most suitable tools for near-term freeway corridor applications. Both models have continued development support with ongoing enhancements, and more applications by the user community. The assessment of the data requirements and availability undertaken for the Santa Monica freeway corridor indicates that a substantial amount of data is already available, but most of the traffic demand data need to be collected. The effort required to collect the data for simulating the study area using **CORSIM** or **INTEGRATION** is estimated at one person-year.

Recommendations

It is recommended to apply both the **CORSIM** and **INTEGRATION** models to a selected portion of the Santa Monica freeway corridor in Los Angeles for a single peak period. **This** real-life application **will** provide insights on the model capabilities in simulating the study area, and refine the data collection tasks based on the actual models usage, before undertaking a full scale simulation testbed development.

TABLE OF CONTENTS

Acknowledgments	ii
Abstract	iii
Executive Summary	iv
Table of Contents	v
List of Tables	vi
CHAPTER 1. INTRODUCTION	1
1.1 Problem Statement	1
1.2 Objectives of the Study	1
1.3 Organization of the Report	2
CHAPTER 2. SIMULATION MODELS: STATE-OF-THE-ART	3
2.1 Requirements for ATMIS Modeling	3
2.2 Modeling Approaches	3
2.3 Literature Review	4
2.4 Description of Selected Models	6
CHAPTER 3. EVALUATION OF THE MODELS	11
3.1 Preliminary Evaluation	11
3.1.1 Evaluation Criteria	11
3.1.2 Findings	12
3.2 Detailed Models Evaluation	12
3.2.1 Input Data Requirements	12
3.2.2 Input Data <i>Coding</i>	15
3.2.3 Model Outputs	15
3.2.4 Computational Aspects	16
3.2.5 Lessons Learned from Applications Experiences	16
3.2.6 Findings	16

CHAPTER 4. DATA ASSESSMENT	19
4.1 Data from Previous Simulation Studies	19
4.2 Data Requirements and Availability	19
4.3 Workplan for Database Development	20
CHAPTER 5. CONCLUSIONS	21
5.1 <i>Summary</i> of the Study Findings	21
5.2 Discussion	22
REFERENCES	R-1
APPENDIX A. BIBLIOGRAPHY ON SIMULATION MODELS	A-1
APPENDIX B. LIST OF CONTACTS	B-1
APPENDIX C. EXPERIENCES WITH SIMULATION MODELS	C-1
APPENDIX D. DATA FOR TRANSPORTATION MODELING IN THE SANTA MONICA CORRIDOR	D-1

LIST OF TABLES

Table 1. Simulation Models for Freeway Corridors	5
Table 2. Input Data Required for the Application of Selected Models: Freeways	13
Table 3. Input Data Required for the Application of Selected Models: Surface Streets	14
Table 4. Selected Freeway Simulation Models: Real-Life Application Experiences	17

CHAPTER 1

INTRODUCTION

1.1 Problem Statement

Advanced traffic management and traffic information systems (ATMIS) offer significant potential for reducing traffic congestion and systematically improving the operation of the existing transportation networks. ATMS include urban traffic control systems, freeway surveillance and incident management systems, ramp metering, and **High** Occupancy Vehicles (HOV) priority treatment. ATIS technologies are designed to provide the traveler with navigational information and routing advice based on **real-time traffic** data.

The effects of these technologies on traffic performance must be carefully evaluated. Several field operational tests (FOTs) have been completed or are currently underway to measure the ATMIS benefits and costs in a real-world environment and are clearly of vital importance for system design and evaluation. However, such field trials are limited in terms of the number of **scenarios** than *can* tested and in terms of the range of conditions for which their performance *can* be examined. Traffic simulation models are particularly valuable in this respect **as** a complementary aid to system design for identifying key operation and performance issues, and for testing alternatives under a range of operating conditions.

Previous experiences with simulation models in large real-life freeway corridors have been limited and produced mixed results. For the purposes of this report, freeway corridors are defined **as** consisting of freeway **sections** of about 16 Km (10 **m**) in length, and adjoining surface street networks with more than **150** signalized intersections. Major problems reported with the models' applications included:

- a) the accuracy of the models in representing traffic flow,
- b) lack of features pertinent to ATMIS applications (e.g., real-time control),
- c) the amount and type of required input data,
- d) effort and data required for calibration and validation,
- e) computer run times

1.2 Objectives of the Study

The objective of the study described in this report was to provide recommendations and guidance whether the current state-of-the-art simulation models, and the input data that are commonly available, **can** support near-term successful ATMIS applications on freeway corridors. The study investigated the feasibility of developing a simulation testbed for a section of the 1-10 freeway and the surrounding surface ~~street~~ network in Los Angeles ("the **Smart** Corridor".)

The **Smart** Corridor is a joint demonstration project between Caltrans, LA DOT, CHP, LAPD, LAMTA, and SCRTD. The objectives are to improve traffic flow in the corridor through implementation of ATMIS concepts including ramp metering, signal timing optimization, motorist

information systems and incident management systems. Advanced software and hardware is being implemented to allow the deployment of such strategies by the partner agencies in an integrated and coordinated fashion. The Smart Corridor includes a 10 mile section of the Santa Monica freeway (from the I-405 to the SR110) and a surface street network with five major parallel arterials and over 300 signalized intersections. The freeway section is instrumented with loop detectors that provide real time data to the Caltrans District 7 TMC. Traffic signals are controlled by the City of Los Angeles' ATISAC system as coordinated, grouped in several subsystems.

Work in off-line evaluation of selected ATIS strategies in the **Smart** Corridor through simulation begun at ITS Berkeley since 1989 under the direction of Professor Adolf May, first by using the FREQ/TRANSYT simulation models and later the INTEGRATION model. The work **has** provided valuable insights on the likely benefits of selected strategies, the data collection requirements for large scale simulations, and the capabilities and simulation **of** existing modeling tools. However, a detailed calibrated simulation testbed for the Smart corridor has not been completed largely because of both data and modeling limitations. Thus, there **is** still a need for a realistic simulation testbed for the study area.

1.3 Organization of the Report

Chapter 2 of the report discusses key requirements for modeling **ATIS** scenarios, discusses existing simulation modeling approaches, and describes the simulation models identified through literature search. Chapter 3 describes the process of and the findings from the evaluation of the selected models. Chapter 4 presents the findings from the assessment of the data available in the study area. Chapter 5 summarizes the study findings and recommendations.

Appendix A includes a bibliography on simulation models for freeway corridors, and Appendix **B** lists model developers. Appendix C includes an internal project report on the models' evaluation. Appendix D documents in detail the assessment of the data in the Santa Monica freeway corridor.

CECAPTER 2

SIMULATION MODELS: STATE-OF-THE-ART

2.1 Requirements for ATMIS Modeling

The analysis and evaluation of ATMIS strategies requires comprehensive analysis tools, which could provide both offline evaluation of alternative concepts and approaches, as well as online (real-time) operation of proposed systems. Some key requirements for simulation models in order to be applicable for modeling fi-eway corridors include the following:

- **Network configuration:** simulate highway facilities consisting both of fi-eways and surface street networks, often encompassing a large number of road segments (~~links~~) and intersections (nodes). Explicit modeling of design, traffic, and control characteristics commonly occurring in the field.
- **Modeling of traffic flow:** simulate the variability of traffic conditions in time and space, and the associated growth and decay of congestion. Simulate incidents (occurrence, severity, response, recovery), as well as the driver's response to incidents.
- **Traffic control and management:** modeling of various control modes on both fi-eways and surface streets (pretimed, traffic responsive, adaptive), surveillance systems, incident detection, changeable message signs, and communications infrastructure.
- **ATIS modeling:** simulate different types of information systems. Route vehicles to their destination based on their current locations in the network and access to information on time-varying traffic conditions. Modeling of the driver's responses to ATIS strategies.
- **Optimization:** ability to optimize designs and control schemes and simulate their performance.

2.2 Modeling Approaches

Traffic simulation models have been developed since the introduction of digital computers in the 50's. The efforts focused on models to evaluate alternative designs and control scenarios for specific facilities. Later, emphasis was placed on models that could also optimize the traffic performance (e.g., determining optimal signal timing plans). The models were facility specific (such as isolated intersections, arterials and fi-eway segments), and have been classified as either macroscopic or microscopic. Macroscopic models consider the average traffic stream characteristics (flow, speed, density) or platoons of vehicles, and incorporate analytical relationships to model traffic flow. Microscopic models in contrast consider the characteristics, movements and interactions of individual vehicles.

Simulation models of freeway corridors **has** so far been limited because of the intensive data and computational requirements for Simulating traffic flow in large networks. Recently, the need to **assess** ATMS systems coupled with dramatic increases in computer processing speed prompted the development of freeway corridor models. A number of these models were designed **as mesoscopic**, simulating individual vehicles based on macroscopic flow relationships, and included dynamic traffic assignment (DTA) capabilities.

Existing freeway corridor models also *can* be distinguished as **integrated** or "**interfaced**" **as** it relates to the interaction of modeling of traffic flow with DTA algorithms and traffic control strategies. Integrated models provide **a** more efficient structure from the point of view of network coding and computer run times, but generally cannot evaluate alternative traffic assignment models or traffic control algorithms other than the embedded algorithms in the model. On the other hand, simulators that *can* be interfaced with control and assignment algorithms **can** serve **as** testbeds for evaluating alternative algorithms. **This** formulation requires the availability of proper linkages for the interface between the models.

2.3 Literature Review

An extensive literature search was undertaken using the UC Berkeley information retrieval systems, the TRB TRIS database and the World Wide Web on the internet. Over **70** simulation models were identified. **Most** of these models deal with specific **aspects** of traffic flow or assessment of control strategies (e.g., light rail preemption at traffic **signals**, or signal control at isolated intersections). Ten simulation models appear to be applicable for modeling freeway corridors **as** defined in this study and selected for further investigation (Table 1). The selection process was based on the key requirements listed in Section **2.1**.

Next, the developers of the models listed in Table 1 were contacted to a) obtain additional information about the model, b) obtain input on proposed criteria for the models' evaluation, c) suggest any other models for inclusion in the list of selected models, d) provide information on the models' application and names of model users.

Following the responses from the model developers, supplementary literature searches were performed and a reference list on the development and application of the selected models since **1987** was compiled, and is included in Appendix A. The reference list includes over 300 publications and it is organized by individual model, and the citations for each model are listed in chronological order. References related to the CORFLO and CORSIM models account for more than half of the total citations. Ninety-three references **pertain** to the NETSIM model (component of CORSIM).

TABLE 1. SIMULATION MODELS FOR FREEWAY CORRIDORS

#	MODEL	DEVELOPER	YEAR	TYPE/FUNCTION					
				Micro	Macro	Meso	Simulation	Optimization	Assignment
1	CONTRAM	TRL	1978		X		X		X
2	CORFLO	FHWA	1991 (1980)		X		X		x1
3	CORSIM	FHWA	1994 (1978)	X			X		X2
4	DYNASMART	U Texas/UCI	1988			X	X		X
5	INTEGRATION	Queens U, CA	1985	X			X	x3	X
6	METACOR	U Munich	1990		X		X	x4	X
7	PARAMICS	Quadstone, UK	1992	X			X		X
8	SATURN	U Leeds, UK	1979		X		X		X
9	TRANSIMS	LANL, FHWA	1995	X			X		X
10	WATSIM	KLD Assoc	1994	X			X		x5

NOTES:

YEAR: year information about model was reported, (XXX): year component model(s) available

X1: Interface with static assignment model

X2: Interface with dynamic assignment model (under development)

X3: optimization of isolated signals

X4: optimal ramp metering rates

X5: Interface with dynamic assignment models

24 Description of the Selected Models

The selected models are briefly described in the following sections. Key references by model are provided in the reference section of the report.

CONTRAM

CONTRAM is a macroscopic simulation and assignment model developed at the British Transport Research Laboratory (TRL) to evaluate traffic management schemes for urban networks. The model considers queuing in the assignment and performs iterative multiple time-period assignment. **Link** travel times are updated based on macroscopic simulation of traffic flow.

A number of extensions have been implemented in the basic CONTRAM model to simulate ATMIS strategies. RGCONTRAM from the University of Southampton was developed to evaluate in-vehicle route guidance systems. TRL's MOLA simulates variable message signs and incidents. A ramp metering algorithm is under testing in the Netherlands. *Also*, an interface with the TRANSYT model permits optimization of signal settings.

The model is well documented and its standard version is commercially available. Model extensions and interfaces *can* be obtained by special arrangement with TRL. The applications of the model in the **US** are limited. It **has** been **used** by UC Irvine in the city of Anaheim only **as** an assignment tool, and by UC Berkeley in exploratory simulations of the Los Angeles Santa Monica freeway. Problems encountered were mostly on the accuracy of simulation on freeways.

The CORFLO model

The CORFLO model developed for the FHWA consists of the **FREFLO** model for freeways and the NETFLO1 and NETFLO2 models for surface streets. The interface of adjoining subnetworks is accomplished by defining interface nodes, which represent points at which vehicles leave one subnetwork and enter another. Associated with each subnetwork is a vehicle holding area where exiting vehicles are held until the next subnetwork *can* receive them. Traffic may be assigned to the different subnetworks using the **TRAFFIC** assignment model (a static equilibrium assignment algorithm.)

FREFLO is a macroscopic model based on the conservation equation and a dynamic speed-density equation. FREFLO was originally developed by Payne. The model *can* handle different vehicle classes (busses, carpools), **HOV** facilities, and incidents on the freeway, but it cannot model ramp operations.

NETFLO1 is a microscopic event scanning simulator (a simplification of the NETSIM model). **NETFLO2** models traffic using flow profiles similar to the TRANSYT model. Unlike TRANSYT, however, it *can* simulate signals with different cycle lengths and queue **spillovers**.

CORFLO has been designed to evaluate design and control strategies on freeways and surface streets, **as well as** impacts of incidents and traffic diversion policies. Most of the reported applications involved the use of **FREFLO** model for evaluating freeway operations. There is little information published on the development and application of the **NETFLO** models.

The **CORSIM** model

CORSIM is a microscopic stochastic simulation model consisting of the widely used FRESIM model for freeways and the NETSIM model for the adjoining surface streets. Similar to CORFLO, the interface of the freeway and surface streets subnetworks is handled through interface nodes. Individual vehicles are simulated on the freeway and the ramps based on car-following, lane changing and queue discharge algorithms. Individual driver/vehicle characteristics are randomly assigned based on distributions of driver behavior and vehicle characteristics. CORSIM, probably by far **has** the most sophisticated algorithms for car-following and lane-changing to model in detail traffic operations, oversaturated conditions and incidents.

CORSIM can model pretimed and actuated signal controllers (isolated or coordinated) and local fixed-time or responsive ramp metering. Several types of surveillance systems **can** be simulated. Integrated ramp metering control is under development.

The current version of CORSIM has very limited capabilities for modeling ATIS strategies. **An** enhanced model version with interfaces with various traffic assignment and control algorithms is currently under development. **This** modeling system is called TrEPGS (Traffic Estimation, Prediction, and Guidance System) and is specifically designed for ATMIS applications. A prototype version of the software was demonstrated at the 1998 ITS America Annual Meeting, and it is currently being evaluated by the Oakridge National Laboratory.

The **DYNASMART** model

The DYNASMART (**Dynamic** Network Assignment Simulation Model for Advanced Road Telematics) was designed **as** both an assignment and simulation model for ATMIS. Traffic flow is simulated macroscopically based on the continuity equation and a modified Greenshields speed-density relationships. The model **can** simulate traffic signals, ramp meters and incidents. The model calculates optimal travel paths based on the simulated travel times, and simulates the movements and routing decisions by individual drivers equipped with in-vehicle information systems (update of information and desire to switch based on thresholds).

DYNASMART is available **as** a research tool, and it **has** been used by the model developers to **assess** the effectiveness of ATIS **scenarios** in a number of networks (Anaheim, Austin, **Irvine**). Further development of the model is underway at the University of Texas at Austin **as** a dynamic traffic assignment and optimization tool (DYNASMART-X).

The **INTEGRATION** model

The INTEGRATION model was originally developed by M Van Aerde in 1985 and it has been under continuous development and refinement since then. The model simulates combined freeway and arterial networks which experience time-varying congestion. It assigns individual vehicles sequentially to a network that is already loaded with any previous departures that have not reached their destination. Up to five different driver/vehicle types are used to represent different routing behavior or various access privileges to real-time traffic conditions.

INTEGRATION originally was designed **as** a mesoscopic model. Individual vehicles were simulated based on macroscopic speed-flow relationships. The latest version of the model is fully microscopic incorporating car-following and lane changing logic. The car-following algorithm is a kinematic model that calculates the individual vehicle speeds based on the macroscopic parameters **of** free-flow speed, **speed** at capacity, capacity and jam density. Calculations are carried out every deci-second. A gap acceptance logic was developed for modeling stop/yield sign control and unprotected left-turns at traffic signals.

Several applications of the model have been reported, mostly by the model developers illustrating the model features and capabilities, including assessment **of** the effectiveness **of** route **guidance** systems, impacts of ramp metering and signal control strategies, and modeling of incidents.

The METACOR/METANET model

METANET is a macroscopic simulation model for freeways. METACOR is an extension of METANET to include modeling of parallel arterials. Both models were developed at the Technical University of Munich in cooperation with **INRETS**, the French Transport Research Laboratory. The simulation **of** traffic flow is based on the flow conservation equation and a dynamic speed-density relationship. METANET **can** model multi-origin, multi-destination freeway networks with arbitrary topology and geometric characteristics (merging, diverging, lane drops, on- and off-ramps).

METANET/METACOR include control and dynamic traffic assignment modules to simulate ramp metering strategies and route information/guidance via changeable message signs. Because of their fast computer execution times **can** be **used** for real-time applications. METANET has been applied by various organizations in Europe **as** part of several EEC sponsored ATMIS research and demonstration projects. METACOR has been applied in a number of sites (Paris, Glasgow) only by the model developers.

The PARAMICS model

PARAMICS is a microscopic simulator originally developed at the Edinburgh Parallel Computing Center in Scotland. The model **has** been designed **as** a fully scalable software operating on UNIX based workstations, and it **uses** parallel processing principles to simulate in real-time very large networks. PARAMICS includes a fully interactive graphical user interface that permits several input data and output displays and animation to be viewed **simultaneously**, **as** well **as** changes in model inputs and parameters **as** the simulation **is** running.

PARAMICS models traffic flow microscopically. Car-following and lane changing formulations are based on driver "aggressiveness" and "awareness" behavioral indicators. The model **can** simulate fixed-time and vehicle actuated signal control, ramp metering, **as** well **as** route information and guidance systems. Applications in UK include modeling of freeway operations, intersection performance analysis and traffic impact studies.

The SATURN model

SATURN was developed at the University of Leeds to evaluate traffic management schemes on local networks. It consists of an equilibrium assignment algorithm and macroscopic flow relationships. It has been widely used to evaluate changes in circulation (one-way streets, pedestrianization schemes) and other traffic management schemes. Regarding **ATMIS** applications, the model **has** been used to evaluate the effectiveness of route guidance systems and road pricing studies.

The macroscopic structure of the model and the equilibrium traffic assignment formulation do not permit realistic modeling of most **ATIS** policies under time-varying traffic conditions. Work is underway by the model developers to replace **SATURN** with a new microscopic model (**DRACULA**) as part of an EEC sponsored project on route **guidance** modeling.

The TRANSIMS model

TRANSIMS is a modeling effort currently underway at the Los Alamos national Laboratory as part of FHWA's travel model improvement program. **TRANSIMS** is intended to provide a regional integrated microsimulation of travel and predict traffic performance and environmental impacts. **TRANSIMS** would forecast travel demand for individual households/travelers instead of aggregate demand estimation through the traditional four-step process (trip generation, distribution, mode choice and assignment) applied at the **zonal** level. The resulting trips would then be microscopically simulated on the road network and performance measures would be predicted including vehicle pollutant emissions and concentrations.

Traffic flow is modeled using the cellular automata approach. The roadway Section is discretized into uniform **sections (cells)** of length equal to the jam distance headway (**25 ft or 7.5 m**), and the vehicle positions among cells are updated each second **using** a constant speed subject to the distance headway.

This approach allows simulation of individual vehicles at a coarse level of detail over very large transportation networks with reasonable computer times. Comparisons with other traffic models indicate that this approach replicates traffic dynamics on a single lane reasonably well.

Currently, **TRANSIMS is still** in a developmental stage and no applications have been reported. There is no field verification of its single lane traffic model and lane changing algorithms. Also, **TRANSIMS** does not support modeling of most of the **ATMIS** strategies.

The WATSim model

WATSim (Wide Area Traffic Simulation) is a microscopic model developed by **KLD Associates**. It is based on the **TRAF-NETSIM** simulation model, extended to simulate traffic operations on freeways and other roadways of any configuration. It incorporates an improved lane-changing and car-following logic to represent stochastic driver behavior, and freeway links with differing capacities associated with different grades, lane widths and horizontal curvature. The freeway model logic **has** been calibrated using the latest data for the 1994 Highway Capacity Manual and field data.

WATSim can be interfaced with **DTA** algorithms to simulate **ATIS** systems. The model automatically creates Origin-Destination (O-D) tables from standard vehicle turn movements on intersections'

approaches, and creates paths for traffic traveling between each **0-D** pair, consistent with **observed** traffic movements. WATSIM accommodates path assignments computed by a DTA model for different vehicle classes. The model produces link travel times and other statistics needed by a DTA model to compute minimum travel time paths for each 0-D pair.

Recent extensions to WATSim include Simulation of light-rail preemption algorithms, toll plaza operations, and **Linkages** with the TRANSYT-7F and PASSER-II **signal** optimization programs to optimize the signal settings along **arterials** and networks.

CHAPTER 3

EVALUATION OF THE MODELS

The evaluation of the selected models consisted of the following steps: first, a set of evaluation criteria were established. Next, the models were evaluated against the criteria and a short list of models was developed. The leading models were then evaluated in detail. **This** evaluation consisted of detailed review of the models' documentation, and information from model users. Recommendations were then formulated on the use of the models.

3.1 Preliminary Evaluation

3.1.1 Evaluation Criteria

The following criteria (**in** order of importance) were established to evaluate the selected models:

1. **Model operational:** the model software and documentation are available and *can* be supplied to model users along with sample input and output files. The model documentation includes sufficient detail to permit understanding of the model principles, input data and coding requirements, and explanation of the model outputs.
2. **Record of application:** the model should have a record of application by users other than the model developers, as well as a record of independently performed calibration/validation.
3. **Network simulation capabilities:** the model should represent the street network at a level of detail for operational analysis. It should explicitly model design characteristics commonly occurring in the field (e.g., merging and weaving areas, various intersection layouts) and produce estimates of performance measures (MOEs) to determine traffic performance and Level of Service (LOS) as per the widely used 1994 Highway Capacity Manual (HCM).
4. **Modeling of traffic flow:** the model should simulate the variability in traffic demand in time and space, and model the growth/interaction and decay of traffic queues, as well as capacity reductions due to incidents and bottlenecks.
5. **Simulation of control strategies:** the model should be able to simulate commonly **used** control strategies for both freeways and arterial streets. These include signal coordination, fixed-time and actuated control, and fixed-time ramp metering. Such control strategies are commonly **used** in practice and for the purposes of this evaluation are not considered **ATMIS** strategies.
6. **Simulation of ATMIS strategies:** the model should handle proposed or being implemented strategies including but not limited to real-time control on surface streets and freeways, surveillance systems, and traveller information systems (changeable message signs and route guidance systems.) **As** it was discussed in Section 2 (Modeling requirements and approaches),

the model may not internally simulate ATMIS **scenarios** but it may interface with control software and DTA algorithms. This modeling approach satisfies the requirements of the last criterion provided that appropriate linkages have been established to allow such interfaces. For example, the simulation model should be able to track individual vehicles and predict the origin-destination travel times for input to traffic assignment algorithms.

3.1.2 Findings

Based on the study of the published materials identified in the literature search and information provided by the model developers, the following five models were found to satisfy the majority of the evaluation criteria listed above and selected for detailed evaluation: **COREFLO**, **CORSIM**, **INTEGRATION**, **PARAMICS** and WATSim.

3.2 Detailed Model Evaluation

The detailed evaluation of the five leading models consisted of in depth review of the models' documentation with emphasis on the model features and capabilities, input data requirements, and output options. Next, model users (other than the model developers) were contacted to discuss their applications experiences.

3.2.1 Input Data Requirements

Table 2 lists the basic field data required for the application of the selected models on freeways and Table 3 for surface streets. The data are grouped into design (supply), demand and control. Supply data consist of the design characteristics for each link (length, number of lanes, type and length of turning lanes, grade, lane usage), free flow speed, saturation flow and lost time at traffic signals. Most of these data are common to most of the models.

Traffic demands for **COREFLO**, **CORSIM** and WATSim models are specified in terms of turning fractions at the network nodes per time **period**, and (optionally) origin-destination data if traffic assignment is executed at the **start** of the simulation. Traffic demands for the **INTEGRATION** and **PARAMICS** are specified in terms of O-D flows per time period.

Traffic control data include specifications of the control **type** (traffic signals/stop signs, ramp meters) **as** well **as** type of traffic signal, phasing, phase length, **offsets**, detector type and location. The data requirements vary with the model features. For example, **CORSIM** and WATSim **can** model in detail actuated controller operations and require data on several control parameters. **INTEGRATION** on the other hand **only** models fixed-time control so inputs include cycle length, and green times.

Additional data may be needed to calibrate the models and to investigate alternative **scenarios**. For example, incident characteristics (location, severity and duration), or surveillance system characteristics (location/type of detectors).

TABLE 2. INPUT DATA REQUIRED FOR THE APPLICATION OF SELECTED MODELS: FREEWAYS

DATA TYPE	MODEL				
	CORFLO	CORSIM	INTEGRATION	PARAMICS	WATSIM
Network Data					
Node coordinates	X (O)	X (O)	X (O)	X (O)	X (O)
Link length (ft)	X	X	X	X	X
Grade		X	N/A		X
Number of lanes/usage (mixed, HOV)	X	X	X	X	X
No. and type of auxiliary lanes		X			X
Capacity (vph)	X		X		X
Free flow speed (mph)	X	X	X	X	X
Traffic Demand Data					
Network Entry Volumes	X	X		X	X
Traffic composition (% trucks, busses, carpools)	X	X		X	X
Veh Occupancy (#persons/veh)	X				
Turning movement counts	X	X		X	X
O-D Table	X		X	X	
Control/Surveillance Data					
Detector/Type Location		X	X	X	X
Fixed-Time Ramp Metering	X	X	X		X
Local Responsive Ramp Metering	X	X			X
System-wide Ramp Metering	X	X		X	X

X: Required data

O: Optional data

TABLE 3. INPUT DATA REQUIRED FOR THE APPLICATION OF SELECTED MODELS: SURFACE STREETS

DATA TYPE	MODEL				
	CORFLO	CORSIM	INTEGRATION	PARAMICS	WATSIM
Network Data					
Node coordinates	X (O)	X (O)	X (O)	X (O)	X (O)
Link length (ft)	X	X	X	X	X
Number of lanes	X	X	X	X	X
Lane usage	X	X	X	X	X
No. and type pockets	X	X			X
Saturation flow (vphg/l)	X	X	X	X	X
Lost time (sec)	X	X	X	X	X
Capacity (vph)					
Free flow speed (mph)	X	X	X	X	X
Pedestrian activity	X	X			X
Traffic Demand Data					
Network Entry Volumes	X	X		X	X
Traffic composition (% trucks, busses, carpools)	X	X		X	X
Veh Occupancy (#persons/veh)	X				
Turning movement counts	X	X		X	X
O-D Table	X		X	X	
Traffic Control Data					
Control device (signal, stop-sign)	X	X	X	X	X
Signal phasing	X	X	X		X
Tming plan (cycle, splits, offsets)	X	X	X		X
Detector type/location	X	X	N/A	X	X
Single-Ring Actuated Controllers	X	X	N/A		X
Dual Ring Actuated Controllers (NEMA. 170)	N/A	X	N/A		X

X:Required data , O:Optional data

3.2.2 Input Data Coding

All the models require that the network is coded into links and nodes. Nodes represent intersections, and **links** one-way traffic streams. CORFLO, CORSIM and WATSim require the data to be coded in a single input file using "record (card) types" to distinguish between the various types of data. INTEGRATION and PARAMICS employ multiple data files, each file corresponding to a specific data category (e.g., link data), and **use** a master file to set the basic parameters for the model execution and specify the names of the various input/output files.

AI but the INTEGRATION model include pre-processors for interactive data entry/editing. These preprocessors (example, the ITRAF software for CORFLO/CORSIM) simplifies the creation and editing of input files through a graphical user interface and on-line help. Input data coding for INTEGRATION is accomplished using any standard text editor.

The differences in the input coding schemes among the different models does not allow to use the same input files on different models, although most of the input data are the same. The exception is the CORFLO and CORSIM models that employ compatible data formats **as** part of the TRAF-modeling system. **Also**, the WATSim model may **use** data files created for the NETSIM (surface street component of CORSIM) with minor modifications.

3.2.3 Model Outputs

Outputs from the CORFLO model includes a fairly extensive set of performance measures (travel time, delay, **speeds**, **fuel** consumption and emissions). A graphics post-processor (GCOR) provides graphical displays with the model results and animation.

CORSIM includes the most comprehensive outputs on traffic performance (travel time, delay, stops, queue lengths) plus environmental impacts for each movement, **link**, network section and the total network. Several graphical displays of results are provided including comparisons of **MOEs** from multiple computer runs, and animation of vehicle movements.

Output from the INTEGRATION model includes travel time for each vehicle type and for each **O-D** pair, number of stops, and **networkwide** values of **fuel** consumption and emissions. The model outputs generally require considerable amount of post-processing through spreadsheets and other software. INTEGRATION provides on-screen animation of vehicle movements throughout the simulation run.

PARAMICS outputs include travel times and other performance measures for each network **link**. The model includes the most comprehensive visual displays for viewing the results through multiple windows, and animation of vehicle movements.

The WATSim model outputs are **s i i a r** to CORSIM. Additional outputs include travel times for each **O-D** pair for each vehicle class. WATSim does not provide displays of the summary results, but it provides an interface to the Microsoft **ACCESS** database management program **so** the user **can** create reports and graphs from the outputs on **link** performance measures. Animation of vehicle movements is **similar** to the **CORSIM** model. Options are available for **3-D** animation at varying levels of realism and background detail.

3.2.4 Computational Aspects

All the models with the exemption of PARAMICS run on PC based microcomputers. CORSIM is operational under the Windows 95/NT operating system. CORFLO, INTEGRATION and WATSim are currently operational under the DOS operating system (a Unix version is also available for INTEGRATION). PARAMICS runs on Unix based workstations.

CORFLO as a macroscopic model has the fastest computer runs times. The computer run time of the rest microscopic models depends on the number of vehicles in the network, output options and control features been simulated. Computer execution times cannot be readily assessed from the literature because of the different computer systems and applications reported.

3.2.5 Lessons From Applications Experiences

Considerable importance was given in the model evaluation process to real-life applications experiences by non-model developers. It was felt that the risk in near-term future model applications would be less with model(s) which: had real-world applications with efforts devoted to calibration and validation; had more model applications by non-model developers, and more associated documented publications.

Following the review of the published literature, a series of phone interviews were conducted with model users to obtain first hand information from the applications of the models. Interview questions focused on the description and assessment of the experiences from the selected model(s), verifying published data, identification of other model users, obtaining information on work that it is still unpublished, and recommendations and future plans on the model usage. An internal project report documenting the information gathering is included in Appendix C.

Table 4 summarizes reported real-life applications of the selected models. Applications experiences between models varied significantly. Some models had limited real-life applications with calibration and validation, and other models were applied only in cooperation with model developers with no detailed documentation of the findings.

3.2.6 Findings

The findings of this evaluation process are summarized below on a model-by-model basis:

INTEGRATION: It appears as the most comprehensive single model for ATMIS applications. Several studies by non-developers have demonstrated most of the model features. Problems were encountered on its application on the Santa Monica freeway corridor. However, the current model version overcomes several of the previous problems and limitations regarding the simulation of traffic flow.

CORSIM: Based on the NETSIM model with several successful applications, and the FRESIM freeway model with a fairly good track record. Enhancements in user interface facilitate its practical application. Continuous support by FHWA and development of a number of control algorithms that can be readily interfaced with the simulation. Main limitation for current version the lack of features for ATIS modeling (extended version under development).

TABLE 4. SELECTED FREEWAY SIMULATION MODELS: REAL-LIFE APPLICATION EXPERIENCES

STATE	MODEL	APPLICATION	ORGANIZATION(S)	YEAR
California	CORFLO	Smart Corridor	JHK Assoc/ Kaku Assoc Los Angeles DOT	1996
	INTEGRATION 1.5	Smart Corridor	UC Berkeley	1993
	PARAMICS	Orange County TestBed	UC Irvine	1997 (ongoing)
	WATSIM WATSIM	I-80/I-680/I-780 San Francisco Embarcadero Network	Korve Engng Korve Engng	1996 1995
Nebraska	CORFLO	I-80: Congestion Management Strategies	Univ Nebraska	1994
Ohio	CORFLO (FREFLO)	I-70 Columbus: Geometric improvements	AEPCO Inc	1992
	CORSIM (FRESIM)	I-70 Columbus: Geometric improvements	AEPCO Inc	1992
Texas	CORFLO	North Dallas Central Expressway: Incident Management	TTI/Texas A&M University	1994
		North Dallas Central Expressway: Transit Operations	TTI/Texas A&M University	1995
Utah	INTEGRATION 2.0	Salt Lake City Traffic Management Plan	Transcore	1996 (ongoing)
Virginia	CORSIM	I-66: Route Diversion Strategies	VTRC	1995
Washington	CORFLO*	I-405 Seattle	Washington DOT	1992

*early mainframe model version

CORFLO: Macroscopic modeling allows for fast execution times and analysis of design and control **scenarios**. Several applications on freeways. The results from the applications in the Santa Monica freeway corridor were questionable. Lack of capabilities for simulating most of **ATMIS** applications

PARAMICS: Innovative software design and features allow for comprehensive simulation of large networks. Applications in **Britain** show promising results. However, there is a lack of applications in the **US**. The ongoing application and validation effort at **UC Irvine** would provide with further evidence of the capabilities of the model **as** a simulation tool.

WATSim: The model is based on the well tested **NETSIM** model with several features to support **ATMIS** applications. However, there is **a** lack of application by non-model developers particularly on modeling freeways.

The findings from the models' evaluation indicate that **CORSIM** and **INTEGRATION** appear as the models with the higher probability of **success** in simulating real-life freeway corridors in the near-term.

CHAPTER 4

DATA ASSESSMENT

This Chapter summarizes the assessment of the data requirements and availability for developing a simulation testbed for the Santa **Monica** freeway corridor. The assessment was performed through review of previous data collection efforts and simulation studies along the corridor, **as well as** review of existing data acquisition systems. Several meetings were held with Caltrans and LADOT staff to **discuss** the data needs and availability. Detailed description of the work performed is included in a project report (Appendix D).

4.1 Data from Previous Simulation Studies

Several data items have already been assembled **as** part of previous simulation studies: a) the LADOT simulation effort using the CORFLO model, and the b) the modeling of the study area using INTEGRATION. Data that have already assembled and coded include:

- o freeway and ramp geometrics
- o arterial and intersection geometrics
- o signal timing plans and ramp metering rates
- o turning movement counts (100 intersections pm ~~peak~~)
- o freeway and ramp volumes
- o arterial link volumes

4.2 Data Requirements and Availability

Tables 2 and 3 in Chapter 3 list the input data requirements for modeling freeway corridors with the CORSIM and INTEGRATION models, into three major categories: network (supply), demand and control. **Most** of the network data are already available and coded for the CORSIM (via the CORFLO database) and INTEGRATION model.

Control data include signal timing plans for the **signalized** intersections, ramp metering rates and queue overrides. The data have already been assembled and coded for the simulation models. However, they need to be checked and updated to reflect recent signal timing/phasing changes. Data on ramp queue overrides (to avoid surface street back-ups) are not normally stored by Caltrans and it would require field observations to accurately simulate ramp metering operations.

The available demand data are quite limited and need updating **because** of the Northridge earthquake and large reductions in the defense industry workforce.

Freeway mainline and ramp volumes: volume and occupancy data (**30 sec**) *can* be obtained **from** the loop detectors. However, a number **of** detectors are not working and require repairs. A procedure **has** been established to automatically receive loop detector data from the Caltrans

ModComp system, but a faster computer would be needed for fast data transmission.

Arterial volumes and intersection turning movements: arterial link volumes **can** be readily obtained **from** the LADOT ATSAC system. Turning movement counts need to be updated. The existing data consist of pm peak counts at approximately 100 intersections collected between 1988 and 1996.

Origin-destination data: an 0-D matrix **has** been prepared by the Southern California Association of Governments (SCAG) based on an 0-D survey of 15,000 households in 1991. The data are available at the census tract level. The data may not be accurate for simulation (particularly with the **INTEGRATION** model) because travel patterns may have changed since 1991, and the sampling rate may not be sufficient to provide reliable estimates for a relatively small area, such **as** the Santa Monica Corridor.

Traffic performance data are also needed to calibrate and validate the simulation models. Travel times on the freeway mainline are not currently available. Link travel times on the arterials were collected during the pm peak period **in** 1995 **to** calibrate the CORFLO model. However, this information may be outdated, and there are no travel time data at other times of the day. Estimates of intersection delay could be obtained from the ATSAC system based on arterial detector data.

4.3 Workplan for Database Development

Developing a database for simulating the Santa Monica freeway corridor with CORSIM or INTEGRATION models would require a **significant** effort. Specific tasks are outlined below (and described in detail in Appendix D:

Supply data: Check the existing information on geometrics, number of lanes, lane utilization and restrictions on the freeway and arterial network.

Control data: Check and update existing ramp metering rates and signal timing plans for each time period of the day for all ramps and intersections in the study area (the existing data apply only to the pm peak and need updating).

Demand data: freeway and arterial volumes need to be collected from the Caltrans TMC and the ATSAC system. Turning movement counts need to be manually collected for each time period (**am**, midday and pm peak) at approximately 400 intersections. Origin-destination information need to be collected using license plate survey data.

Traffic performance data: freeway and arterial travel times on typical routes need to be collected using instrumented vehicles for different time periods.

The effort for developing a comprehensive database for modeling the Santa Monica corridor is estimated at approximately one staff year at a cost of about \$15,000 (with a large portion of the cost involving the conduct of license plate survey for 0-D information).

CHAPTER 5

CONCLUSIONS

This study identified, selected and evaluated existing simulation models for freeway corridors and their capabilities in assessing the effectiveness of current and soon to be available advanced traffic management and traveler information systems. Major emphasis was placed on the modeling approach, input data requirements and experiences from the practical application of the models in real-life situations by non-model developers. The study also performed an assessment of the data needs and availability for developing a simulation testbed for the Santa Monica freeway corridor.

5.1 Summary of the Study Findings

There is a limited number of models that **can** be applied to freeway corridors. Ten candidate models were identified **as** potential simulation tools. Of these models only about one-half of them are operational, available to the user **community**, and have a record of practical application. None of the models is capable of explicitly simulating the impacts of several of the implemented and proposed ATMIS strategies (examples include real-time control, TMC operations and interactions of control and traveler information systems).

Major advancements have occurred in the user friendliness of the models by incorporating graphical user interfaces for interactive data entry, comprehensive output reports, graphical displays of the results, **as well as** animation of vehicle movements. However, most of the data input schemes are incompatible among the different models (with the exception of the TRAF modeling system), and generally there are no facilities for importing data from other software. Examples include AutoCAD highway facility drawings, UTCS signal plans and highway networks already coded for traditional planning models. Thus a significant amount of time and effort **has** to be invested in coding the network for the simulation model.

The applications to-date of the leading simulation models on real-life corridors are very limited. Most of the reported applications have focused on predicting impacts of traveler information systems on **small** areas or synthetic networks. Such applications demonstrate the model features but do not provide any evidence on the usage of the model **as** a practical tool. Furthermore, the documentation of the models practical application is not of sufficient detail to understand problems encountered and suggestions for their resolution.

Of the leading models evaluated, the CORSIM and INTEGRATION models appear **as** the most suitable tools for near-term freeway corridor applications. Both models have continued development support with ongoing enhancements, and more applications by the user **community**.

Proper application of the simulation model(s) require a comprehensive set of input data, and traffic performance data for the comparison of field conditions and model predictions. However, in most practical situations the field data available (especially traffic demand) are incomplete, collected at different time periods, or non-existent (for example, **0-D** flows per time period). **Also**, data are needed

different time periods, or non-existent (for example, **0-D** flows per time period). **Also**, data are needed for the calibration, but the documentation on most of the models does not provide clear guidelines on the sensitivity of model parameters and data requirements for calibration (e.g., jam density, driver aggressiveness factors).

The assessment of the data requirements and availability undertaken for the Santa Monica freeway corridor indicates that a substantial amount of information is already available. However, most of the traffic demand data need to be collected. The effort required to collect both input and traffic performance data for simulating the study area with CORSIM or INTEGRATION is estimated at one person-year.

5.2 Future Work

As a result of **this** research study, a **recommendation has** been made for the application of both the CORSIM and INTEGRATION models to a selected portion of the Santa Monica freeway corridor in Los Angeles for a single **peak period**. **This** real-life application **will** a) provide insights on the model capabilities in simulating the study area, and b) refine the data collection **tasks** based on the actual models usage, before undertaking a **full** scale simulation testbed development.

REFERENCES

CONTRAM model

1. Taylor, N.B., "CONTRAM 5: an Enhanced Traffic Assignment Model," TRRL Research Report 249, Crowthorne, England, 1990.
2. Hounsell, N.B., et al, "Modeling the Dynamics of Route Guidance," 2nd Vehicle Navigation and Information Systems Conference, Oslo, Norway, 1992.
3. Gardes, Y. et al, "Model Selection and Initial Application of CONTRAM model for Evaluating In-Vehicle Information Systems," PATH Report UCB-ITS-PRR-91-11, Institute of Transportation Studies, University of California, Berkeley, 1991.

CORFLO model

4. Payne, H.J., "FREFLO: a Macroscopic Simulation Model of Freeway Traffic," Transportation Research Record 722, 1979.
5. Lieu H., and A.J. Santiago, "CORFLO: An Integrated Traffic Simulation System for Corridors," Traffic Management, Proceedings of the Engineering Foundation Conference, Palm Coast, Florida, 1991.
6. McCoy, P., et al, "Development of Corridor Models for Evaluating Traffic Management Strategies in the Omaha Metropolitan Area," Final Report, University of Nebraska, 1994.

CORSIM model

7. Halati, A., et al, "CORSIM: Microscopic Traffic Simulation Model for Integrated Networks," paper presented at the 76th TRB Annual Meeting, Washington DC, January 1997.
8. FHWA "CORSIM User's Manual, Version 1.0," ITS Research Division, FHWA, US DOT, 1995.
9. Cragg, C.A, and M. Demetsky, "Simulation Analysis of Route Diversion Strategies for Freeway Incident Management," Final Report, Virginia Transportation Research Council, 1995.

DYNASMART model

10. Jayakrishnan, R., et al, "Freeway and Arterial Traffic Simulation Analytically Embedded in Traffic Assignment," paper presented at the 76th TRB Annual Meeting, Washington, DC, January 1997.
11. Jayakrishnan, R., et al, "An Evaluation Tool for Advanced Traffic Information and Management Systems in Urban Networks," Transportation Research C, Vol 2(3), 1994.
12. Mahmassani, H., et al, "Dynamic Traffic Assignment with Multiple User Classes for Real-Time ATMS/ATIS Applications," Advanced Traffic Management Conference, 1993.

INTEGRATION model

13. Van Aerde M., et al, "INTEGRATION: An Overview of Traffic Simulation Features," paper presented at the 75th TRB Annual Meeting, Washington DC, January 1996.

APPENDIX A

BIBLIOGRAPHY ON SIMULATION MODELS

1. CONTRAM Model: 45 References (1978-1996)

- 1.78.01 Leonard, D.R., J.B. Tough, and P.C. Baguley, "CONTRAM: A Traffic Assignment Model for Predicting Flows and Queues during Peak Periods," Report LR841, Transport Research Laboratory, Crowthorne, Berkshire, 1978.
- 1.82.01 Leonard, D.R., and P. Gower, "User Guide to CONTRAM Version 4," Report SR735, Transport Research Laboratory, Crowthorne, Berkshire, 1982.
- 1.82.02 Talbot, M., et al, "The Use of CONTRAM in London," Traffic Engineering & Control, Vol 23(12), 1982.
- 1.83.01 Coombe, R.D., et al, "The Use of CONTRAM in Bahrain," Traffic Engineering & Control, Vol 24(3), 1983.
- 1.84.01 Alfa, A.S., "Modeling the Temporal Distribution of Peak Traffic Demand: State of the Art and Directions," City of Edmonton Transportation Dept., Edmonton, Alta, 1984.
- 1.84.02 Stephenson, B., and S. Teply, "The Verification of CONTRAM in Edmonton," Traffic Engineering & Control, Vol. 25(7/8), 1984.
- 1.86.01 Allard, J., "The use of the CONTRAM Model in Urban Scheme Appraisal," Proc. PTRC Summer Annual Meeting, Seminar R, 1986.
- 1.88.01 Hounsell, N.B., M. McDonald and C.F.S. Wong, "Traffic Incidents and Route Guidance in a SCOOT Network," Proc. PTRC Summer Annual Meeting, Seminar B, 1988.
- 1.89.01 Hounsell, N.B., "Limits to Traffic Growth in Congested Urban Networks," Contractor Report 151, Transport Research Laboratory, Crowthorne, Berkshire, 1989.
- 1.89.02 Leonard, D.R., P. Gower, and N.B. Taylor, "CONTRAM: Structure of the Model," Report RR178, Transport Research Laboratory, Crowthorne, Berkshire, 1989.
- 1.89.03 Taylor, N.B., "Speeding up Quickest-Route Assignments in CONTRAM with an Heuristic Algorithm," Traffic Engineering & Control, Vol 30(2), 1989.
- 1.90.01 Taylor, N.B., "CONTRAM 5: an Enhanced Traffic Assignment Model," Report RR249, Transport Research Laboratory, Crowthorne, Berkshire, 1990.
- 1.91.01 Gardes, Y., B. Haldors, and A.D. May, "Model Selection and Initial Application of CONTRAM for Evaluating In-Vehicle Information Systems," PATH Research Report UCB-ITS-PRR-91-11, University of California Berkeley, 1991.
- 1.91.02 Hounsell, N.B., M. McDonald, and L. Breheret, "Models and Strategies for Dynamic Route Guidance. Part A: The Modeling of Dynamic Route Guidance," DRIVE Conference, Brussels, Belgium, 1991.
- 1.91.03 Smith, M.J. and M.O. Ghali, "A New Dynamic Model for Evaluating the Performance of Urban Traffic Control Systems and Route Guidance Strategies," 70th Annual Meeting, Transportation Research Board, Washington, D.C., 1991.

- 1.92.01 Allen, S.P.R. and S. Alfa, "Adaptation of CONTRAM to the Modeling of Temporal Distribution of Urban Demand," Canadian Journal of Civil Engng, Vol XIX(11), 1992.
- 1.92.02 Harris, S.P., et al, "ROGUS, a Simulation of Dynamic Route Guidance Systems," Traffic Engineering & Control, Vol 33(5), 1992.
- 1.92.03 Hounsell, N.B., S.R. Njoze, and M. McDonald, "Modeling the Dynamics of Route Guidance," Proc. 3rd Vehicle Navigation and Information Systems Conference, Oslo, Norway, 1992.
- 1.92.04 Hounsell, N.B., F. McLeod and M. McDonald, "Dynamic Route Guidance: Some Aspects of Optimisation," Proc. Sixth World Conference on Transport Research, Lyon, France, 1992.
- 1.92.05 Stevens, A., and N.B. Hounsell, "Simulation Modeling of Route Guidance Control Strategies," Proc. 25th ISATA Symposium, Florence, Italy, 1992.
- 1.92.06 Taylor, N.B., "Dynamic Route Guidance with CONTRAM and ROGUS," Proc. PROMETHEUS Workshop on Simulation, Stuttgart, Germany, 1992.
- 1.93.01 Ash, N., "New Modeling Techniques for Assessing Railway Station Designs," Proc. PTRC Summer Annual Meeting, Seminar D, 1993.
- 1.93.02 Greenwood, D.G, and N.B. Taylor, "Parallelising the CONTRAM Traffic Assignment Model," Proc. ESM'93 Simulation MultiConference, Lyon, 1993.
- 1.93.03 Hounsell, N.B., M. McDonald, and S.R. Njoze, "Dynamic Route Guidance and Traffic Incidents," Proc. 26th ISATA Symposium, Aachen, Germany, 1993.
- 1.93.04 Jayakrishnan, R., M.G. McNally, and M.I. Cohen, "Simulation of ATIS Strategies to Reduce non-Recurring Congestion from Special Events," Working Paper 173, University of California Transportation Center, 1993.
- 1.93.05 Mackie, S., and J. Klassen, "The Application of CONTRAM in Resolving Community Traffic Issues," Compendium of Technical Papers, ITE 63rd Annual Meeting, 1993.
- 1.93.06 Milne, D., "The Network Effects of Alternative Road User Charging," Proc. PTRC European Transport Forum, Seminar F, 1993.
- 1.93.07 Robertson, D.I., "Control of Congested Networks in Urban Areas," Proc. FHWA Advanced Traffic Management Conference, Saint Petersburg, Fla, 1993.
- 1.93.08 Taylor, N.B., "CONTRAM 6 Development Objectives," Report PR/TF/11/93, Transport Research Laboratory, Crowthorne, Berkshire, 1993.
- 1.94.01 Bonsall, P., and N.B. Hounsell, "Modeling Drivers' Route Choice Behaviour in the Context of Route Guidance and Information Systems," Proc. First World Congress on Applications of Transport Telematics and Intelligent Vehicle-Highway Systems, 1994.

- 1.94.02 Ghali, M.O., and M. Smith, "Designing Time-of-Day Signal Plans which Reduce Urban Traffic Congestion," *Traffic Engineering & Control*, Vol 35(12), 1994.
- 1.94.03 Hobbs, A., et al, "The Use of VMS for Strategic Network Management--The PLEIADES Experience," *Proc. First World Congress on Applications of Transport Telematics and Intelligent Vehicle-Highway Systems*, 1994.
- 1.94.04 Hounsell, N.B., and S. Ishtiaq, "Journey Time Forecasting for Dynamic Route Guidance Systems," *2nd DRIVE-II Workshop on Short Term Traffic Forecasting*, Delft, Netherlands, 1994.
- 1.94.05 Richardson, C., and R.F., Davies, "Hierarchical Modeling of Urban Traffic Appraisal Using The LTS Model," *Proc. PTRC European Transport Forum, Seminar G*, 1995.
- 1.94.06 Rilett, L. et al, "Evaluation of IVHS options using CONTRAM and INTEGRATION," *Proc. First World Congress on Applications of Transport Telematics and Intelligent Vehicle-Highway Systems*, 1994.
- 1.94.07 Smith, M., et al, "Road Pricing and Traffic Control with Application in York and Cambridge," *Proc. PTRC European Transport Forum, Seminar G*, 1994.
- 1.94.08 Van Vyren, T., and D.R. Leonard, "Urban Congestion Caused by Incidents," *Traffic Engineering & Control*, Vol 35(7/8), 1994.
- 1.94.09 White, C., N.B. Taylor and N.B. Hounsell, "CONTRAM: a Computer Suite for Modeling and Congestion," *Traffic Technology International*, 1994.
- 1.95.01 Blossington, H.K., and D. Tarrand, "The ROMANCE Project," *Proc. Institution of Civil Engineers Conference*, Birmingham, 1995.
- 1.95.02 Harwood, N.W., "Incident Management using MOLA," *IEE Colloquium on Dynamic Control of Strategic Interurban Road Networks*, London, England, 1995.
- 1.95.03 Hounsell, N. B., M. McDonald, and S.R. Njoze, "The Evolution and Evaluation of Dynamic Route Guidance Systems," *Proc. International Conference on Application of New Technology to Transport Systems*, Melbourne, Australia, 1995.
- 1.95.04 Leonard, D.R., "Congestion in Urban Areas Caused by Incidents," *Report TRL126*, Transport Research Laboratory, Crowthorne, Berkshire, 1995.
- 1.95.05 McDonald, M., N.B. Hounsell and S.R. Njoze, "Strategies for Route Guidance Systems Taking Account of Driver Response," *Proc. 6th Vehicle Navigation and Information Systems Conference*, Seattle, Wash, 1995.
- 1.96.01 SNRA, "TANGO Final Report," *Swedish National Road Administration, ARENA*, Goteborg, 1996.
- 1.96.02 Taylor, N.B., "CONTRAM Modeling in the Real-Time Context: A Review and Prognosis," *Report RR/TT/088/96*, Transport Research Laboratory, Crowthorne, Berkshire, 1996.

2. CORFLO Model: 11 References (1991-1996)

- 2.91.01 Lieu, H., A. Santiago and A. Kanaan, "CORFLO, An Integrated Traffic Simulation System for Corridors," Proc. Engineering Foundation Conference, Palm Coast, 1991.
- 2.92.01 Jacobson, E.L., "Evaluation of the TRAF Family of Models: Testing of the CORFLO and FRESIM models," Washington Department of Transportation, 1992.
- 2.92.02 Liu, C.C., and A. Kanaan, "Evaluation of Freeway Improvements Alternatives Using CORFLO," Proc. Conference on Microcomputers in Transportation, Baltimore, Maryland, 1992.
- 2.94.01 Federal Highway Administration, "TRAF-CORFLO Training Course: Participant Workbook," NHI Course No. 13367, Washington DC, 1994.
- 2.94.02 Lee, S. and R. Krammes, 'Corridor Analysis Guidelines for Incident Management,' Research Report 1232-29, Texas Transportation Institute, 1994.
- 2.94.03 McCoy, P.T., et al, "Development of Corridor Models for Evaluating Traffic Management Strategies in the Omaha Metropolitan Area," Final Report TRP-02-31-94, University of Nebraska, 1994.
- 2.95.01 Federal Highway Administration, "CORFLO User's Manual," Washington DC, 1995.
- 2.95.02 Gilmore, J., "ATMS Universal Traffic Operation Simulation," Proc. ITS America 5th Annual Meeting, Vol 1, 1995.
- 2.95.03 Tyler, K.D., et al, "Urban Public Transit Systems Modeling Capabilities," Report SWUTC/95/60040-1, Texas Transportation Institute, 1995.
- 2.96.01 JHK Assoc., and Kaku Assoc., "Lessons Learned from the Trial of the CORFLO Model," Los Angeles, August 1996.
- 2.96.02 Vigen Corp, "CORFLO Cyberbook," prepared for the Federal Highway Administration, Washington DC, 1996.

2A. FREFLO Model--Freeway SubModel of CORFLO: 12 References (1971-1994)

- 2A.71.01 Payne, H.J., "Models of Freeway Traffic and Control," Proc. Mathematics of Public Systems, Vol 1, 1971.
- 2A.79.01 Lieberman, E.B., "Integrated Traffic Simulation Model," Phase I, Vol. 1: Executive Summary, Report FHWA/RD-80/086, 1979.
- 2A.79.02 Payne, H.J., "FREFLO: A Macroscopic Simulation Model of Freeway Traffic," Transportation Research Record 722, 1979.
- 2A.81.01 Payne, H.J., "Calibration and Validation of FREFLO, Volume I: User Calibration Procedures and Supporting Data Analysis," VERAC Report R-001-82, 1981.

- 2A.82.01 Lieberman, E.B., et al, "Analytical Developments for TRAFLO," Report FHWA-RD-80-115, 1982.
- 2A.84.01 Babcock, P.S., D. Auslander, M. Tomizuka, and A.D. May, "Role of Adaptive Discretization in a Freeway Simulation Model," Transportation Research Record 971, 1984.
- 2A.87.01 Rathi, A.K., E.B. Lieberman and M. Yedlin, "Enhanced FREFLO: Simulation of Congested Environments," Transportation Research Record 1112, 1988.
- 2A.92.01 Bui, D.D., P. Nelson, and S.L. Narasimhan, "Computational Realizations of the Entropy Condition in Modeling Congested Traffic Flow," Report 1232-7, Texas Transportation Institute, 1992.
- 2A.92.02 Liu, C.C., A. Kanaan, A. Santiago, and G. Holt, "Macro vs. Micro Freeway Simulation: A Case Study," Compendium of Technical Papers, 62nd ITE Annual Meeting, 1992.
- 2A.92.03 Smith, S., R. Worrall and D. Roden, "Application of Freeway Simulation Models to Urban Corridors," Volume VIII: Executive Summary, Report FHWA RD-92-113, 1992.
- 2A.94.01 Poplaski, R.S., and M. Demetsky, "HOV Systems Analysis," Report VTRC 93-R13, Virginia Transportation Research Council, 1994.
- 2A.94.02 Rao, K.S., and R. Krammes, "Energy-Based Fuel Consumption Model for FREFLO," Transportation Research Record 1444, 1994.

2B. NETFLO^{1/11} Models--SurfaceStreetsSubModels of CORFLO: 4 References (1980-1996)

- 28.80.01 Yedlin, M., and E.B. Lieberman, "Development of a TRANSYT based Traffic Simulation Model," KLD Associates, 1980.
- 2B.83.01 Eiger, A., et al, "Large Scale Traffic System Simulation: An Application of the TRAFLO Model," ITE Journal, Vol 53(7), 1983.
- 2B.92.01 Federal Highway Administration, "TRAF User Reference Guide," Report FHWA-RD-92, Washington DC, 1992.
- 2B.96.01 Taori, S. and A.K. Rathi, "Comparison of NETSIM, NETFLO I and NETFLO II Traffic Simulation Models for Fixed Time Signal Control," Transportation Research Record 1566, 1996.

3. CORSIM Model: 6 References: (1994-1997)

- 3.94.01 Nsour, S. and A. Santiago, "Comprehensive Plan Development for Testing, Calibration, and Validation of CORSIM," Compendium of Technical Papers, 64th ITE Annual Meeting, 1994.
- 3.95.01 Cragg, C.A., and M. Demetsky, "Simulation Analysis of Route Diversion Strategies for Freeway Incident Management," Virginia Transportation Research Council, 1995.
- 3.95.02 Federal Highway Administration, "CORSIM User's Manual, Version 1.0," ITS Research Division, US DOT, Washington DC, 1995.
- 3.96.01 Clark, J., et al., "TRAPHIX: A Graphics Processor for the FHWA Microscopic Traffic Simulation Computer Models," Proc. ITS America 6th Annual Meeting, Vol 1, 1996.
- 3.97.01 Halati, A., et al, "CORSIM: Microscopic Traffic Simulation Model for Integrated Networks," paper presented at the 76th TRB Annual Meeting, Washington, DC, 1997.
- 3.97.02 Owen, L., and C. Stallard, "Evaluation of Real Time Traffic Adaptive Control Prototypes," paper 97116, presented at the 76th TRB Annual Meeting, Washington, DC, 1997.

3A. FRESIM (INTRAS) Model--Freeway SubModel for CORSIM: 27 References (1980-1997)

- 3A.80.01 Wicks, D.A., and E.B. Lieberman, "Developing and Testing of INTRAS: A Microscopic Freeway Simulation Model," Report FHWA/RD-80/106, 1980.
- 3A.88.01 Hamad, A.R., "Computer Simulation Approach to Urban Freeway Control - INTRAS," Proc., IRF Regional Meeting, Saudi Arabia, 1988.
- 3A.89.01 Skabardonis, A., M. Cassidy, A.D. May, and S. Cohen, "Application of Simulation to Evaluate the Operation of Major Freeway Weaving Sections," Transportation Research Record 1225, 1989.
- 3A.90.01 Fazio, J. and N. Roupail, "Conflict Simulation in INTRAS: Application to Weaving Area Capacity Analysis," Transportation Research Record 1287, 1990.
- 3A.91.01 Halati, A., J. Torres and S. Cohen, "FRESIM - A Freeway Simulation Model for Analyzing Operational and Geometric Alternatives," paper presented at the 70th TRB Annual Meeting, Washington DC, January 1991.
- 3A.92.01 Jacobson, E.L., "Evaluation of the TRAF Family of Models: Testing of the CORFLO and FRESIM models," Washington Department of Transportation, 1992.
- 3A.92.02 Leiman, L., B. Ostrom, G. Holmes, and A.D. May, "FREWEV: A Design and Analysis Model for Major Freeway Weaving Sections," Research Report UCB-ITS-RR-92-5, University of California Berkeley, 1992.

- 3A.92.03 Liu, C.C., A. Kanaan, A. Santiago, and G. Holt, "Macro vs. Micro Freeway Simulation: A Case Study," Compendium of Technical Papers, 62nd ITE Annual Meeting, 1992.
- 3A.92.04 Nsour, S.A., S. Cohen, J. Clark, and A. Santiago, "Investigation of the Impacts of Ramp Metering on Traffic Flow with and without Diversion," Transportation Research Record 1365, 1992.
- 3A.92.05 Robinson, B.W., M. Vandehey, G. Mazur, and A.D. May, "Improved Freeway Analysis Techniques: Ramp and Weaving Operations for Freeway Lane Model," Research Report UCB-ITS-RR-92-4F, University of California Berkeley, 1992.
- 3A.92.06 Smith, S., R. Worrall and D. Roden, "Application of Freeway Simulation Models to Urban Corridors," Volume VIII: Executive Summary, Report FHWA RD-92-113, 1992.
- 3A.93.01 Barnes, K.E., "An Alternative Method for Analyzing Merge/Diverge and Weaving Areas on Freeways with Four or More Directional Lanes," Research Report 1232-19, Texas Transportation Institute, 1993.
- 3A.93.02 Fazio, J., J. Holden and N. Roupail, "Use of Freeway Conflict Rates As An Alternative to Crash Rates in Weaving Section Safety Analyses," Transportation Research Record 1401, 1993.
- 3A.93.03 Mekemson, J.R., "FEDIT User Interface for FHWA's TRAF-FRESIM Model," Proc. Conference on Microcomputers in Transportation, Baltimore, Maryland, 1993.
- 3A.94.01 Chang, G.L., J. Wu and H. Lieu, "Real-Time Incident-Responsive System for Corridor Control: Modeling Framework and Preliminary Results," Transportation Research Record 1452, 1994.
- 3A.94.02 Chang, G.L., J. Wu and S. Cohen, "Integrated Real-Time Ramp Metering Model for Nonrecurrent Congestion: Framework and Preliminary Results," Transportation Research Record 1446, 1994.
- 3A.94.03 Chang, G.L., J. Wu and S. Cohen, "Integrated Real-Time Ramp Metering Control for Non-Recurrent Congestion: Modeling and Strategy Development," Proc. ITS America 4th Annual Meeting, 1994.
- 3A.94.04 Cheu, R.L., W. Recker and S. Ritchie, "Calibration of INTRAS for Simulation of 30 sec Loop Detector Output," Transportation Research Record 1457, 1994.
- 3A.94.05 FHWA "FRESIM User Guide", Version 4.5, FHWA, 1994.
- 3A.94.06 Pooran, F.J. and H. Lieu, "Evaluation of System Operating Strategies for Ramp Metering and Signal Coordination," Proc. ITS America 4th Annual Meeting, 1994.
- 3A.95.01 Cragg, C. A., "Simulation Analysis of Route Diversion Strategies for Freeway Incident Management," Virginia Transportation Research Council, 1995.
- 3A.95.02 Dixon, K.K., A. Lorscheider, and J.E., Hummer, "Simulation of 1-95 Lane Closures Using FRESIM," Compendium of Technical Papers, 65th ITE Annual Meeting, 1995.

- 3A.95.03 Gilmore, J., "ATMS Universal Traffic Operation Simulation," Proc. ITS America 5th Annual Meeting, Vol 1, 1995.
- 3A.95.04 Haboian, K.A., "A Case for Freeway Mainline Metering," Transportation Research Record 1494, 1995.
- 3A.95.05 Wang, M.H., and M. Cassidy, "An Electronic Surveillance and Control System for Traffic Management on the Borman Expressway. Part II: Calibrating a Simulation Model," Final Report, Purdue University, 1995.
- 3A.97.01 Payne, H.J., and S. Thompson, "Calibration of FRESIM to Achieve Desired Capacities," paper #971032, presented at the 76th TRB Annual Meeting, January 1997.
- 3A.97.02 Ulerio, J., et al, "Comparative Analysis of FRESIM and 1994 HCM Models for Ramp Junctions Using an Independent Database," paper #971013, presented at the 76th TRB Annual Meeting, January 1997.

3B. NETSIM Model--Surface Streets SubModel of CORSIM: 89 References: (1978-1997)

NETSIM was originally developed in **1978**. Only References after **1987** are listed

- 3B.87.01 Andrews, B., and E.B. Lieberman, "GTRAF: The NETSIM Graphics System," Proc. North American Conference on Microcomputers in Transportation, 1987.
- 3B.88.01 Carter, E.C., "Signal Systems: Methodology for Project Selection," Volume I-Summary Report, University of Maryland, 1988.
- 3B.88.02 Carter, E.C., "Signal Systems: Methodology for Project Selection," Volume II-Final Report, University of Maryland, 1988.
- 3B.88.03 Hajjiri, S.A., and Y. Stephanedes, "Urban Congestion Reduction for Energy Conservation: Control Strategies for Urban Street Systems - A State of the Art," Final Report, University of Minnesota, 1988.
- 3B.88.04 Kastelic, T., "Multicriteria Approach to the Installation of Traffic Signal Devices Based on Traffic Flow Simulation," Yugoslavia Meeting, 1988.
- 3B.88.05 Rathi, A.K., "A Control Scheme for High Traffic Density Sectors," Transportation Research B, Vol 22B(2), 1988.
- 3B.88.06 Roupail, N. M., "Delay Models for Mixed Platoon and Secondary Flows," Journal of Transportation Engineering, Vol 114(3), 1988.
- 3B.88.07 Sadegh, A., and E. Radwan, "Comparative Assessment of 1985 HCM Delay Model, Journal of Transportation Engineering, Vol 114(2), 1988.
- 3B.88.08 Skabardonis, A., "Progression Through a Series of Intersections with Traffic Actuated Controllers," Vol. 1 Technical Report, FHWA RD-89-132, 1988.

- 3B.88.09 Skabardonis, A., "Progression Through a Series of intersections with Traffic Actuated Controllers," Vol. 2 User's Guide, Report FHWA RD-89-133, 1988.
- 38.88.10 Yauch, P.J., J.C. Gray, and W.A. Lewis, "Using NETSIM to Evaluate the Effects of Drawbridge Openings on Adjacent Intersections," ITE Journal, Vol 58(5), 1988.
- 3B.89.01 Luk, J.Y.K., "Modelling and Monitoring the Performance of Urban Traffic Control System," Australian Road Research Report, 1989.
- 38.89.02 Rathi, A.K. and A. Santiago, "The New NETSIM Simulation Program," Traffic Engineering & Control, Vol 31(5), 1990.
- 3B.89.03 Rathi, A.K., and E.B. Lieberman, "Effectiveness of Traffic Restraint for a Congested Urban Network: A Simulation Study," Transportation Research Record 1232, 1989.
- 3B.90.04 Rathi, A.K., and A. Santiago, "Urban Network Traffic Simulation: TRAF-NETSIM Program," Journal of Transportation Engineering, Vol 116(6), 1990.
- 38.89.05 Rymer, B., T. Urbanik and J.C. Cline, "Delay at Light Rail Transit Grade Crossings," TRB Special Report 221, 1989.
- 38.90.03 Radwan, A.E., and R.L. Hatton, "Evaluation Tools of Urban Interchange Design and Operation," Transportation Research Record 1280, 1990.
- 38.90.04 Rathi, A.K., et al, "ITDS: Past, Present, and Future," Journal of Transportation Engineering, Vol.116(6), 1990.
- 38.90.02 Wong, J., "Comparing Capacities and Delays Estimated by Highway Capacity Software and TRAF-NETSIM to Field Results," Compendium of Technical Papers, 60th ITE Annual Meeting, 1990.
- 38.90.05 Wong, S.Y., "TRAF-NETSIM: How it Works, What it Does," ITE Journal, Vol 60(4), 1990.
- 3B.90.06 Rathi, A.K., and A. Santiago, "Identical Traffic Streams in the TRAF-NETSIM Simulation Program," Traffic Engineering & Control, Vol 31(6), 1990.
- 38.90.07 Chang, G.L., and A. Kanaan, "Variability Assessment for TRAF-NETSIM," Journal of Transportation Engineering, Vol 116(5), 1990.
- 3B.90.08 Mahmassani, H.S., et al, "Microscopic Simulation of Traffic in Networks: Supercomputer Experience," Journal of Computing in Civil Engineering, Vol 4(1), 1990.
- 38.90.09 Kim, Y., "Development of Optimization Models for Signalized intersections During Oversaturated Conditions," PhD Thesis, Texas A&M University, 1990.
- 38.91.01 Hummer, J.E., and T.D. Thompson, "Simulation of Arterial Left Turn Alternatives," Report No 61, University of North Carolina, 1991.
- 3B.91.02 Bruce, E.L. and J.E. Hummer, "Delay Alleviated by Left-Turn Bypass Lanes," Transportation Research Record 1299, 1991.

- 3B.91.03 Chatterjee, A., et al, "Highway Cross Sections: Median Versus Two-way Left-Turn Lane Designs," Final Report, University of Tennessee, 1991.
- 3B.91.04 Sulzberg, J.D., and M. Demetsky, "Demonstration of TRAF-NETSIM for Traffic Operations Management," Virginia Transportation Research Council, 1991.
- 3B.91.05 Miller, H.J., and M. Demetsky, "Evaluation of Roadway Sites for Queue Management," Final Report, Virginia Transportation Research Council, 1991.
- 3B.91.06 Wong, S.L., "Capacity and Level of Service By Simulation-A Case Study of TRAF-NETSIM," 1st International Symposium of Highway Capacity, Karlsruhe, Germany, 1991.
- 3B.91.07 Rathi, A.K., and M. Venigalla, "Variance Reduction Applied to Urban Network Traffic Simulation," Oak Ridge National Laboratory, 1991.
- 3B.92.01 Berry, R.A., et al, "Traffic and Light Rail Transit: Methods of Analysis for DART's North Central Corridor," Transportation Research Record 1361, 1992.
- 3B.92.02 Courage, K.G., "Determination of an Optimal Analytical Intersection Design Procedure," Final Report, University of Florida, 1992.
- 3B.92.03 Dunn, R.C.M., "Calibration of NETSIM to New Zealand Conditions," University of Auckland, 1992.
- 3B.92.04 Fisk, C.S., and R.C.M. Dunn, "Urban Road Traffic Models for Economic Appraisal," University of Auckland, 1992.
- 3B.92.05 Kim, Y., and C. Messer, "Traffic Signal Timing Models for Oversaturated Signalized Interchanges," Interim Report, Texas Transportation Institute, 1992.
- 3B.92.06 Rathi, A.K., "The Use of Common Random Numbers to Reduce the Variance in Network Simulation of Traffic," Transportation Research B, Vol 26B(5), 1992.
- 3B.92.07 Rathi, A.K., and M. Venigalla, "Variance Reduction Applied to Urban Network Traffic Simulation," Transportation Research Record 1365, 1992.
- 3B.92.08 Santiago, A., and A.K. Rathi, "Simulation and Intelligent Vehicle Highway Systems," Proc. 3rd Vehicle Navigation Conference, Oslo, Norway, 1992.
- 3B.92.09 Wiley, M., and C.S. Papacostas, "Comparison of TRAF-NETSIM with HCM Techniques to Estimate Traffic Impacts in the Preparation of Environmental Documents," Compendium of Technical Papers, 62nd ITE Annual Meeting, 1992.
- 3B.92.10 Venigalla, M.M., et al, "Operational Effects of Nontraversable Medians and Two-way Left-Turn Lanes: A Comparison," Transportation Research Record 1356, 1992.
- 3B.93.01 Athanailos, E. et al, "The Integration of the Highway Capacity Manual and the TRAF-NETSIM Simulation Model," Proc. Conference on Microcomputers in Transportation, Baltimore, Maryland, 1993.

- 38.93.02 Bieberitz, J.A. et al, " A Two-way Traffic Feasibility Analysis," Proc. Conference on Microcomputers in Transportation, Baltimore, Maryland, 1993.
- 3B.93.03 Chang, G.L., and C. Chin, "Ranking and Selection of Alternatives with Microscopic Traffic Simulation Models - A Case Study of TRAF-NETSIM," paper presented at the 72nd TRB Annual Meeting, 1993.
- 38.93.04 Denney, R.W., et al, "NETSIM for a CBD Using the Two Fluid Model," Proc. FHWA Large Urban Systems Conference, St. Petersburg, Florida, 1993.
- 38.93.05 Helati, K.N., and K. Khan, "Regression-Based Urban Arterial Road Delay Models," Canadian Journal of Civil Engineering, Vol XX(1), 1993.
- 38.93.06 Jacobson, K.L., "Transit Signal Priority Treatments in the Puget Sound Region," ASCE Pacific Rim Transtech Conference, Seattle, Washington, 1993.
- 38.93.07 Luedtke, P., et al, "Simulating DART's North Central Light Rail Line Using TRAF-NETSIM," Compendium of Technical Papers, 63rd ITE Annual Meeting, 1993.
- 38.93.08 Malakapalli, M.P., and C. Messer, "Enhancements to the PASSER 1190 Delay Estimation Procedures," Transportation Research Record 1421, 1993.
- 38.93.09 Nihan, N.L., and H.C. Chen, "HOV Improvements on Signalized Arterials in the Seattle Area," Final Report, Vol IV, University of Washington, 1993.
- 3B.93.10 Papacostas, C.S. and M. Wiley, "Use of TRAF-NETSIM to Estimate the Traffic Impacts of an Urban Resort Area Development," Proc. Conference on Microcomputers in Transportation, Baltimore, Maryland, 1993.
- 38.93.11 Poglod, K. "Analysis with Micro Simulation Model for the Regulation of Traffic," Transport Miejski, Warszawa, Poland, 1993.
- 38.93.12 Waugh, M.R., et al, "Using TRAF-NETSIM to Analyze Clean Air Impacts," Compendium of Technical Papers, 63rd ITE Annual Meeting, 1993.
- 38.94.01 Athanailos, E.G., "The integration of the Highway Capacity Manual and the TRAF-NETSIM Simulation Model," ITE Journal, Vol 64(5), 1994.
- 38.94.02 Benekohal, R.F., and G. Abu-Lebdeh, "Variability Analysis of Traffic Simulation: Practical Approach for TRAF-NETSIM," Transportation Research Record 1457, 1994.
- 38.94.03 Berry, R.A., and C. Walters, "Development of Analytical Tools for Evaluating Operations of Light Rail At-Grade Within an Urban Signal System," Interim Report 3, Texas Transportation Institute, 1994.
- 3B.95.04 Bieberitz, J.A., "Neighborhood Traffic Control - Do You Really Want a Traffic Signal?," Compendium of Technical Papers, 65th ITE Annual Meeting, 1995.
- 38.94.05 Bhat, C.S., "Effects of Geometric and Control Features of Network Traffic: A Simulation Study," Dissertation, University of Texas at Arlington, 1994.

- 3B.94.06 Chang, G.L., L. Zhuang and C. Perez, "Permitted Left-Turn Capacity of Exclusive Lanes: Simulation-Based Method," Transportation Research Record 1457, 1994.
- 3B.94.07 Goldblatt, R., et al, "Continuous Flow Intersections," ITE Journal, Vol 64(7), 1994.
- 3B.94.08 Robinson, T., M. Yedlin and R. Goldblatt, "3 Dimensional Animation of Simulated Traffic Operations," Traffic Technology International, 1994.
- 3B.94.09 Sisiopiku, V.P., N. Rouphail and A. Santiago, "Analysis of Correlation Between Arterial Travel Time and Detector Data from Simulation and Field Studies," Transportation Research Record 1457, 1994.
- 3B.94.10 Stephanedes, Y. T., and E. Kwon, "Development and Application of On-line Strategies for Optimal Intersection Control," Final Report, University of Minnesota, 1994.
- 3B.94.11 Stephanedes, Y.T., and E. Kwon, "Development and Application of On-line Strategies for Optimal Intersection Control," Phase 2. Off-line Evaluation of Control Strategies and Development of a Live Laboratory, University of Minnesota, 1994.
- 3B.94.12 Venglar, S.P. and D. Fambro, "Development of Analytical Tools for Evaluating Operations of Light-Rail At-Grade Within an Urban Signal System," Interim Report 2, Texas Transportation Institute, 1994.
- 38.95.01 Bauer, T., et al, "Testing of Light Rail Signal Control Strategies by Combining Transit and Traffic Simulation Models," Transportation Research Record 1494, 1995.
- 3B.95.02 Boone, J.L., and J.E. Hummer, "Calibrating and Validating Traffic Simulation Models for Unconventional Arterial Intersection Designs," Transportation Research Record 1500, 1995.
- 3B.95.03 Gilmore, J., "ATMS Universal Traffic Operation Simulation," Proc. ITS America 5th Annual Meeting, Vol 1, 1995.
- 3B.95.04 Hummer, J.E., and J.L. Boone, "Travel Efficiency of Unconventional Suburban Arterial intersection Designs," Transportation Research Record 1500, 1995.
- 3B.95.05 Joshi, S.S. and A.K. Rathi, "Statistical Analysis and Validation of Multipopulation Traffic Simulation Experiments," Transportation Research Record 1510, 1995.
- 3B.95.06 Lin, L.T, "A Methodology and Computer-Aided System for Signal Grouping of Computerized Traffic Signal Design," Proc. 28th Symposium, Stuttgart, Germany, 1995.
- 3B.95.07 Paksarsawan, S., A. May and F. Montgomery, "Simulation of Driver Behaviour at Junctions in the Bangkok Network," Traffic Engineering & Control, Vol 36(10), 1995,
- 3B.95.08 Venglar, S.P., D. Fambro and T. Bauer, "Validation of Simulation Software for Modeling Light Rail Transit," Transportation Research Record. 1494, 1995.
- 3B.96.01 Arnold, E.D., and G.C. McGhee, "Review and Evaluation of Methods for Analyzing Capacity at Signalized Intersections," Report VTRC 96-R16, Virginia Transportation Research Council, 1996.

- 3B.96.02 Al-Sahili, K., and W.C. Taylor, "Evaluation of Bus Priority Signal Strategies in Ann Arbor, Michigan," Transportation Research Record 1554, 1996.
- 3B.96.03 Chung, J.H. and K. Goulias, "Access Management Using GIS and Traffic Management Tools in Pennsylvania," Transportation Research Record 1551, 1996.
- 3B.96.04 Garber, N., "Comparison of the Operational Characteristics of the Single Point Urban and Diamond Interchanges," Virginia Transportation Research Council, 1996.
- 3B.96.05 Khasnabis, S., et al, "NETSIM-Based Approach to Evaluation of Bus Preemption Strategies," Transportation Research Record 1554, 1996.
- 3B.96.06 Messer, C.J. and R.V. Nageswara, "Improved Signal Coordination Strategies for Actuated Control," Report SWUTC/96/465110-1, Texas Transportation Institute, 1996.
- 3B.96.07 Shaik, R.A., "Efficiency of Dual Left-Turn Lane Intersections in Charlotte A Study Using TRAF-NETSIM," ITE Journal, Vol 66(4), 1996.
- 3B.96.08 Skabardonis, A., "Estimating the Impacts of Signal Hardware Improvements," Transportation Research Record 1554, 1996.
- 3B.96.09 Skabardonis, A., "Determination of Timings in Signal Systems with Traffic Actuated Controllers," Transportation Research Record 1554, 1996.
- 3B.96.10 Tsao, S.M, et al, "An Analysis of Interfacing Between Signal Subnetworks," Journal of Advanced Transportation, Vol 30(1), 1996.
- 38.96.11 Yedlin, M. and E.B. Lieberman, "Recent and On-going Enhancements to TRAF-NETSIM," PATH Report 63-C12, University of California Berkeley, 1996.
- 3B.97.01 Chidambaram, S., and Y. Stefanedes, "Development and Simulation Based Testing of Intersection Incident Detection Algorithms," paper 970929, presented at the 76th TRB Annual Meeting, Washington DC, January 1997.
- 3B.97.02 Davis, C.F., et al, "Application of Multi-criteria Decision Making and Risk Analysis to Congestion Management," paper 970951, presented at the 76th TRB Annual Meeting, Washington DC, January 1997.
- 3B.97.03 Khasnabis, S., "Optimal Bus Headways for Preemption: A Simulation Approach," paper 970248, presented at the 76th TRB Annual Meeting, Washington DC, January 1997.
- 3B.97.04 Roupail, N., et al, "Validation of a Generalized Model for Vehicle-Actuated Traffic Signals," paper 970837, presented at the 76th TRB Annual Meeting, Washington DC, January 1997.
- 3B.97.05 Skabardonis, A., "A Modeling Framework for Estimating Emissions in Large Urban Areas," Transportation Research Record 1587, 1997.

4. DYNASMART Model: 19 References (1988-1997)

- 4.88.01 Chang, G.L., and H.S. Mahmassani, "Travel Time Prediction and Departure Time Behavior Dynamics in a Congested Traffic System," *Transportation Research B*, Vol. 22B(3), 1988.
- 4.88.02 Mahmassani, H.S., and R. Jayakrishnan, "Dynamic Analysis of Lane Closure Strategies," *Journal of Transportation Engineering*, Vol. 114 (4), 1988.
- 4.91.01 Mahmassani, H.S., and R. Jayakrishnan, "System Performance and User Response under Real-Time Information in a Congested Traffic Corridor," *Transportation Research A*, Vol. 25A(5), 1991.
- 4.92.01 Jayakrishnan, R., "In-Vehicle Information Systems for Network Traffic Control : a Simulation Framework to Study Alternative Guidance Strategies," Dissertation, University of Texas at Austin, 1992.
- 4.93.01 Jayakrishnan, R., et al, "A Simulation based Framework for the Analysis of Traffic Networks Operating with Real Time Information," PATH Research Report UCB-ITS-PRR-93-25, University of California Berkeley, 1993.
- 4.93.02 Jayakrishnan, R., M.G. McNally, and M.I. Cohen, "Simulation of ATIS Strategies to Reduce non-Recurring Congestion from Special Events," Working paper no. 173, University of California Transportation Center, 1993.
- 4.93.03 Mahmassani, H.S., et al., "Dynamic Traffic Assignment with Multiple User Classes for Real-Time ATIS/ATMS Applications," Proc. FHWA Advanced Traffic Management Conference, Saint Petersburg, Fla., 1993.
- 4.93.04 Mahmassani, H.S., et al., "Effect of Real-Time Information on Network Performance Under Alternative Dynamic Assignment Rules," Proc. PTRC Summer Annual Meeting, Seminar D, 1993.
- 4.94.01 Jayakrishnan, R., H.S. Mahmassani and T.Y. Hu, "An Evaluation Tool for Advanced Traffic Information and Management Systems in Urban Areas," *Transportation Research C*, Vol. 2C(3), 1994.
- 4.94.02 Jayakrishnan, R., et al., "Faster Path-Based Algorithm for Traffic Assignment," *Transportation Research Record* 1443, 1994.
- 4.94.03 Lasdon, L.S., and S. Luo, "Computational Experiments with a System Optimal Dynamic Traffic Assignment Model," *Transportation Research C*, Vol. 2C(2), 1994.
- 4.94.04 Mahmassani, H.S., "Microsimulation-based Procedures for Dynamic Network Traffic Assignment Transportation Planning Methods," Proc. PTRC European Transport Forum, Seminar H, 1994.

- 4.94.05 Mahmassani, H.S., et al, "Development and Testing of Dynamic Traffic Assignment and Simulation Procedures for ATIS/ATMS Applications," Technical Report DTFH61-90-R-00074-FG, University of Texas at Austin, 1994.
- 4.95.01 Acha, D.J., R. Moore and H.S. Mahmassani, "Assessment of Congestion Pricing for Reducing Urban Congestion and Improving Air Quality," Report FHWA/TX-95-132-1 F, University of Texas at Austin, 1995.
- 4.95.02 Hu, T.Y., and H.S. Mahmassani, "Evolution of Network Flows under Real-Time Information: Day-to-Day Dynamic Simulation Assignment Framework," Transportation Research Record 1493, 1995.
- 4.95.03 Jayakrishnan, R., W.K. Tsai, and A. Chen, "A Dynamic Traffic Assignment Model with Traffic Flow Relationships," Transportation Research C, Vol. 3C(1), 1995.
- 4.95.04 Peeta, S., and H.S. Mahmassani, "Multiple User Classes Real-Time Traffic Assignment for Online Operations: A Rolling Horizon Solution Framework," Transportation Research C, Vol 3C(2), 1995.
- 4.96.01 Jayakrishnan, R., et al, "Enhancements to a Simulation Framework for Analyzing Urban Traffic Networks with ATIS/ATMS," PATH Research Report UCB-ITS-PRR-96-27, University of California Berkeley, 1996.
- 4.97.01 Jayakrishnan, R., et al, "Freeway and Arterial Traffic Simulation Analytically Embedded in Dynamic Assignment," paper #971342, presented at the 76th TRB Annual Meeting, Washington, DC, 1997.

5. INTEGRATION Model: 52 References (1985-1996)

- 5.85.01 Van Aerde, M., "Modeling of Traffic Flows, Assignment and queueing in Integrated Freeway/Traffic Signal Networks," Dissertation, University of Waterloo, 1985.
- 5.88.01 Van Aerde, M., and E.R. Case, "Individual driver Route Guidance Systems and their implications for Traffic Control," Canadian Journal of Civil Engng, Vol 15(2), 1988.
- 5.88.02 Van Aerde, M., and S. Yagar, "Dynamic Integrated Freeway/Traffic Signal Networks: a Routing-based Modeling Approach," Transportation Research A, Vol 22A(6), 1988.
- 5.88.03 Van Aerde, M., and S. Yagar, "Dynamic Integrated Freeway/Traffic Signal Networks: Problems and Proposed Solutions," Transportation Research A, Vol 22A (6), 1988.
- 5.88.04 Van Aerde, M., and Y. Blum, "Electronic Route Guidance in Congested Networks," ITE Journal, Vol 58(8), 1988.
- 5.89.01 Blum, Y., M. Van Aerde, and E.R Case, "Considerations for the Application of a Route Guidance System in the Greater Toronto Area," Proc. 1st Vehicle Navigation and Information Systems Conference, Toronto, Ont., 1989.
- 5.89.02 Van Aerde, M., and H. Rakha, "Development and Potential of System Optimized Route Guidance Strategies," Proc. 1st Vehicle Navigation and Information Systems Conference, Toronto, Ont., 1989.
- 5.89.03 Van Aerde M., et al., "Managing Traffic Congestion in Combined Freeway and Traffic Signal Networks," ITE Journal, Vol 59(2), 1989.
- 5.89.04 Van Aerde, M., J. Voss, and Y. Blum, "Modeling the Burlington Skyway FTMS during Recurring and non-Recurring Traffic Congestion," Traffic Engineering & Control, Vol 30(5), 1989.
- 5.89.05 Van Aerde, M., J. Voss, and G. Noxon, "On-line Generation of Synthetic Origin-Destination Counts for Application in Freeway Corridor Traffic Control," Transportation Research Record 1236, 1989.
- 5.90.01 Van Aerde, M. and S. Yagar, "Combining Traffic Management and Driver Information in Integrated Traffic Networks," Proc. IEE International Conference on Road Traffic Control, London, England, 1990.
- 5.90.02 Van Aerde, M. and Y. Blum, "Electronic Driver Route Guidance in Congested Networks using pre-Trip Planners, Changeable Message Signs and on-board Systems," Technical papers from ITE's 1990, 1989, and 1988 conferences, 1990.
- 5.90.03 Van Aerde, M., "Modeling of Integrated Traffic Networks using the INTEGRATION Simulation Model," Ontario Ministry of Transportation, R&D Branch, 1990.
- 5.90.04 Van Aerde, M., J. Voss and Y. Blum, "Modeling the Burlington Skyway FTMS during Recurring and non-Recurring Traffic Congestion," Proc. Engineering Foundation Conference, 1990.

- 5.91.01 Case, E.R., M. Van Aerde, and M. Krage, "Supporting Routines for Modelling the Traffic Responsive Features of the TravTek System using INTEGRATION," Proc. 2nd Vehicle Navigation and Information Systems Conference, Dearborn, Mich., 1991.
- 5.91.02 Rakha, H.M., M. Van Aerde, and E.R. Case, "Real-Time Incremental Coordination of Traffic Signals using TRANSYT-7F," Proc. Engineering Foundation Conference, Palm Coast, Fla., 1991.
- 5.91.03 Rilett, L. and M. Van Aerde, "Route Based Anticipated Travel Times," Proc. Applications of Advanced Technologies in Transportation Engineering, ASCE, 1991.
- 5.91.04 Rilett, L.R. and M. Van Aerde, "Modelling distributed Real-Time Route Guidance Strategies in a Traffic Network that Exhibits the Braess Paradox," Proc. 2nd Vehicle Navigation and Information Systems Conference, Dearborn, Mich., 1991.
- 5.91.05 Rilett, L.R., "Simulating the TravTek Route Guidance Logic using the INTEGRATION Traffic Model," Proc. 2nd Vehicle Navigation and Information Systems Conference, Dearborn, Mich., 1991.
- 5.91.06 Van Aerde, M., G. MacKinnon, and B. Hellinga, "The Generation of Synthetic O-D Demands from Real-Time Vehicle Probe Data: Potential and Limitations," Proc. 2nd Vehicle Navigation and Information Systems Conference, Dearborn, Mich, 1991.
- 5.93.01 Gardes, Y., et al, "Application of the INTEGRATION Model to Demonstrate the Simulation of Advanced Traveler Information Systems," paper 930474, 72nd TRB Annual Meeting, January 1993.
- 5.93.02 Gardes, Y., and A.D. May, "Simulation of IVHS on the Smart Corridor using the INTEGRATION Model. Phase 1, Initial Investigations," PATH Research Report UCB-ITS-PRR-93-3, University of California at Berkeley, 1993.
- 5.93.03 Gardes, Y., and A.D. May, "Simulation of IVHS on the Santa Monica Freeway Corridor using the INTEGRATION Model. Phase 2, Preliminary ATIS and ATMS Experiments," PATH Working Paper UCB-ITS-PWP-93-6, University of California at Berkeley, 1993.
- 5.93.04 Gardes, Y., A.D. May, and M. Van Aerde, "Simulation of IVHS on the Smart Corridor," Compendium of Technical Papers, 63rd ITE Annual Meeting, 1993.
- 5.93.05 Rilett, L.R., and M. Van Aerde, "Modeling Route Guidance systems using the INTEGRATION Model," Pacific Rim TransTech Conference, Seattle, Wash., 1993.
- 5.93.06 Van Aerde, M., and M. Baker, "Modeling Fuel Consumption and Vehicle Emissions for the TravTek System," Proc. 4th Vehicle Navigation and Information Systems Conference, Ottawa, Ont., 1993.
- 5.93.07 Van Aerde, M. et al, "Vehicle Probes as Real-Time ATMS Sources of Dynamic O-D and Travel Time data," Proc. FHWA Advanced Traffic Management Conference, Saint Petersburg, Fla., 1993.

- 5.93.08 Yagar, S., "INTEGRATION - A Critique," Proc. FHWA Advanced Traffic Management Conference, Saint Petersburg, Fla., 1993.
- 5.94.01 Bacon, V.W., "Using the INTEGRATION Model with Transportation Planning Software and Geographic Information Systems," Dissertation, University of California Berkeley, 1994.
- 5.94.02 Bacon V.W., et al, "Use of INTEGRATION Model to Study High Occupancy Vehicle Facilities," Transportation Research Record 1446, 1994.
- 5.94.03 Bloomberg L.D. and A.D. May, "Simulation Modeling of the Santa Monica Freeway," PATH Working Paper UCB-ITS-PWP-94-149, University of California Berkeley, 1994.
- 5.94.04 Hellinga, B., "An Overview of a Simulation Study of the Highway 401 Freeway Traffic Management System," Canadian Journal of Civil Engineering, Vol XXI(3), 1994.
- 5.94.05 Hellinga, B., and M. Van Aerde, "Statistical Analysis of the Reliability of using RGS Vehicle Probes as Estimators of Dynamic O-D Departure Rates," IVHS Journal, Vol. 2(1), 1994.
- 5.94.06 MacKinnon, G., A. Kanaan and M. Van Aerde, "Evaluating the Impacts of Implementing Electronic Toll Collection using INTEGRATION," Proc. First World Congress on Applications of Transport Telematics and Intelligent Vehicle-Highway Systems, 1994.
- 5.95.01 Bacon V.W, J.R. Windover, and A.D. May, "Investigating Intelligent Transportation Systems Strategies on the Santa Monica Freeway Corridor," PATH Research Report UCB-ITS-PRR-95-38, University of California Berkeley, 1995.
- 5.95.02 Bacon V.W, J.R. Windover, and A.D. May, "Investigating Intelligent Transportation Systems Strategies on the Santa Monica Freeway Corridor: Technical Appendix," PATH Research Report UCB-ITS-PRR-95-39, University of California Berkeley, 1995.
- 5.95.03 Baker, M., and M. Van Aerde, "Microscopic Simulation of EPA Fuel and Emission Rates for Conducting IVHS Assessments," Proc. ITS America 5th Annual Meeting, 1995.
- 5.95.03 Hellinga, B., H. Rakha and M. Van Aerde, "Coupled Evaluation of Communication System loading and ATIS/ATMS Efficiency," Proc. 6th Vehicle Navigation and Information Systems Conference, Seattle, Wash., 1995
- 5.95.04 Hellinga, B., and M. Van Aerde, "Examining the Potential of Using Ramp Metering as a Component of an ATMS," Transportation Research Record 1494, 1995.
- 5.95.05 Marcus, C.J., "The use of Simulation Models on the Central Artery/Third Harbor Tunnel Project," Proc. 6th Navigation and Information Systems Conference, Seattle, Wash., 1995.
- 5.95.06 Rakha, H., and M. Van Aerde, "Accuracy of Vehicle-Probe Estimates of Link-Travel Time and Instantaneous Speed," Proc. ITS America 5th Annual Meeting, 1995.

- 5.95.07 Rakha, H., and M. Van Aerde, "REALTRAN: an off-line Emulator for Estimating the Effects of SCOOT," Transportation Research Record 1494, 1995.
- 5.95.08 Robinson, M. and M. Van Aerde, "Examining the Delay and Environmental Impacts of Toll Plaza Characteristics," Proc. 6th Vehicle Navigation and Information Systems Conference, Seattle, Wash. 1995.
- 5.95.09 Van Aerde, M., and H. Rakha, " Multivariate Calibration of Single Regime Speed-Flow-Density Relationships," Proc. 6th Vehicle Navigation and Information Systems Conference, Seattle, Wash. 1995.
- 5.95.10 Van Aerde, M., "INTEGRATION Release 2: User's Guide," 3 Vols, Transportation Systems Research Group, Queens University, 1995.
- 5.96.01 Bercam, E.C., "The Application of Dynamic Assignment in the Netherlands using the INTEGRATION Model," Proc. PTRC Summer Annual Meeting, Seminars D&E, 1996.
- 5.96.02 Rakha, H., and M. Van Aerde, "Comparison of Simulation Modules of TRANSYT and INTEGRATION Models," Transportation Research Record 1572, 1996.
- 5.96.03 Stewart, J., M. Baker, and M. Van Aerde, "Evaluating Weaving Section Designs Using INTEGRATION," Transportation Research Record 1555, 1996.
- 5.96.04 Van Aerde, M. and H. Rakha, "TravTek Evaluation Modeling Study," Federal Highway Administration, NTIS, Springfield, Va, 1996.
- 5.96.05 Van Aerde, M., et al, "INTEGRATION: An Overview of Traffic Simulation Features," paper presented at the 75th TRB Annual Meeting, Washington DC, January 1996.
- 5.96.06 Velan, S., and M. Van Aerde, "Gap Acceptance and Approach Capacity at Unsignalized Intersections," ITE Journal, Vol 66(3), 1996.
- 5.96.07 Yu, L. and M. Van Aerde, "Dynamic Modeling of Traffic Networks in Route Guidance for System Optimal and User Equilibrium," Proc. ITS America 6th Annual Meeting, 1996.

6. METACOR/METANET Model: 7 References (1990-1994)

- 6.90.01 Messmer, A., and M. Papageorgiou, "METANET, a Macroscopic Simulation Program for Motorway Networks," *Traffic Engineering & Control*, Vol 31(9), 1990.
- 6.90.02 Papageorgiou, M., "Dynamic Modeling, Assignment, and Route Guidance in Traffic Networks," *Transportation Research B*, Vol. 24B(6), 1990.
- 6.90.03 Papageorgiou, M., et al, "Modeling and Real Time Control of Traffic Flow on the Southern Part of Boulevard Peripherique in Paris. Part 1: Modeling," *Transportation Research A*, Vol 24A(5), 1990.
- 6.90.04 Technical University of Munich, "METANET, a Simulation Program for Motorway Networks," *Documentation*, 1990.
- 6.91.01 Morin J.M., et al, "Motorway Networks, Modelling and Control," *DRIVE Conference, Advanced Telematics in Road Transport*, Brussels, Belgium, 1991.
- 6.94.01 Haj Salem, H., et al, "METACOR: a Macroscopic Modeling Tool for Urban Corridors," *Proc. First World Congress on Applications of Transport Telematics and Intelligent Vehicle-Highway Systems*, 1994.
- 6.94.02 Haj Salem, H., et al, "The use of METACOR Tool for Integrated Urban and Interurban Traffic Control: Evaluation in Corridor Peripherique, Paris," *Proc. Vehicle Navigation and Information Systems Conference*, Yokohama, Japan, 1994.

7. PARAMICS Model: 12 References (1994-1997)

- 7.94.01 Duncan, G.I., "PARAMICS-MP Final Report," Edinburgh Parallel Computing Centre, University of Edinburgh, 1994.
- 7.95.01 Duncan, G.I., "Paramics Wide Area Microscopic Simulation of ATT and Traffic Management," Proc. 28th ISATA Symposium, Stuttgart, Germany, 1995.
- 7.95.02 McArthur, D., "The PARAMICS-CM Behavioral Model," Proc. PTRC Annual Meeting, Seminar E, 1995.
- 7.95.03 Smith, M., G. Duncan and S. Druitt, "PARAMICS : Microscopic Traffic Simulation for Congestion Management," IEE Colloquium on Dynamic Control of Strategic Interurban Road Networks, London, England, 1995.
- 7.96.01 Cameron, G.D.B., and G.I. Duncan, "PARAMICS: Parallel Microscopic Simulation of Road Traffic," Journal of Supercomputing, Vol 10(1), 1996.
- 7.96.02 Duncan, G.I., "Simulation at the Microscopic Level," Traffic Technology International, Feb./Mar. 1996
- 7.96.03 Quadstone, Ltd, "PARAMICS:Wide-Area Microscopic Traffic Simulation. UK Motorway Validation Report," 1996.
- 7.97.01 Paramics Ltd, "PARAMICS Version 1.5," Vol 1: System Overview, Vol 2: Reference Manual, 1997.
- 7.97.02 Paramics Ltd, "PARAMICS: Car Following, Lane Changing and Junction Modeling," Report, 1997.
- 7.97.03 Paramics Ltd, "Comparison of PICADY and PARAMICS for Priority Junctions," Report, 1997.
- 7.97.04 Paramics Ltd, "Comparison of ARCADY and PARAMICS for Roundabout Flows," Report, 1997.
- 7.97.05 Paramics Ltd, "PARAMICS: Saturation Flows at Signals," Report, 1997.

8. SATURN Model: 31 References (1979-1996)

- 8.79.01 Bolland, J.D., M.D. Hall, and D. Van Vliet, "SATURN, a Model for the evaluation of Traffic Management Schemes," Working Paper 106, Institute of Transport Studies, University of Leeds, 1979.
- 8.80.01 Hall, M.D., D. Van Vliet, and L.G. Willumsen, "SATURN: A Simulation-Assignment Model for the Evaluation of Traffic Management Schemes," Traffic Engineering & Control, Vol 21(4), 1980.
- 8.81.01 Ferreira, L.J.A., " The Role of Comprehensive Traffic Management in Energy Conservation," Proc. PTRC Summer Annual Meeting, 1981.
- 8.82.01 Ferreira, L.J.A., M.D. Hall, and D. Van Vliet, " Applications of SATURN to the Analysis of Traffic Management Schemes," Proc. PTRC Summer Annual Meeting, 1982.
- 8.82.02 Van Vliet, D., "SATURN-A Modern Traffic Assignment Model," Traffic Engineering & Control, Vol 23(4), 1982.
- 8.83.01 Chorrafa, A., and L.J.A. Ferreira, "Using SATURN to Assess the Impacts of Traffic Management Schemes in Liverpool," Traffic Engineering & Control, Vol 24(1), 1983.
- 8.84.01 Luk, J.Y.K., and R.W. Stewart, "Some Experience with Three Urban Network Models: SATURN, TRANSYT/8, and NETSIM," Australian Road Research, Vol 14(2), 1984.
- 8.85.01 Carlisle, J.S., and R.T. Tudge, "SATURN, a Bright Star," Transport '85', Sydney, 1985.
- 8.86.01 James, M.L., and M.W. Davies, "SATURN Traffic Management Model Evaluation," Proc. 11th Australian Transport Research Forum, 1986.
- 8.86.02 Tudge, R.T., and J.S. Carlisle, "SATURN, a Case Study (Sydney Eastern Districts)," Proc. 13th Australian Road Research Board, pt. 8, 1986.
- 8.86.03 Van Vliet D. et al, "Equilibrium Traffic Assignment with Multiple User Classes," Proc. PTRC Summer Annual Meeting, 1986.
- 8.87.01 Matzoros, T., et al, "Validation of the SATURN and ME2 Models using Before-and-After Survey Data from Manchester," Traffic Engineering & Control, Vol 28(12), 1987.
- 8.89.01 Coombs, R.D., and S.C. Leigh, "A Modeling Exercise to Study Benefits from Urban Road Improvements," Contractor report 142, Transport Research Laboratory, 1989.
- 8.89.02 McSheen, J.R., R.C. Hale, "Traffic Modelling in Kuwait. 1: Development of a SATURN Network Database," Traffic Engineering & Control, Vol 30(10), 1989.
- 8.89.03 Hale, R.C., and J.R. McSheen, "Traffic Modelling in Kuwait. 2: Development of a multi-modal Traffic Model for the Kuwait metropolitan area," Traffic Engineering & Control, Vol 30(10), 1989.

- 8.90.01 Heydecker, **B.G. J.** Van Vuren, and D. Van Vliet, "Optimum Signal Offsets for Traffic Assignment Networks," Engineering Foundation Conference, 1990.
- 8.90.02 Johnson, K.R., and J.D. Hodson, "Development of a SATURN Network for the South Circular Assessment Study - a Two Tier Approach," Proc. PTRC Summer Annual Meeting, Seminar H, 1990.
- 8.90.03 Palgunadi, A., "An Application of SATURN to Analyze Traffic Problems in Jakarta," Proc. Road Engineering Association of Asia, Vol 3, Kuala Lumpur, 1990.
- 8.90.04 Van Vliet, D., "Fundamental Requirements for Full Scale Route Guidance--Recent Developments to SATURN," Memorandum, University of Leeds, 1990.
- 8.90.05 Van Vuren, T., M.J. Smith, and D. Van Vliet, "Mutually Consistent Signal Control and Traffic Assignment," Engineering Foundation Conference, 1990.
- 8.91.01 Black, D., and J. Arnold, "Weymouth Town Centre Traffic Study," Highways and Transportation, Vol 38(8), 1991.
- 8.91.02 Rogers, K., "Congested Assignment and Matrix Capping: Constraining the Trip Matrix to Reflect Network Capacity," Traffic Engineering & Control, Vol 32(7/8), 1991.
- 8.93.01 May, A.D., et al, "Application of SATURN in Bangkok," Traffic Engineering & Control, Vol 34(1), 1993.
- 8.93.02 Milne, D.S., A.D. May, and D. Van Vliet, "Modelling the Network Effects of Road User Charging: Results from a SATURN Study," Working paper 41 1, Institute for Transport Studies, University of Leeds, 1993.
- 8.93.03 Sharples, R., "Modeling Cyclists in SATURN," Traffic Engineering & Control, Vol. 34(10), 1993.
- 8.93.04 Tucker, G., L. Ferreira, "SATURN, an Application in Ipswich," Road & Transport Research, Vol 2(1), 1993.
- 8.93.05 Willumsen, L.G., et al, "Multi-Modal Modelling in Congested Networks: SATURN and SATCHMO," Traffic Engineering & Control, Vol 34(6), 1993.
- 8.94.01 Smith, M.J., et al, "A Comparison of the Network Effects of Four Road User Charging Systems," Traffic Engineering & Control, Vol 35(5), 1994.
- 8.94.02 Yanaguaya, W., "The Conversion of Standard Speed-Flow Curves into Flow-Delay Relationships for Use in SATURN," Traffic Engineering & Control, Vol 35(6), 1994.
- 8.95.01 Van Vliet, D., "SATURN-9.3 User's Manual," University of Leeds, 1995.
- 8.96.01 Rogers, K., "Matrix Capping, Update," Traffic Engineering & Control. Vol. 37(2), 1996.

9. TRANSIMS Model: 10 References (1994-1997)

- 9.94.01 Shunk, G.A., "TRANSIMS Project Description--Travel Model Improvement Program," Report, Texas Transportation Institute, August 1994.
- 9.95.01 Barrett, C., et al, "An Operational Description of TRANSIMS," Report LA-UR-95-2393, Los Alamos National Laboratory, 1995.
- 9.95.02 Morrison, J. and V. Loose, "TRANSIMS Model Design Criteria as Derived from Federal Legislation: Final Report," Los Alamos National Laboratory, 1995.
- 9.95.03 Schreckenberg, M., and K. Nagel, "Physical Modeling of Traffic with Stochastic Cellular Automata," Proc. 28th ISATA Symposium, Stuttgart, Germany, 1995.
- 9.95.04 Smith, L., et al, "Overview of TRANSIMS: The Transportation Analysis and Simulation System," Los Alamos National Laboratory, May 1995.
- 9.95.05 Smith, L., et al, "TRANSIMS: Transportation Analysis and Simulation System," Proc. National Conference on Transportation Planning Methods, Seattle, Wash, 1995.
- 9.95.06 Smith, L., et al, "TRANSIMS, Transportation Analysis and Simulation System," Los Alamos National Laboratory, 1995.
- 9.96.01 Nagel, K., "Particle Hopping Models and Traffic Flow Theory," Physical Review E, Vol 53(5), 1996.
- 9.96.02 Williams, M., et al, "TRANSIMS Environmental Module," Transportation Research Board A1 F03 Summer Conference, San Rafael, 1996.
- 9.97.01 "TRANSIMS," Session 359 (8 presentations), 76th TRB Annual Meeting, January 1997.

10 WATSIM Model: 5 References (1996-1997)

- 10.96.01 Lieberman, E.B., et al, "WATSIM: Wide-area Traffic Simulation Model for Freeways and Surface Streets," paper presented at the 75th TRB Annual Meeting, Washington DC, January 1996.
- 10.96.02 Yedlin, M., and E.B. Lieberman, "Recent and On-going Enhancements to TRAF-NETSIM," PATH Report 96-C12, University of California Berkeley, 1996.
- 10.97.01 Ivanovic, M., et al, "Assessing the Impacts of Signal Preemption and Coordination on LRT Operations Using Simulation," paper #970934, presented at the 76th TRB Annual Meeting, Washington DC, January 1997.
- 10.97.02 Massoumi, R., et al, "WATSim Micro-Simulation Software: Case Study of the I-780/I-680/I-80," Proc. ASCE Conference Traffic Congestion and Safety in the 21st Century, Chicago, 1997.
- 10.97.03 Skabardonis, A., P. Menaker and E.B. Lieberman, "ATMIS Transportation Modeling Environment," PATH Research Report UCB-ITS-PRR-97-24, University of California Berkeley, 1997.

APPENDIX B

FREEWAY CORRIDOR SIMULATION MODELS: LIST OF CONTACTS

1. CONTRAM

Nick B. Taylor
Transport Research Laboratory
Old Wokingham Rd
Crowthorne, Berkshire **RG45 6AU**
United Kingdom

Phone No: **011-44-1344-770643**
FAX No: **011-44-1344-770494**
e-mail: **nicholast@t.trl.co.uk**

Prof Mike McDonald
Transportation Research Group
University of Southampton
Southampton, **so 9 5NH**
England

Phone No: **011-44-703-592-192**
Fax No: **011-44-703-593-152**
e-mail: **mm7@soton.ac.uk**

2. CORFLO (and CORSIM)

Dr. Henry Lieu
Federal Highway Administration
Turner ~~Fairbanks~~ Research Center HSR-11
6300 Greorgetown Pike
McLean, **VI 22101**

Phone No: **(703) 285--2410**
FAX No: **(703) 285-2264**
e-mail: **henry.lieu@fhwa.dot.gov**

3. CORSIM

Larry Owen
Kaman Sciences Corporation
PO **Box 7463**
Colorado Springs, CO **80933-7463**

Phone No: **(719) 599-1170**
Fax No: **(719) 599-1387**
e-mail: **owen-cos1@kaman.com**

4. DYNASMART

Prof R. Jayakrishnan
Institute of Transportation Studies
University of California, Irvine
Irvine, CA **92717**

Phone No: **(714) 824-6663**
FAX No: **(714) 824-8385**
e-mail: **jaykay@translab.its.uci.edu**

Prof Hani S. Mahmassani
Department of Civil Engineering
Ernest Cockrell Jr. Hall, Suite 6.2
University of Texas at Austin
Austin, TX 78712-1076

Phone No: (512) 475-6361
Fax No: (512) 471-0592

e-mail: hani_mahmassani@cemailgate.ce.utexas.edu

5. INTEGRATION

Prof Michel Van Aerde
Department of Civil Engineering, Ellis Hall
Queens University
Kingston, Ontario
Canada, K7L 3N6

Phone No: (613) 545-6370
FAX No: (613) 545-2128
e-mail: vanaerde@civil.queensu.ca

6. METACOR/METANET

Prof Markos Papageorgiou
Dynamic Systems and Simulation Laboratory
Dept of Production Engng and Management
Technical University of Crete
GR-73100 Chania, Greece

Phone No: 011-30-821-69324
FAX No: 011-30-821-69568
e-mail: markos@dssl.tuc.gr

7. PARAMICS

Gordon Duncan, Technical Director
Paramics Traffic Simulation Ltd
16 Chester Street
Edinburgh, EH3 7RA
United Kingdom

Phone No: 011-44-131-220-4491
FAX No: 011-44-131-220-4492
e-mail: gordon@quadstone.co.uk

8. SATURN

Dr. Dirck Van Vliet
Institute of Transport Studies
University of Leeds
Leeds, LS2 9JT
England

Phone No: 011-44-113-233-5338
FAX No: 011-44-113-233-5334
e-mail: dvan@its.leeds.ac.uk

9. TRANSIMS

Dr. Richard Beckman
Los Alamos National Laboratory
PO Box 1663, MS :S600
Los Alamos, NM 87545

Phone No: (505) 667-1443
FAX No: (505) 667-4470
e-mail: rjb@lanl.gov

10. WATSIM

**Edward Lieberman
KLD Associates
300 Broadway
Huntington Station
New York, 11746**

**Phone No: (516) 549-9803
FAX No: (516) 351-7190
e-mail: klhunt@delphi.com**

APPENDIX C

EXPERIENCES WITH SIMULATION MODELS

IDENTIFICATION AND EXPERIENCES
WITH THE
CORFLO AND CORSIM SIMULATION MODELS

draft prepared by

Adolf D. May

May 1997

A part of a University of California PATH Study for the California Department of Transportation to identify and assess large-scale simulation models and the availability of their input data requirements. The Principal Investigator for this study is Dr. Alex Skabardonis.

T-A-R-L-E O-F C-O-N-T-E-N-T-S

1.	CORFLO AND CORSIM BIBLIOGRAPHY	-----	2
2.	CORFLO AND CORSIM LITERATURE DIGEST	-----	2
	2.1 Summary of CORFLO Applications	-----	3
	2.1.1 The NETFLO Model	-----	3
	2.1.2 The FREFLO Model	-----	3
	2.1.3 The CORFLO Model	-----	4
	2.2 Summary of CORSIM Applications	-----	6
	2.2.1 The NETSIM Model	-----	6
	2.2.2 The FRESIM Model	-----	6
	2.2.3 The CORSIM Model	-----	6
	2.2.4 The WATSIM Model	-----	7
3.	CORFLO AND CORSIM PHONE INTERVIEWS	-----	7
	3.1 California Experience	-----	7
	3.2 Georgia Experience	-----	8
	3.3 Nebraska Experience	-----	8
	3.4 Ohio Experience	-----	9
	3.5 Texas Experience	-----	9
	3.6 Virginia Experience	-----	10
	3.7 Washington Experience	-----	11
	3.8 Other Experiences	-----	11
4.	CORFLO AND CORSIM DOCUMENTATION	-----	12
	4.1 CORFLO Documentation	-----	13
	4.2 CORSIM Documentation	-----	14
	4.3 WATSIM Documentation	-----	1

IDENTIFICATION AND EXPERIENCES WITH THE CORSIM AND CORFLO MODELS

During 1997, the University of California at Berkeley (UCB) under sponsorship from the California Department of Transportation (CALTRANS) undertook a study to identify and assess large-scale simulation models and the availability of their input data requirements. The objective of the UCB study was to provide guidance to CALTRANS in regard to future applications of large-scale simulation models for comprehensive ITS investigations of extensive freeway corridors.

Previous experiences had alerted CALTRANS that large-scale simulation models were in their early years of development and that this class of simulation model required extensive input data sets. The guidance to be provided was whether the current development of these models and the current availability of input data was such to provide some assurance that near-term freeway corridor applications would be successful.

The scope of this report is limited to the identification and recording of experiences of the applications of the TRAF family of models with particular attention given to the CORFLO and CORSIM models. This portion of the larger study was undertaken in four sequential steps which are briefly described in the following four paragraphs.

The initial effort was directed to assembling as complete a bibliography as possible of references which dealt with any aspect in the development and application of the CORFLO and CORSIM models. The bibliography was organized into the following model classes: NETFLO, FREFLO, CORFLO, NETSIM, FRESIM, CORSIM, and WATSIM. The CORFLO model includes the NETFLO and FREFLO models, the CORSIM model includes the NETSIM and FRESIM models, and the WATSIM model is closely related to the CORSIM model.

The second part of the study was directed to the review of identified references dealing specifically with the application of the CORFLO and CORSIM models. A brief digest of each identified reference was prepared for these two models.

The third phase of this effort was to undertake an extensive set of phone interviews with individuals having application experience with the CORFLO and CORSIM models. The purpose of these phone interviews was to obtain direct personal application experiences with all individuals associated with these two models.

The fourth and last task was to review CORFLO and CORSIM model documentation in order to become aware of the evolution of these models and to become familiar with input data requirements,

model structure, and output reports.

1. CORFLO AND CORSIM BIBLIOGRAPHY

An extensive literature search was undertaken using the UCB/ITS information retrieval systems. Because of the comprehensiveness of the search, it is felt that over ninety percent (**90%**) of all CORFLO and CORSIM published documents were identified. NETSIM references prior to **1987** are not included but attempts have been made to include all references for all other TRAF models including the WATSIM model.

Illustration **1** provides a tabulation of all references identified by model and by year. A total of **156** references were identified with almost two-thirds of the references dealing with the NETSIM model. The bibliography included nine CORFLO references and six CORSIM references. It should be noted that except for the FREFLO and NETSIM models, all references were published within the last ten years.

The entire bibliography is contained in Appendix A and is organized by individual model and within each model listing, organized by year. No references were identified belonging specifically to the NETFLO model (Group **1**). Thirteen references were identified belonging to the FREFLO model (Group **2**) with the first reference appearing in **1971** and the most recent in **1994**. Note the coding system for the FREFLO model references in **1979**; **2.79.01**, **2.79.02**, etc. Nine CORFLO references were identified beginning in **1991** and continuing through **1996**.

NETSIM references were available as early as the late **1970's** but only references since **1987** are included in the bibliography. Ninety-three (**93**) references were identified with several appearing in the literature during early **1997**. FRESIM references as early as **1988** were identified with the most recent ones published in early **1997**. It should be noted that the earlier version of the FRESIM model was called the INTRAS model.

The CORSIM model search identified six references which were published between **1994** and early **1997**. Three WATSIM references were identified with two published in **1996** and the other in early **1997**.

During later stages of the study, other unpublished and/or internal documents were mentioned during the phone interviews.

2. CORFLO AND CORSIM LITERATURE DIGEST

With the completion of the literature search and the identification of published references, attention was directed to **digesting and summarizing the published experiences of the CORFLO**

and CORSIM model applications. Attention was first be given to the CORFLO model and then to the CORSIM model.

2.1 Summary of CORFLO Applications

The FHWA TRAF-FLO model family consists of the NETFLO model (for arterial networks), the FREFLO model (for freeways), and their integration into the CORFLO model (for freeway corridors). The purpose of this section is to provide preliminary information about the TRAF-FLO model family with particular emphasis on available application documentation.

2.1.1 The NETFLO Model

The NETFLO model is that portion of the CORFLO model which handles the arterial network portion of the freeway corridor. After a number of library searches, no references have been identified which directly pertain to the NETFLO model. Since NETFLO is a part of the CORFLO model, some information about the NETFLO model is available as the CORFLO model is described in a later section **of** this document.

2.1.2. The FREFLO Model

The initial versions of the FREFLO model preceded the concept and development of the FHWA TRAF-FLO family of models. Dr. Harold Payne developed the initial versions in the **1970's**. By the early 1980's the concept of the TRAF-FLO family of models began.

There are at least seven application studies described in eight publications which took place between 1982 and 1994. Each **of** these studies are described and associated references identified in the following seven paragraphs.

The FREFLO model was applied and modified in a research study at the University of California in 1982-1984 and is documented (2.84.01). The study was concerned with adaptive on-line freeway entry control. Some problems were encountered in the application of the FREFLO model when there were sudden increases **in** demands or decreases in capacities. However, the FREFLO model showed promise for further research.

Further work with the FREFLO model occurred in 1985-1987 and was undertaken by a group of investigators at KLD Associates. (2.87.01). Preliminary work with the model revealed difficulties in modeling oversaturated congested freeway flow. The FREFLO model was modified and further applications indicated that the model gave satisfactory results under moderate and severe congestion.

In 1992 a study was reported by AEPCO Inc. **of** an application of the FREFLO model to a section of **1-70** freeway in Columbus, **Ohio** (2.92.02) . The **FRESIM** model was also applied and

comparisons made between the two models. It was reported that FREFLO, with modest calibration effort, was judged as an excellent tool for general traffic operations analysis.

A study was reported in 1992 by JHK and Associates in which four freeway models were applied in five case studies and evaluated (2.92.04). The four models were the HCM HCS software, the FREQ model, and the FRESIM model, and the FREFLO model. (Need to add results).

The Texas Transportation Institute undertook freeway research in the early 1990's with reports published in 1992 (2.92.01) and (2.92.03). The study reported the use of the FREFLO model as a standard to be used in the development and evaluation of several entropy condition modifications which improved the modeling of congested freeway sections. Further research was anticipated but references of such further work have not been located.

A second study was undertaken at the Texas Transportation Institute with the FREFLO model in which a energy-based fuel consumption subroutine was added to the model (2-94-02). A comparison was made between the fuel predictions of the FREFLO and FRESIM (INTRAS) models when applied to 1-35 freeway near Austin, Texas.

A study was undertaken by the Virginia Transportation Research Council in the early 1990's and reported in January 1994 in which the FREFLO model was used in a HOV systems analysis investigation (2.94.01). Primary attention in the study was given to HOV systems analysis and little reference was given to the FREFLO model other than to report its application.

No references have been located which are associated with the FREFLO model since January 1994.

2.1.3 The CORFLO Model

The CORFLO model is a freeway corridor model which resulted from the integration of the NETFLO (arterial network) and FREFLO (freeway) models. The earliest concepts of a TRAF-FLO family of models appeared in the late 1970's and early 1980's. However, the first reference located which described the development and application of the CORFLO model was in 1991 (3.91.01). A TRAF-CORFLO training course was held in 1994 and a participant workbook became available (3.94.02).

This first reference on the development and the application of the CORFLO model reported the model capabilities to include: impact of incidents, reconstruction, bottlenecks, design alternatives, and control strategies in a highway network composed of freeways and surface streets (3.91.01). It was also reported that the CORFLO model had the capabilities to be used in planning

activities such as the assessment of network performance as a function of fluctuating origin-destination trips, regional control strategies, and traffic diversion strategies.

There were at least seven studies undertaken in which the CORFLO model was applied to actual freeway corridors during the early **1990's**. These seven studies are briefly described in the following seven paragraphs.

The Washington Department of Transportation evaluated the TRAF family of models with particular attention given to the CORFLO and FRESIM models (**3.92.01**). It was reported that the CORFLO model could not be adequately calibrated to represent existing traffic flow. There was also a concern about the extensiveness of input data requirements and the difficulty of obtaining it. It was suggested that the CORFLO program be modified **so** that it could run on personal computers. It was reported that McTrans has released a PC version in **1992**.

In another study, the CORFLO model was applied to a section of 1-70 freeway in Columbus, Ohio (**3.92.02**). The paper describes the model coding, validation, and application results. It would appear that the application might have been limited to a freeway only, and therefore perhaps only the FREFLO portion of the CORFLO model was utilized. Model shortcomings are identified, and enhancements to the CORFLO model described. Recommendations were made regarding future modeling efforts with CORFLO.

A research team at the University of Nebraska applied the CORFLO model to a freeway corridor on 1-80 and to an arterial street corridor in the Omaha-Council Bluffs metropolitan area (**3.94.03**). The objective of the study was to demonstrate and evaluate the use of CORFLO for evaluating traffic congestion management strategies. It was determined that the CORFLO model did provide a reasonable re-creation of existing traffic conditions. It was also found that CORFLO model is best suited to the simulation of traffic management strategies involving changes in roadway geometric and/or traffic control, but is not well suited to the simulation of travel demand management strategies.

The first of two studies undertaken at the Texas Transportation Institute with the CORFLO model was to evaluate traffic management alternatives for freeway incidents (**3.94.01**). A case study was presented to provide an understanding of the corridor-analysis process, to discuss the difficulties involved, and to suggest the necessary precautions to take in using a simulation model for studies of incident management strategies.

The second study at the Texas Transportation Institute was focused on the capabilities necessary to model urban public transit systems (**3.95.01**). A comparative evaluation **of** traffic simulation models was conducted but actual model testing was

limited to the CORFLO model. The study identified feasible enhancements to the CORFLO model but revising the model was beyond the scope of the study.

The next reported study with the CORFLO model was published in March 1995 (3.95.02) . The study was undertaken at Georgia Tech Research Institute and primarily dealt with the development of a ATMS Universal Traffic Operations Simulation (AUTOS). In the conduct of the research, a number of models were studied included the FRESIM, NETSIM, CORFLO, METS, and AUTOS models. The strengths and weaknesses of the various models are described. It does not appear that the CORFLO model was actually used.

The last reported study with the CORFLO model was published in August 1996 (3.96.01). The CORFLO model was applied to the SMART Corridor in the Los Angeles Metropolitan Area. The freeway corridor was a very extensive corridor and consisted of the Santa Monica Freeway and the adjoining arterial network. Considerable effort was expended on assembling the input data and calibrating the model. The level **of** application was somewhat limited due to the extensive data collection and calibration effort.

2.2 Summary of CORSIM Applications

The FHWA TRAF-SIM model family consists of the NETSIM model (for arterial networks), the FRESIM model (for freeways), and their integration into the CORSIM model (for freeway corridors). The purpose of this document is to provide preliminary information about the TRAF-SIM model family with particular emphasis **on** available documentation.

2.2.1 The NETSIM Model

The NETSIM references were not studied in detail because of the extensive number of references and because the focus of this study was directed to freeway corridor models; in this case to the CORSIM model. Key issues of the relationship of the NETSIM model to the CORSIM model are covered in the discussion **of** the CORSIM model.

2.2.2 The FRESIM Model

The FRESIM references were not studied in detail because of the extensive number of references and because the focus of this study was directed to freeway corridor models; in this case to the CORSIM model. Key issues of the relationship of the FRESIM model to the CORSIM model are covered in the discussion of the CORSIM model.

2.2.3 The CORSIM Model

(TO BE COMPLETED)

2.2.4 The WATSIM Model

(TO BE COMPLETED)

3. CORFLO AND CORSIM PHONE INTERVIEWS

The third phase of this effort was to conduct a series of phone interviews with users of the CORFLO and CORSIM models in order to obtain first-hand experiences with the model applications. The previous literature search and literature digest was the starting point for this effort.

A list of twenty-five individuals who had experiences with these models were selected for the phone interviews and an interview form was developed. The interview form provided space for verifying publications available, description of experiences, assessment of experiences, future use plans, final recommendations, and the identification of other model users.

This portion of the report is organized on a state-by-state basis. Within each state report a specific study is identified, the individuals selected for interviews identified, and a summary of experiences prepared. It should be noted that the interviewees have not the opportunity of reviewing this information but every effort has been taken to insure a faithful record of the information obtained in the phone interviews. The phone interviews with several individuals who had participated in the same study application provided means of checking and verifying information about a particular study application.

3.1 California Experience

The California experience was applying the CORFLO model to the SMART Corridor in Los Angeles. The individuals who were interviewed by phone included: Alan Clelland, Tom Gaul, David Roseman, Sun-Sun Tzedten, and Mike Wentland. The key reference is "Lessons learned from the Trial of the CORFLO Model" (3.96.01) published in 1996.

The first three individuals contacted were Alan Clelland and Mike Wentland, both of JHK Associates, and Tom Gaul of Kaku Associates. Alan Clelland was the Principal Investigator on the SMART Corridor project and he suggested that Tom Gaul and Mike Wentland were the users of the CORFLO model and should be interviewed. At the end of the project, the developed CORFLO application was turned over to the City of Los Angeles, and first, David Roseman was interviewed and in turn, Sun-Sun Tzedten.

The clients selected the CORFLO model and other models were not considered in this study. The freeway corridor to be studied was very extensive and the model arrays were modified in order to simulation such a large network. The need for traffic re-assignment interacting with traffic simulation was recognized from the very beginning of the project but unfortunately the traffic re-assignment portion of the model was never made operational and the reassignment was handled manually with great effort.

Primary effort was directed to assembling input data and calibration. After considerable effort the model was deemed to have been calibrated. Because of the traffic re-assignment limitations, the applications were limited. Several additional model features were found to be desirable such as an improved transfer of vehicles from one time period to the next, improved coding technique for traffic signals, and improved output.

At the conclusion of the study, the calibrated model was turned-over to the Los Angeles Department of Transportation (LA DOT). The JHK/Kaku team had no further plans using the CORFLO model and was not aware of any more recent work in the SMART Corridor with the CORFLO model or with other models.

David Roseman of the LA DOT was contacted and indicated that the calibrated CORFLO model had been turned over to LA DOT at the end of the study. He suggested that Sun-Sun Tzedten be contacted for more up-to-date information about the status of the CORFLO model. It was indicated that there was a concern about the quality of the calibration and after fourteen trials, a satisfactory calibration was not obtained; The predicted model delays far exceeded the actual field-observed delays. Other problems encountered included the modeling of incidents and the interface between the NETFLO and FREFLO models. There appeared to be no further plans at this time to use the CORFLO model in the SMART Corridor.

3.2 Georgia Experience

The Georgia experience with the CORFLO model was undertaken at Georgia Tech Research Institute in a study entitled "ATMS Universal Traffic Operations Simulation-AUTOS" (3.95.02). The article gave the impression that the primary goal was the development of the AUTOS model and other models such as CORFLO provided background information.

The principal author of this study was J. F. Gilmore. A phone interview with J. F. Gilmore was never completed after several unsuccessful attempts to find a way of reaching him.

3.3 Nebraska Experience

The Nebraska experience was applying the **CORFLO** model to

the 1-80 corridor in Omaha, Nebraska. The individuals who were interviewed by phone included: Jim Bonneson and Pat McCoy. The key reference is "Development of Corridor Models for Evaluating Traffic Management Strategies in the Omaha Metropolitan Area" (3.94.03) published in 1994.

A decision was made to use the CORFLO model without considering other possible models. The 1-80 corridor consisted of the freeway, two parallel arterials, and six interchanges and accompanying cross-arterials. Extensive data collection was undertaken and the model calibrated. The calibrated model was deemed adequate based on reviews by traffic experts with the City of Omaha, the State of Nebraska, and the University of Nebraska. The application of the model was part of the early deployment study for Omaha. In the process of applying the model, the size of the corridor exceeded the model limitations, and the model dimensions were increased. In the applications it was learned that changes in the physical network and traffic control were easier to model than changes in traffic demands.

The Nebraska experience appears to be one of the most successful applications of the CORFLO model. Since the completion of the initial study, two additional CORFLO applications have been undertaken in Omaha. The University of Nebraska continues to use the CORFLO model for freeway corridor investigations.

3.4 Ohio Experience

The Ohio experience was applying the CORFLO model to the 1-70 freeway in Columbus, Ohio. The individual who was interviewed by phone was Charles C. Liu. The key reference is "Macro versus Micro Freeway Simulation: A Case Study" (3.92.02) published in 1992.

Only the FREFLO portion of the CORFLO model and the FRESIM portion of the CORSIM model were applied to a portion of the 1-70 freeway. The data requirements were modest and the calibration was deemed satisfactory. The primary application was for the evaluation in geometric design and number of lanes. The study was deemed to be successful, and the FREFLO and FRESIM models are predicted to be used in the future.

It is interesting to note that Charles Liu taught FRESIM courses from 1993-1995 as part of the NHI program. He is obviously very knowledgeable about these freeway models.

3.5 Texas Experience

The Texas experience with the CORFLO model included an applications in Dallas, Texas of the North Dallas Central Expressway by the Texas Transportation Institute. The individuals who were interviewed by phone included: Jim Carvell, Ray Krammes,

and Kevin Tyer. There are two key references describing CORFLO applications: "Corridor Analysis Guidelines for Incident Management" (3.94.01) and "Urban Public Transit Systems Modeling Capabilities" (3-95-01).

The North Dallas Central Expressway corridor was about nine miles long and included eight or so parallel arterials and a significant number of cross-corridor arterials. The size of the network required the model dimensions to be expanded. The O-D table was obtained using the Transplan model and used as the demand input to the CORFLO model. Data requirements were significant and calibration difficult. The model applications were concerned with incidents and reconstruction activities. The quality of the results were marginal.

The North Dallas Central Expressway corridor was also used in the urban transit modeling effort. Similar to the earlier application, the data collection effort and the calibration effort was significant. It was estimated that the project funding was on the order of \$ **200K** and took two years to complete. The CORFLO program was converted from the mainframe version to the PC version to ease the efforts on the project. The NETFLO portion **of** the CORFLO model was more difficult to code and some difficulty was encountered in conducting strategy investigations. It was felt that the major contribution of the study was the identification of desired improvements although project time and resources were not available to actually development these improvements.

The CORFLO program and associated input files were turned over to the TTI group in Dallas for the North Dallas Central Expressway but after several phone calls, there was no information available as to whether the CORFLO model was being used further or not.

It was not clear from the literature or phone interviews as to other applications of the CORFLO model in Texas. Indirectly it was understood that there had possibly been a CORFLO application in Houston on U.S. 59. It was also suggested that the CORFLO model might currently be used in San Antonio but this was not confirmed.

3.6 Virginia Experience

The Virginia experience was applying the CORSIM model to the 1-66 Freeway corridor in northern Virginia. The individuals who were interviewed by phone included: Mike Demetsky and Katherine McGhee both of the Virginia Transportation Research Council. The key reference is "Simulation Analysis of Route Diversion Strategies for Freeway Incident Management" (6.95.02).

A PC version of the CORSIM model was used. Apparently the data collection and calibration efforts were successful. The integration of the NETSIM and FRESIM models appeared to work in a

satisfactory manner. Some difficulties were encountered during model applications. These problems dealt with the automatic traffic assignment portion of the CORSIM model not working and manual traffic assignment being required, and with the inability of modeling HOV operations.

The FRESIM model is being applied in a new study in the Hampton Roads area. It is felt that the CORSIM model has a significant role to play in future applications.

3.7 Washington Experience

The Washington experience was applying the CORFLO model to the 1-405 freeway corridor in Seattle, Washington. The individual who was interviewed by phone was Eldon Jacobson of the Washington Department of Transportation. The key reference is "Evaluation of the TRAF Family of Models: Testing of the CORFLO and FRESIM Models" (3.92.01) .

After considerable effort had been expended to calibrate the CORFLO model, the project activities were terminated. There was also the concern raised as to the extensiveness of input data. In fairness to the model, the version of the CORFLO model was one of the earliest ones available and had not been converted to the PC at the time of the application.

There was no further report of activities with either the CORFLO nor CORSIM model since 1992.

3.8 Other Experiences

Two individuals were interviewed by phone without prior knowledge if they had applied the CORFLO or CORSIM model or if they had only been involved in the development of the model. These two individuals were Ammar Kanaan (current at DeLeuw-Cather) and Salameh Nsour (currently at Santa Clara University). During the phone interviews it was learned that they had both participated in the development of the CORFLO model, and that Ammar Kanaan had also participated in the development of the CORSIM model.

From approximately 1986 through 1996 Ammar Kanaan was attached to the Fairbanks Research Laboratories of FHWA. He participated in the updating of the FREFLO model and its conversion for PC use. A little later, he played a significant role in improving and connecting the NETSIM and FRESIM models for CORSIM applications. However, during the phone interview it was learned that he had not applied either the CORFLO nor CORSIM models in real-life applications. He was a co-author on two referenced papers "CORFLO, An Integrated Traffic Simulation System for Corridors" (3.91.01) and "Evaluation of Freeway Improvements Alternatives Using CORFLO" (3.92.02).

During the summer of 1993, Salameh Nsour worked at the Fairbanks Research Laboratories of FHWA and worked on the CORSIM model. This effort resulted in the paper "Comprehensive Plan Development for Testing, Calibration, and Validation of CORSIM" (6.94.01). His work centered on developing general guidelines for calibration and did not include model applications. He has not been involved with the CORSIM model since 1993.

4. CORFLO AND CORSIM DOCUMENTATION

The CORFLO and CORSIM documentation is being reviewed for two purposes. A review of the documentation will provide insights into the evolution of the models and the direction of model improvements. The second reason is to become familiar with the input data requirements, model structure, and output reports. The CORFLO, CORSIM, and WATSIM model documentation are discussed in the following three subsections.

4.1 CORFLO Model Documentation

The first paper describing the CORFLO model was presented in 1991 (3.91.01). The first CORFLO model training materials was published in 1994 (3.94.02). An informative documentation prepared by the Viggen Corporation for the CORFLO model became available in 1996 which provided an overview of the model. This portion of this paper is based on this latest 1996 documentation of the CORFLO model and the following outline is similar to the one given in the Viggen Corporation documentation.

4.1.1 TRAF Components

The simulation models of TRAF are: ROADSIM, NETSIM, FREFLO, NETFLO1, NETFLO2, AND FRESIM. The CORSIM model is expected to be included and distributed as part of the TRAF model in 1997.

4.1.2 Input Requirements

The analysis time period is divided into equal-length time periods, and traffic demands, control, and network features are inputted for each time period. These inputs are entered for each time period and may vary between time periods. Upto nineteen (19) time periods may be entered and the length of the time periods for a particular analysis time period may vary.

The input for each time period is divided into blocks, and in turn each block is divided into sections. Some sections define conditions on particular subnetworks while additional sections provide inputs for those specifications which are "global".

Within each section, the input stream consist of a sequence of "record types" or "card types". Each record type

contains a specific set of data items. These records within a section are assembled into groups.

Diagnostic tests are included within the program to provide warning messages when necessary, and if fatal, termination messages are provided.

4.1.3 Component Model Integration

In a multiple model network, each of the component models of CORFLO simulates a different subnetwork. The interfacing of adjoining subnetworks is accomplished by defining "interface nodes". These interface nodes represent points at which vehicles leave one subnetwork and enter another. Exit interface links into the interface models are provided for traffic exiting one subnetwork and entering interface links from interface nodes are provided for traffic entering another subnetwork. Associated with each interface node is a "vehicle holding area where exiting vehicles are held until the next subnetwork can take them.

A subnetwork is brought into central computer memory and simulated once over each time interval. All vehicle movements are simulated over the course of the time interval. At the end of a time interval, all information pertaining to the subnetwork is stored on a peripheral unit and the subnetwork is removed from memory. The next subnetwork is then brought in and simulated over the same time interval. Each subnetwork in turn is simulated over the course of the time interval. The process is then repeated for the next time interval until the analysis period has been completed.

During the course of each time interval, subnetworks are always processed in the same sequence. The sequence for the CORFLO model is as follows: FREFLO, NETFLO1, and NETFLO2. One subnetwork is specified for each simulation model in TRAF. NETFLO1, NETFLO2, and FREFLO subnetworks can be described in one run under CORFLO.

4.1.4 FREFLO Component Model

The FREFLO model **is** a macroscopic simulation model which represents traffic in terms of aggregate measures on each section of freeway. The aggregate measures used are flow rate, density, and space-mean-speed within each section.

The FREFLO model has been extending in two significant ways. First, freeway analysis can be performed on directional freeway segments but also on freeway networks which are either connected or not connected. Second, Buses, carpools, autos and trucks are distinguished as three distinct vehicle types.

There are two types of freeway lanes which can be modeled with FREFLO: special purpose HOV lanes and regular lanes. Vehicles

are not associated with individual lanes but are considered to be uniformly distributed over lanes.

Special features have been added so that buses are treated individually. Turn percentages, applicable to traffic exiting each section, apply to all vehicle types. However use of special lanes are taken into account. Incident situations can also be modeled.

4.1.5 NETFLO 1 Simulation Model

NETFLO1 is an event based simulation and each vehicle on the arterial network is handled as an identifiable entity. A vehicle can be identified as a auto, carpool, truck, or bus, and driver behavioral characteristics is assigned to each vehicle (passive, aggressive). The vehicles progress through the arterial network is handled stochastically.

While this treatment appears comparable to NETSIM, the most important difference is the level of detail of individual vehicle movements. While NETSIM moves each vehicle each second, NETFLO1 only moves vehicles when an event occurs. No car following logic is employed and NETFLO1 does not provide vehicle trajectories.

4.1.6 NETFLO 2 Simulation Model

NETFLO2 was adapted from the TRANSYT model. Inputs were simplified and the ability to handle time varying traffic flow and multiple cycle lengths were added. Histograms similar to those developed within the TRANSYT model are generated to represent flow of traffic on each link for each time interval.

Buses are treated as separate entities, however the treatment of buses is at a lower level than NETFLO2. While the interaction of buses with general traffic is explicitly treated, carpools are not modeled. Traffic congestion is treated explicitly, along with blockage due to spillback.

4.1.7 NETFLO Capacity Program

A NETFLO capacity program has been developed as a support program to NETFLO simulation program. The NETFLO capacity program calculates approach capacities in terms of movement specific service rates for use by the traffic assignment program. Data for the capacity program is coded by the user. It is reported that all types of intersection control devices can be handled.

4.1.8 Traffic Assignment Program

A traffic assignment program has been developed as a support program to the CORFLO model. The traffic assignment model

uses conventional traffic assignment techniques with user equilibrium and system optimization capabilities.

It is assumed that an external O-D table for the study area is available for each time interval. For this information to be useful as input to a simulation program, it must first be transformed into link-specific turning percentages. The mechanism for performing this transformation is the traffic assignment model.

The interfacing logic reads, checks, and performs all necessary data organization to provide the traffic assignment program with its data requirements. It then creates turn percentages and entry volumes for input into one or more of the specified component simulation programs.

4.1.9 TRAF Data Structure

The characteristics which vary **over** space include the traffic geometry such as number of lanes, turning pockets, etc; the types of links, such as surface street or freeway, and some elements of traffic behavior, such as gap acceptance. Characteristics which vary over time include traffic volumes, turn movements, traffic regulations, and signal timing.

The input stream begins with a set of data providing a basic description of the run being made (run control data). This is followed by a set of data divided into time periods, each of which has model-specific data for each kind of traffic network being simulated (models data). Each set of data is broken into a series of eighty column records. The first time period is unique in that it contains the data which does not vary from time period to time period. At the end of the mode data for the first time period is global network data which is applied to all sub-network data. This data describes traffic assignment (O-D data) and bus operations.

This data must include a description of the links, the traffic volumes, and the network controls. The data is structured **so** that many types of data records can be used in more than one model. At the end of each model's data for a time period is a subnetwork delimiter. Traffic assignment and bus data may be added at the end of the model data for time period **1**. If that model's data is the last data for that time period, then a time period delimiter is added. **If** that model's data is not the last set, the "170" delimiter tells CORFLO what model's data will be next. If the model's data is the last set for that period, the time period delimiter tells CORFLO to stop processing data for that time period and to begin processing data for the next time period.

After the last model in each time period, Record Type 210 is required. This data block indicates the end of the time period and whether an additional time period **follows**. Each model is coded

as a sub-network of the entire network being simulated. The subnetwork does not have to be in one piece. That **is**, a freeway might be coded in FREFLO. One side for the freeway might be coded in NETFLO1 while the other side could be coded in both NETFLO1 and NETFLO2. While the NETFLO1 subnetwork may not be geographically continuous, the data records for the subnetwork appear in the data stream as one unit for each time period.

Some of the most common record types of CORFLO are listed below.

- Run Control Records (Types 00-05)
- Urban Geometric Records (Type 11)
- Freeway Geometric Records (Type 15)
- Traffic Volume Records (Types 21, 50, and 51)
- Freeway Turn Movements (Type 26)
- Freeway Incident Records (Type 27)
- Freeway Parameters (Type 34)
- Sign or Pretimed Signal Control Records (Types 35 and 36)
- Actuated Control Records (Types 39, 40, and 41)
- Bus Operations Records (Types 150, 185-189)
- Traffic Assignment Records (Types 175-177)
- Graphic Records (Types 195 and 196)
- Delimiter Records (Types 170 and 210)

4.2 CORSIM Model Documentation

The first paper describing the CORSIM model was prepared in 1994 (6.94.01). The first CORSIM model user manual was published in 1995 (9.95.01). An updated CORSIM model user manual is expected to be available in mid-1997.

(add more information)

4.3 WATSIM Model Documentation

The first paper describing the WATSIM model was published in 1996 (7.96.01). KLD provided this study with a copy **of** a 1997 document entitled "Wide Area Traffic Simulation (WATSim). WATSim is a microscopic model and is a KLD proprietary software package. This portion of this paper is based on this latest 1997 documentation of the WATSIM model and the following outline is similar to the one given in the KLD report.

4.3.1 WATSim Overview

The intent of the WATSim model is to model any configuration of freeways, ramps, interchanges, and surface streets within this single model. The model distinguishes between freeway and surface street links and automatically applies appropriate logic to each environment. Recent developments have given special

attention to toll plazas and light rail transit.

4.3.2 WATSim Operating Characteristics

WATSim is a time-scanning discrete-event traffic simulation model. Each vehicle in the traffic stream is represented individually. Each vehicle in the traffic stream are assigned driver behavioral and vehicle performance characteristics. Upto sixteen **(16)** vehicle types can be specified by the user, and car-pool vehicles and buses can be assigned to specific lanes.

4.3.3 Model Outputs

A wide variety of performance measures can be obtained from the output including speed, volume, delay, spillback, and queues. Fuel consumption and pollutant emission measures are also provided. These performance measures are available for each network link, each intersection, groups of links and the entire network over user-specified time intervals.

4.3.4 WATSim Animation Displays

An affiliated interactive computer graphics program provides an on-screen 2-D animated display of simulated traffic operations which displays individual vehicle movements. Any animation display frame can be printed and included within reports. Options are available for 3-D animation at varying levels of realism and background detail.

4.3.5 WATSim Applications

WATSim is reported to have been extensively and successfully used in projects across the United States. These reported applications include ITS studies, toll plaza studies, HOV evaluations, light rail/signal preemption, arterial control, and geometric design. Only one or two applications were found in the literature search but perhaps due to these additional applications being very recent.

4.3.6 WATSim Architecture

One of the unique features of the WATSim model is its architecture. The WATSim architecture uses "structured programming" principals in which the software is comprised of many modules but each having a functional "cohesion". Hence these modules can be accessed frequently from different modules.

Other architecture features include the following attributes:

- A unified database designed around "relational" principles

- Consistent procedures representing driver behavior across all network elements.
- "Data hiding" techniques are employed **so** that extensions can be made either in terms of new model features or by interfacing with other programs.
- The structured design permits features in support of simulation to be treated as separate functions such as traffic assignment and signal optimization.
- The model supports the concept of **"packaging"** separate programs in concert without requiring user intervention.

4.3.7 WATSim Extensions

There have been a number of extensions to WATSim including toll plaza simulation and LRT operations with signal preemption. The toll plaza extension will handle the simulation of traffic within the approach to the plaza, within the plaza on the approaches to the toll booths, within the plaza downstream of the toll booths, and on the exiting roadways. The LRT operations with signal preemption permitted the inclusion of the simulation of rail vehicles and their behavior, and the effect of signal preemption.

4.3.8 Packaging WATSim with Other Programs

Interfacing with other software programs is possible such as with HCM/Cinema, SIG/Cinema, signal optimization, a representation of HCM Chapter 9 procedures, and GTRAF. This ability to package WATSim with other programs has been exploited in other directions as will be discussed in the next two subsections.

4.3.9 Traffic Assignment Models

A WATSim information system (WIS) has been developed that can package the WATSim simulation model with other independent software products such as with traffic assignment models. A simulation-assignment interface is available within WIS which provides a sequencing of simulation and assignment in an iterative fashion. This sequential interactive process includes the following steps:

- The simulation model is executed with observed **or** projected volumes and turn movements to calculate link travel times.
The selected traffic assignment model is then executed using a specified O-D table (or one generated within WATSim) and the link travel times to calculate the "optimal paths" for each O-D pair.
- These optimal paths are then processed to yield "path matrix" for all vehicles.
- Each cell of the O-D matrix provides turning movement information from which turning percentages

- can be obtained which define the next stage on the vehicle's path of travel.
- The link-specified travel times are updated by WATSim during each subsequent time period, while processing the movement of vehicles traveling over the network.
 - At the end of each time period, the traffic assignment model recomputes the optimal paths for each O-D pair, based on the most recent estimates of link travel time.
 - In this recursive manner the interfaced WATSim-traffic assignment system represents the changing traffic environment over the course of the analysis period.

4.3.8 Control Systems

An interface has been established between WATSim and the Arterial Analysis Program (AAP) which consists of PASSERII-90 and TRANSYT-7F. Both of these signal programs can optimize signal settings, and one or the other or both of these signal optimization programs can be called to optimize the signal settings.

4.3.9 Current Developments

KLD is undertaking a number of improvements/extensions to the WIS. These include will permit users to create their own reports in formats that are best suitable for them, application for the AAP program to work toward improved signal optimization, and development of techniques for improved signal phase sequences.

4.3.10 Comparison with CORSIM, NETSIM, and INTEGRATION

The developers of WATSim have offered a number of comparisons between the WATSim model and the NETSIM, CORSIM, and INTEGRATION models. It is suggested that the developers of the WATSim model have made a number of improvements in the NETSIM model dealing with car-following and lane changing, and have generalized them for all elements **of** the integrated network. In comparisons with the CORSIM model, it is suggested that there is greater commonality between the arterial and freeway portions of the model, and the interface between the two portions are handled in an improved manner. In comparisons with the INTEGRATION model, it is suggested that greater flexibility is provided by permitting external programs since as traffic assignment and signal optimization being incorporated into the WATSim/WIS model.

APPENDIX D

DATA FOR TRANSPORTATION MODELING IN THE SANTA MONICA CORRIDOR

**DATA FOR TRANSPORTATION MODELING IN
THE SANTA MONICA CORRIDOR**

Final Report

A Study Conducted Under MOU 269
In Support of MOU 270

Joy Dahlgren
California PATH
Institute of Transportation **Studies**
University of California
Berkeley

December 9, 1997

DATA FOR TRANSPORTATION MODELING IN THE SANTA MONICA CORRIDOR

Final Report

Introduction

Both Caltrans and the city of Los Angeles have been interested in establishing a simulation testbed for evaluating and optimizing alternative traffic management strategies before they are tested or implemented in the Santa Monica corridor (Figure 1). The feasibility and cost-effectiveness of establishing such a test bed depends on the availability of a suitable simulation model and sufficient accurate data on which to base the simulation. This report describes the data currently available and notes unmet data needs and potential methods of meeting them. The first section contains an assessment of the data needed and currently available. The second section contains a work plan for acquiring the necessary data along with estimated costs for data collection. There is also an appendix containing a decision analysis regarding the value of the simulation test bed, which shows the circumstances under which simulation is valuable

Assessment of Data

Data from the Previous Simulation

Some of the data for simulating the Santa Monica corridor have already been assembled for a simulation attempted by the Los Angeles Department of Transportation (LADOT) in 1996 using the CORFLO model developed for the Federal Highway Administration (FHWA). That attempt was abandoned when repeated re-calibration failed to yield the required level of accuracy. The following data have been collected and formatted as input to CORFLO:

- ❑ urban link characteristics
- ❑ freeway link characteristics
- ❑ urban street turning movements
- ❑ freeway turn movements (apply to traffic exiting each section)
- ❑ signal control
- ❑ entry link volumes
- ❑ source/sink volumes
- ❑ node coordinates for graphics

A new simulation effort could use the same supply data—road and street characteristics. However, the previous simulation covered only the PM peak period, so new signal timing, turning movement, and volume data would be needed. Furthermore, signal timing, turning

movements and volumes in the PM period may have changed since the previous simulation and should be checked and updated if necessary.

Data Needs and Availability

Table 1 summarizes the data requirements and the data available. The data expected to be required for whatever model is selected are shown on the left; the availability and other relevant characteristics are shown to the right. The Source column indicates the agency and contact person. The Source Document Number refers to the number written on the sample data collected by PATH. The availability of each data item is discussed in greater detail below.

Freeway Mainline Segment Lengths and Number of Lanes

These have already been coded for the previous simulation.

Effort required: Check for changes and modify if necessary. Few changes expected.

Ramp Lengths and Number of Lanes

These have already been coded for the previous simulation.

Effort required: Check for changes and modify if necessary. Few changes expected.

Ramp Metering Rates

PM peak period rates have already been coded for the previous simulation. AM and midday metering rates are still needed.

Effort required: Check for changes in PM rates and modify if necessary. Some changes expected. Gather AM and midday rates for approximately 25 on-ramps.

Ramp Meter Queue Overrides

An override occurs when the queue waiting to enter the freeway backs up into the city streets. Therefore, although it is a control strategy, its use is dependent on demand.

There are automatically controlled queue overrides on all freeway on-ramps, more than 25 on freeway and connector roads in the portion of the corridor to be modeled. When a queue backs up to the first queue-sensing loop, the metering rate is increased. When the queue backs up the second queue-sensing loop, the meter turns green until the queue is cleared. This is done automatically and no record is kept of how often it occurs. If this aspect of the ramp metering strategy is not taken into account, the simulation will underestimate the amount of traffic on the freeway and overestimate the traffic on the adjacent arterials. This was, in fact, one of the problems with the CORFLO simulation.

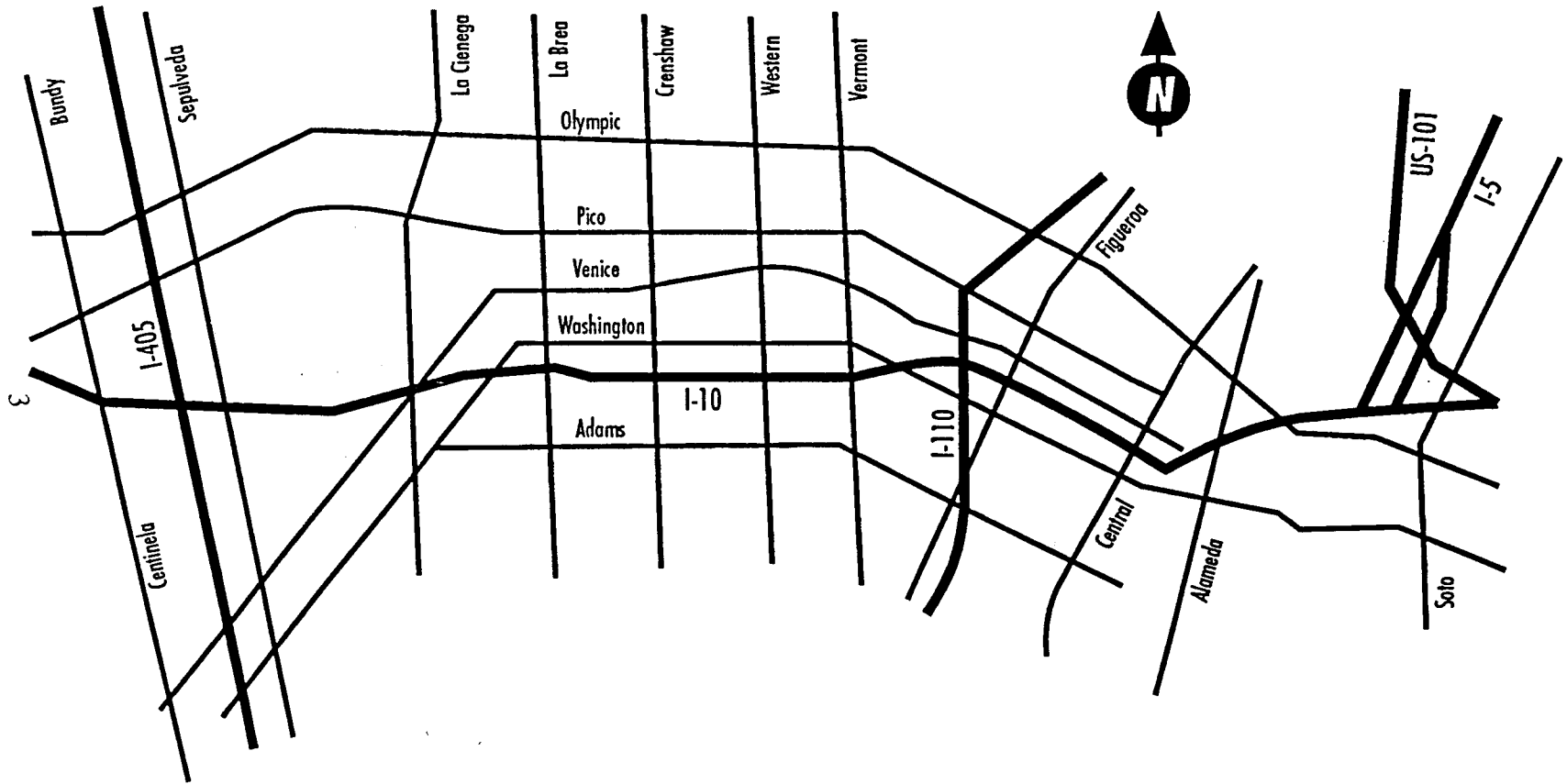

Figure 1: Smart Corridor Region

Table 1

DATA FOR MODELING THE SANTA MONICA CORRIDOR

Data Item	Complete Over Space	Complete Over Time	Quality	Ease of Access	Ease of Use	Knowledge of Provider	Cooperation Interest	Current?	Source	Source Document Number
Supply										
Freeway mainline segment length and lanes	yes	na	good	in hand	easy	good	good	yes	Caltrans/Kalbasi	1
Ramp lengths and number of lanes	on ramps only	na	good	in hand	fair	good	fair	1994	LADOT/KAKU	2
Ramp metering rates	yes	yes	good	good	easy	good	good	yes	Caltrans/ Abaza	3
Records of meter rate overrides	not available									
Arterial lengths	yes	na	good	in hand	easy	good	good	1994	LADOT/KAKU	2
Arterial number of lanes midblock	yes	na	good	in hand	easy	good	fair	1994	LADOT/KAKU	
Arterial lanes at intersection	yes	na	good	good	easy	good	good	yes	LADOT/Gallagher	2
Arterial lane turning restrictions	yes	na	good	good	easy	good	good	yes	LADOT/Gallagher	
Parking restrictions	yes	yes	good	in hand	easy	good	good	1994	LADOT/KAKU	2
Signal timing plans	yes	yes	good	good	difficult	good	good	yes	LADOT/Tvedten	4
Demand										
Freeway mainline volumes	yes	yes	75% of loops OK	fair	fair	good	good	yes	Caltrans/Kalbasi	5
Freeway ramp volumes	yes	yes	unknown	fair	fair	good	good	yes	Caltrans/Kalbasi	
Freeway travel times	not available									
Freeway incidents	yes	yes	good	fair	difficult	good	good	yes	CHP/Diebold	6
Arterial volumes	major arterial	15 min, all day	good	fair	difficult	good	good	yes	LADOT/Tvedten	
Arterial turning movements	major intersections	peak hour only	fair	in hand	difficult	good	good	1988-96	LADOT/Tvedten	7
Arterial travel times	yes	4:30-6:30	good	good	easy	good	good	1995	LADOT/Tvedten	
Delay at intersection approaches	yes	yes	good	difficult	difficult	good	good	yes	LADOT/Gallagher	7
Arterial incidents	yes	yes	good	difficult	difficult	good	good	yes	LADOT/Tvedten	
Origin-destination data	census tracts	yes	fair	fair	fair	fair	good	1991	SCAG/Minjares	

Sources:

1. Caltrans schematic of freeway and ramps labeled 07-LA-10-R6.00/14.0 from Kalbesi at Caltrans
2. Smart Corridor Operations Planning Element, Issue Paper on Existing Traffic Conditions, Draft, March 1994, Prepared by KAKU Associates for JHK & Associates from Tvedten at LADOT
3. Time of Day Table from Caltrans TMC from Abaza at Caltrans
4. Untitled handwritten worksheets from Tvedten at LADOT
5. Smart Corridor Main Line Loop Status from Kalbesi at Caltrans
6. Record Type 21 - Turning Movements and attached data printouts from Tvedten at LADOT
7. Actual Travel times used in calibration runs

The best way to model the queue override would be to build the queue override logic into the model. This would involve significant programming effort to modify the model and would require gathering data on the vehicle storage capacities downstream from the queue-sensing loop detectors. However, it would realistically model the effects of changes in demand at the ramps. An alternate approach would be to alter the nominal metering rate to account for the queue overrides; the metering rate would be demand dependent. This would require observation of each on-ramp during the congested period to determine the frequency with which overrides occur. The frequency would depend both on the average volume and the variation in volume. Either way, significant effort would be required. However, not making the effort would seriously compromise the results of the simulation.

Effort required: Programming the queue override logic would require determining the vehicle storage capacity downstream from both queue-detecting loops at over 25 on-ramps. Caltrans has the locations of all detectors in an on-line system. (Mohammed Kalbasi can describe how to access these.)

Arterial Lengths

These have already been coded for the previous simulation.

Effort required: Check for changes and modify if necessary. No changes expected.

Arterial Number of Lanes at Mid-block

These have already been coded for the previous simulation.

Effort required: Check for changes and modify if necessary. No changes expected.

Arterial Number of Lanes at Intersections

Diagrams of major intersections are available from Brian Gallagher of the LADOT.

Effort required: Record number of lanes at approximately 4 approaches to approximately 400 intersections.

Arterial Lane Turning Restrictions

PM peak restrictions were collected for the previous simulation.

Effort required: Check for changes in PM peak restrictions, and modify if necessary. Few changes expected. Record AM and midday restrictions at approximately 4 approaches to approximately 400 intersections.

Arterial Parking Restrictions

Restrictions for all times of day were collected for the previous simulation.

Effort required: Check for changes in restrictions and modify if necessary. Few changes expected.

Arterial Signal Timing Plans

Plans for the PM peak restrictions were collected for the previous simulation.

Effort required: Check for changes in PM peak plans, and modify if necessary. Some changes expected. Record AM and midday restrictions on over 100 arterial links.

Freeway Mainline Volumes

Although volume data was collected for the earlier simulation, it is likely that travel patterns have changes because of the Northridge earthquake and cutbacks in the defense industry, rendering this data obsolete. Loop detectors measure every link and lane of the mainline and the connector roads. However, the detectors are not always functioning properly. Caltrans has been monitoring these detectors for the Smart Corridor Project. In January about 75% of the detectors were functioning properly. Getting complete and accurate counts will require additional detector repair and maintenance on Caltrans' part. Because the computer used to store and transmit the data is slow, some of this data that has been sent to PATH for the Freeway Service Patrol project has been corrupted. Caltrans' staff has been investigating better methods for transmitting the data, including purchasing a faster computer, putting the data on a web site, or sending data tapes. The first option is the least expensive (an estimated \$3,000).

Effort required: Monitor mainline loop detectors and repair as required. Improve data transfer method. Aggregate and average volume data for each time period.

Freeway Ramp Volumes

The accuracy of the ramp detectors is not being monitored, so it would be difficult to determine if the counts are accurate. Checking the accuracy of the approximately 80 detectors necessary to determine volumes entering and exiting the freeway and connector roads would require calling up each loop to determine if it is working. The problems with transmitting the data are the same as for the mainline counts.

Effort required: Monitor mainline **loop** detectors and repair as required. Improve data transfer method. Aggregate and average volume data for each time period.

Freeway Travel Times

There is no freeway travel time information.

Effort required: Measure travel times over the course of the day using at least 3 cars with tachographic instruments. Aggregate and average the volume data for each time period.

Freeway Incidents

The highway patrol has logs from its computer aided dispatch (CAD) system which give date, time of day the call was received, location, the nature of the problem, and the time the CHP left the incident site. Because the logs cover a much wider area than is being studied and include many more things than incident information, extracting the relevant information will be time-consuming.

Effort required: Obtain and decode CAD logs. Record information relevant to incidents on the study section of the Santa Monica freeway.

Arterial Volumes

Because volume data are used for on-going operations of the LADOT, the loop detectors are likely to be providing relatively accurate volumes.

Effort required: Aggregate and average loop data for each time period for over 100 links.

Arterial Turning Movements

Turning movements used in the previous simulation were based on manual counts between 1988 and 1996 and include only the PM peak period. An accurate simulation would require data for the AM and midday as well and more current PM counts.

Effort required: Perform manual counts for at least one day at over 110 intersections. Average counts for each time period.

Arterial Travel Times

Travel times between 4:30 and 6:30 PM were collected in 1995 for use in calibrating the CORFLO model. However, this information may be out of date, and there is no information on travel times at other times of day.

Effort required: Measure travel times over the course of the day on the five east-west arterials and on four north-south arterials for at least one day using cars with tachographic equipment.

Delay at Intersection Approaches

At major intersections there are detectors which give seconds of delay per vehicle in real time, every 30 seconds. The data are not archived.

Effort required: Measurement of intersection delay would require capturing and aggregating the 30 delay information from the detectors at over 100 intersections with approximately 4 approaches each. Estimating travel times from tachographic car runs would probably be more accurate and less costly.

Arterial Incidents

The LADOT is developing an incident detection model and is keeping good records of incidents in order to tune the model. The records are kept for 4 months and include date, time the incident starts, time cleared, location, description of the incident, and action taken.

Effort required: Characterizing the incident data for use in the model.

Origin-destination Data

In 1991, the Southern California Association of Governments conducted an origin-destination survey to gain information for promoting ridesharing. It included 15,000 households in Los Angeles, San Bernardino, and Riverside Counties. People kept one-day diaries of all trips made by members of the households. Origins and destinations are at the census tract level. There are three problems with the use of the results of the study for the Santa Monica corridor. First, travel patterns may have changed since 1991. Second, because of the wide variety of routes available in Los Angeles, it would be difficult to determine which trips were made through the Santa Monica corridor. Finally, the sampling rate may not have been sufficient to provide reliable estimates for a relatively small area, such as the Santa Monica corridor. A similar study is currently underway, but SCAG staff do not think it would be as useful as the 1991 survey because it is less detailed. The 1991 survey is available from SCAG; Peter Wong of Caltrans also has the survey data.

A license plate surveys typically cost up to \$15 per survey response.

Effort required: Design survey instrument. Arrange for license plan survey. Process results.

Work Plan for Acquiring Data

Most of the supply data has been coded as input for the CORFLO model, but some items will require updating. Additional ramp metering rates and signal timing plans will be required to simulate the AM peak and midday traffic because the previous simulation included only the PM peak hour.

Obtaining demand data will be more difficult and expensive. Caltrans District 7 staff believe that travel patterns and volumes have changed because of the reduction in defense work. Therefore, data from the previous simulation may no longer be accurate. Even if it should prove to be accurate, it covers only the evening peak period, so additional data will be needed for AM peak period and midday. Most data are available. The missing pieces are turning movements for the AM peak period and midday, origin-destination data, and freeway and arterial travel times.

Because traffic may vary from season to season, volume and travel time data should be collected during the same season. This will ensure that it is characteristic for at least that season. If data are gathered from different times of the year, they may not reflect conditions that prevail at any time.

Specific tasks are outlined below.

Check Previously Coded Street and Road Data for Changes

These data were coded for the CORFLO simulation undertaken by the Los Angeles Department of Transportation (LADOT). PATH has a copy of this data on disk and has the CORFLO data format so this data can be interpreted. Physical features of the network have probably changed little, if at all, since the CORFLO simulation. Therefore, the only work required is to:

- Check with the LADOT and Caltrans to see if there have been changes in freeway mainline segment length and lanes, ramp lengths and number of lanes, arterial lengths, arterial number of lanes mid-block

Estimated time required to check and modify data: 2 person-days

Check Previously Coded Operational Data and Add AM Peak and Midday Data

Operations may have changed since the previous data were coded, so operations data must be checked. Furthermore, the previous simulation dealt only with the PM peak period, so data for the AM peak and midday have not been collected or coded. The following work will be required:

- Using LADOT, Culver City, and Beverly Hills data, record parking restrictions on 100+ arterial links.
- Using LADOT diagrams of major intersections and Culver City, and Beverly Hills data, record turning restrictions and number of lanes at intersections for approximately 4 approaches to approximately 400 intersections by time of day.
- Record signal timing plans for these intersections for by time of day.
- Using Caltrans map of the Santa Monica corridor, record metering rates for 30 on-ramps
- Determine queue override logic for each on-ramp

Estimated time required to check and gather AM and midday data: 30 person-days

Obtain New Freeway Mainline and Ramp Volume Data

Volumes are believed to have changed since the last simulations new data should be collected.

- Obtain counts at 30 on-ramps and 30+ mainline freeway segments (check that loop detectors are being monitored and are accurate)
- Aggregate data into required time periods

Estimated time required to gather and aggregate data: 10 person-days

Measure Freeway Travel Times

- Using three cars equipped with tachographic instruments, measure travel times over the course of the day for three days.

- Aggregate data into required time periods.

Estimated time to gather and aggregate data: 9 person-days

Equipment required: 3 cars equipped with tachographic equipment

Gather Freeway Incident Data

- Obtain and decode computer aided dispatch (CAD) logs from the California Highway Patrol
- Record location, time, effect (number of lanes closed), and duration of incidents affecting the Santa Monica Freeway.

Estimated time required to review logs and record information: 20 person-days

Calculate Arterial Volumes

- Using loop detector data from LADOT and other cities, calculate volumes for the required time periods for each arterial section.

Estimated time required to calculate volumes: 20 person-days

Record Arterial Turning Movements

- Manually record turning movements for one day each at 110 intersections.

Estimated time required for counts: 110 person-days

Measure Arterial Travel Times

- Using one car equipped with tachographic instruments, measure travel times over the course of the day for one days on five east-west arterials and four north south arterials in the Santa Monica Corridor.
- Aggregate data into required time periods.

Estimated time to gather and aggregate data: 9 person-days

Equipment required: 3 cars equipped with tachographic equipment

Record Arterial Incident Data

- Using LADOT incident records, note location, time, effect (number of lanes closed), and duration of incidents affecting the five east-west arterials and four north south arterials in the Santa Monica Corridor.

Estimated time to record incidents: 10 person-days

Origin-Destination Data

- Using license plate survey data to identify vehicles traveling in the corridor, mail a survey to owners of these vehicles asking about trips they make in the corridor. Conduct a two-stage sample, the first stage being used to estimate the sample size needed for a valid sample.

Estimated time to design survey instrument: 5 person-days

Estimated time to process results: 60 person-days

Estimated cost for 5000 responses: \$75000

Total Resources Required for Data Collection

Estimated person-days for data collection	285	
Estimated cost of data collection @ \$15/hr with 25% benefits		\$42750
Estimated cost for conducting license plate survey		\$75000
Three cars equipped with tachographic data for 6 days		
Programming services to modify the model to include the queue override logic		

References

Bacon and May, *Analysis of Arterial Street Data from the ATSAC System*, PATH Working Paper **93-11**, August **1993**

Bacon, Windover, and May, Investigating Intelligent Transportation Systems Strategies on the Santa Monica Freeway Corridor, PATH Research Report **95-38**, November **1995**

Bloomberg and May, Freeway Detector Data Analysis for Simulation of the Santa Monica Freeway—Summary Report, PATH Working Paper **93-10**, August **1993**

Bloomberg and May, *Simulation Modeling of the Santa Monica Freeway*, PATH Working Paper **94-14**, September **1994**

JHK & Associates, Lessons Learned from the Trial of the CORFLO Model, August **1996** Kaku Associates, Smart Corridor Operations Planning element Issue Paper on Existing Traffic Conditions, Draft, March **1994**

Viggen Corporations, *Corflo Model Overview*, **1996**

People Contacted for Information

Jack Smith	Caltrans
Mohammed Kalbasi	Caltrans
Osama Assaad	Caltrans
Khaled Abasa	Caltrans
Sam Espinoza	Caltrans
Brian Gallagher	Los Angeles Department of Transportation
Sun-sun Tvedten	Los Angeles Department of Transportation
Tom Gaul	KAKU Associates
Lynn Diebold	California Highway Patrol
Sharezad Ameri	Metropolitan Transportation Authority
Hassan Ikhata	Southern California Council of Governments
Javier Minjares	Southern California Council of Governments

Appendix

Decision Analysis Regarding the Value of a Simulation Test Bed

Because the calibration and testing of the model, as well as the data collection and preparation, will be quite costly, it is wise to consider the value of such a model. The model can be useful in preventing the implementation of projects that do not have net benefits or, on the other hand, enabling implementation of worthwhile projects that would not be implemented without modeling to demonstrate their benefits. Below is a simple decision analysis that should be useful in deciding whether developing a test bed would be worthwhile.

For simplicity, assume that the Smart Corridor will implement n projects that can be simulated with the same model with the following costs:

- developing the test bed will cost D
- each simulation will cost S

Suppose each project has the following characteristics:

- the present value of the total cost of the project is C
- two outcomes, O_1 and O_2 , have benefits with net present values of $V_1 > C$ and $V_2 < C$
- the simulation will not always correctly predict the outcome—the table below shows the probabilities of correct and incorrect predictions.

Probabilities

Outcome is O_1	Outcome is O_2
P	$1-p$

Simulation shows outcome O_1	Simulation shows outcome O_2
a	$1-a$

Joint Probabilities

	Outcome is O_1	Outcome Is O_2	Outcome is O_1 or O_2
Simulation shows outcome O_1	r	$q-r$	q
Simulation shows outcome O_2	$p-r$	$1-q-p+r$	$1-q$
Simulation shows outcome O_1 or O_2	P	$1-p$	1

Conditional Probabilities

- $P\{\text{Outcome is } O_1 \text{ given simulation shows outcome } O_1\} = r/q$ true
- $P\{\text{Outcome is } O_2 \text{ given simulation shows outcome } O_1\} = (q-r)/q$ false positive
- $P\{\text{Outcome is } O_1 \text{ given simulation shows outcome } O_2\} = (p-r)/(1-q)$ false negative
- $P\{\text{Outcome is } O_2 \text{ and simulation shows outcome } O_2\} = (1-q-p+r)/(1-p) = 1 - (p-r)/(1-q)$ true

Comparison of Strategies

For each project there are three strategies:

1. Implement without simulation.
2. Simulate, and implement if simulation shows benefits greater than costs (simulation shows outcome O_1) and do not implement if simulation shows benefits less than costs (O_2).
3. Do not implement.

The expected value of each is diagramed below.

Strategy 1 – Implement without simulation

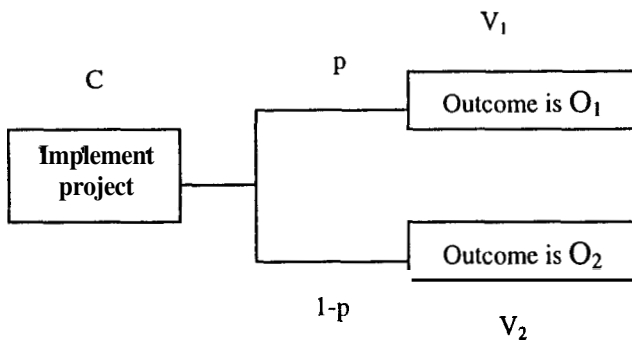

$$\text{Expected value} = pV_1 + (1-p)V_2 - C$$

Strategy 2 – Simulate and implement if simulation **shows** benefits greater than costs

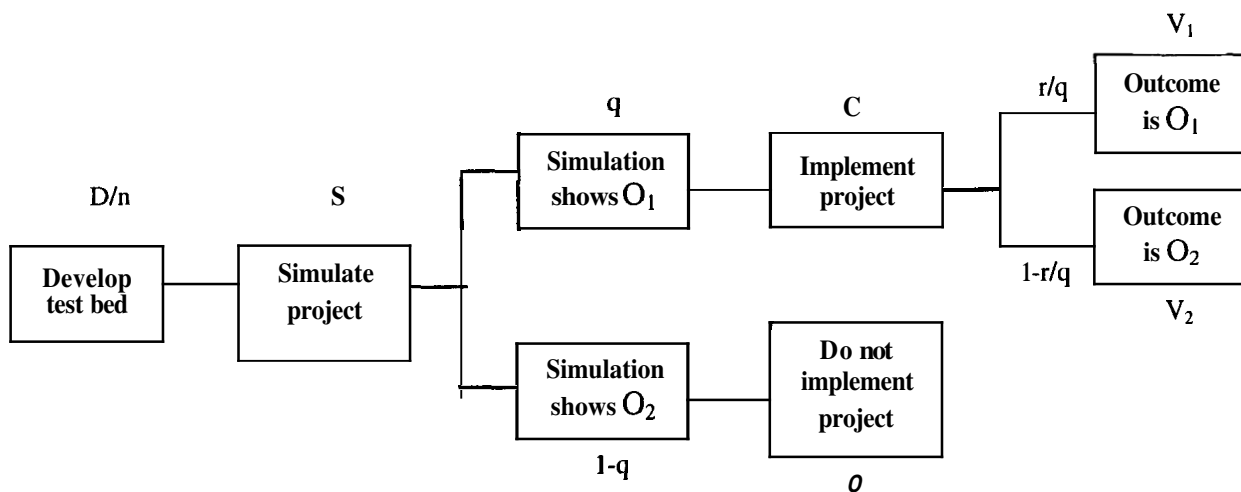

$$\text{Expected value} = [rV_1 + (q - r)V_2 - qC] - D/n - S$$

Strategy 3 – Do not implement

Expected value = 0

Simulation will be cost effective if the expected benefits of strategy 2 are greater than those of strategy 1 or strategy 3.

Comparison of Strategies 1 and 2

Given n projects, the expected benefits of strategy 2 are greater than those of strategy 1 when:

$$\sum_1^n [r_i V_{1i} + (q_i - r_i) V_{2i} - q_i C_i - D/n - S_i] > \sum_1^n [p_i V_{1i} + (1 - p_i) V_{2i} - C_i] \quad \text{or equivalently}$$

$$\sum_1^n [(1 - q_i - p_i + r_i)(C_i - V_{2i}) - (p_i - r_i)(V_{1i} - C_i)] > D + \sum_1^n S_i]$$

The first term is the probability that the outcome will be O_2 and the simulation will correctly show O_2 , and the second term is the net loss due to O_2 ; together, these terms represent the savings from identifying and not implementing a cost-ineffective project. The third term is the probability that the simulation falsely shows a negative result, and the fourth term is the net benefit due to O_1 ; together these two terms represent the loss due to not implementing a cost-effective project. The two terms on the right side of the inequality are the cost of the simulation. Strategy 2 is more cost-effective than Strategy 1 when the first and second terms are large, the third and fourth are small and the last two are small. That is, when:

- the probability is high that the outcome will not be cost-effective and that the simulation will correctly show this
- the net loss due to implementing a project that is not cost-effective is high
- the probability is low that the simulation shows a cost-effective project to not be cost-effective
- the net benefit from implementing a cost-effective project is small
- the cost of the setting up the model and running the simulations is low

Simulation is most worthwhile when many expensive and possibly ineffective projects are being considered *and* when cost-ineffective projects will not be implemented if the simulation shows them to be such.

Comparison of Strategies 2 and 3

Simulation is also cost-effective when the expected benefits of strategy 2 are greater than those of strategy 3, which occurs when:

$$\sum_1^n [r_i V_{1i} + (q_i - r_i) V_{2i} - q_i C_i - D/n - S_i] > 0 \quad \text{or equivalently}$$

$$\sum_i^n [r_i V_{1i} + (q_i - r_i) V_{2i} - q_i C_i] > D + \sum_i^n S_i$$

Here the first term represents the benefit from correctly identifying and implementing a cost-effective project. The second term represents the cost of mis-identifying and implementing a cost-ineffective project. The third term represents the cost of implementing projects. In this case simulation is worthwhile when:

- the probability is high that the outcome will be cost-effective and that the simulation will correctly show this
- the net gain due to implementing a cost-effective project is high
- the probability is low that the simulation shows a cost-ineffective project to be cost-effective
- the net cost from implementing a cost-ineffective project is small
- **the** cost of the setting up the model and running the simulations is low

Summary

A simulation is valuable if it results in implementation of worthwhile projects that would not be implemented without the simulation or if it prevents implementation of poor projects that would be implemented without the simulation. In either case, model accuracy **is** critically important. But, of course, the more accurate the simulation, the greater its cost. If the primary concern **is** that worthwhile projects are not being implemented, then simulation will be helpful to the extent that it correctly identifies these projects at a reasonable cost.