Modelling and simulation of a 1.6 Tb/s optical system based on multi-diagonal code and optical code-division multiple-access

¹Thanaa Hussein Abd, ¹S. A. Aljunid, ¹Hilal Adnan Fadhil, ¹M. N. Junita and ²N. M. Saad

¹School of Computer and Communication Engineering, University Malaysia Perlis, Malaysia, eng_thanaa@yahoo.com, syedalwee@unimap.edu.my

²Electrical and Electronic Engineering Department, University Technology Petronas, Malaysia

Received: 19.12.2011

Abstract. In this paper we have modelled and simulated a 1.6 Tb/s (100×16 Gb/s) optical system based on spectral amplitude coding for the optical code-division multiple-access (SAC-OCDMA) scheme. In order to reduce the effect of multiple-access interference, we have employed a new family of SAC-OCDMA codes called as a multi-diagonal (MD) code. The new code family based on the MD code reveals properties of zero cross-correlation code, flexibility in selecting the code parameters and support of a large number of users, combined with high data rate. Both the numerical and simulation results have demonstrated that our optical system based on the MD code can accommodate maximum numbers of simultaneous users with higher data rate transmission and lower bit error rates, when compared to the former SAC-OCDMA codes.

Keywords: spectral amplitude coding for the optical code-division multiple-access (SAC-OCDMA), multi-diagonal (MD) code, high data rate optical systems, random diagonal (RD) code, modified quadratic congruence (MQC) code.

PACS: 42.81.Uv, 42.79.Sz

UDC: 681.7.068; 512.624.95

1. Introduction

Optical code-division multiple-access (OCDMA) schemes have always been of importance because of their inherent capability of supporting asynchronous access networks, dynamic bandwidth assignment, and multimedia services [1, 2]. Furthermore, OCDMA systems have been employed for local area networks and, later on, for access network applications [3–6]. The performance of the OCDMA systems is governed by numerous quantitative parameters such as the data rate, simultaneous number of users, the powers of transmitter and receiver, and the type of codes. Among these, the types of codes and the transmitted data rate represent the most important parameters since they decide directly numbers of users that can access a network [7].

It is known that the OCDMA systems suffer from different noises such as a shot noise, thermal noise, a dark current, and a multiple-access interference (MAI) arising from other users. Of these noises, the MAI is generally considered as a dominating source. Reasonable designs of the code sequence are therefore important in order to reduce contribution of the MAI to the total power received [8]. Spectral amplitude coding for the optical code-division multiple-access (SAC-OCDMA) system offers a good solution that reduces the MAI effect by utilising codes with a fixed in-phase cross-correlation [9]. A lot of codes have been suggested for the SAC-OCDMA networks (an optical orthogonal (OOC) code [10], a prime code [11], a Khazani–Syed (KS) code [12], an

enhanced double weight (EDW) code [13], a modified frequency-hopping (MFH) code [14], a modified quadratic congruence (MQC) code [15], a random diagonal (RD) code [16], a modified double weight (MDW) code [17], etc.). These codes suffer from several limitations: the code length is often too long (e.g., for the OOC, KS and the EDW codes), the code construction is limited by the code parameter (e.g., for the MQC and MFH codes), whereas the cross-correlation usually increases with increasing weight number (e.g., for the prime code and the RD code). In addition, the codes suggested in the works [10–17] cannot support large enough numbers of simultaneous users or high data rates. To overcome these problems, we have suggested a so-called multi-diagonal (MD) code. The MD code is designed basing on combination of diagonal matrixes. This new code has several advantages, including (1) zero cross-correlation that cancels the MAI, (2) flexibility in choosing the parameters W and K (see below), if compared with the other codes like the MQC one, (3) a simple design, (4) support of a larger number of users with higher data rates, and (5) no overlapping occurred for the spectra characteristic for different users.

The present paper is organised as follows. We describe construction of the MD code in section 2 and analyse performance of our system in section 3. Section 4 is devoted to mathematical and simulation analyses and, finally, conclusions are drawn in section 5.

2. Design of the MD code

The MD code is characterised by the parameters N , W and λ_c , where N is the code length (i.e., the number of total chips), W the code weight (the number of chips having the unit value), and λ_c the in-phase cross-correlation.

Now let us formulate the cross-correlation theorem. First let us introduce, as usual in the linear algebra, the identity (or unit) matrix of size N as an N -by- N square matrix with unit components on its main diagonal and zero components elsewhere. It is denoted as I_N , or simply I , if the size is immaterial. Eventually, it can be defined as follows:

$$I_1 = [1], I_2 = \begin{bmatrix} 1 & 0 \\ 0 & 1 \end{bmatrix}, I_3 = \begin{bmatrix} 1 & 0 & 0 \\ 0 & 1 & 0 \\ 0 & 0 & 1 \end{bmatrix}, \dots, I_N = \begin{bmatrix} 1 & 0 & 0 & 0 \\ 0 & 1 & 0 & 0 \\ 0 & 0 & \ddots & 0 \\ 0 & 0 & \dots & 1 \end{bmatrix}. \quad (1)$$

Using a notation used sometimes to concisely describe diagonal matrices, we can write $I_N = \text{diag}(1, 1, \dots, 1)$. The orthogonal matrix represents a square matrix with real entries whose columns and rows are orthogonal unit vectors. In other words, a matrix A is orthogonal if its transpose is equal to its inverse: $A^T A = A A^T = I$.

Now, the cross-correlation theorem states that certain sets of complementary sequences have cross-correlation functions that sum to zero by using all pairwise permutations. Here, all cross-correlation function permutations are required in order that their sum be identically equal to zero. For example, if the rows and columns of a $(K \times N)$ matrix are orthogonal and all the columns except one sum to zero, then the sum of all cross-correlations among non-identical codewords is zero.

So if x_{ij} is an entry from X and y_{ij} is an entry from Y , then an entry from the product $C = XY$ is given by $C_{ij} = \sum_{k=1}^N x_{ik} y_{kj}$. For the code sequences $X = (x_1, x_2, x_3, \dots, x_N)$ and $Y = (y_1, y_2, y_3, \dots, y_N)$, the cross-correlation function may be represented by $\lambda_c = \sum_{i=1}^N x_i y_i$. When

$\lambda_c = 0$, it is considered that the code possesses zero cross-correlation properties. The matrix of the MD code represents a $K \times N$ matrix depending functionally on the number of users K , and the code weight W . For the MD code, the choice of the weight value is free, though it should be larger than unity ($W > 1$). The following steps explain how the MD code is constructed.

Step 1

First, let us construct a sequence of diagonal matrices using specific values of the weight W and the number of subscribers K . According to these values, we have the set i, j_W . Here K and W are positive integer numbers, so that $(i = 1, 2, 3, 4, \dots, i_n = K)$ are defined by the number of rows in each matrix, and $(j_W = 1, 2, 3, 4, \dots, W)$ represent the number of diagonal matrices.

Step 2

The MD sequences are computed for each diagonal matrix basing on the relations

$$S_{i,j_W} = \begin{cases} (i_n + 1 - i), & \text{For } j_W = \text{even number} \\ i, & \text{For } j_W = \text{odd number} \end{cases}, \quad (2)$$

$$S_{i,1} = \begin{bmatrix} 1 \\ 2 \\ 3 \\ \vdots \\ K \end{bmatrix}, S_{i,2} = \begin{bmatrix} K \\ \vdots \\ 2 \\ 1 \end{bmatrix}, S_{i,3} = \begin{bmatrix} 1 \\ 2 \\ \vdots \\ K \end{bmatrix}, \dots, S_{i,W} = \begin{bmatrix} 1 \\ 2 \\ \vdots \\ K \end{bmatrix}. \quad (3)$$

It is evident that $T_{i,1} = [S_{i,1}]_{K \times K}$, $T_{i,2} = [S_{i,2}]_{K \times K}$ and $T_{i,W} = [S_{i,W}]_{K \times K}$. Therefore we get

$$T_{i,1} = \begin{bmatrix} 1 & 0 & \dots & 0 \\ 0 & 1 & \dots & 0 \\ \vdots & \vdots & \ddots & \vdots \\ 0 & 0 & \dots & 1 \end{bmatrix}_{K \times K}, T_{i,2} = \begin{bmatrix} 0 & \dots & 0 & 1 \\ 0 & \dots & 1 & 0 \\ \vdots & \ddots & \vdots & \vdots \\ 1 & \dots & 0 & 0 \end{bmatrix}_{K \times K}, \dots, T_{i,W} = \begin{bmatrix} 1 & 0 & \dots & 0 \\ 0 & 1 & \dots & 0 \\ \vdots & \vdots & \ddots & \vdots \\ 0 & 0 & \dots & 1 \end{bmatrix}_{K \times K} \quad (4)$$

Step 3

The total combination of diagonal matrices given by Eq. (3) represents the MD code as a $K \times N$ matrix:

$$MD = [T_{i,1} : T_{i,2} : \dots : T_{i,W}]_{K \times N}, \quad (5)$$

$$MD = \begin{bmatrix} a_{1,1} & a_{1,2} & \dots & a_{1,N} \\ a_{2,1} & a_{2,2} & \dots & a_{2,N} \\ a_{3,1} & a_{3,2} & \dots & a_{3,N} \\ \vdots & \vdots & \dots & \vdots \\ a_{i_n,1} & a_{i_n,2} & \dots & a_{i_n,N} \end{bmatrix}. \quad (6)$$

In the basic matrix given by Eq. (5), the rows determine the number of users. Notice that the association between the code weight, the code length and the number of subscribers may be expressed as

$$N = K \times W. \quad (7)$$

In order to generate the MD code family according to the previous steps, let us put, as an example, $K = 4$ and $W = 3$. Then $i = 1, 2, 3, 4$, $i_n + 1 = 5$, and $j_W = 1, 2, 3$.

The diagonal matrices can be expressed as

$$S_{i,1} = \begin{bmatrix} 1 \\ 2 \\ 3 \\ 4 \end{bmatrix}, S_{i,2} = \begin{bmatrix} 4 \\ 3 \\ 2 \\ 1 \end{bmatrix}, S_{i,3} = \begin{bmatrix} 1 \\ 2 \\ 3 \\ 4 \end{bmatrix} \quad (8)$$

The MD code sequence for each of the diagonal matrices is defined by

$$T_{i,1} = \begin{bmatrix} 1 & 0 & 0 & 0 \\ 0 & 1 & 0 & 0 \\ 0 & 0 & 1 & 0 \\ 0 & 0 & 0 & 1 \end{bmatrix}_{4 \times 4}, T_{i,2} = \begin{bmatrix} 0 & 0 & 0 & 1 \\ 0 & 0 & 1 & 0 \\ 0 & 1 & 0 & 0 \\ 1 & 0 & 0 & 0 \end{bmatrix}_{4 \times 4}, T_{i,3} = \begin{bmatrix} 1 & 0 & 0 & 0 \\ 0 & 1 & 0 & 0 \\ 0 & 0 & 1 & 0 \\ 0 & 0 & 0 & 1 \end{bmatrix}_{4 \times 4}, \quad (9)$$

and the total MD code sequence would be

$$MD = \begin{bmatrix} 1 & 0 & 0 & 0 & 0 & 0 & 0 & 1 & 1 & 0 & 0 & 0 \\ 0 & 1 & 0 & 0 & 0 & 0 & 1 & 0 & 0 & 1 & 0 & 0 \\ 0 & 0 & 1 & 0 & 0 & 1 & 0 & 0 & 0 & 0 & 1 & 0 \\ 0 & 0 & 0 & 1 & 1 & 0 & 0 & 0 & 0 & 0 & 0 & 1 \end{bmatrix}_{4 \times 12}, \quad (10)$$

where $K = 4$ and $N = 12$.

So, the codeword for each user according to the example cited above would be as follows:

$$\text{codeword} = \begin{cases} \text{user 1} \Rightarrow \lambda_1, \lambda_8, \lambda_9 \\ \text{user 2} \Rightarrow \lambda_2, \lambda_7, \lambda_{10} \\ \text{user 3} \Rightarrow \lambda_3, \lambda_6, \lambda_{11} \\ \text{user 4} \Rightarrow \lambda_4, \lambda_5, \lambda_{12} \end{cases}.$$

The design of the MD code depicts the fact that changing matrix components in the same diagonal part would result in invariable zero cross-correlation. That is why it is constructed with zero cross-correlation properties, which cancel the MAI. The MD code offers more flexibility in choosing the W and K parameters and, together with simple design, this can yield in larger numbers of users, if compared with the other codes like the MQC and RD ones. Furthermore, there are no overlapping chips for different users.

Table 1. Comparison of different properties of the MD code and the other codes used for the SAC-OCDMA systems.

No	Codes	Number of users K	Weight W	Code length N	Cross-correlation λ_c
1	OOC	30	4	364	1
2	Prime code	30	31	961	2
3	RD	30	4	35	Variable λ_c in the code segment
4	MQC	30	8	56	1
5	MDW	30	4	90	1
6	EDW	30	3	60	1
7	KS	30	4	144	1
8	MD	30	2	60	0

Table 1 shows the code length N , the weight W and the cross-correlation value λ_c required for each code type to support only 30 users. Notice that the MQC and RD codes show shorter code lengths than that of the MD one, the point that will be discussed in detail further on. It will be

shown that the transmission performance of the MD code is significantly better than that of the MQC and RD codes, as testified by both numerical and simulation analyses. Furthermore, only the MD code can support 30 users with the weight $W = 2$ and a zero cross-correlation ($\lambda_c = 0$).

3. System performance analysis

3.1 Gaussian approximation

In order to analyse our system, we use the Gaussian approximation for calculating the bit error rate (BER) parameter [14]. In particular, we have considered the effect of thermal noise (σ_{th}) and shot noise (σ_{sh}) in a photodetector. The signal-to-noise ratio (SNR) for the electrical signal is defined as a ration of the average signal power (I^2) to the noise power $SNR = [I^2 / \sigma^2]$. Due to the zero cross-correlation property of the MD code, there is no overlapping in the spectra associated with different users. For this reason the effect of incoherent intensity noise has been ignored.

Any variation of the photodetector signal is a result of detection of an ideally nonpolarised thermal light, which is generated due to spontaneous emission. This variation may be expressed via the relation

$$\begin{aligned}\sigma^2 &= \sigma_{sh} + \sigma_{th}, \\ \sigma^2 &= 2eBI + \frac{4K_b T_n B}{R_L},\end{aligned}\quad (11)$$

where e denotes the electron charge, I the average photocurrent, B the electrical bandwidth, K_b the Boltzmann constant, T_n the receiver noise temperature, and R_L the receiver load resistor.

Let $C_K(i)$ denote the i th element of the K th MD code sequence. According to the properties of the MD code, the direct detection technique would result in

$$\sum_{i=1}^N C_K(i)C_l(i) = \begin{cases} W, & \text{for } K = l \\ 0, & \text{else} \end{cases} . \quad (12)$$

Here the following assumptions can be made [14, 16]:

- each light source is ideally nonpolarised and its spectrum is flat over its entire bandwidth $[v_0 - \Delta\nu/2; v_0 + \Delta\nu/2]$, where v_0 is the central optical frequency and $\Delta\nu$ the optical source bandwidth expressed in Hertz;
- each power spectral component has an identical spectral width;
- each user has an equal power at the transmitter;
- each bit stream from each user is synchronised.

The above assumptions are important for mathematical straightforwardness. Devoid of these assumptions (e.g., if the power of each spectral component were not identical and each user had a different power at the receiver), it would be difficult to analyse our system.

The power spectral density of the optical signals received may be written as [18]

$$r(\nu) = \frac{P_{sr}}{\Delta\nu} \sum_{K=1}^K d_K \sum_{i=1}^N c_K(i) \text{rect}(i), \quad (13)$$

where P_{sr} means the effective power of the broadband source at the receiver, K the number of active users, N the MD-code length, and d_K the data bit of the K th user, which is either '1' or '0'.

The function $\text{rect}(i)$ in Eq. (13) is given by

$$\text{rect}(i) = u\left[v - v_0 - \frac{\Delta v}{2N}(-N + 2i - 2)\right] - u\left[v - v_0 - \frac{\Delta v}{2N}(-N + 2i)\right] = u\frac{\Delta v}{2N}, \quad (14)$$

where $u(v)$ is the unit step function,

$$u(v) = \begin{cases} 1, & v \geq 0 \\ 0, & v < 0 \end{cases}. \quad (15)$$

Basing on Eq. (13), we write the integral for the power spectral density at the photodetector of the l th receiver over one period:

$$\int_0^{\infty} G(v)dv = \int_0^{\infty} \left[\frac{P_{sr}}{\Delta v} \sum_{K=1}^K d_K \sum_{i=1}^N C_K(i)C_l(i) \text{rect}(i) \right] dv. \quad (16)$$

As a result, we get

$$\int_0^{\infty} G(v)dv = \frac{P_{sr}W}{N} \quad (17)$$

Then the photocurrent I may be found as

$$I = \Re \int_0^{\infty} G(v)dv, \quad (18)$$

where \Re is the responsivity of the photodetector given by $\Re = \eta e/hv_c$ [12]. Here η is the quantum efficiency, h the Planck constant, and v_c the central frequency of the original broad-band optical pulse.

Then Eq. (18) may be written as

$$I = \Re \int_0^{\infty} G(v)dv = \frac{\Re P_{sr}W}{N}. \quad (19)$$

Substituting Eq. (19) into Eq. (11), we obtain

$$\sigma^2 = \frac{2eB\Re P_{sr}W}{N} + \frac{4K_b T_n B}{R_L}. \quad (20)$$

Since the probability of sending a bit '1' to each user is $1/2$ at any time, Eq. (20) becomes

$$\sigma^2 = \frac{eB\Re P_{sr}W}{N} + \frac{4K_b T_n B}{R_L}. \quad (21)$$

From Eqs. (19) and (21) we can finally calculate the average SNR:

$$SNR = \left[\frac{\left(\frac{\Re P_{sr}W}{N} \right)^2}{\frac{eB\Re P_{sr}W}{N} + \frac{4K_b T_n B}{R_L}} \right]. \quad (22)$$

Using the Gaussian approximation, we may express the BER parameter as (see [16])

$$BER = P_e = \frac{1}{2} \text{erfc} \left(\sqrt{\frac{SNR}{8}} \right). \quad (23)$$

3.2. SAC-OCDMA transceiver system based on direct detection technique

The receiver in the MD-code system employs direct detection technique for two different users, which is illustrated in Fig. 1. Only single pair of decoder and detector is then required, in contrast

to the other techniques requiring two branches of inputs to the receiver, like those used in complementary subtraction techniques. There is also no subtraction process involved. This is achievable for a simple reason: the information is assumed to be adequately recoverable from any of the chips that do not overlap with any other chips from the other code sequences, since the MD code is designed with no overlapping chips. Thus, the detector will only need filtering through the clean chips (no overlapping chips) and direct detecting with the photodiode of a normal intensity modulation, using a direct detection scheme. The MAI effect has been suppressed completely because only the signal spectra required in the optical domain will be filtered.

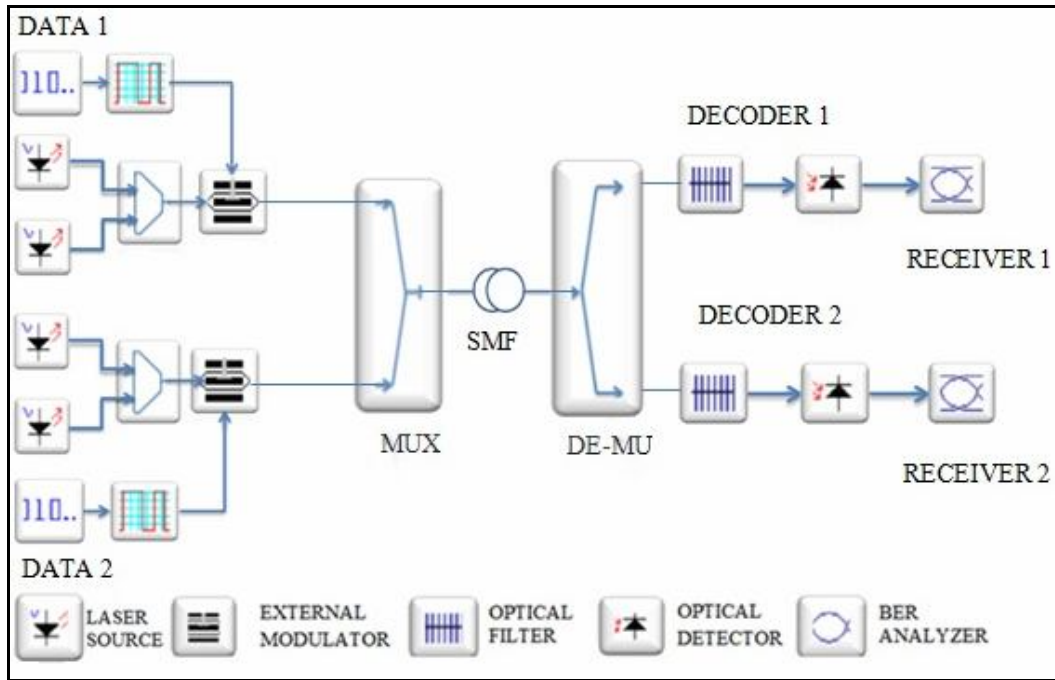

Fig. 1. Illustration of block diagram of the MD-code system that uses a direct detection technique.

4. Numerical and simulation analyses

4.1 Numerical analysis

This section presents numerical analysis of the performance of the MD code, using standard MATLAB software. The performance of the system is characterised by referring to the *BER*. Eq. (23) has been employed to calculate the *BER* for the MD code. To ensure fair performance comparison for the MD-code system, the present study uses the same parameters as adopted in the earlier works [10–17]. Table 2 lists the parameters chosen in the calculations for the MD and the other SAC-OCDMA codes.

Fig. 2 shows how the *BER* value varies depending on the number of active users for different codes employed by the SAC-OCDMA technique. Here the data rate is 622 Mb/s for each user and the effective broadband power amounts to -10 dBm. It is seen that the performance of the MD code is better when compared to the others, even though the weights of the other codes are larger than the MD code weight. The maximum acceptable *BER* of 10^{-9} is achieved for the MD code with 92 active users (to be compared with 43 active users for the MQC, 59 for the RD, and 27 for the MFH code). This is very good, considering a small weight value used. This result is evident to

be due to the fact that the MD code has zero cross-correlation properties, with a diagonal matrix design, while the other codes have the cross-correlations varying between zero and unity, and also very long code lengths. Several code-specific parameters have been chosen basing on the results published for these practical codes [14–16]. We have calculated the *BERs* putting $W = 4, 5, 12$ and 14 for the MD, RD, MFH and MQC codes, respectively.

Table 2. Typical parameters used in our numerical analysis.

Symbol	Parameter	Value
η	Photodetector quantum efficiency	0.6
P_{sr}	Broadband effective power	-10 dBm
B	Electrical bandwidth	311 MHz
λ_0	Operating wavelength	1550 nm
R_b	Data bit rate	622 Mb/s
T_n	Receiver noise temperature	300 K
R_L	Receiver load resistor	1030 Ohm

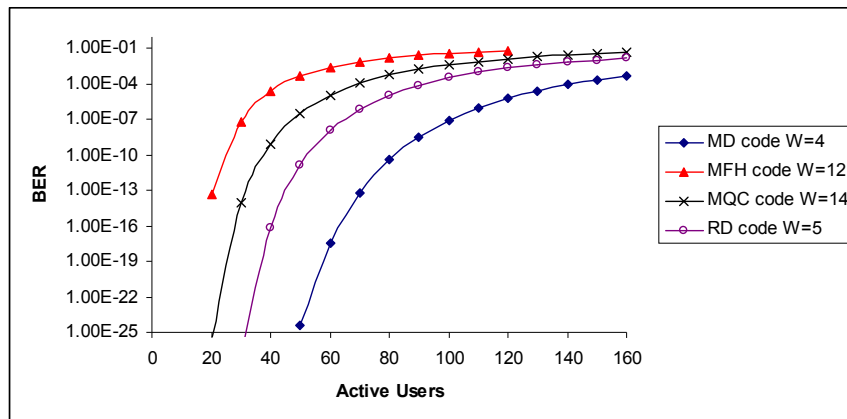

Fig. 2. Dependences of *BER* on the number of active users for different codes employed by the SAC-OCMA technique ($P_{sr} = -10$ dBm).

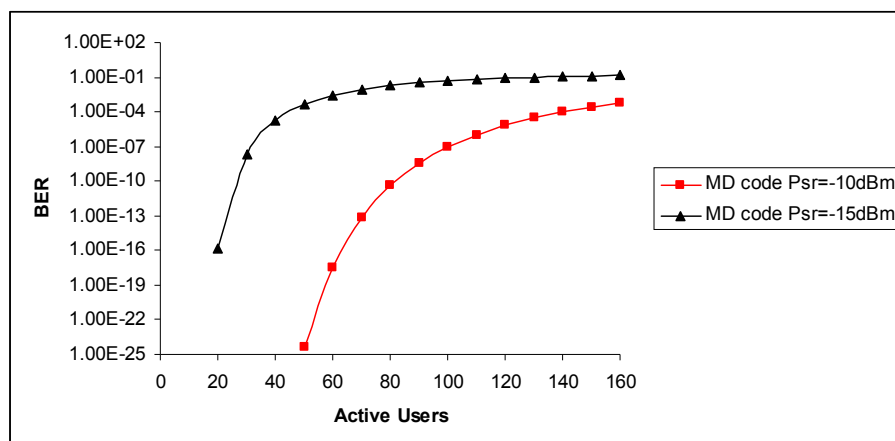

Fig. 3. Dependences of *BER* on the number of active users plotted for different P_{sr} values.

Fig. 3 shows dependences of the *BER* upon the number of simultaneous users for different effective light powers, which take into account the effects of both thermal and shot noises. It is clearly recognised from Fig. 3 that the *BER* of the system increases with increasing number of simultaneous users and decreasing effective light power. Here the MD-code system (with $W = 4$, $P_{sr} = -10$ dBm, and $R_b = 622$ Mb/s) can operate with 90 simultaneous users.

4.2 Simulation analysis

The performance for the MD code has also been simulated using the software Optisystem (Version 9.0). A simple circuit design includes three users, as illustrated in Fig. 4 with the aid of the simulation software.

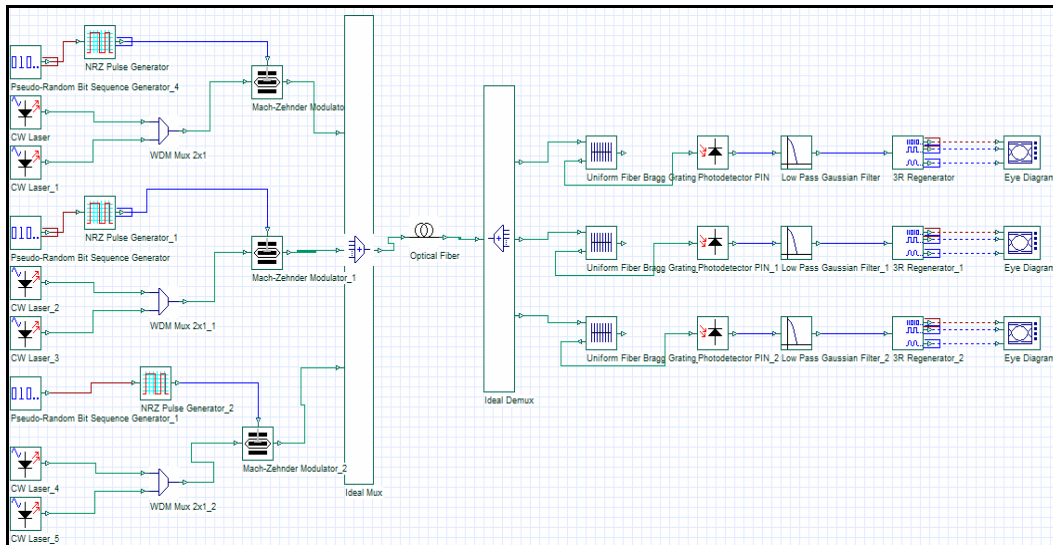

Fig. 4. Schematic block diagram of the MD code for the case of three users.

The tests have been carried out for the rate 16 Gb/s and a 20 km long standard single-mode optical fibre ITU-T G.652. The power of the light source has been fixed at -5 dBm, with the spectral width 0.4 nm for each chip. All of the significant effects have been activated (i.e., the attenuation (0.25 dB/km), the dispersion (18 ps/(nm × km)), and the nonlinear effects). The corresponding parameters have been specified according to their typical industrial values, in order to simulate the environment as close as possible. The performance of the system has been characterised by referring to the *BER* and the eye patterns (see [19]). Furthermore, a fibre Bragg grating and an avalanche photodetector have been employed to decode optical signals. The noise generated at the receivers has been set to be random and totally uncorrelated. The dark current and the thermal noise coefficient have been taken to be respectively 5 nA and 1.8×10^{-23} W/Hz for each of the photodetectors.

As seen from Fig. 5a and Fig. 5b, the eye patterns clearly reveal that the MD-code system (1.6 Tb/s or 16 Gb/s × 100 users) achieves its maximum *BER* value (2.1×10^{-12}) with using no amplifier or a side pump. Here Fig. 5a and Fig. 5b represent the eye diagrams respectively for the first and 100th channels, when the fibre length is fixed at 20 km and the data rate is equal to 16 Gb/s. The height of the eye opening at the specified sampling time shows the noise margin, or the immunity to that noise.

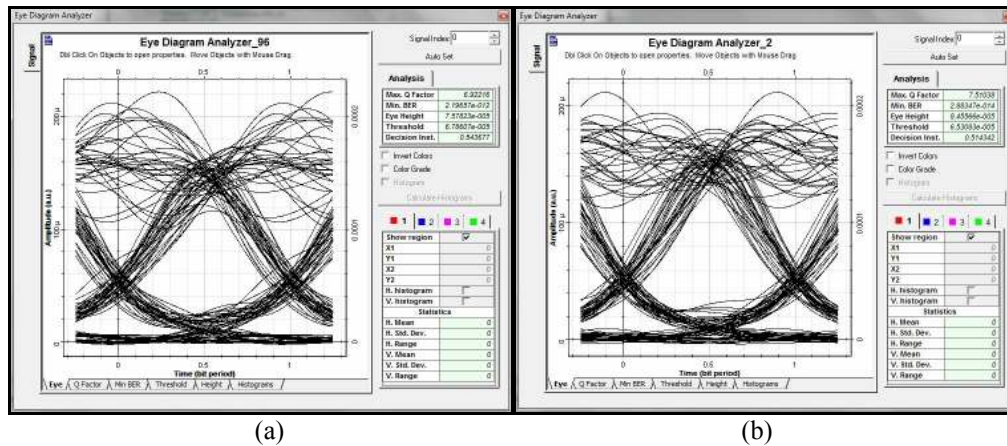

Fig. 5. Eye diagrams for the first (a) and 100th (b) channels of the MD-code system (100 channels at 16 Gb/s, 20 km, and 0 dBm).

The MD-code system has been compared with the SAC-OCDMA systems employing the other codes such as the RD, the EDW, the MQC and the MFH ones. The eye pattern diagrams for some of them are shown in Fig. 6 to 8. The RD, MQC and MD codes have been tested for the laser

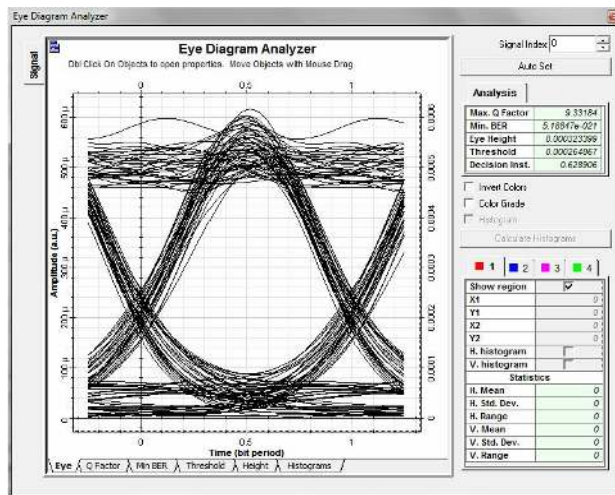

Fig. 6. Eye diagram for the MD-code system (the case of five users, $W = 2$, 10 Gb/s, and 20 km).

Here the vertical distance between the top of the eye opening and the maximum signal level gives a degree of distortion.

Finally, Fig. 9 shows variations of the BER as a function of data rate for the case of five optical channels and different input powers. One can see that the input power of the light source has a significant impact on the system performance, especially when the data rate increases. Fig. 9 indicates that, for a fibre length fixed at 20 km, the system performance deteriorates with decreasing input light source power and increasing data rate. The system achieves low BER values when the light source power decreases from 0 dBm to -10 dBm. At the same time, the system is characterised by the parameter $BER = 9.15 \times 10^{-16}$ at 10 Gb/s, for low input power (-10 dBm). As a consequence, in order to optimise the system and provide the parameters preferred by a designer, the maximum fibre length should be made as short as possible. The latter would ensure high data rates and a desired system performance with resorting to no dispersion-compensating devices.

source power of 0 dBm (the fibre lengths of 20 km and 10 km have been chosen for the MD and RD codes and the MQC code, respectively). The eye diagrams clearly testify that the MD-code system that uses direct detection provides better performance (the corresponding eye diagram is associated with larger eye opening). The simulated BER values are $BER = 5.1 \times 10^{-21}$, 2.4×10^{-12} and 4.1×10^{-9} for the MD-, RD- and MQC-code systems, respectively.

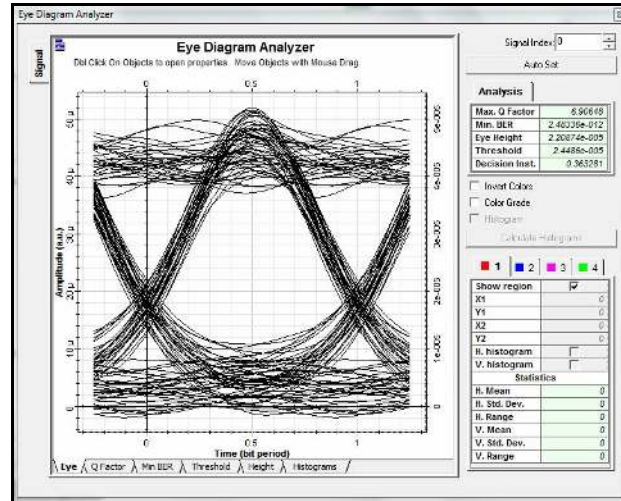

Fig. 7. Eye diagram for the RD-code system (the case of four users, $W = 3$, 10 Gb/s, and 20 km).

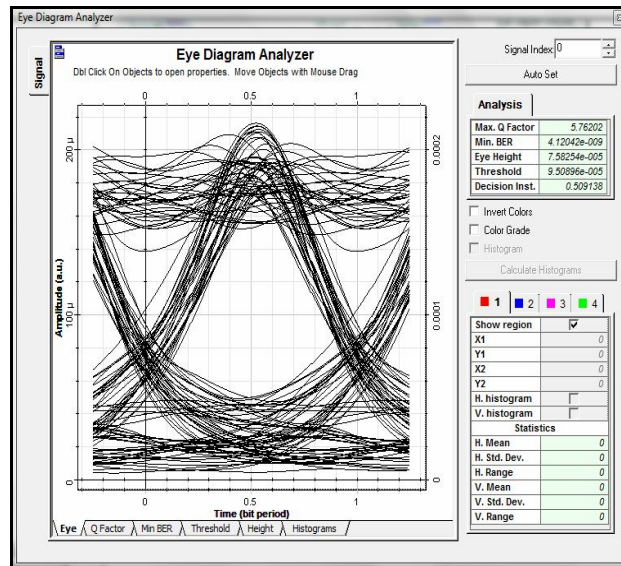

Fig. 8. Eye diagram for the MQC-code system (the case of four users, $W = 3$, 10 Gb/s, and 10 km).

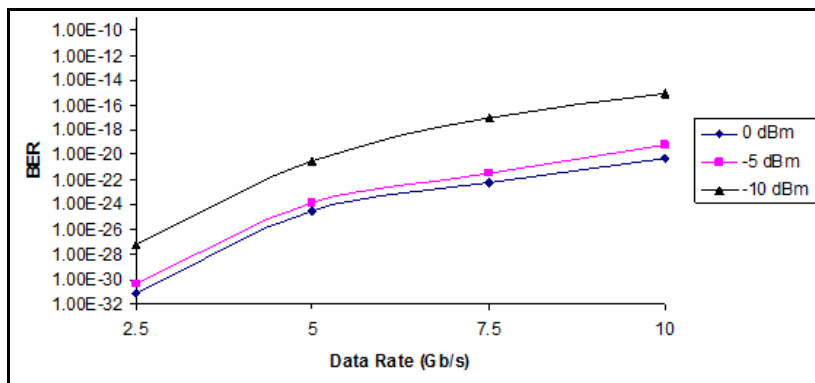

Fig. 9. Dependences of BER on the data rate for different input powers and a 20 km distance.

5. Conclusions

We have been successful in modelling and simulating of a SAC-OCDMA system basing upon the MD code and operating at 1.6 Tb/s (16Gb/s×100 users). Because of zero cross-correlation property peculiar of the MD code, the design of the encoder/decoder is simple, thus reducing complexity of the system. The appropriate decoder is designed basing on a direct detection technique, owing to the fact that the code ensures no overlapping occurring for the spectra linked to different users. Therefore, the MD-code system achieves the lowest *BER* (5.1×10^{-21}), when compared to the other SAC-OCDMA codes used formerly (e.g., the MQC and RD codes). On the other hand, optimising some parameters of the system, obtaining higher data rates and better system performance with a maximum number of simultaneous users, as well as relying on no dispersion compensation devices, demand that the maximum fibre lengths should be relatively short.

References

1. Hongxi Yin, Wei Liang, Le Ma and Liqiao Qin, 2009. A new family of two-dimensional triple-codeweight asymmetric optical orthogonal code for OCDMA networks. *Chin. Opt. Lett.* **7**: 102–105.
2. Chen Biao, Wang Fu-chang, Hu Jian-dong and He Sai-ling, 2005. A novel OCDMA drop unit based on fiber gratings and 2D wavelength-time codes. *Optoelect. Lett.* **1**: 53–56.
3. Prucnal P R, Santoro M A and Fan T R, 1986. Spread spectrum fiber-optic local area network using optical processing. *J. Lightwave Technol.* **LT-4**: 547–554.
4. Pfeiffer T, Deppisch B, Witte M and Heidemann R, 1999. Operational stability of a spectrally encoded optical CDMA system using inexpensive transmitters without spectral control. *IEEE Photon. Technol. Lett.* **11**: 916–918.
5. Pfeiffer T, Schmuck H, Deppisch B, Witte M and Kissing J, 2000. TDM/CDM/WDM approach for metro networks with 200 optical channels. *Proc. 26th ECOC (Munich, Germany)*. **3**: 77–78.
6. Zouine Y, Dayoub I, Haxha S and Rouvaen J M, 2008. Analyses of constraints on high speed optical code division multiplexing access (OCDMA) link parameters due to fiber optic chromatic dispersion. *Opt. Commun.* **281**: 1030–1036.
7. Hernandez V J, Mandez A J, Bennett C V, Gagliardi R M and Lennon W J, 2005. Bit error rate analysis of a sixteen-user gigabit Ethernet optical-CDMA (O-CDMA) technology demonstrator using wavelength/time codes. *IEEE Photon. Technol. Lett.* **17**: 2784–2786.
8. Stok A and Sargent E H, 2000. Lighting the local network: Optical code division multiple access and quality of service provisioning. *IEEE Network.* **14**: 42–46.
9. Mohammed Noshad and Kambiz Jamshidi, 2010. Code family for modified spectral-amplitude-coding OCDMA system and performance analysis. *J. Opt. Commun. Netw.* **2**: 344–354.
10. Salehi J A, 1989. Code division multiple access technique in optical fiber networks. Part II: System performance analysis. *IEEE Trans. Commun.* **37**: 834–842.
11. Yang G–C and Kwong W C. Prime code with applications to CDMA optical and wireless networks. Boston: Artech House (2002).
12. Ahmad Anas S B, Abdullah M K, Mokhtar M, Aljunid S A and Walker S D, 2009. Optical domain service differentiation using spectral-amplitude-coding. *J. Opt. Fib. Technol.* **15**: 26–32.
13. Hasson F N, Aljunid S A, Samad M D A and Abdullah M K, 2008. Spectral amplitude coding

- OCDMA using AND subtraction technique. Appl. Opt. **47**: 1263–1268.
14. Wei Z H, Shalaby M and Shiraz H G, 2001. New code families for fiber-Bragg-grating-based spectral-amplitude-coding optical CDMA systems. IEEE Photon. Technol. Lett. **13**: 890–892.
 15. Wei Z, Shalaby H M H and Ghafouri-Shiraz H, 2001. Modified quadratic congruence codes for fiber Bragg-grating based spectral-amplitude coding optical CDMA system. J. Lightwave Technol. **19**: 1274–1281.
 16. Hillal Adnan Fadhil, Aljunid S A and Ahmed R B, 2009. Effect of random diagonal code link of an OCDMA scheme for high-speed access networks. J. Opt. Fib. Technol. **15**: 237–241.
 17. Aljunid S A, Ismail M and Ramil A R, 2004. A new family of optical code sequence for spectral-amplitude-coding optical CDMA systems. IEEE Photon. Technol. Lett. **16**: 2383–2385.
 18. Yang C–C, Huang J–F and Tseng S–P, 2004. Optical CDMA network codes structured with M-sequence codes over waveguide-grating routers. IEEE Photon. Technol. Lett. **16**: 641–643.
 19. Gerd Keiser. Optical fiber communications (3rd edition), New York: Mc Graw-Hill (1986).

Thanaa Hussein Abd, S. A. Aljunid, Hilal Adnan Fadhil, M. N. Junita and N. M. Saad, 2012. Modelling and simulation of a 1.6 Tb/s optical system based on multi-diagonal code and optical code-division multiple-access. Ukr.J.Phys.Opt. **13**: 54 – 66.

***Анотація.** У цій роботі змодельовано конструкцію оптичної системи зі швидкістю 1,6 Тбіт/с (100×16 Гбіт/с) на основі спектрального кодування амплітуди і оптичного множинного доступу з кодовим розподілом каналів. Для зменшення впливу завад множинного доступу використано нову родину кодів, а саме мультидіагональний код. Ця родина кодів володіє властивостями нульової крос-кореляції, гнучкості у виборі параметрів коду та підтримки значної кількості користувачів за високої швидкості передачі даних. Результати моделювання та розрахунків засвідчують, що, порівняно з колишніми системами кодів, оптична система, заснована на мультидіагональному коді, здатна забезпечити вищу швидкість передачі даних до максимальної кількості одночасних користувачів за умови нижчої вірогідності помилок.*