

Modelling of the Computer Classroom Electromagnetic Field

P. Baltrenas, R. Buckus, S. Vasarevicius

*Department of Environment Protection, Vilnius Gediminas Technical University,
Saulėtekio al. 11, LT-10223 Vilnius, Lithuania, phone: +37067812037, e-mail: raimisbc@gmail.com*

Introduction

A modern computer represents a sophisticated system composed of several electric and radio electronic devices with different physical operation principles [1–9]. All equipment is arranged compactly in the power plants [1]. Simple electric devices use voltage they receive from an electricity network. Meanwhile more advanced equipment, such as displays, change the frequency, level and form of supply voltage depending on their functions [7]. For a display to function various frequencies and an electric current of different forms (sine, saw-toothed or rectangular impulses) are necessary and, therefore, electromagnetic fields of a wide-frequency spectrum are radiated [8]. The most obvious threat in this respect is caused by a display which, due to its complicated principle of operation, has a wide range of radiation from several hertz to a half-megahertz. In this situation the main problem lies in the fact that a display always sits in front of a user who spends the whole working day or a big part thereof in front of it [5]. The impact of electromagnetic fields on people's health remains not properly estimated. Many articles reports can be found concerning this problem. There is some computer equipment testing laboratory like at Kaunas University of Technology (KTU) for exploring of electromagnetic radiation of computer displays.

An electronic lamp used in monitors is a vacuum glass tube one end of which consists of the source of electrons and the other has a screen covered with phosphorus from inside. Use of high voltage generates an electron beam which is directed towards the screen.

An electrostatic field is generated by the electric charges of electrodes which are necessary for electrons to acquire acceleration in the electronic tube. This results in the formation of a difference in potentials between the monitor screen and the user. The electrostatic field around the user depends not only on the field created by the monitor but also on a difference in potentials between the user and things in his surroundings. The electromagnetic waves propagating through the atmosphere are attenuated by various factors also [4]. This potential difference forms at the time charge carriers settle on the person's body when

walking on carpet flooring or in case of contact among his clothes.

When electrons strike against the phosphoric layer of the screen, visible light and a small amount of UV rays are radiated. Apart from that, the interaction of electron beams and phosphorus leads to the formation of the ionising radiation of low energies. Monitor's electronic components and electric circuit which control the movement of an electron beam also create in the range of radiation radio waves.

Radiations of all kinds are emitted from the monitor in different directions. Consequently, research should involve the measurement of electromagnetic radiation spreading from the monitor in all directions [6]. The most difficult task is to evaluate electromagnetic fields propagated by several or even a dozen monitors because electromagnetic fields intertwine, thus providing additional strength to each other. The best way to evaluate situation is to model electromagnetic fields using the baseline data.

The problems of electromagnetic field investigation are formulated in the language of mathematics, and are rarely solved using analytical methods. The main method of electromagnetic field problem investigation and solving is digital methods [10]. Their application has considerably expanded the limits of knowledge and accelerated the implementation of theoretical results in practice.

Mathematical modelling of electromagnetic processes can be explained as a computer-aided analytical or digital solving of equations aimed at obtaining information about the ways of electromagnetic field propagation under certain conditions. The totality of these subjects means the modelling of electromagnetic fields. Such modelling is applied in many fields of science and engineering, but to have it applicable its results must actually represent the propagation of electromagnetic fields.

VIZIMAG represents computer codes which model the processes of electromagnetic field propagation. Such processes are occurring in many office, video and audio systems. VIZIMAG-aided modelling facilitates a forecast and understanding of electromagnetic field propagation. Modelling may involve different aspects. In the process of modelling physical laws are described by mathematical

equations. Interface, geometrical model drawing tools and efficient solver considerably shorten modelling duration. The software uses the finite integral technique (FIT) [2], which, evaluating the energy conservation law, first describes the Maxwell equations on a spatial grid and then forms specific differential equations. The method can be realised in the frequency or time domain [3]. There are limitations as regards the device's resolution grid: alongside the usual rectangular grid, non-rectangular grids are also maintained in the Cartesian coordinate system.

VIZIMAG allows resolution lines to start and end at any analysed point. Therefore, propagation of electromagnetic fields along isodynamic lines can be presented in the presence of any form of elements. This additionally increases the accuracy of analysis. Even though the user can easily change the grid in order to more accurately describe the object in critical areas of the structure under modelling, the system itself, with the help of special expert system, automatically selects the optimum grid [5].

The initial result of modelling – generalised parameters of the spread matrix for any number of modes in each entry. The calculated parameters may be presented in different forms: charts, lines of electric field strength and magnetic flux density or saved in a file.

The aim of the work is to perform modelling of the propagation of electric field strength and magnetic flux density by highlighting two frequencies – low (5 Hz - 2 kHz) and high (2 kHz - 400 kHz).

Object and methods of research

Investigations of electromagnetic fields were carried out in a computer classroom with 18 computers: nine new flat-screen LCD monitors and nine old-type tube CRT monitors.

A measuring instrument was positioned so that monitor screen's centre should match the measuring head centre and was withdrawn by a 50 cm distance from the screen surface.

The first measurement completed, the monitor was revolved around its geometric axis. The readings of the measuring instrument were recorded every 22.5° when measuring the alternating electric field and alternating magnetic field (Fig. 2.).

16 measurements for each computer's monitor were taken at a low frequency, 5Hz - 2kHz. Analogous measurements were also made at a high frequency, 2 kHz - 400 kHz. At least three measurements were taken in each measurement point. The result is the arithmetic mean of these measurements.

Measurements were made with the electric and magnetic field meter ESM-100 (Fig. 2.). The ESM-100 performs measurements regardless of the antenna direction, i.e. isotropically. This is important in order to avoid errors because electric and magnetic fields are spreading from different directions and their values may continuously fluctuate. The measurements were taken in two frequency ranges isolated from each other: the first – 5 Hz - 2 kHz and the second – 2 kHz - 400 kHz.

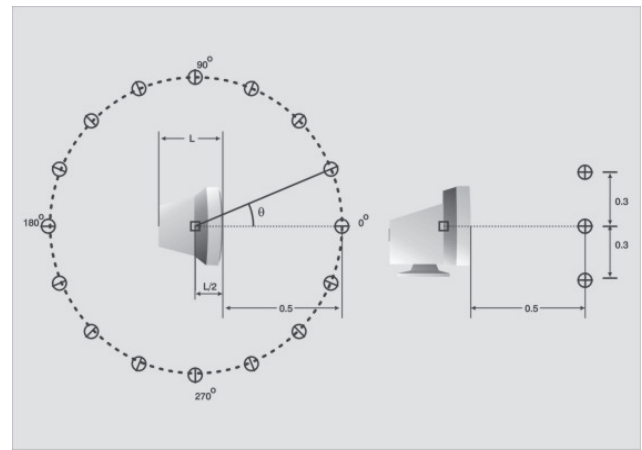

Fig. 1. Measurement scheme of electric and magnetic fields

An ESM-100 3D electric and magnetic field meter is a unique, patented, handheld measuring instrument. Frequency range from 5Hz – 400kHz, measuring range 1nT – 20mT and 0.1V/m - 100kV/m, display range 0nT - 20mT and 0,0V/m - 100kV/m for filter “50” or “16,7”, 10nT - 20mT and 1,0V/m - 100kV/m for filter “high” or “low”, 15nT - 20mT and 1,5V/m - 100kV/m for filter ‘all’. Liquid crystal display with illumination, H and E fields displayed simultaneously in 3 dimensional values. An ESM-100 3D electric and magnetic field meter was chosen considering to monitors frequency: power supply transformer range 50 Hz, pulsed power supply on a static converter range 20-100 kHz, frame distribution and synchronization block range 48–160 Hz, emission lines and block synchronization range 15–110 kHz.

Stronger electromagnetic fields in monitor's are created by electromagnetic coils which are equipped on a tube (electron gun) and are used to direct an image ray. The magnetic flux is generated by the monitor's transformer, line transformer and demagnetization loop.

Electromagnetic field modelling in a computer classroom

The initial (boundary) conditions for computer classroom electromagnetic field modelling are constructed by means of measured electric field strength and magnetic field density values in each of 16 points for all monitors. Values at (0°), (90°), (180°), (270°) positions are given in table 1 for LCD and CRT monitors correspondingly.

Table 1. Measured electric field strength and magnetic field flux density values for all monitors

Monitor No.	Electric field (5Hz – 2kHz) strength at (0°), (90°), (180°), (270°), V/m	Electric field (2kHz – 400kHz) strength, at (0°), (90°), (180°), (270°), V/m	Magnetic field (5Hz – 2kHz) flux density at (0°), (90°), (180°), (270°), nT	Magnetic field (2kHz – 400kHz) flux density, at (0°), (90°), (180°), (270°), nT
1	(9.8)(8.8) (7.6)(9.7)	(0.6)(0.8) (0.6)(0.6)	(180)(188) (173)(197)	(13)(13) (13)(14)
2	(10.2)(11.5) (14.0)(9.9)	(0.3)(0.3) (0.3)(0.3)	(163)(149) (189)(168)	(14)(14) (14)(14)
3	(13.6)(18.2)	(0.2)(0.2)	(76)(98)	(11)(11)

Monitor No.	Electric field (5Hz – 2kHz) strength at (0°), (90°), (180°), (270°), V/m	Electric field (2kHz – 400kHz) strength, at (0°), (90°), (180°), (270°), V/m	Magnetic field (5Hz – 2kHz) flux density at (0°), (90°), (180°), (270°), nT	Magnetic field (2kHz – 400kHz) flux density, at (0°), (90°), (180°), (270°), nT
	(12.9)(9.9)	0.2(0.2)	(88)(86)	(11)(11)
4	(14.1)(16.3) (13.7)(11.5)	0.3(0.3) 0.3(0.3)	(150)(168) (198)(145)	(12)(12) (12)(12)
5	(8.3)(9.5) (11.1)(10.0)	0.2(0.2) 0.2(0.2)	(78)(91) (86)(93)	(11)(11) (11)(11)
6	(12.5)(15.2) (16.0)(18.1)	0.2(0.2) 0.2(0.2)	(100)(123) (108)(143)	(12)(12) (12)(12)
7	(11.2)(15.9) (11.9)(9.0)	0.2(0.2) 0.2(0.2)	(174)(149) (183)(167)	(13)(13) (13)(13)
8	(17.4)(19.1) (20.7)(18.5)	0.2(0.2) 0.2(0.2)	(103)(132) (121)(109)	(11)(11) (11)(11)
9	(14.4)(17.3) (17.9)(16.3)	0.2(0.2) 0.2(0.2)	(98)(99) (70)(100)	(11)(11) (11)(11)
10	(14.9)(14.2) (17.9)(15.3)	0.3(0.3) 0.3(0.3)	(105)(109) (112)(148)	(32)(32) (32)(32)
11	(18.9)(22.0) (20.2)(15.9)	0.3(0.3) 0.3(0.3)	(223)(249) (133)(126)	(35)(35) (35)(35)
12	(17.3)(14.5) (17.9)(11.8)	0.3(0.3) 0.3(0.3)	(141)(179) (150)(134)	(35)(35) (35)(35)
13	(10.2)(15.8) (12.2)(14.6)	0.4(0.4) 0.4(0.4)	(263)(277) (289)(297)	(38)(38) (38)(38)
14	(16.3)(24.2) (21.0)(19.5)	0.4(0.4) 0.4(0.4)	(200)(202) (212)(199)	(37)(37) (37)(37)
15	(16.0)(17.1) (18.0)(16.1)	0.6(0.6) 0.6(0.6)	(210)(223) (240)(236)	(35)(35) (35)(35)
16	(13.9)(17.7) (14.8)(19.9)	0.5(0.5) 0.5(0.5)	(290)(288) (253)(296)	(38)(38) (38)(38)
17	(17.7)(18.1) (21.9)(17.8)	0.6(0.6) 0.6(0.6)	(265)(276) (254)(287)	(29)(29) (29)(29)
18	(12.3)(17.9) (16.0)(12.3)	0.3(0.3) 0.3(0.3)	(250)(246) (257)(250)	(47)(47) (47)(47)

Upon measuring electric field strength and magnetic flux density, a classroom is drawn with the software VIZIMAG and the baseline data of the electric and magnetic field are entered. A programme, which models electromagnetic fields in classroom is started. The lines of electric field strength and magnetic flux density are drawn and a model showing the classroom with all the monitors working is presented. In the places where the isolines intertwine, both the electric field strength and the magnetic flux density increase. The location and size of electric field strength or magnetic flux density can be identified according to presented colours and colour scale.

Statistical parameters were calculated to determine errors of the measured electromagnetic fields of computers.

The arithmetic average of the measurement data is closest to the actual value of the measured value

$$\bar{x} = \frac{\sum_{i=1}^n x_i}{n}, \quad (1)$$

where x_i – the result of the measurement i .

The standard deviation of the measurement data's arithmetic average is calculated according to the formula

$$s = \sqrt{\frac{\sum_{i=1}^n (x_i - \bar{x})^2}{n(n-1)}}. \quad (2)$$

The actual value of the measured quantity (X) is evaluated as follows

$$X = \bar{x} \pm s \cdot t, \quad (3)$$

where t – the Student coefficient, the quantity depends on the number and reliability level of the performed measurements.

The modelling programme VIZIMAG allows identifying the strength of electric field and the density of magnetic flux as well as the location thereof. Separate models are designed for both electric strength and magnetic flux density.

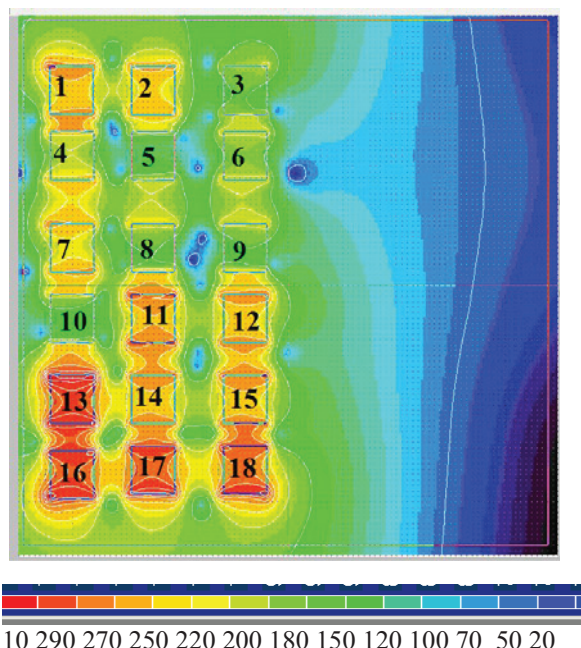
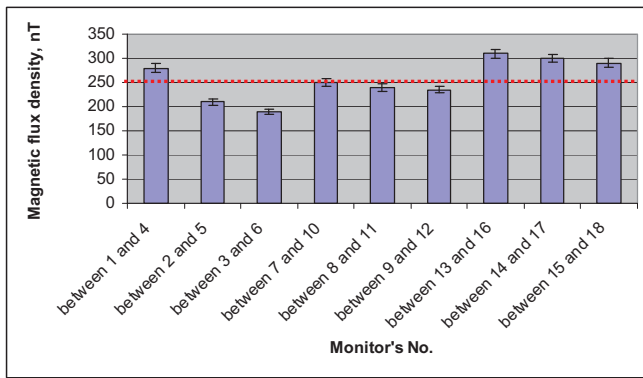

Fig. 2. Distribution of magnetic flux density in computer classroom at the frequency range 5 Hz – 2kHz

As Fig. 2 shows, distribution of magnetic flux density in a room is not uniform. The highest magnetic flux density is in the areas of the densest isolines. Magnetic flux density isolines are spread within the entire classroom; however, at a distance of 1 m from monitors magnetic flux density is weak and does not exceed the allowable norm 250 nT [11]. The highest magnetic flux density was measured next to tube monitors 15-18. The lowest magnetic flux density was recorded next to flat-screen monitors 3-10 (Fig. 3).

The average of magnetic flux distribution in the room reaches 150 nT. This room is dominated by a strong magnetic flux density, reaching up to 300 nT nearby tube monitors 13, 16, 17, 18 at the end of the classroom (red colour). The lowest magnetic flux density reaching up to 150 nT was recorded nearby flat-screen monitors 3, 4, 5, 6, 8, 9.



..... - Allowable hygiene norm

Fig. 3. Comparison of monitor magnetic flux density in the frequency range 5Hz – 2kHz

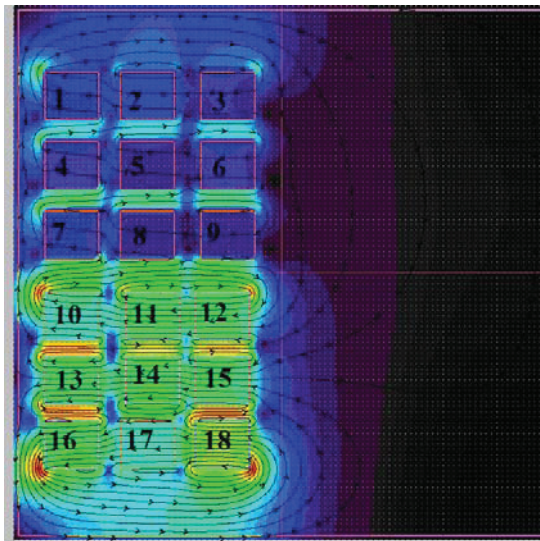

50 45 40 35 33 30 28 25 22 20 15 12 10 (nT)

Fig. 4. Distribution of magnetic flux density in computer classroom at the frequency range 2kHz – 400kHz

As Fig. 4 shows, the highest magnetic flux density is in the areas of the densest isolines. Magnetic flux density isolines are spread within the entire classroom; however, at a distance of 1 m from monitors magnetic flux density is weak and does not exceed the allowable norm 25 nT [11]. The highest magnetic flux density was measured next to tube monitors 10-18. The lowest magnetic flux density is next to flat-screen monitors 1-9 (Fig. 5).

The average of magnetic flux distribution in the room reaches 18 nT. This room is dominated by a strong magnetic flux density, reaching up to 50 nT next to tube monitors 12, 13, 14, 16, 18 at the end of the classroom (red colour). The lowest magnetic flux density reaching up to 11 nT was recorded next to flat-screen monitors 3, 4, 8, 9.

As Fig. 6 shows, the highest electric field density is in the areas of the densest isolines. The isolines of electric field strength are spread within the entire classroom; however, at a distance of 1 m from the monitors the strength of electric field is weak and does not exceed the allowable norm 25 V/m [11]. The highest strength of electric field was next to tube monitors 10-18. The least

electric field strength is next to flat-screen monitors 1-7 (Fig. 7.).

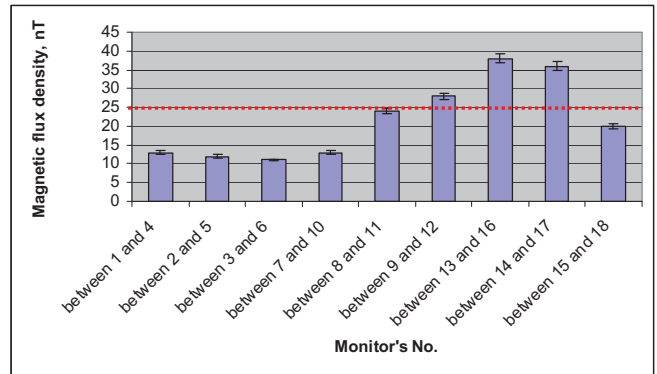

..... - Allowable hygiene norm

Fig. 5. Comparison of monitor magnetic flux density in the frequency range 2kHz -400kHz

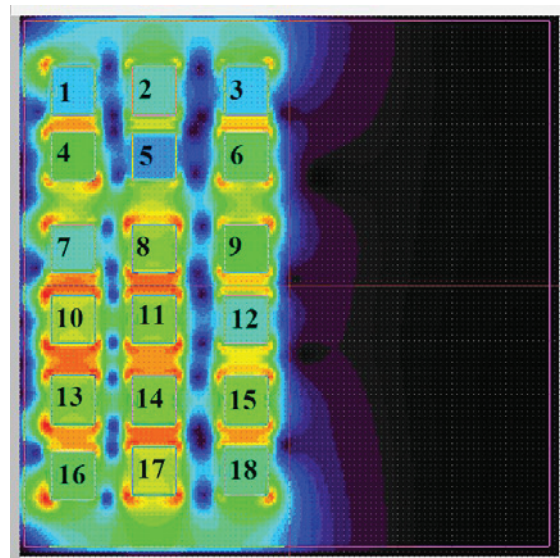

24 22 20 18 16 14 12 10 8 6 4 2 (V/m)

Fig. 6. Distribution of electric field strength in computer classroom at the frequency range 5 Hz – 2kHz

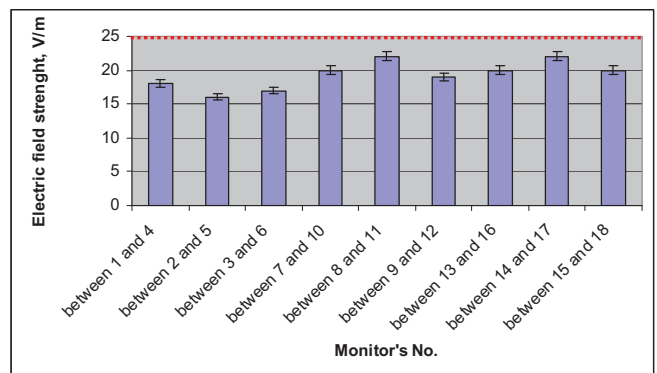

..... - Allowable hygiene norm

Fig. 7. Comparison of monitor electric field strength in the frequency range 5Hz – 2kHz

The average of electric field strength distribution in the room reaches 14 V/m. This room is dominated by a high strength of electric field reaching up to 24 V/m next to tube monitors 13, 16, 17, 18 in the middle of the classroom (red colour). The least electric field strength, up to 2 V/m, is next to flat-screen monitors 3, 4, 5, 6, 8, 9.

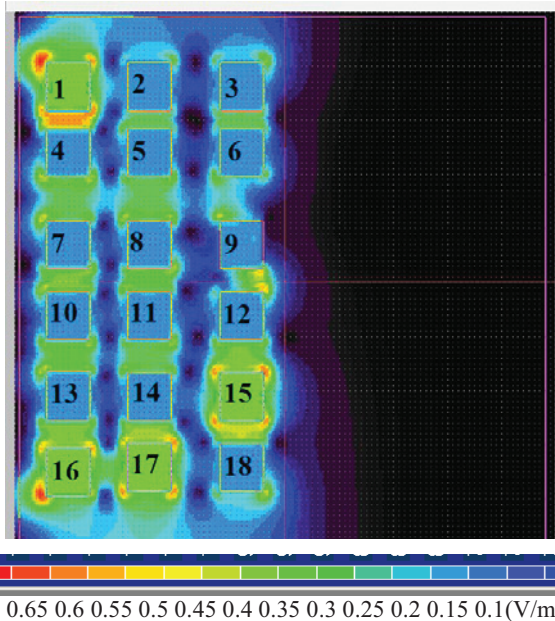

Fig. 8. Distribution of electric field strength in computer classroom at the frequency range 2kHz – 400kHz

As Fig. 8 shows, distribution of electric field strength in the room is not uniform. The isolines of electric field strength are spread within the entire classroom; however, at a distance of 1 m from the monitors the strength of electric field is weak and does not exceed the allowable norm 2.5 V/m [11]. The highest strength of electric field was next to flat-screen monitor 1 and tube monitors 16-18. The least electric field strength is next to flat monitors 1-7 (Fig. 9.).

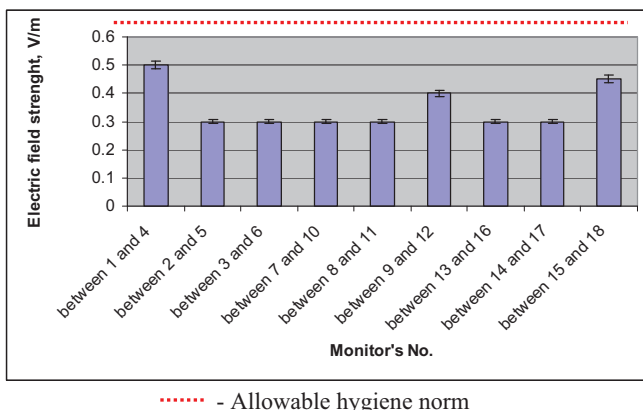

Fig. 9. Comparison of monitor electric field strength in the frequency range 2kHz – 400kHz

The average of electric field strength distribution in the room reaches 0.3 V/m. This room is dominated by a high strength of electric field reaching up to 0.6 V/m next

to tube monitors 15, 16, 17, 18 at the end of the classroom (yellow-red colour). The least electric field strength, up to 0.1 V/m, is next to flat-screen monitors 2, 3, 4, 5, 6, 7, 8, 9.

Conclusions

1. The electric field strength of all monitors in the range 5 Hz - 2 kHz varied from 2 V/m to 24 V/m; however, the allowable limit of 25 V/m was not exceeded in any of the monitors. Monitors do not generate a strong electric field in the frequency range 2kHz – 400 kHz with the maximum recorded strength of 0.7 V/m.

2. Tube CRT monitors exceed the maximum magnetic flux density limit of 250 nT in the frequency range 5 Hz – 2 kHz: the magnetic flux density of the thirteenth, sixteenth, seventeenth and eighteenth monitors is 310 nT. The strengths of magnetic fields propagated by LCD monitors are not exceeded.

3. The magnetic flux density of all tube CRT monitors in the frequency range 2kHz - 400 kHz exceeds the allowable limit of 25 nT, whereas the magnetic flux density of flat-screen LCD monitors does not exceed the allowable limit with its recorded maximum of 10 nT.

4. Monitors generate strong magnetic fields and weak electric fields in the frequency ranges 5 Hz - 2 kHz and 2kHz – 400 kHz.

5. Application of the software VIZIMAG ensure an exact modelling of the propagation of electric strength and magnetic flux density in a room.

References

1. **Morozionkov J., Virbalis J. A.** Influence of the Electric Reactor Magnetic Field on the Electromagnetic Relays // Electronics and Electrical Engineering. – Kaunas: Technologija, 2010. – No. 8(104). – P. 73–76.
2. **Dumčius A., Augutis V., Gailius D.** The Investigation of Magnetic Field Distribution in a Railway Rail Area // Electronics and Electrical Engineering. – Kaunas: Technologija, 2010. – No. 4(100). – P. 95–98.
3. **Morozionkov J., Virbalis J. A.** Investigation of Electric Reactor Magnetic Field using Finite Element Method // Electronics and Electrical Engineering. – Kaunas: Technologija, 2008. – No. 5(85). – P. 9–12.
4. **Tamošiūnaitė M., Tamošiūnas S., Daukšas V., Tamošiūnienė M., Žilinskas M.** Prediction of Electromagnetic Waves Attenuation due to Rain in the Localities of Lithuania // Electronics and Electrical Engineering. – Kaunas: Technologija, 2010. – No. 9(105). – P. 9–12.
5. **Jankauskas Z., Kvedaras V.** Elektrinio lauko ir srovės pasiskirstymas puslaidininkinėje plazmoje stipriame magnetiniame lauke // Elektronika ir elektrotechnika. – Kaunas: Technologija, 2007. – Nr. 2(74). – P. 41–44.
6. **Baltrėnas P., Fröhner K., Puzinas D.** Jūrų uosto įrenginių triukšmo sklaidos įmonės ir gyvenamojoje teritorijoje tyrimai // Environmental Engineering and Landscape Management. – Vilnius: Technika, 2007. – Nr. 2(15). – P. 85–92.
7. **Baltrėnas P., Buckus R.** Kopijavimo aparatų elektromagnetinių laukų tyrimai ir įvertinimas // Environmental Engineering and Landscape Management. – Vilnius: Technika, 2009. – Nr. 2(17). – P. 89–96.
8. **Baltrėnas P., Kazlauskas D., Petraitis E.** Triukšmo automobilių stovėjimo aikštelėse tyrimai ir jo sklaidimo skaitinis modeliavimas // Environmental Engineering and

- Landscape Management. – Vilnius: Technika, 2004. – Nr. 2(12). – P. 63–70.
9. **Baltrėnas P., Buckus R.** Biuro ir vaizdo įrangos elektromagnetinių laukų tyrimai ir įvertinimai // 11-oji Lietuvos jaunujų mokslininkų konferencija „Mokslas – Lietuvos ateitis“. – Vilnius: Technika, 2008. – P. 75–81.
10. **Vaišis V., Januševičius T.** 2008. Investigation and evaluation of noise level in the Northern part of Klaipėda city // Environmental Engineering and Landscape Management. – Vilnius: Technika, 2008. – No. 2(16). – P. 89–96.
11. **Techninė norma TN 01:1998 Displėjai.** Didžiausi leidžiami spinduliuojamo elektromagnetinio lauko lygiai. (Žin., 1998, Nr.58–1631).

Received 2010 10 26

P. Baltrenas, R. Buckus, S. Vasarevicius. Modelling of the Computer Classroom Electromagnetic Field // Electronics and Electrical Engineering. – Kaunas: Technologija, 2011. – No. 3(109). – P. 75–80.

Operation of office, video and audio equipment generates electromagnetic fields. Many employees who use computers for a long time complain of headaches and other health troubles. This has become a serious problem as electromagnetic fields are invisible and intangible and an employee, therefore, is unaware of how to protect oneself from them. This work involves modelling of the strengths of computer-generated electric and magnetic fields in the frequency ranges 5 Hz - 2 kHz and 2 kHz - 400 kHz in a computer classroom. After measuring the initial parameters of an electric and a magnetic field, electromagnetic fields propagating in the classroom were modelled with the help of the software VIZIMAG. Propagation and directions of electromagnetic field isolines are also presented. The modelling software VIZIMAG allows us to identify the strength of electric field or the frequency of magnetic field as well as the area of a room where they are present. Separate models are designed for both electric strength and magnetic flux density. III. 9, bibl. 11, tabl. 1 (in English; abstracts in English and Lithuanian).

P. Baltrėnas, R. Buckus, S. Vasarevičius. Kompiuterių klasės elektromagnetinių laukų modeliavimas // Elektronika ir elektrotechnika. – Kaunas: Technologija, 2011. – Nr. 3(109). – P. 75–80.

Veikiant biuro, vaizdo ir garso technikai susidaro elektromagnetiniai laukai. Daugelis darbuotojų, ilgai dirbančių kompiuteriais, skundžiasi galvos skausmais ar kitais negalavimais. Tai jau tapo didele problema, nes elektromagnetiniai laukai yra nematomi ir nejuntami, todėl darbuotojas nežino, kaip nuo jų apsisaugoti. Šiame darbe modeliuojami kompiuterių klasėje susidarantys elektriniai ir magnetiniai laukai 5 Hz–2 kHz ir 2 kHz–400 kHz dažnių diapazonuose. Išmatavus pradinis elektrinio ir magnetinio lauko parametrus, VIZIMAG programa sumodeliuojami visoje klasėje sklindantys elektromagnetiniai laukai. Pateikiami elektrinio lauko stiprio ir magnetinio srauto tankio linijų pasiskirstymo patalpoje vaizdai. Modeliavimo programa VIZIMAG leidžia nustatyti, koks kurioje patalpos dalyje yra elektrinio lauko stipris ar magnetinio srauto tankis. Kuriami atskiri tiek elektrinio lauko stiprio, tiek magnetinio srauto tankio modeliai. II. 9, bibl. 11, lent. 1 (anglų kalba; santraukos anglų ir lietuvių k.).