



IJRASET

International Journal For Research in
Applied Science and Engineering Technology



INTERNATIONAL JOURNAL FOR RESEARCH

IN APPLIED SCIENCE & ENGINEERING TECHNOLOGY

Volume: 6 Issue: VI Month of publication: June 2018

DOI: <http://doi.org/10.22214/ijraset.2018.6253>

www.ijraset.com

Call:  08813907089

E-mail ID: ijraset@gmail.com

Modelling, Simulation and Analysis of DC & AC Outputs using Hybrid PV and Wind Power System for Remote and Hilly Areas

Satyam Das¹, Pritam Debnath², Tushar Kanti Das³, Rajesh Debnath⁴, Sangita Das Biswas⁵

^{1,2,3,4} M.Tech, Department of Electrical Engineering,

⁵Assistant Professor of the Department of Electrical Engineering, Tripura University (A Central University) Suryamaninagar, Tripura, India, 799022

Abstract: One of the major challenge in the power generation is heavily depends of thermal power plant based on coal, at the same time for construction of coal based thermal plant there is restriction from environment aspects, so it is necessary to promote renewable energy like solar and wind energy generation. In case of installing the hybrid energy system, the main causes behind requirement of this installation is the intermittency of various energy resources and unbalanced quantity of sources of energies. The performances of solar PV and wind turbine connected hybrid generating systems are much better in conditions where the sunbeam and wind shifts their rate of availability based on the seasonal changes. A hybrid arrangement of combining the power harnessed from both the wind and the sun and stored in a battery can be a much more reliable and realistic power source. But, still the load can be powered through the energy stored in the batteries even when there is absence of solar or wind. Hybrid system is usually built for design of system with lowest possible cost and also with maximum reliability. The high cost of solar PV cell makes it less competent for larger capacity designs.

Keywords: Solar PV, Wind Turbine, MPPT, Rectifier, Inverter

I. INTRODUCTION

The proposed paper here a DFIG based wind turbine, a battery, and a solar PV array. The generated DC power from solar PV goes through an MPPT so that the maximum power could be determined. Then the DC power is sent to a boost converter. On the other hand, the AC power which is generated from the wind turbine is sent to an AC-DC converter from where the converted DC power is supplied to a line where the hybridization takes place between both the DC outputs from PV and wind system. At last the DC power is sent to the grid based on its requirement. The increasing use of DC appliances with the increase of penetration of solar PV, distribution of power in the DC form is become more attractive. In this project work what is done in the last stages that, the generating system is being divided into 2 parts, one is AC and other is DC. As this project is mainly focused on DC so, there is another option kept as AC source thinking about the much more present utilities of AC current in everyday life. Wind power depends on the sun; this is actually a form of solar energy. The air's heat and cooling causes wind circulation. Wind power systems are using the flow of air to generate mechanical energy through turbines, and then power for electric energy. It's like a fan in the reverse direction.

II. MATHEMATICAL EQUATIONS

Wind energy (PW) developed by the turbine is given by the equation,

$$P_w = \frac{1}{2} \rho (A_w) V^3$$

Where,

P_w is power having the unit watt.

ρ defines density in kg/m^3 of air.

A_w = swept area or swept area by air (m^2).

V = wind speed in m/s .

The total power generated by the solar panel is given by the equation,

$$P_{O(\text{solar})} = N_s \left(\frac{M \ln(V_0/M) + 0.72}{(1+M)} \right) (1 - R_s(V_0/I_{sc})) (I_{sc} G/G_0) \alpha_p (V_0 / (1 + \beta \ln(G_0/G))) (T_0/T)^p$$

Where,

C_p = Co-efficient of performance (< 0.5926),

v = wind speed (m / s),

η_g = generator efficiency (50%),

η_b = Gearbox bearing efficiency (90%),

V = voltage for open circuit,

N = Ideality factor ($1 < N < 2$),

K = Boltzmann constant (j / k) (1.38×10^{-23})

q = intensity of electron charge (e) (1.6×10^{-19})

R_s = series resistance (ohm),

I_{sc} = Short Circuit Current (A),

G, G_0 = solar radiation (w/m^2)

T, T_0 = temperature under the standard position (k)

α, β, β = constant parameters for PV module,

$M = (V_{oc} / (nkT / q))$

The method which is used in this Project to obtain the Maximum power point is incremental conductance method.

Here,

$dp/dv=0$ where $p=i*v$

$d(i*v)/dv= i + v*di/dt$

Hence, $i + v*di/dt = 0 = di/dv = -i/v$

In this case the error ($di/dv + i/v$) is minimized by the integral regulator.

Regulator Output = Correction of the Duty cycle.

Incremental behavioural algorithms of the system can be -

Step 1: Voltage and current from the PV panel are felt and is sent to the MPPT controller.

Step 2: The MPPT controller will compare the current value with the previous found values of the current and voltage, which will be the difference ΔI and ΔV .

$\Delta V = V_{new} - V_{old}$; $\Delta I = I_{new} - I_{old}$

Step 3: The maximum power point is tracked on the basis of $\Delta I / \Delta V$ slope.

Step 4: Addition of incremental conduction for immediate operation indicates error, $e = i / v + di / dv$.

Step 5: The error is sent to the PI controller to reduce the error or to run it on zero.

Step 6: The controller will produce duty ratio which will be sent to the comparator to make PWM pulses, the generated pulses will be sent to the switching device of the boost converter.

Step 7: The above steps will be repeated until maximum power is gained.

There are various types of MPPT techniques for PV and wind energy systems can be found. In case of PV some exemplary utilities can be, tracing the constant voltage, finding the maximum stable value, incremental conductance etc. MPPT techniques are often found to be utilised with DC to DC converter for turning ON or OFF the switch of boost converter. For a specific irradiance quantity, maximum power evaluated by either wind generator or PV system is found with the help of MPPT technique at the load. In case of solar PV generation perturb and observe method is used which is very much efficient, while in the other case, in wind generation system modified technique of perturb and observe method is being used.

III. PROPOSED MODEL DESCRIPTION

The proposed model of this project work depicts the combination of one solar PV generation and one wind power generation. In case of both the solar and wind system the MPPT concept is being utilized to find the maximum capable power transfer and to handle the controlling of DC-DC boost converter. In the hybrid system a freewheeling diode is used. There is a battery storage used to store the output. A battery electrolysing controller is introduced for the purpose of controlling the battery storage. At a particular condition, when wind or solar doesn't able to produce sufficient electricity, then the battery storage starts working as back up. The battery bank poses the capability to provide load for a certain period of time. The DC output is divided and sent to two sub ways, one goes as DC load which is further usable in DC utility equipments, on the other hand, the other portion is sent through inverter where DC to AC conversion takes place.

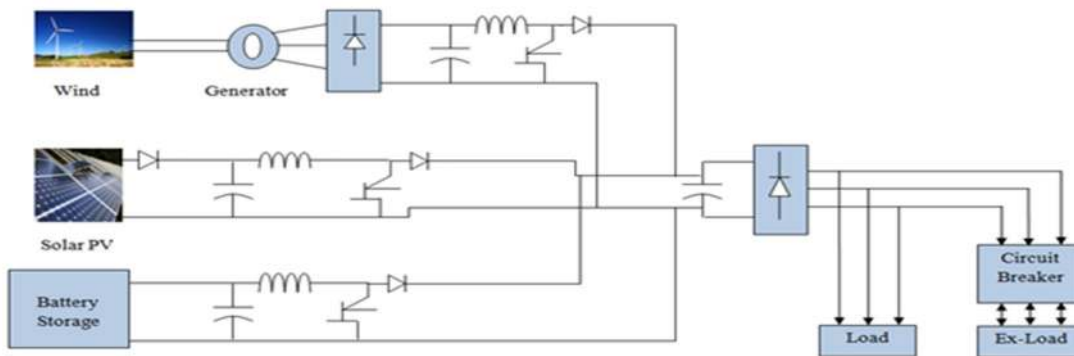

Fig.5.2.a: Proposed Hybrid system.

There is an inverter control circuit connected which provides protection against short circuit, excessive heating, low voltage and over load of the Inverter. The load generated here is divided into 2 parts; one is essential which will be supplied to the appliances in a direct method, another one is non essential which is sent through the circuit breaker when the value of essences load is exceeded from a critical limit. Thus the whole system works with combining both the wind and solar and resulting in DC and AC outputs. In later period the optimisation study is done using HOMER software for a remote or hilly area.

IV. MATLAB SIMULATION & RESULTS

The Simulation model was built and ran in three steps. At first the Simulink model of solar turbine and wind turbine were designed and then they were connected to result in a hybridized system.

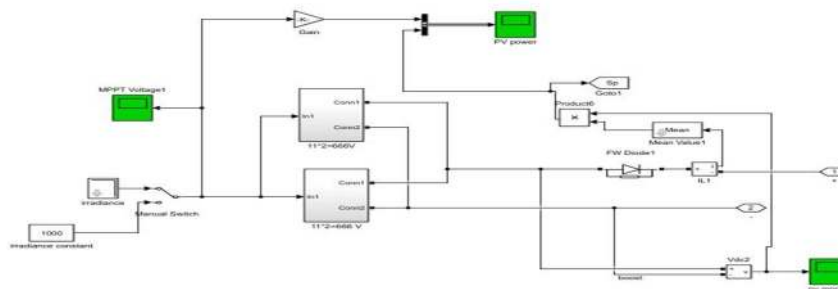

Fig: A PV model Simulation.

In the PV solar connection, the solar irradiance constant is taken as 1000. Now from necessary voltage is 660 volt. So, here at first 2 modules are used having 336 volt each. Then these 2 modules are connected in parallel and the generated output is again connected in series with another similar module. A freewheeling diode is connected to a current measurement unit. The voltage is measured from the PV-MPPT and then both the values of current and voltage are compiled to find the value of power generated from the Solar PV system.

A. Solar PV Simulation Results

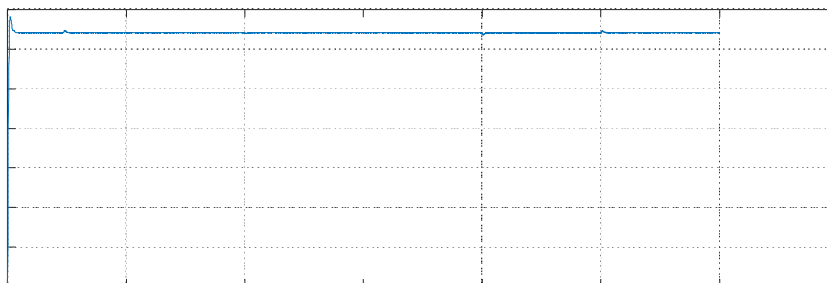

Fig: PV MPPT Voltage with respect to time.

The above figure shows the generation of voltage from the PV-MPPT. At first there a sudden change can be observed, but after a while the graph gets its stable value.

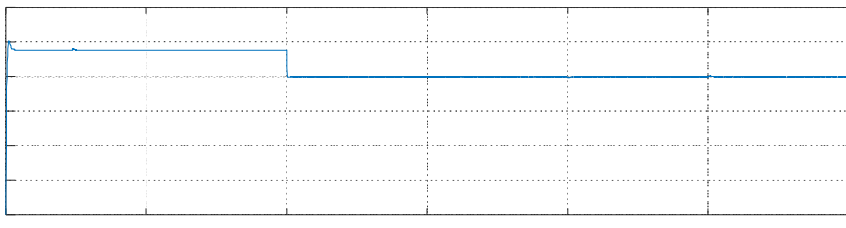

Fig: PV Power output.

From this figure it is found that after 2seconds from the starting of the simulation the value reduces and gets its stable state.

B. Wind Generation System

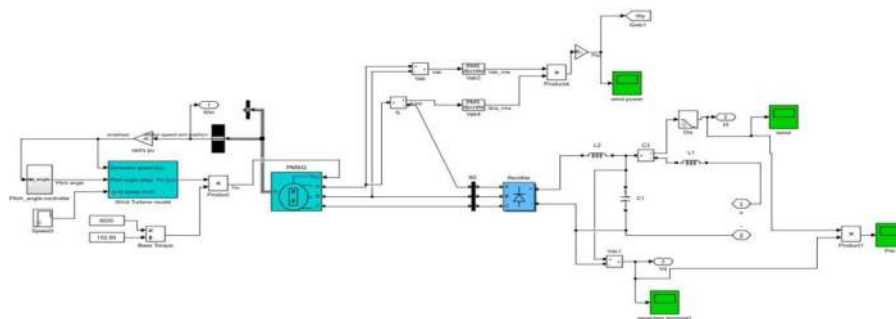

Fig: Wind power model in MATLAB simulation.

In case of wind generation as the wind speed varies at different times of a day, so a permanent magnet synchronous generator is used. The actual value of required torque is gained by multiplying the per unit value with base value. Pitch angle controllers are used for controlling the blade angle of the turbine. AC is generated from the system and then it is sent through the rectifier to be converted into DC. There is a low pass filter used to minimise the distortions and harmonics. The output found from the system is farther sent to the next stage where the 2 ports of the output will be connected to the main model. Another connection is there which will be directly sent as AC output to compare the value with the DC.

C. Wind Power Simulation Results

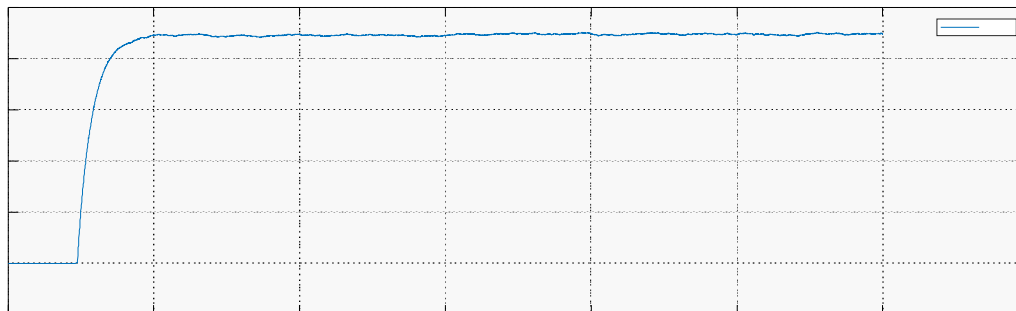

Fig: Wind DC power using rectifier.

In the above figure the DC power generated from the wind is shown. It is clearly visible that after reaching the point of completion of the 1st second the output voltage becomes stable and hence it continues forward.

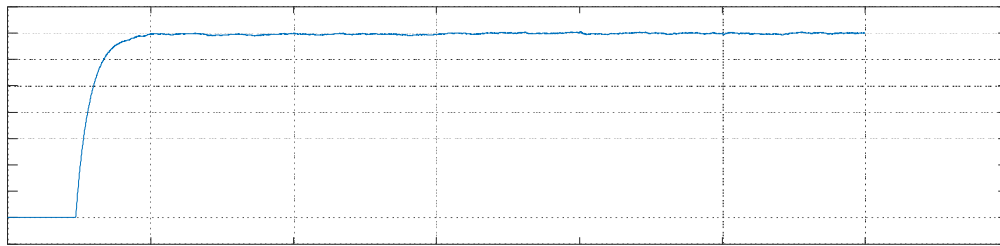

Fig: Wind current output Graph

Here also like the pervious image, the current is generated and it takes a few times to reach its stable value. After that state the value remains constant for the next 5 seconds.

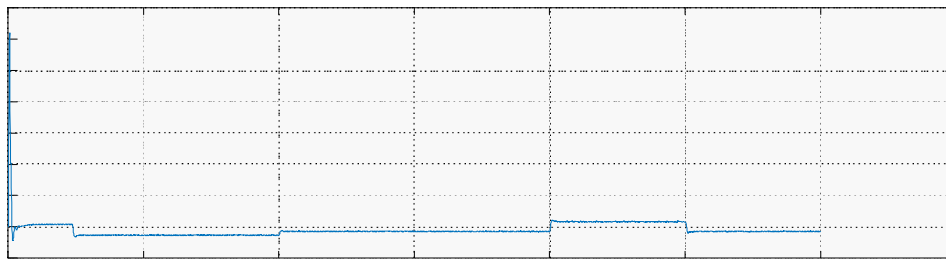

Fig: Wind Mean Output

The generated graph here gives an idea about the mean output voltage of the wind turbine. It shows how the value changes with the change of time.

D. Simulation Model of Hybrid Solar and Wind Generation System

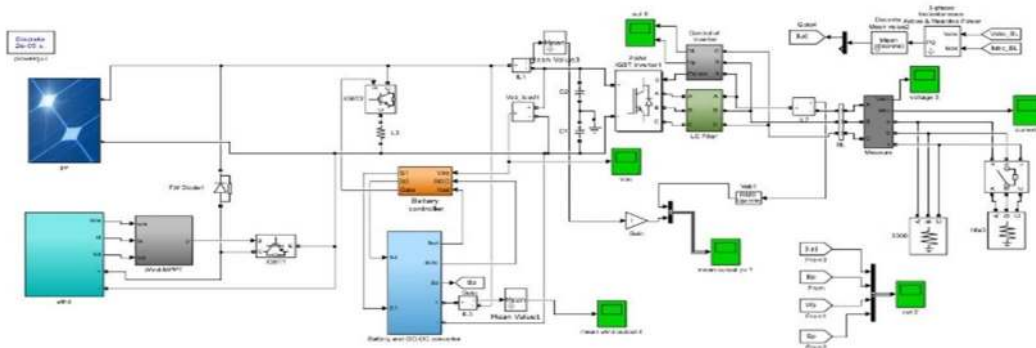

Fig: Matlab Simulation of Hybrid Solar & Wind.

From the figure it is observable that the hybrid system is being developed with combining the Wind and Solar PV generation here. At previous stages the wind and solar simulation diagrams were designed. An MPPT and a freewheeling diode are connected to the wind turbine. Here, the freewheeling diode can be found connected with both the solar and wind outputs, so that if one system fails to serve the whole process of energy generation doesn't stop. Two IGBTs are connected through the system with both the generating systems. There is one Battery storage connected to both the wind and solar output and another battery charge controller is there which acts as the control unit of the battery. There is a DC-DC boost converter connected to the battery storage and a current measurement unit is connected to the output of the storage device which will measure the mean value of the current. From the battery charge controller the mean value of voltage is measured with a voltage measurement unit and also there is another current measurement unit to find the current value. A low pass filter is connected to the output DC so that the distortions and harmonics of the output signal can be reduced.

E. All Three Phase Supplies after Using Low Pass Filter

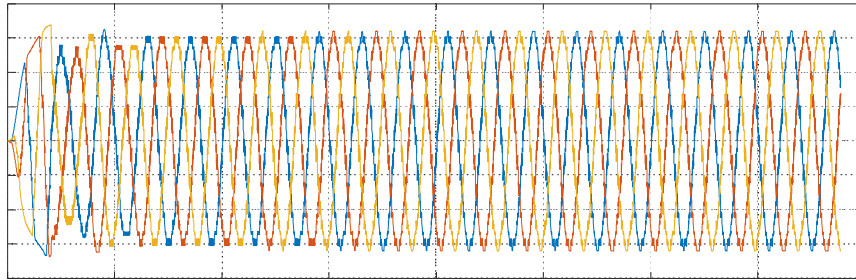

Fig. Three Phase Load current

The figure above depicts the graphical representation of the load current measured from the three phase line. It shows that the AC current here lies between particular ranges.

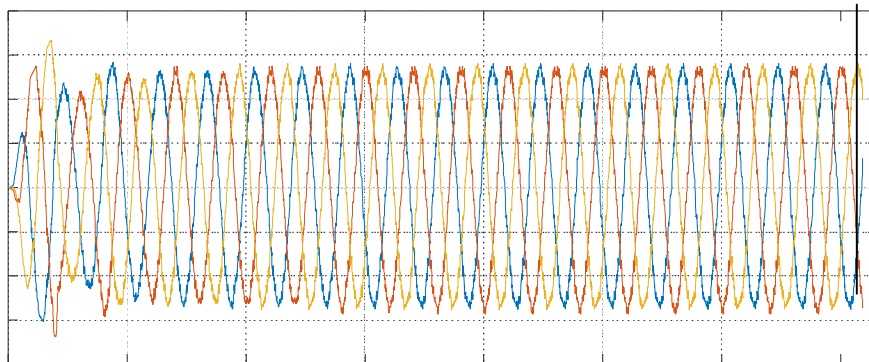

Fig. Three Phase supply Voltage

It is also as same as the previous graph. The graph in this figure shows the three phase AC supply voltage range in the system.

F. Final Load Power Output

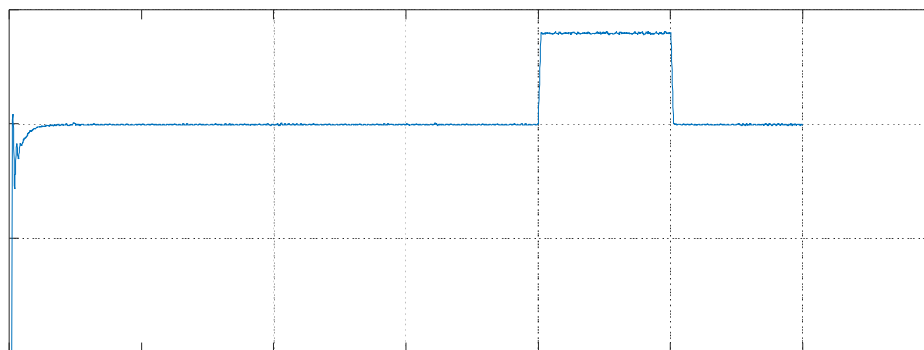

Fig. The Output Load Power (10kW)

In this figure the output load power is shown with a maximum range of 10kW. If it is observed it can be determined that from the 4th to the 5th second of the time period the load exceeds the limit and as a result of that the circuit breaker gets turned on. And at that particular time the load passes through the circuit breaker as non essential load which can be utilised further or be distributed to the grid.

G. The Output of the Matlab Simulation

TABLE: 1

Solar PV	
MPPT Voltage	641.35 Volt
The Generic Power	8 kW

TABLE: 2

Wind power Generation	
Wind generator Voltage	640.35 Volt
The Generic Power output	7.99 kW

TABLE: 3

Control of converter:	
Three phase Line to Line Voltage (V_{L-L} , Voltage)	244.1volt, -567volt, 323volt
Three phase rms Voltage (V_{Phrms} , Voltage)	221.9volt, 221.9volt, 221.7volt

TABLE: 4

Power Outputs:	
Wind Power (Wp)	7998 Watt
Solar Power (Sp)	7985 Watt
Load power (Lp)	9959 Watt
Battery Power (Bp)	1517 Watt

VI. CONCLUSION & FUTURE SCOPE

In remote and hilly areas, there always lies a crisis of good amount of solar and wind energy. At a time, either wind can be found as source or sunbeams can be observed. So if these two energies can be combined together then they can produce a good impact. Compared to AC, DC consumes less energy. So, if the systems utility module is run by DC then it may be much more power saving process. The system that was designed here gives more importance to the DC generation though AC also comes into act. Under all the operating conditions for meeting the load the hybrid system has been controlled to provide the output power at its maximum level. The battery storage and control system was connected to support the uninterrupted supply in load power if one of these two generating systems fails and also as back up supplier of power.

VII. ACKNOWLEDGEMENT

We would like to express our deepest gratitude to our academics and advisors for her guidance and constant support in helping us to proceed our work. We would be grateful to all the other staff members of Department of Electrical Engineering for their extended co-operation and assistance. At last, we would like to express our vote of thanks to all of our group members for their enthusiasm and equal support rendered directly or indirectly and creating an atmosphere that was very positive and pleasing to carry out the whole work.

REFERENCES

- [1] Tao Ma, Xongxing Yang, "A feasibility of a stand-alone hybrid solar-wind battery system for a remote island". IEEE. 2014. Pg.149-158
- [2] Subhadeep Bhattacharya, Shantanu Acharya, "PV-wind hybrid power option for low wind topography". Energy conversion and management, 2015, Pg. 942-954
- [3] . Prashant Rama, N. Rajashekhera, "Design and review of maximum power point tracking techniques in wind and solar photo voltaic system", A review renewable and sustainable energy reviews. 73. 2017. Pg.1138-1159
- [4] Yabin Bouzelata, Neemi, Rachid Chenni. "Exploration of optimal design and performance of a hybrid wind solar energy system". Energy conversion and management 89. 2015. Pg.1142-1154
- [5] Sunada Singh, G.S Chandel, "Prospect of solar photo voltaic micro-wind based hybrid power system in western Himachal Pradesh in India". Energy conversion and management. 105. 2015. Pg. 1340-1351.



- [6] Anjali Rana, Mahammad Jivas, "Implementation of a wind/solar hybrid system using MATLAB Simulink". IJAREE. Vol.4. Issue 7. 2015.Pg. 725-73
- [7] Rajesh K., A.D Kulkarni, "Modelling and simulation of solar PV and DFIG based wind hybrid system", Procedia Technology. 21. 2015. Pg.667-675.
- [8] S. Chandrashekher, K. Raghu Ram, "Modelling and control MPPT based grid connected wind- PV hybrid generation system", INNS. Vol. 4, issue 1.2017.Pg.2279-2353.
- [9] T. Sripal, B. Anuradha. "Modelling and simulation of solar-PV Hybrid generation system for induction motor drive application". 21. 2015. Pg.198-208.
- [10] Chirag Gorani, V.R. patel, "Performance analysis of grid connected hybrid wind/PV system", IRJET Volume04, issue 04. Apr2017. Pg. 300-307.
- [11] R. Dave, Manish N. Sinha, "Simulation of solar and wind Power Plant Using MATLAB for Micro-Grid", FJRASET. Vol-1, 2017, Pg. 208-213.
- [12] Rajesh Kunat, Prabhjot Kaur, "Low voltage DC distribution –are we ready yet?" IIT, Madras. 2016. Pg. 8-13.
- [13] Girish Makarbhi, Vinay Gavade. "Compatibility and performance study of home appliances in a DC home distribution system". IEEE. 2014. Pg. 110-117.
- [14] Pertti Paaajanen, Tero Kaipia, "DC supply of low-voltage electricity appliances in Residential building". 2009. Pg.8-11.
- [15] Venkat Rajarman, Ashok Jhunjhunwala, "Economic Analysis of Deployment of DC power and appliances along with solar in urban multi-storied buildings". IEEE. 2015. Pg. 32-37
- [16] Pooja Rani,Vignesh D., "Design of converters for developing 48V DC power line at Home/Offices", IEEE. 2016. Pg. 152-157.

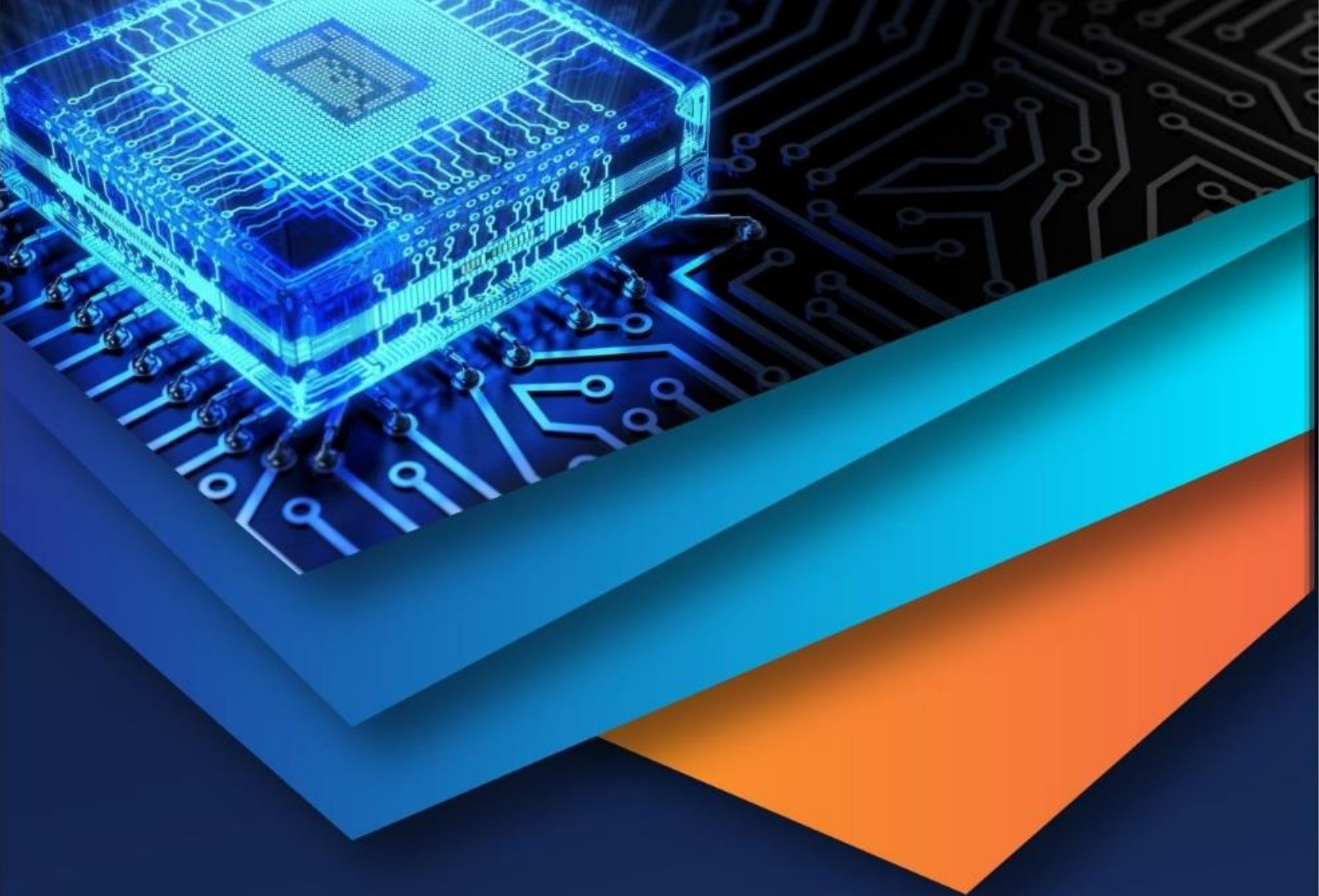

10.22214/IJRASET



45.98



IMPACT FACTOR:
7.129



IMPACT FACTOR:
7.429



INTERNATIONAL JOURNAL FOR RESEARCH

IN APPLIED SCIENCE & ENGINEERING TECHNOLOGY

Call : 08813907089  (24*7 Support on Whatsapp)