

Models for Understanding

Richard E. Mayer

University of California, Santa Barbara

What can be done to empower students to be creative when they are faced with problems? One promising instructional technique for improving students' understanding of scientific explanations is the use of conceptual models. This review examines three predictions concerning the effects of conceptual models on students' understanding of scientific prose: that models improve recall of conceptual information, decrease verbatim retention, and increase creative solutions on transfer problems. In a review of 20 studies involving 31 separate tests, results consistently indicated that models can help lower aptitude learners to think systematically about the scientific material they study.

Why is it that some people, when they are faced with problems, get clever ideas, make inventions and discoveries? What happens? What are the processes that lead people to such solutions? What can be done to help people to be creative when they are faced with problems? (Luchins & Luchins, 1970, p. 1)

When the great Gestalt psychologist, Max Wertheimer, proposed these questions to his seminar students in 1936, no one responded. Indeed, in Wertheimer's day there was not a sufficient research base to provide the illuminating answers that these challenging questions deserved. In the half century that has elapsed, and particularly in the last decade, however, cognitive theories of learning and transfer have emerged that may be able to shed more light (Ausubel, 1968; Cormier & Hagman, 1987; Gentner & Stevens, 1983; Mayer, 1987a; West & Pines, 1985).

The goal of this review is to examine one promising technique for helping students to learn new material in ways that allow them to be creative when faced with problems. In particular, this review examines the usefulness of providing conceptual models as aids to students' understanding of scientific explanations. For purposes of this review, a conceptual model is defined as words and/or diagrams that are intended to help learners build mental models of the system being studied; a conceptual model highlights the major objects and actions in a system as well as the causal relations among them.¹ For purposes of this review, understanding refers to a student's ability to creatively use presented information to solve transfer problems.

For example, suppose that we asked some students to read a passage about radar. What can we do to help students learn about radar in ways that will enable them to use what they have learned to generate creative solutions to transfer problems? In short, we want our students to be able to answer questions that were not part of the lesson, such as, "How can you increase the area under radar surveillance?" One relatively modest instructional manipulation that might help is to provide a diagram, such as in Figure 1, that spells out the major objects (such as transmitter, receiver, pulse, remote object, etc.) and major actions (such as transmission, reflection, reception, etc.) in a radar system and that shows the causal relations among actions.

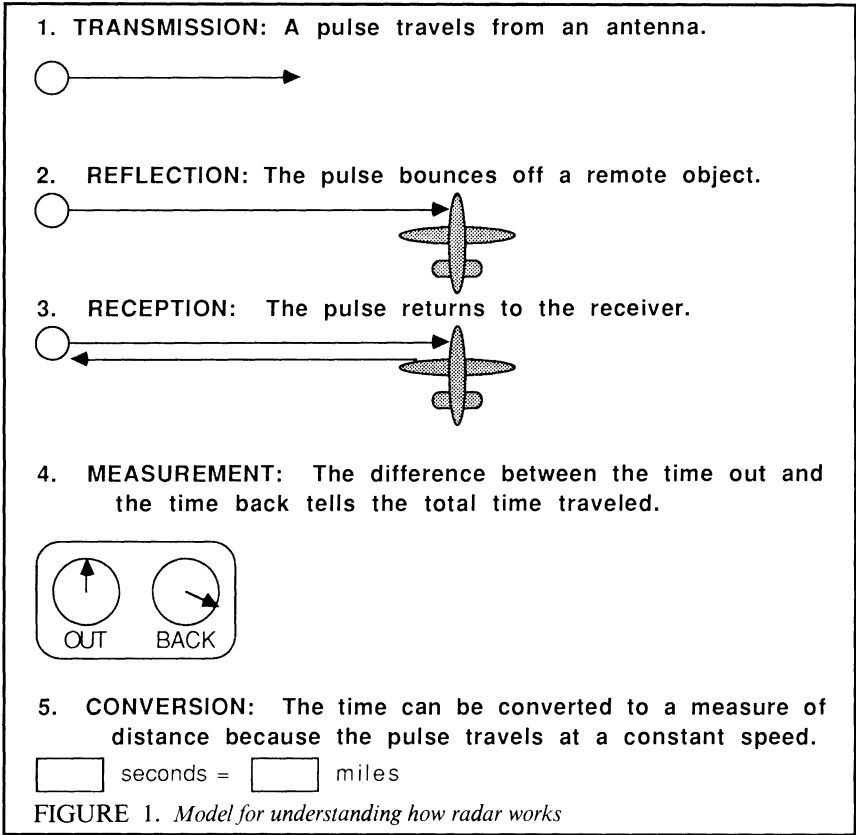

A Model of Meaningful Learning

In order to conduct this review on models for understanding, it is first necessary to outline the relevant components in the teaching/learning process: learner characteristics, learning material, instructional method, learning processes, learning outcome, and performance. These components are summarized in Figure 2.

Learner characteristics: Novices. Learner characteristics refer to the preexisting knowledge and capacities that the learner brings to the learning situation. For the purposes of this review, I focus on novices rather than experts, that is, on students who lack prerequisite knowledge and capacities for the subject domain. These less skilled students are most likely to benefit from direct instruction in how to construct a conceptual model for the to-be-learned material, whereas more skilled students are likely to already possess and spontaneously use sophisticated conceptual models that may conflict with models presented during instruction.

To-be-learned material: Systems. The to-be-learned material is the subject-matter content that is presented for the student to acquire. For purposes of this review, I focus on explanative material (Mayer, 1985, 1987b), that is, on material that explains how some system works. A system is a coherent collection of parts that interact (Simon, 1969). Examples include technological devices such as radar

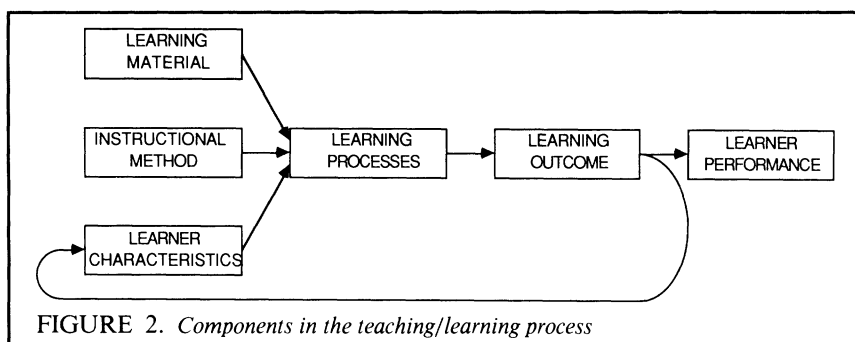

systems, cameras, and braking systems; scientific explanations such as the nitrogen cycle, Ohm's law, or the concept of density; and programming languages such as BASIC or data management systems. Explanative material allows students to think systematically, that is, to build and use models that explain the information. I have focused this review on explanative material because meaningful methods of instruction can only have an effect for learning of material that is potentially meaningful. Unfortunately, much of the material in science textbooks does not meet this criterion (White & Mayer, 1980). The left column of Table 1 lists the topics that were taught in the studies included in this review.

Instructional method: Models. Instructional method refers to the way in which the material is presented to the student. For purposes of this review, I focus on one promising technique for fostering meaning learning of the material, namely, the use of conceptual models that spell out the major parts, states, and actions in

TABLE 1
Some topics, models, and measures of scientific explanation

Topic	Model	Example transfer problem
Radar	Figure 1	How can you increase the area under radar surveillance?
Ohm's law	Figure 5	How is resistance like pushing a wheelbarrow up a ramp?
Density	Figure 6	If heat applied to an object increases its volume, what happens to the density of that same object when it is heated?
Data base	Figure 7	Tell the problem that is solved by a given program.
BASIC	Figures 8 & 12	Tell what task is accomplished by a given program.
Nitrogen cycle	Figure 9	If you used only natural means, how could you make the soil richer in nitrogen for use by plants?
Camera	Figure 10	How would you set a camera to take a picture of a pole vaulter on a cloudy day?
Brakes	Figure 11	What could be done to improve the reliability of brakes?

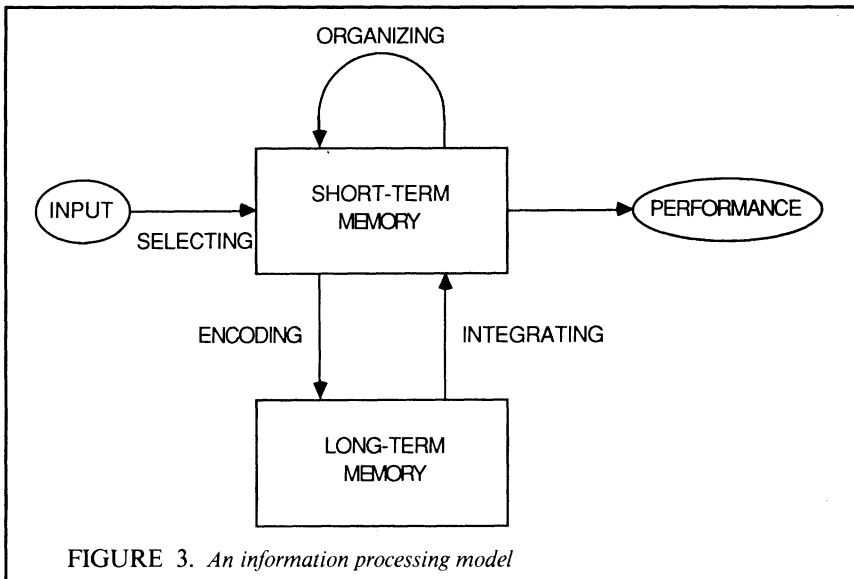

FIGURE 3. *An information processing model*

systems. In reviewing research, I include studies that compare students who learn with the aid of a conceptual model (model group) with students who learn the same material without a model (control group). I focus on conceptual models because recent theories of analogical transfer have pointed to the crucial role of models in enabling transfer (Curtis & Reigeluth, 1984; deKleer & Brown, 1981, 1983; Gentner, 1983; Hayes & Henk, 1986; Royer & Cable, 1976). The second column of Table 1 describes models used in the studies included in this review. In each case, the model is a text and pictorial representation of the explanative information in the passage; it highlights the key concepts from the text and suggests relationships among them.

Learning processes: Selecting, organizing, and integrating. Learning processes refer to the way in which students encode to-be-learned information. The mode of instruction is intended to affect the way that students select, organize, and integrate information (Mayer, 1984). In this review, I focus on three specific processes: models are expected to guide students' selective attention toward the conceptual information in the lesson (i.e., the major objects, states, and actions, and the causal relations among them), to organize the information around coherent explanations (i.e., build internal connections), and to integrate the information with existing relevant knowledge (i.e., build external connections). Appendix A summarizes definitions and examples from the radar passage of these types of cognitive processes, and Appendix B elaborates on the examples.

Figure 3 shows an information processing model for describing meaningful learning processes. The boxes in the model refer to short-term (or working) and long-term memory stores; the arrows refer to processes, including selecting information to pay attention to (i.e., arrow from input to short-term memory), organizing incoming information in short-term memory (i.e., arrow from short-term memory to short-term memory), integrating prior knowledge from long-term

memory with incoming information (i.e., arrow from long-term memory to short-term memory), and encoding the resultant learning outcome in long-term memory (i.e., arrow from short-term memory to long-term memory).

Learning outcomes: Understanding. The outcome of learning refers to the knowledge that the student acquires as a result of the learning processes. Students given model instruction may be more likely to build mental models of the systems they are studying and to use these models to generate creative solutions to transfer problems. In short, these students may be better able to engage in systematic thinking. In each study reviewed in this paper, the transfer test involves answering questions that go beyond both the passage and the model.

Figure 4 summarizes the conditions for building meaningful learning outcomes. As can be seen, meaningful learning requires that students attend to relevant information, build internal connections among the pieces of information, and build external connections between the information and relevant existing knowledge. For example, in the radar example, the relevant information involves the parts—such as transmitter, receiver, remote object, and pulse—and processes—such as transmission, reflection, and reception. (Examples of internal and external connections for the radar lesson are listed in Appendix B.)

Performance: Systematic thinking. Performance refers to what the student can do as a result of learning. In this review, I focus on three specific performance indicators of systematic thinking: recall of conceptual information, retention of the information in nonverbatim format, and generation of creative problem solutions. The right portion of Table 1 lists some creative transfer questions used to evaluate systematic thinking.

Research on text illustrations has provided some empirical evidence that students retain more information from expository text passages that include illustrations than from text without illustrations (Alesandrini, 1984; Anglin & Stevens, 1986; Curtis, 1988; Curtis & Reigeluth, 1984; Dean & Enomoto, 1983; Levie & Lentz, 1982; Levin & Berry, 1980; Levin & Lesgold, 1978; Readence & Moore, 1981; Reid & Beveridge, 1986; Reid, Briggs, & Beveridge, 1983; Rusted, 1984; Rusted & Coltheart, 1979a, 1979b; Rusted & Hodgson, 1985; Saroyan & Geis, 1988; Schallert, 1980). Research on text illustrations, however, generally has not focused on cognitive analyses of students' learning and thinking processes as measured by dependent measures that go beyond overall amount retained, except in studies that measure students' inferences (e.g., Holmes, 1987). Correspondingly, research on mental models has provided some theoretical contributions concerning how a person's knowledge may affect their problem-solving performance but generally has not focused on empirical work related to instructional issues (Gentner & Stevens, 1983; Michalski, Carbonell, & Mitchell, 1986). Consequently, this review requires bridging the gap between the educational relevance of research on text illustrations and the theoretical relevance of research on mental models.

In summary, this review examines published research studies—all conducted over the past 15 years in my laboratory—that meet four criteria. First, the learners must be novices rather than experts. Second, the to-be-learned material must be explanative rather than descriptive or narrative. Third, the major independent variable must be whether conceptual models are used as aids to instruction. Fourth, the major dependent measures must be recall of conceptual information, retention of material in verbatim format, and/or creative problem-solving transfer perform-

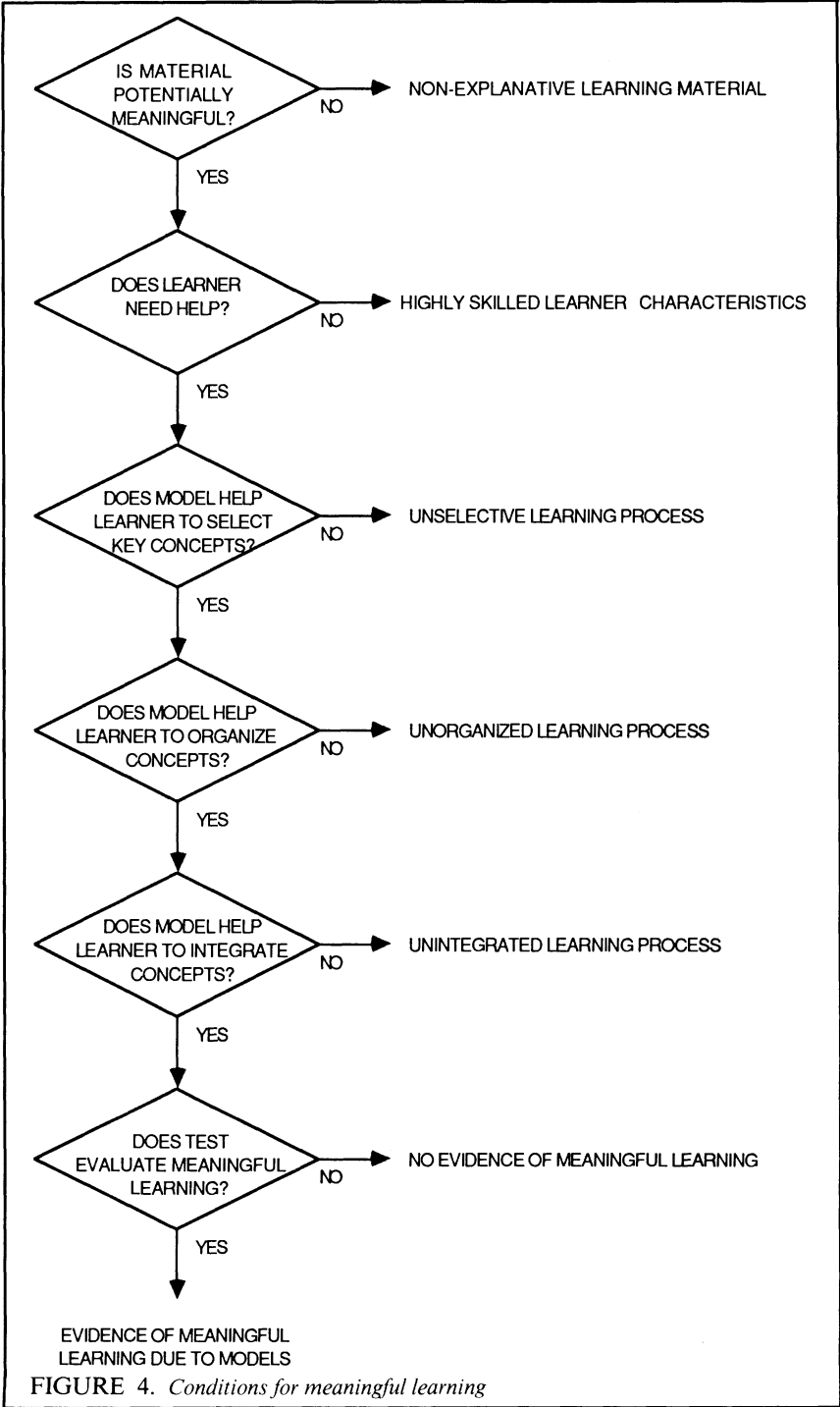

FIGURE 4. Conditions for meaningful learning

ance rather than the more traditional measures of overall amount recalled and/or overall performance on comprehension tests.

Finally, this review examines three specific predictions based on the foregoing analysis of learning processes and outcomes. First, model students should recall more conceptual information than control students. This prediction follows from the idea that models guide students' selection of material for learning. Second, model students should be less likely to retain the material in verbatim form as compared to control students. This prediction follows from the idea that models encourage students to reorganize and integrate the acquired information. Third, model students should generate more creative solutions to transfer problems than control students. This prediction follows from the idea that students who have built useful mental models will be better able to make novel inferences by "running" (deKleer & Brown, 1981) their models.

Research on Models for Understanding

Model Before the Lesson

This section reviews a series of studies in which a conceptual model was presented prior to a lesson, as summarized in the top portion of Table 2.

Radar. In a recent study (Mayer, 1983, Experiment 1), students listened to a 640-word lecture on how radar works, adapted from *The Encyclopedia of How It Works* (Clarke, 1977). Prior to hearing the lecture, some students had 1 minute to examine a model sheet, as shown in Figure 1, whereas other students did not. Although the information in the model was redundant with information in the lecture, the model served to highlight and organize the main steps and elements in radar processing as had been determined in previous analyses (Mayer & Cook, 1980). For example, the model used a set of five concrete diagrams to represent the five major steps in radar processing: transmission, reflection, reception, measurement, and conversion. In addition, the model concretized the major elements in the system: the radar pulse, the remote object, the transmitter, the receiver, the clock, and the converter. Consistent with our predictions that model training would elicit systematic thinking, the model students recalled 57% more of the conceptual information, scored 14% lower in verbatim retention, and generated 83% more correct answers on problem-solving transfer as compared to control students.

Ohm's law. In a similar study (Mayer, 1983, Experiment 2), students listened to a 390-word lecture on Ohm's law taken from a high school physics textbook (Herron, Palmer, & Joslin, 1972). Prior to hearing the lecture, some students were given 1 minute to examine a model sheet, as shown in Figure 5, whereas other students were not. The model consisted of four labeled diagrams that emphasized the major elements and states in electrical flow as identified in previous analyses of the major concepts underlying Ohm's law (White & Mayer, 1980). In particular, the diagrams provided models for concretizing the concepts of circuit (i.e., a battery, a bulb, and connecting wires allow continuous electrical flow), potential difference (i.e., a battery produces negative and positive particles), current (i.e., electrons flow through a wire), and resistance (i.e., obstacles in a wire slow electrical flow). The model is similar to some aspects of the *flowing water* and *teeming crowd* analogies used by Gentner and Gentner (1983) to help students understand the concept of electrical flow. As predicted, the model students recalled 120% more of the conceptual information than the control students.

TABLE 2
Summary of research on models for understanding

Topic	Source	Type of test (%)		
		Conceptual recall	Verbatim retention	Creative problem solving
Model before the lesson				
Radar	(Mayer, 1983, Exp. 1)	+57	-14	+83
Ohm's law	(Mayer, 1983, Exp. 2)	+120	—	—
Density	(Mayer, Dyck, & Cook, 1984, Exp. 1)	+144	-26	+45
Data base	(Mayer, 1980, Exp. 1)	—	—	+92
	(Mayer, 1980, Exp. 4)	—	—	+129
	(Mayer, 1980, Exp. 5)	+26	—	—
BASIC	(Mayer & Bromage, 1980, Exp. 1)	+43	—	—
	(Mayer & Bromage, 1980, Exp. 2a)	+44	—	—
	(Mayer & Bromage, 1980, Exp. 2b)	+30	—	—
	(Mayer, 1976, Exp. 1a)	—	—	+245
	(Mayer, 1976, Exp. 2a)	—	—	+100
	(Mayer, 1976, Exp. 2b)	—	—	+132
Model within the lesson				
Nitrogen cycle	(Mayer, Dyck, & Cook, 1984, Exp. 2)	+73	-14	+42
Camera	(Bromage & Mayer, 1981, Exp. 2)	—	—	+29
Brakes	(Mayer, in press, Exp. 1)	+46	-5	+61
	(Mayer, in press, Exp. 2)	+23	-8	+65
BASIC	(Mayer, 1975, Exp. 1a)	—	—	+64
	(Mayer, 1975, Exp. 1b)	—	—	+460
	(Mayer, 1985, Exp. 2)	—	—	+52
	(Mayer, 1976, Exp. 1b)	—	—	+33
	(Bayman & Mayer, 1988, Exp. 1)	—	—	+21

Note. Scores indicate percentage differences between control and experimental groups based on the formula (experimental – control)/control. Dashes (—) indicate that no measure was taken.

Density. Mayer, Dyck, and Cook (1984, Experiment 1) asked students to read a 450-word passage on density that was representative of high school physics textbooks. Prior to reading the passage, some students were given a model sheet, as summarized in Figure 6, whereas other students were not. The model showed a diagram of a cube of city air along with a verbal definition of volume and a diagram showing particles in a cube of city air along with a definition of mass. Thus, the model helped concretize the concept of volume as a three-dimensional container and mass as the amount of material in the container. As predicted, the model students recalled 144% more of the conceptual information, scored 26% lower on

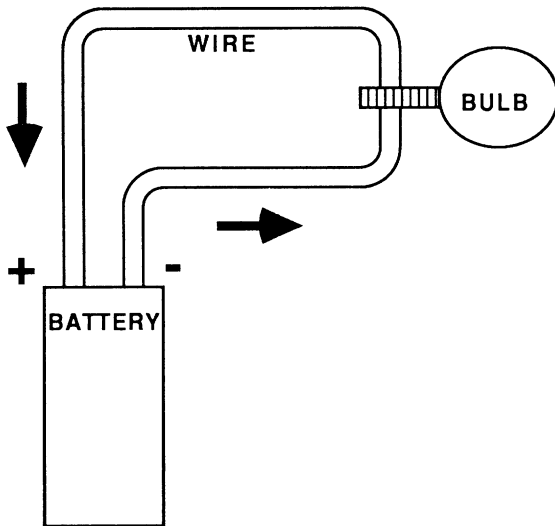

CIRCUIT: A CIRCUIT CONSISTS OF A BATTERY, A WIRE, AND A BULB.

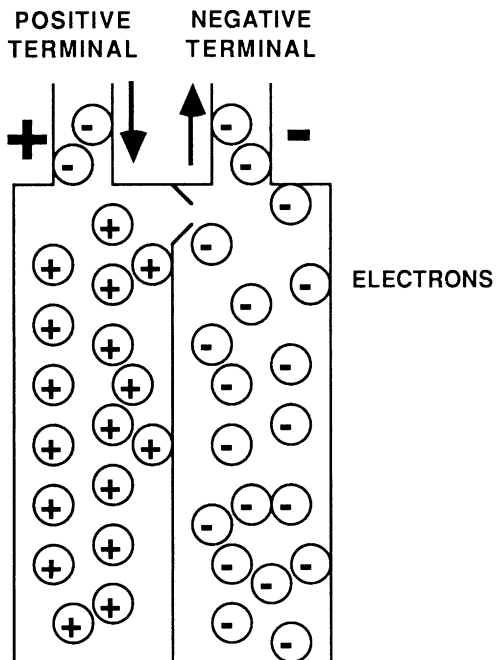

BATTERY (POTENTIAL DIFFERENCE): A BATTERY SEPARATES NEGATIVES (ELECTRONS) FROM POSITIVES.

FIGURE 5. *Model for understanding Ohm's law*

Volume tells us how much space an object takes up. Finding the volume of an object is like finding how many individual cubes there are in a specific object. In the case below, volume is $3 \times 4 \times 2 = 24$ cubes.

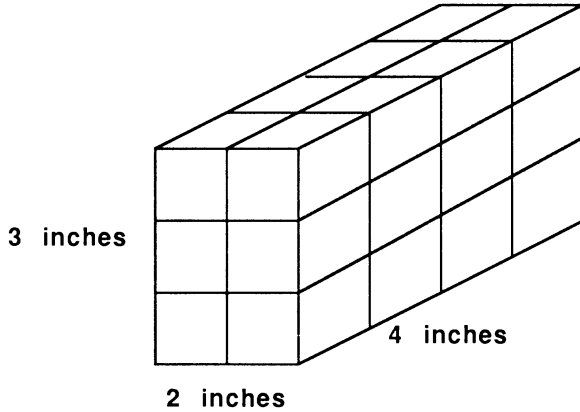

We could theoretically even take one cube out.

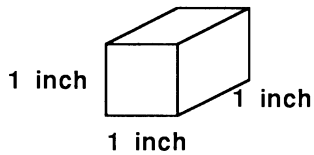

Mass is the number of particles within an object. Obviously, some substances may have more particles in them than others. For example:

BOX A
Mass = 3 particles

BOX B
Mass = 6 particles

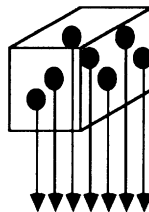
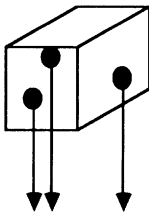

BOX B has two times as many particles and thus twice the gravitational pull.

FIGURE 6. Model for understanding density

verbatim retention, and solved 45% more of the transfer problems than the control students.

Data base system programming. In a series of three studies, students read a 10-page manual for using a data base management system (Mayer, 1980, Experiments 1, 4, & 5). Some students were introduced to a concrete model of the computer system prior to reading the manual (model group), whereas other students were not (control group). As shown in Figure 7, the model of the computer included a file cabinet to represent long-term storage of records; an in basket, a save basket, and a discard basket to represent the sorting function of the system; an erasable scoreboard with labeled spaces to represent data tabulation; and a note pad to represent the output function. Students given the model produced 92% and 129% more correct answers to tests of problem-solving transfer in a series of two experiments (Experiments 1 & 4, respectively); finally, model students recalled 26% more of the conceptual information than control students (Experiment 5).

BASIC computer programming. In a series of studies, students read a 10-page manual describing a simplified BASIC programming language (Mayer, 1976; Mayer & Bromage, 1980). Some students were introduced to a concrete model of the computer system prior to reading the manual (model group) whereas others were not (control group). Figure 8 shows a typical version of the model used in these studies; the model includes a memory scoreboard to help represent the memory function of the computer, an input window with in and out boxes to represent the data entry function, a program list with pointer arrow to represent the control

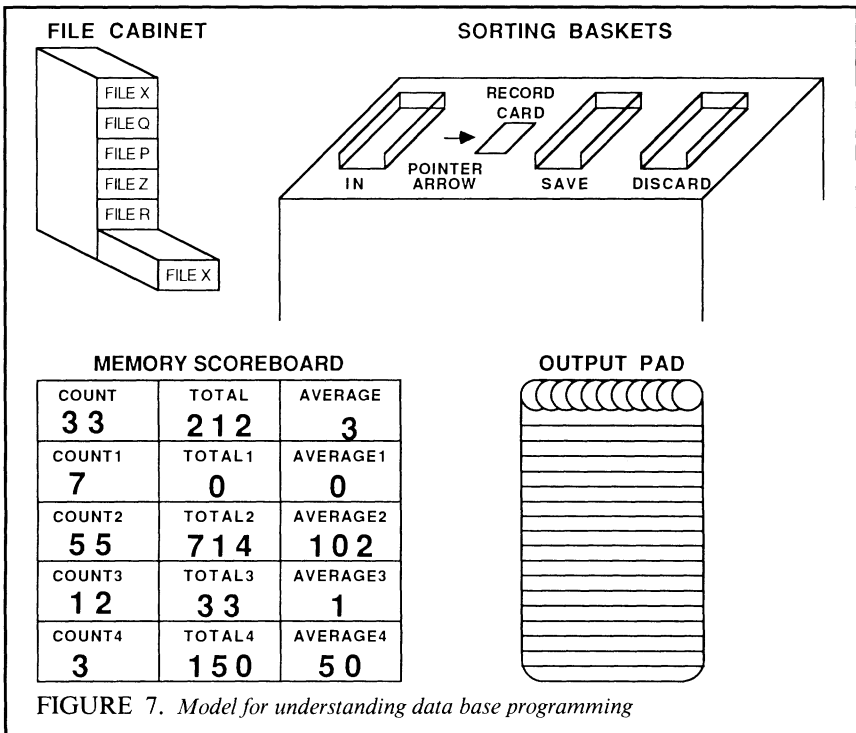
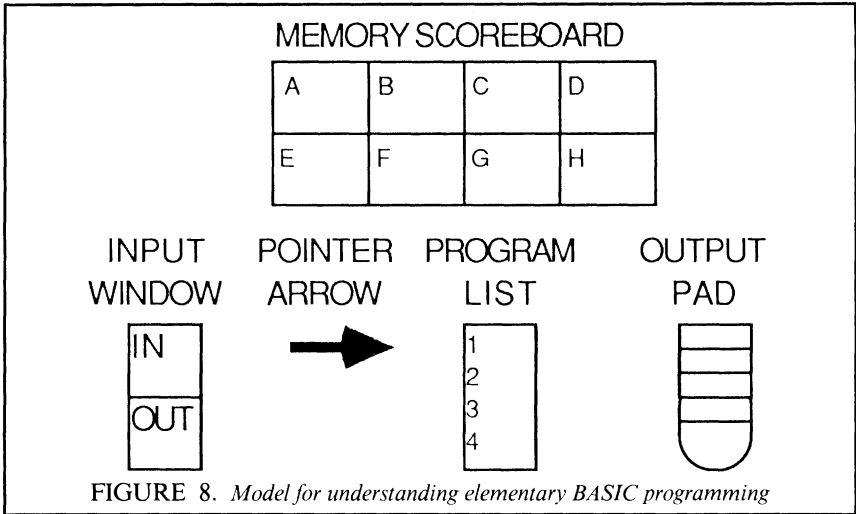

FIGURE 7. Model for understanding data base programming



function, and an output pad to represent the output function. The model students recalled 43%, 44%, and 30% more conceptual information than the control students across three studies that evaluated recall (Mayer & Bromage, 1980, Experiment 1, Experiment 2—Immediate Test, and Experiment 2—Delayed Test), and correctly solved 245%, 100%, and 132% more transfer problems than the control students across three studies that evaluated problem solving (Mayer, 1976, Experiment 1, Experiment 2—Experimenter Control, and Experiment 2—Subject Control).

Model Within the Lesson

This section reviews studies in which a conceptual model was embedded within a lesson, including the reorganization of the lesson to fit within the context of the model.

Nitrogen cycle. Mayer, Dyck, and Cook (1984, Experiment 2) asked students to read a 670-word passage on the nitrogen cycle adapted from a high school biology book (Slesnick, Balzer, McCormack, Newton & Rasmussen, 1980) or a conceptual model version that emphasized the major steps in the nitrogen cycle. The model version contained the model shown in Figure 9 and was organized around the five steps: fixation, in which bacteria catch and convert atmospheric nitrogen (N_2) into ammonia (NH_3); nitrification, in which bacteria in the soil convert ammonia (NH_3) into nitrate (NO_3); assimilation, in which cells in plants take in nitrates (NO_3) and convert them into protein (NH_2); ammonification, in which bacteria in the soil convert protein (NH_3) from decaying plants and wastes into ammonia (NH_3); and denitrification, in which bacteria in the soil convert nitrates (NO_3) in the soil back into atmospheric nitrogen (N_2). The model students remembered 73% more of the conceptual information common to both passages, scored 14% less on verbatim retention, and correctly solved 42% more transfer problems than the control students.

Camera. Bromage & Mayer (1981, Experiment 2) asked students to read an 800-word passage about how to use a 35mm camera (control group) or an enlarged

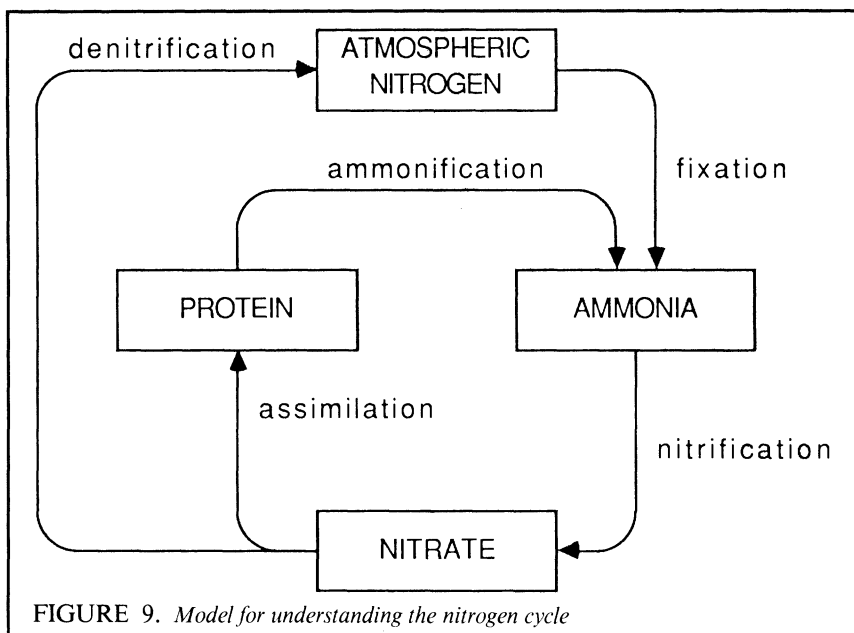

version of the passage that included models of the internal workings of the camera (model group). As summarized in Figure 10, the models described how fuzzy picture subjects and backgrounds are related to rays of light in the camera and how overexposed or underexposed or blurred pictures are related to the amount and timing of light entering the camera and the particle density of the film. The results indicated that the model students exhibited systematic thinking by producing 29% more creative problem-solving answers than the control students.

Brakes. In a recent set of studies carried out in our laboratory (Mayer, in press, Experiment 1 & Experiment 2), students read a 1200-word passage on how brakes work, adapted from the *World Book Encyclopedia* (1986). Some students read passages that included four labeled diagrams, as summarized in Figure 11, whereas others read passages without diagrams. The diagrams showed the major parts of the brakes—such as cylinders, pistons, tubes, drums, and shoes for hydraulic brakes—and showed the major chain of events when the brake pedal is activated—such as the piston moving forward in the master cylinder, brake fluid moving through the tube to the wheel cylinder, the wheel moving forward, the brake shoe pressing into the brake drum, and the wheel slowing down. The words used in the diagrams were identical to those used in the text. In the two studies, respectively, the model students recalled 46% and 23% more of the conceptual information, scored 5% and 8% lower on verbatim retention, and produced 61% and 65% more creative solutions to transfer problems as compared to the control students.

BASIC computer programming. Complementing the foregoing studies on computer programming, another series was conducted in which students read BASIC programming manuals that either contained and referred to a concrete model (model group) or did not (control group). Figure 12 summarizes the model used

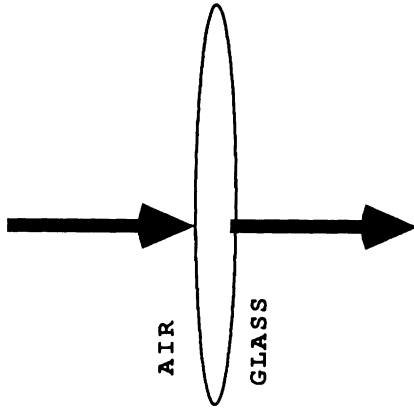

Light waves passing into glass along normal.

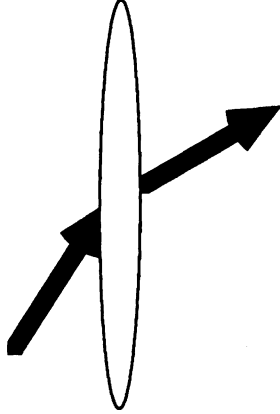

Light waves passing into glass at angle.

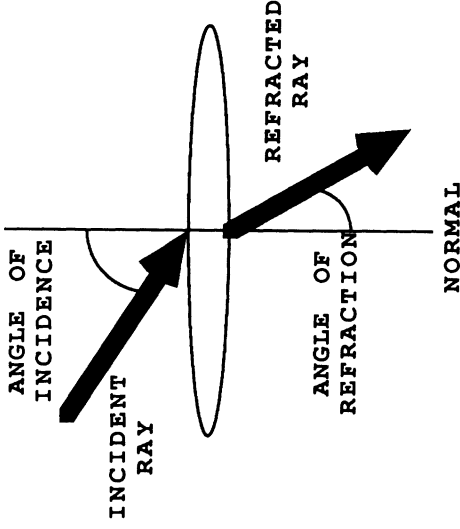

Directions of incident and refracted light.

FIGURE 10. Model for understanding how cameras work

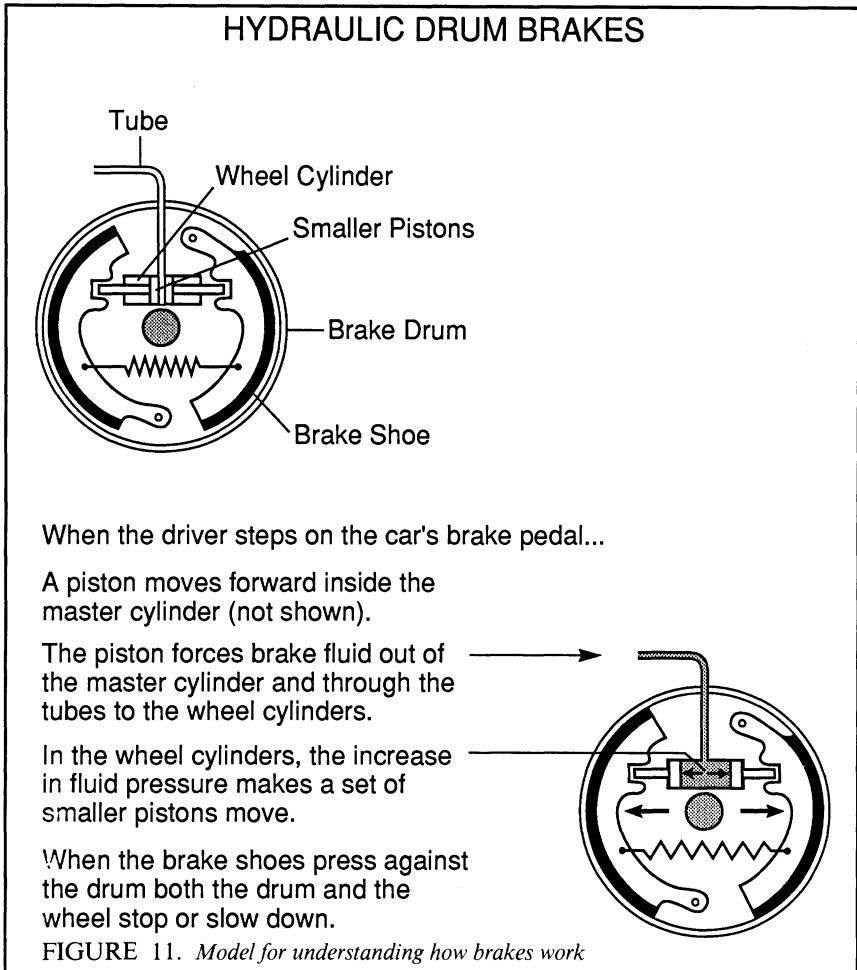

by Bayman & Mayer (1988), which contained a memory scoreboard, input queue with pointer, output screen, program list with pointer, scratch pad work space, and run-wait light. Across five separate studies that evaluated problem-solving transfer performance (Mayer 1975, Experiment 1—No Flow Chart, Experiment 1—Flow Chart, and Experiment 2; Mayer, 1976, Experiment 1; and Bayman & Mayer, 1988, Experiment 1), the model group outperformed the control group by 64%, 460%, 52%, 33%, and 21%.

Conclusion

Can Conceptual Models Improve Students' Systematic Thinking?

We began with the hypothesis that providing concrete models would help novices learn to think systematically about to-be-learned scientific information. If providing conceptual models helps to foster systematic thinking, we can predict a pattern in

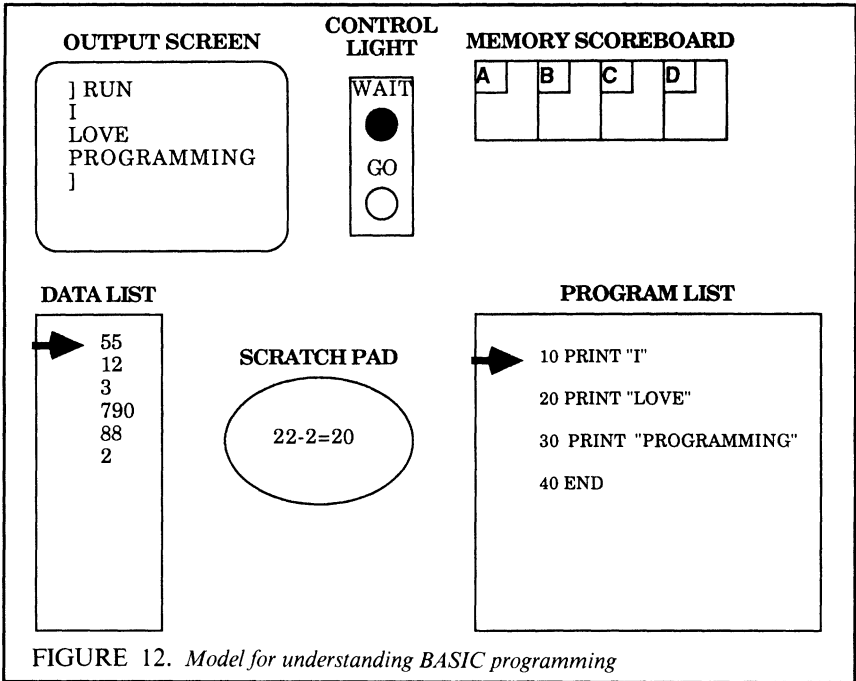

which students who learn with concrete models recall more conceptual information, perform more poorly on verbatim retention of information, and most important, generate more creative solutions on transfer problems, as compared to students who learn without models. Table 3 summarizes how well these three predictions were supported by the research results.

Prediction 1: Models will improve conceptual retention. The first prediction is that conceptual recall will be higher for the model group than the control group. The rationale for this prediction is that the model helps students direct their attention toward the conceptual objects, locations, and actions described in the lesson. As summarized in Table 3, there were 10 separate tests in which the conceptual recall of a model group was compared to the conceptual recall of a control group. In all 10 tests, the model group outperformed the control group with a median improvement of 57%.

TABLE 3
Evaluation of three predictions

Type of test	Number of tests	Percentage consistent with predictions	Median percentage increase or decrease
Conceptual recall	10	100%	+57%
Verbatim retention	5	100%	-14%
Problem solving transfer	16	100%	+64%

Prediction 2: Models will reduce verbatim retention. The second prediction is that verbatim retention will be lower for the model group than the control group. The rationale for this prediction is that the model helps students reorganize the material to fit in with their conceptual model and when students actively reorganize the material they tend to lose the original presentation format. In five separate comparisons of the verbatim retention by model and control students, the control students outperformed the model students in all five tests. The median reduction in performance for the model students was 14%, as summarized in Table 3.

Prediction 3: Models will improve problem-solving transfer. The most crucial prediction is that models will improve the ability of students to transfer what they have learned to creatively solving new problems. The ability to generate novel solutions to new problems is the hallmark of systematic thinking; if students have built models that they can mentally manipulate, they will be better able to solve transfer problems. As summarized in Table 3, this review yielded 16 separate comparisons between model and control students on problem-solving transfer; in each of these comparisons, the model group outperformed the control group, with a median improvement of 64%.

These results provide consistent support for the idea that conceptual models for scientific text can lead to changes in the way that students think about the material. It should be noted that this review has focused on dependent measures—conceptual recall, verbatim retention, and problem-solving transfer—that are intended to evaluate differences in systematic thinking. Had we focused on traditional measures such as overall amount recall or overall amount correct on a comprehension test, we would not have found strong differences between model and control groups. What is wrong with overall recall or comprehension performance? These measures are not useful for the present review because they do not provide information concerning how models help students to select, organize, and use scientific information. In contrast, to examine students' understanding requires a focus on the three dependent measures used in this study as well as more fine grained analyses that should be a part of future research.

How Should Conceptual Models Be Used in Instruction?

Although this review provides a consistently affirmative answer to the question of whether models can foster student understanding, it also raises several additional questions concerning the what, when, where, who, and why of using conceptual models in instruction.

Question 1: What is a good model? The first question concerns the characteristics of good models. Of course, this question must be revised in order to describe the purpose of the model; in light of this review we can ask: "What is a good model for improving novices' transfer performance?" The foregoing review suggests, but does not adequately test, several characteristics of good models for transfer that warrant future research study:

Complete. Good models contain all of the essential parts, states, or actions of the system as well as the essential relations among them, so that the learner can be able to see how the system works.

Concise. Good models are presented at a level of detail that is appropriate for the learner. Rather than provide so much detail that the student is overwhelmed, good models summarize and epitomize the system they seek to explain. Rather

than provide a “blood and guts” description of each part, good models describe the general functions of each part. Each of the models described in this review involved a small number of steps or states—generally about five—and only a few parts—generally less than a dozen.

Coherent. Good models make intuitive sense to the learner so that the operation is transparent; the model or analogy used is a logical system that contains parts and rules for how the parts interact.

Concrete. Good models are presented at a level of familiarity that is appropriate for the learner, including physical models or visual models.

Conceptual. Good models are based on material that is potentially meaningful, that is, on material that explains how some system operates.

Correct. Good models correspond at some level to the actual events or objects they represent. The major parts and relationships in the model correspond to the major parts and relationships in the actual object or event.

Considerate. Good models are presented in a manner that is appropriate to the learner, using learner appropriate vocabulary and organization.

In short, models are “good” with respect to certain learners and certain instructional goals. The current review, although consistent with the seven characteristics listed above, does not confirm them. Systematic research is needed to identify the relative contributions of each characteristic and to establish better operational definitions of each.

Question 2: Where should models be used? The second question concerns the conditions under which models should be used. In the foregoing review, models were effective for explanative material, that is, material that explained how some system worked. Correspondingly, visual mnemonic techniques have been shown to be highly effective for helping students to remember rote lists and paired associates (Levin, 1981).

Question 3: When should models be used? The third question concerns the placement of models within a lesson. Several of the studies in the foregoing review provided evidence that models are effective when placed either before or integrated within a lesson but not when placed after a lesson (Mayer, 1976, 1980; Mayer & Bromage, 1980).

Question 4: Who is a model good for? The fourth question asks about individual differences in the effectiveness of models. The results summarized in Table 3 are based on students who had low prior knowledge and low aptitude for the material in the lesson. In studies that also included high-aptitude students, the positive effects of models on systematic thinking were eliminated; for example, high-aptitude model students did not perform better than high-aptitude control students on problem solving (Bayman & Mayer, 1988; Mayer, 1980, Experiment 4) or on recall of conceptual information (Mayer & Bromage, Experiment 1). The high-aptitude students are more likely to come to the lesson with already existing models (or the ability to rapidly construct them); for these students, the simplified, teacher-generated models in the model groups may conflict with their more sophisticated models.

Question 5: Why use models? The final question concerns instructional goals. The models described in the foregoing review were intended to foster student understanding, as manifested in creative problem-solving transfer performance. When the goal of instruction is student understanding of potentially meaningful

explanations, conceptual models can be effective tools. Apparently, conceptual models can provide an assimilative context for students to build useful mental models.

In summary, the results of this review encourage continued development of theory and practice for using models to promote understanding. One particularly exciting avenue concerns the role of interactive computer graphic simulations as a vehicle for expanding the power of conceptual models (White, 1984).

APPENDIX A

Three types of cognitive processing

Guide attention

Definition: Reader transfers certain idea units from the passage to short-term memory.

Example: Reader attends to 20 of the 78 idea units in the radar passage.

Build internal connections

Definition: Reader organizes idea units in short-term memory into coherent structure.

Example: Reader uses 'process' structure, so that idea units are arranged into five steps (see Appendix B).

Build external connections

Definition: Reader integrates new structure with existing knowledge in long-term memory.

Example: Reader relates radar to bouncing ball (see Appendix B).

APPENDIX B

Some internal and external connections for the radar passage

Internal connections

Transmission: First, a radio pulse is sent out from an antenna.

Reflection: Second, the pulse strikes a remote object.

Reception: Third, the reflected pulse returns to the antenna.

Measurement: Fourth, the trip out and back takes a certain amount of time.

Conversion: Fifth, this time corresponds to the distance of the remote object.

External connections

Transmission is like throwing a ball.

Reflection is like the ball hitting a wall.

Reception is like catching the ball after it bounces off the wall.

Measurement is like determining how long it took for the ball to come back.

Conversion is like noticing that the further away you are from the wall the longer it takes for the ball to come back.

Note

¹ A conceptual model can be thought of as a special kind of comparative advance organizer (Ausubel, 1968) or a special kind of text illustration (Lumsdaine, 1963), that is, as an organizer or illustration that shows how the parts and operations of a system fit together.

References

- Alesandrini, R. L. (1984). Pictures and adult learning. *Instructional Science*, 13, 63–77.
- Anglin, G. J., & Stevens, J. T. (1986). Prose-relevant pictures and recall from science text. *Perceptual and Motor Skills*, 63, 1143–1148.

- Ausubel, D. P. (1968). *Educational psychology: A cognitive view*. New York: Holt, Rinehart and Winston.
- Bayman, P., & Mayer, R. E. (1988). Using conceptual models to teach BASIC computer programming. *Journal of Educational Psychology, 80*, 291–298.
- Bromage, B. K., & Mayer, R. E. (1981). Relationship between what is remembered and creative problem-solving performance in science learning. *Journal of Educational Psychology, 73*, 451–461.
- Clarke, D. (1977). *The encyclopedia of how it works*. New York: A & W Publishers.
- Cormier, S. M., & Hagman, J. D. (Eds.). (1987). *Transfer of learning: Contemporary research and applications*. San Diego: Academic Press.
- Curtis, R. V. (1988). When is a science analogy like a social studies analogy? A comparison of text analogies across two disciplines. *Instructional Science, 13*, 169–177.
- Curtis, R. V., & Reigeluth, C. M. (1984). The use of analogies in written text. *Instructional Science, 13*, 99–117.
- Dean, R. S., & Enomoto, P. A. (1983). Pictorial organization in prose learning. *Contemporary Educational Psychology, 8*, 20–27.
- deKleer, J., & Brown, J. S. (1981). Mental models of physical mechanisms and their acquisition. In J. R. Anderson (Ed.), *Cognitive skills and their acquisition* (pp. 258–310). Hillsdale, NJ: Erlbaum.
- deKleer, J., & Brown, J. S. (1983). Assumptions and ambiguities in mechanistic mental models. In D. Gentner & A. L. Stevens (Eds.), *Mental models* (pp. 155–190). Hillsdale, NJ: Erlbaum.
- Gentner, D. (1983). Structure mapping: A theoretical framework for analogy. *Cognitive Science, 7*, 155–170.
- Gentner, D., & Gentner, D. R. (1983). Flowing waters or teeming crowds: Mental models of electricity. In D. Gentner & A. L. Stevens (Eds.), *Mental models* (pp. 99–129). Hillsdale, NJ: Erlbaum.
- Gentner, D., & Stevens, A. L. (Eds.). (1983). *Mental models*. Hillsdale, NJ: Erlbaum.
- Hayes, D. A., & Henk, W. A. (1986). Understanding and remembering complex prose augmented by analogic and pictorial illustration. *Journal of Reading Behavior, 18*, 63–78.
- Herron, W. B., Palmer, N. P., & Joslin, P. H. (1972). *Matter, life, and energy*. Chicago: Rand McNally.
- Holmes, B. C. (1987). Children's inferences with print and pictures. *Journal of Educational Psychology, 79*, 14–18.
- Levie, W. H., & Lentz, R. (1982). Effects of text illustrations: A review of research. *Educational Communication and Technology, 30*, 195–232.
- Levin, J. R. (1981). The mnemonic '80s: Keywords in the classroom. *Educational Psychologist, 16*, 65–82.
- Levin, J. R., & Berry, J. K. (1980). Children's learning of all the news that's fit to picture. *Educational Communication and Technology, 28*, 177–185.
- Levin, J. R., & Lesgold, A. M. (1978). On pictures in prose. *Educational Communication and Technology, 26*, 233–243.
- Luchins, A. S., & Luchins, E. H. (1970). *Wertheimer's seminars revisited: Problem solving and thinking* (Vol. 1). Albany, NY: SUNY Press.
- Lumsdaine, A. (1963). Instruments and media of instruction. In N. L. Gage (Ed.), *Handbook of research on teaching*. Chicago: Rand McNally.
- Mayer, R. E. (1975). Different problem-solving competencies established in learning computer programming with and without meaningful models. *Journal of Educational Psychology, 67*, 725–734.
- Mayer, R. E. (1976). Some conditions of meaningful learning for computer programming: Advance organizers and subject control of frame order. *Journal of Educational Psychology, 68*, 143–150.

- Mayer, R. E. (1980). Elaboration techniques that increase the meaningfulness of technical text: An experimental test of the learning strategy hypothesis. *Journal of Educational Psychology, 72*, 770–784.
- Mayer, R. E. (1983). Can you repeat that? Qualitative effects of repetition and advance organizers on learning from science prose. *Journal of Educational Psychology, 75*, 40–49.
- Mayer, R. E. (1984). Aids to text comprehension. *Educational Psychologist, 19*, 30–42.
- Mayer, R. E. (1985). Structural analysis of science prose: Can we increase problem-solving performance? In J. Black & B. Britton (Eds.), *Understanding expository phase* (pp. 65–87). Hillsdale, NJ: Erlbaum.
- Mayer, R. E. (1987a). *Educational psychology: A cognitive approach*. Boston: Little, Brown.
- Mayer, R. E. (1987b). Instructional variables that influence cognitive processing during reading. In B. K. Britton & S. Glynn (Eds.), *Executive control progresses in reading* (pp. 201–216). Hillsdale, NJ: Erlbaum.
- Mayer, R. E. (in press). Systematic thinking fostered by illustrations in scientific text. *Journal of Educational Psychology*.
- Mayer, R. E., & Bromage, B. K. (1980). Different recall protocols for technical texts due to advance organizers. *Journal of Educational Psychology, 72*, 209–225.
- Mayer, R. E., & Cook, L. B. (1980). Effects of shadowing on prose comprehension and problem solving. *Memory & Cognition, 8*, 101–109.
- Mayer, R. E., Dyck, J. L., & Cook, L. K. (1984). Techniques that help readers build mental models from scientific text: Definitions pretraining and signaling. *Journal of Educational Psychology, 76*, 1089–1105.
- Michalski, R. S., Carbonell, J. G., & Mitchell, T. M. (Eds.). (1986). *Machine learning: An artificial intelligence approach* (Vol. 2). Los Altos, CA: Morgan Kaufmann.
- Readence, J. E., & Moore, D. W. (1981). A meta-analysis of the effect of adjunct pictures on reading comprehension. *Psychology in the Schools, 18*, 218–224.
- Reid, D. J., & Beveridge, M. (1986). Effects of text illustrations on children's learning of a school science topic. *British Journal of Educational Psychology, 56*, 294–303.
- Reid, D. J., Briggs, N., & Beveridge, M. (1983). The effect of picture upon the readability of a school science topic. *British Journal of Educational Psychology, 53*, 327–335.
- Royer, J. M., & Cable, G. W. (1976). Illustrations, analogies, and facilitative transfer in prose learning. *Journal of Educational Psychology, 68*, 205–209.
- Rusted, J. (1984). Differential facilitation by pictures of children's retention of written texts: A review. *Current Psychology Research and Review, 3*, 61–71.
- Rusted, J., & Coltheart, M. (1979a). Facilitation of children's prose recall by the presence of pictures. *Memory and Cognition, 7*, 354–359.
- Rusted, J., & Coltheart, V. (1979b). The effect of pictures on the retention of novel words and prose passages. *Journal of Experimental Child Psychology, 28*, 516–524.
- Rusted, J., & Hodgson, S. (1985). Evaluating the picture facilitation effect in children's recall of written texts. *British Journal of Educational Psychology, 55*, 288–294.
- Saroyan, A., & Geis, G. L. (1988). An analysis of guidelines for expert reviewers. *Instructional Science, 17*, 101–128.
- Schallert, D. L. (1980). The role of illustrations in reading comprehension. In R. Spiro, B. Bruce, & W. Brewer (Eds.), *Theoretical issues in reading comprehension* (pp. 503–524). Hillsdale, NJ: Erlbaum.
- Slesnick, I. L., Balzar, L., McCormack, A. J., Newton, D. E., & Rasmussen, F. A. (1980). *Biology*. Glenview, IL: Scott, Foresman.
- Simon, H. A. (1969). *The sciences of the artificial*. Cambridge, MA: MIT Press.
- West, L. H. T., & Pines, A. L. (Eds.). (1985). *Cognitive structure and conceptual change*. Orlando, FL: Academic Press.
- White, B. Y. (1984). Designing computer games to help physics students understand Newton's law of motion. *Cognition and Instruction, 1*, 69–108.

Richard E. Mayer

White, R. T., & Mayer, R. E. (1980). Understanding intellectual skills. *Instructional Science*, 9, 101–127.

World Book Encyclopedia. (1986). Chicago: World Book Encyclopedia.

Author

RICHARD E. MAYER, Professor and Chair of Psychology, University of California, Santa Barbara, CA 93106. *Specializations*: human learning and problem solving, prose processing.