

MEMORANDUM  
RM-6014-RC  
MAY 1969

## MODELS OF SEGREGATION

Thomas C. Schelling

Copyright © 1969  
THE RAND CORPORATION

This study is presented as a competent treatment of the subject, worthy of publication. The Rand Corporation vouches for the quality of the research, without necessarily endorsing the opinions and conclusions of the authors.

Published by The RAND Corporation

MEMORANDUM

RM-6014-RC

MAY 1969

MODELS OF SEGREGATION

Thomas C. Schelling



PREFACE

If anything characterizes economics, it is explicit analysis of the relation of individual decisions to aggregate phenomena. This method is much less common among sociologists and others who deal with the ecology of colors, religions or language groups. I discovered this in attempting to locate reading material for a class at Harvard. I found a great deal of attention to the motives and origins of individual behavior and to many collective phenomena that result from the interaction of individuals, but little explicit theory relating what goes on in the aggregate to what determines the behavior of the individuals who comprise the aggregate.

So I have attempted some theory myself. Part of the process is identifying the characteristics of people, perceptions, activities, boundaries, communications, etc., by which to define the individual behaviors and the collective results. The other part is the search for suggestive models and experiment with the models to see whether they produce any new understanding or show how certain processes work themselves out.

The work is not finished, but enough has been done to illustrate the technique and to permit some judgment on its use. Some models and results are therefore being communicated in this memorandum.

I anticipate a question that has been voiced at oral presentations. Why, especially if I am an economist, do I leave prices and incomes out? Do not the models need prices or incomes to simulate reality?

My answer is in three parts. First, I have not got that far. Second, if the models are useful at all they are probably useful without prices and incomes, even if

they would be more useful with prices and incomes. Third, these models are so abstract that nothing will make them look like reality, and their comparative advantage is in the direction of simplicity rather than detail. If we are to go to the trouble to put prices and incomes in the models, I am not sure that these are the models to put them in. But we shall see; this is just stage one.

The simulation model of Chapter II has at this date been a manual, table-top exercise. John Casti has been preparing a versatile computer program that will shortly give me freedom to explore a wider variety of hypotheses and that will generate more adequate samples for analysis. That will be another publication at a later date.

I much appreciate RAND's sponsorship of this work and hope that, like so much of RAND's research, it will prove to be "basic" enough to be applied somewhere.

SUMMARY

Some segregation results from the practices of organizations; some is deliberately organized; some results from specialized communication systems, like different languages; some results from correlation with another variable that is non-random. And some segregation results from the interplay of individual choices that discriminate.

This memorandum is about the segregation that can result from discriminatory individual behavior--behavior affected by an awareness, conscious or unconscious, of sex or age or religion or color or whatever the basis of segregation is, an awareness that influences decisions on where to live, whom to sit by, or what occupation to join or to avoid. It examines some of the individual incentives, and perceptions of difference, that can lead collectively to segregation. It also examines the extent to which inferences can be drawn, from the phenomenon of collective segregation, about the preferences of individuals, the strengths of those preferences, and the facilities for exercising them.

It omits two main processes of segregation that operate in the United States. One is organized action. The other is the process, largely but not entirely economic, by which the poor get separated from the rich, the less educated from the more educated, the poorly dressed from the well dressed, in where they work and live, whom they know, and whom they go to school with.

The paper provides two models, both concerned with quantitative dynamics. The first, presented in Chapter II, is a simulation model in which individuals distribute themselves along a line or within an area in accordance with preferences about the composition of their neighborhoods. In this model everybody defines his neighborhood by refer-

ence to his own location; there are no geographical boundaries. An individual moves if he is not content with the color mixture of his neighborhood, moving if he can to where the color mixture meets his demands. Starting from an initial random distribution, individuals are moved until equilibrium is reached. The ratio of the two colors in the population, the demands for neighbors like oneself, and the size of the neighborhood within which an individual's preferences operate, are varied in this model.

The second model is an analytic one. Space is compartmented. People are either in or out of a common neighborhood and care about the color ratio within the neighborhood. Preferences of individuals can vary, some being more tolerant than others. In this model we examine the questions, what distribution of color tolerances among the population may be compatible with dynamically stable mixtures, what effect the initial conditions and the dynamics of movement will have on the outcome, and what kinds of numerical constraints may alter the results.

A final chapter applies some of the analytics of the second model to an exploration of "neighborhood tipping," a phenomenon that is alleged to occur sometimes when a recognizable new minority enters a neighborhood. The "neighborhood" in this analysis is the compartmented space of the second model, with a ceiling on the total population that the neighborhood can contain. Several configurations of numbers and tolerances are examined, and some variety of outcomes is obtained.

The analysis is abstract. Any two-fold distinction could constitute an interpretation--blacks and whites, boys and girls, officers and enlisted men. The only requirement of either model is that the distinction be two-fold, recognizable, and exhaustive. Except slightly in the chapter on "tipping," the paper is purely formal and makes no use of empirical data.



CONTENTS

PREFACE .....	iii
SUMMARY .....	v
Chapter	
I. INTRODUCTION .....	1
II. SPATIAL SEGREGATION: A PROXIMITY MODEL .....	12
III. A BOUNDED-NEIGHBORHOOD MODEL .....	48
IV. NEIGHBORHOOD TIPPING .....	73



## I. INTRODUCTION

People get separated along many different lines and in many different ways. There is segregation by sex, age, income, language, religion, color, taste, comparative advantage and the accidents of historical location. Some segregation results from the practices of organizations; some segregation is deliberately organized; and some results from the interplay of individual choices that discriminate. Some of it results from specialized communication systems, language differences being a conspicuous example. Some segregation is a byproduct of other modes of segregation: residence will tend to be correlated with job location and transport.

If blacks exclude whites from their church, or whites exclude blacks, the segregation is organized, and it may be reciprocal or one-sided. If blacks just happen to be Baptists and whites Methodists, the two colors will be segregated Sunday morning, whether they intend to be or not. If blacks tend to join a black church because they are more comfortable among their own color, and whites a white church for the same reason, undirected individual choice can lead to segregation. And if the church bulletin board is where people advertise rooms for rent, blacks will rent rooms from blacks and whites from whites because of a communication system that is correlated with churches that are correlated with color.

Some of the same mechanisms segregate college professors. The college may own some housing, from which all but college staff are excluded. Professors choose housing commensurate with their incomes, and houses are clustered by price while professors are clustered by income. Some professors prefer an academic neighborhood; any differential in professorial density will cause them to converge and increase the local density. And house-hunting profes-

sors learn about available housing from other professors and their wives, and the houses they learn about are the ones in neighborhoods where professors already live.

The similarity ends there, and nobody is about to propose a commission to desegregate academics. Professors are not much missed by those they escape from in their residential choices. They are not much noticed by those they live among, and, though proportionately concentrated, they are usually a minority in their neighborhood. While indeed they escape numerous classes of people that they would not care to live among, they are more conscious of where they do live than of where they don't live, and the active choice is more like congregation than segregation, though the result may not be so different.

This paper is about the kinds of segregation--or separation, or sorting--that can result from discriminatory individual behavior. By "discriminatory" I mean reflecting an awareness, conscious or unconscious, of sex or age or religion or color or whatever the basis of segregation is, an awareness that influences decisions on where to live, whom to sit by, what occupation to join or avoid, whom to play with or talk to. The paper examines some of the individual incentives, and perceptions of difference, that can lead collectively to segregation. The paper also examines the extent to which inferences can be drawn, from the phenomenon of collective segregation, about the preferences of individuals, the strengths of those preferences, and the facilities for exercising them.

The ultimate concern of the paper is segregation by "color" in the United States. The analysis, though, is so abstract that any two-fold distinction could constitute an interpretation--whites and blacks, boys and girls, officers and enlisted men, students and faculty, teenagers and grownups. The only requirement of the model is that the distinction be two-fold, exhaustive, and recognizable.

This paper omits at least two main processes of segregation that operate in the United States. One is organized action, legal or illegal, coercive or merely exclusionary, subtle or flagrant, open or covert, kindly or malicious, moralistic or pragmatic. The other is the process, largely but not entirely economic, by which the poor tend to get separated from the rich, the less educated from the more educated, the unskilled from the skilled, the poorly dressed from the well dressed, in where they work, live, eat, and play, whom they know and whom they date and whom they go to school with. Evidently color in the United States is correlated with income, and income with residence, so that even if residential choices were color-blind and unconstrained by organized discrimination, whites and blacks would not be randomly distributed among residential areas.\*

This is not to claim that either the organized discrimination or the economically induced segregation is less powerful, or less important, or less a matter of social concern, than the segregation that results from individual action. Indeed, aside from the question of which mechanism may account for the greater part of observed separation by color, the organized segregation involves civil rights, and the economically determined segregation raises questions of social equity, and on those grounds alone the subject of this paper might well be put in third place. Still, in a matter as important as racial segregation in the United States, third place is high enough to deserve systematic attention.

It is not easy, though, to draw the lines between "individually motivated" segregation, the more organized

---

\*A comprehensive treatment of socio-economic differentials between whites and non-whites, in relation to residential patterns, is in A. H. Pascal, The Economics of Housing Segregation, RM-5510-RC, The RAND Corporation, Santa Monica, California, November 1967.

kind, and the economically induced kind. Habit and tradition are substitutes for organization. Fear of sanctions can coerce behavior whether or not the fear is justified and whether the feared sanctions are consensual, conspiratorial or dictated. Common expectations can lead to concerted behavior, somewhat as organization can. ("Guilt by association," when sanctioned by ostracism, is an example of a social rule that is often self-enforcing.)

The economically induced separation is also intermixed with discrimination. To choose a neighborhood is to choose neighbors. To pick a neighborhood with especially good schools is to pick a neighborhood of people who appreciate schools (or of people who want to be with the kind of people who appreciate schools). People may furthermore rely, even in making economic choices, on information that is itself color-discriminating; believing that darker-skinned people are on the average poorer than lighter-skinned, one may consciously or unconsciously rely on color as an index of poverty (or, believing that others rely on color as an index, adopt their signals and indices in order to coincide with them). And if the process goes far enough, alienation, strangeness, fear, hostility, and sheer habit can accentuate the tendency toward avoidance. If the sentiment is reciprocated, positive feedback will amplify the segregating tendencies of both groups.

So it is futile to impute percentage shares of responsibility to the several different mechanisms that underlie racial segregation in the United States. Economic segregation might statistically explain some initial degree of segregation; if that degree were enough to cause color-consciousness, a superstructure of pure discrimination could complete the job; while the economic segregation could therefore, in a sense, be considered "fully responsible," eliminating altogether the economic differentials might not then cause the collapse of the segregated system that it had generated.

For all these reasons the lines between individually motivated, collectively enforced, and economically induced segregation are not clear lines at all. These are furthermore not the only mechanisms of segregation, though they are three useful headings.\* It may turn out that the disappearance of segregation requires the disappearance of all three, and the question of relative potency is meaningless. Still, they are very different mechanisms and each has to be separately understood.

This paper, then, is about those mechanisms that translate unorganized individual behavior into collective results.

#### INDIVIDUAL INCENTIVES AND COLLECTIVE RESULTS

Economists are familiar with systems that lead to aggregate results that the individual neither intends nor needs to be aware of, results that sometimes have no recognizable counterpart at the level of the individual. The creation of money by a commercial banking system is one; the way savings decisions cause depressions or inflations is another.

Similarly, biological evolution is responsible for a lot of sorting and separating, but the little creatures that mate and reproduce and forage for food would be amazed to know that they were bringing about separation of species, territorial sorting of species, or the extinction of species. Among social examples, the coexistence or extinction of second languages is a phenomenon that, though affected by decrees and school curricula, is a massive "free market" activity with results that correspond to no conscious collective choice.

---

\*Separate or specialized communication systems--especially distinct languages--can have a strong segregating influence that, though interacting with the three processes mentioned, are nevertheless a different mechanism.

Romance and marriage are exceedingly individual and private activities, at least in this country, but their genetic consequences are altogether aggregate. The law and the church may constrain us in our choices, and some traditions of segregation are enormously coercive; but outside of royal families there are few marriages that are part of a genetic plan. When a short boy marries a tall girl, or a blonde a brunette, it is no part of the individual's purpose to increase genetic randomization or to change some frequency distribution within the population.

In some cases small incentives, almost imperceptible differentials, can lead to strikingly polarized results. Gresham's Law is a good example. Some traditions, furthermore, are sternly self-enforcing; passing to the right of an oncoming car. Some collective actions have almost the appearance of being organized--fads in clothing, dancing and car styles.

Some of the phenomena of segregation may be similarly complex in relation to the dynamics of individual choice. One might even be tempted to suppose that some "unseen hand" separates people in a manner that, though foreseen and intended by no one, corresponds to some consensus or collective preference or popular will. But in economics we know a great many macro-phenomena, like depression and inflation, that do not reflect any universal desire for lower incomes or higher prices. Similarly with bank failures and market crashes. What goes on in the "hearts and minds" of small savers has little to do with whether or not they cause a depression; the hearts and minds and motives and habits of millions of people who participate in a "segregated society" may or may not bear close correspondence with the massive results that collectively they can generate.



We also know that people who would not support the government with private donations may vote a system of mandatory taxes to finance public goods. The worth of a new turnpike may depend on keeping traffic below the level of congestion that would just equalize its attractiveness with that of alternative routes. "Freedom of choice" is sometimes nothing more than the lack of enforceable contract.

Evolutionary processes may lead to typewriter keyboards, weights and measures and the pitches of screws, systems of coinage, and lefthand or righthand automobile drive, that are self-perpetuating in spite of inefficiency until a heroic effort can bring about concerted change. Yet, also, some massive concerted changes can occasionally be brought about by some simple manipulation, as when daylight saving goes into effect or when a round table replaces a rectangular one in a highly stratified conference room.

A special reason for doubting any social efficiency in aggregate segregation is that the range of choice is so meager. The demographic map of almost any American metropolitan area suggests that it is easy to find residential areas that are all-white or nearly so and areas that are all-black or nearly so but hard to find localities in which neither whites nor non-whites are more than, say, three-quarters of the total. And, comparing decennial maps, it is nearly impossible to find an area that, if integrated within that range, will remain integrated long enough for a man to get his house paid for or his children through school. The distribution is so U-shaped that it is virtually a choice of two extremes.

#### SOME QUANTITATIVE CONSTRAINTS

Counting blacks and whites in a residential block or on a baseball team will not tell how they get along. But

it tells something, especially if numbers and ratios matter to the people who are moving in or out of the block or being recruited for the team. And with quantitative analysis there are usually a few logical constraints, somewhat analogous to the balance-sheet identities in economics. Being logical constraints, they contain no news unless one just never thought of them before.

The simplest constraint on dichotomous mixing is that, within a given set of boundaries, not both groups (colors, sexes) can enjoy numerical superiority. Within the population as a whole, the numerical ratio is determined at any given time; but locally, in a city or a neighborhood, a church or a school, either blacks or whites can be a majority. But if each insists on being a local majority, there is only one mixture that will do it --complete segregation.

Relaxing the condition, if whites want to be at least three-fourths and blacks at least one-third, it won't work. If whites want to be at least two-thirds and blacks no fewer than one-fifth, there is a small range of mixtures that meet the conditions; and not everybody can be in the mixtures if the aggregate ratio is outside the range.

Other constraints have to do with small numbers. A classroom can be mixed but the teacher is one color; mixed marriages can occur only in the ratio of one to one; a three-man team cannot represent both colors equally, and even in a two-man team each member has company exclusively of one color.

In spatial arrangements, like a neighborhood or a hospital ward, everybody is next to somebody. A neighborhood may be 10 percent black or white; but if you have a neighbor on either side, the minimum non-zero percentage of opposite color is 50. If people draw their boundaries

differently we can have everybody in a minority: at dinner, with men and women seated alternately, everyone is outnumbered two to one locally by the opposite sex but can join a three-fifths majority if he extends his horizon to the next person on either side. If blacks occupy a sixth of the beds in a hospital and there are four beds to a room, at least 40 percent of the whites will be in all-white rooms.

Transitions involve the usual relations among numbers and their derivatives. A college that wants suddenly to have 10 percent of its students black will have to admit 40 percent black freshmen, only to discover that it must then pass three classes before accepting more. Professions, occupations and residences are constrained by these numerical relations, whether it is color, sex, nationality, age or degree status that is involved.

#### SEPARATING MECHANISMS

The simple mathematics of ratios and mixtures tells us something about what outcomes are logically possible, but tells us little about the behavior that leads to, or that leads away from, particular outcomes. To understand what kinds of segregation or integration may result from individual choice, we have to look at the processes by which various mixtures and separations are brought about. We have to look at the incentives and the behavior that the incentives motivate, and particularly the way that different individuals comprising the society impinge on each other's choices and react to each other's presence.

There are many different incentives or criteria by which blacks and whites, or boys and girls, become separated. Whites may simply prefer to be among whites and blacks among blacks. Alternatively, whites may merely avoid or escape blacks and blacks avoid or escape whites. Whites may prefer the company of whites, while the blacks

don't care. Whites may prefer to be among whites and blacks also prefer to be among whites, but if the whites can afford to live or to eat or belong where the blacks cannot afford to follow, separation can occur.

Whites and blacks may not mind each other's presence, may even prefer integration, but may nevertheless wish to avoid minority status. Except for a mixture at exactly 50:50, no mixture will then be self-sustaining because there is none without a minority, and if the minority evacuates, complete segregation occurs. If both blacks and whites can tolerate minority status but there is a limit to how small a minority the members of either color are willing to be--for example, a 25 percent minority--initial mixtures ranging from 25 to 75 percent will survive but initial mixtures more extreme than that will lose their minority members and become all of one color. And if those who leave move to where they constitute a majority, they will increase the majority there and may cause the other color to evacuate.

Evidently if there are lower limits to the minority status that either color can tolerate, and if complete segregation obtains initially, no individual will move to an area dominated by the other color. Complete segregation is then a stable equilibrium. The concerted movement of blacks into a white area or whites into a black area could achieve some minimum percentage; but in the absence of concert, somebody has to move first and nobody will.

The following two sections of this memorandum are abstract explorations of some of the quantitative dynamics of segregating behavior. The first (Section II) is a spatial model in which people--actually, not "people" but items or counters or units of some sort--distribute themselves along a line or within an area in accordance with preferences about the composition of their neighborhoods. In this model there are no objective neighborhood boundaries; everybody defines his neighborhood by reference to

his own location. An individual moves if he is not content with the color mixture of his neighborhood, moving to where the color mixture does meet his demands. For simplicity, everyone of a given color has the same preferences regarding the color mixture of his own neighbors.

In the next model (Section III) space is compartmented. People are either in or out of a common neighborhood; those in it all belong to the same neighborhood irrespective of their particular location within it; and what matters to everybody is the color ratio within the whole neighborhood. In that model we allow variation in the preferences of individuals, some being more tolerant than others, some perhaps having a preference for integration. We look there at the question, what distribution of preferences or tolerances among the individuals of a given color may be compatible or not compatible with dynamically stable mixtures, what effect the initial conditions and the dynamics of movement will have on the outcome, and what kinds of numerical constraints may alter the results.

## II. SPATIAL SEGREGATION: A PROXIMITY MODEL

The results of this section are experimental. They are at this stage crude but have the advantage that anyone can reproduce them using materials that are readily available. (It is intended to generate a more statistically significant simulation with the help of a computer.)

I assume a population exhaustively divided into two groups; everyone's membership is permanent and recognizable. Everybody is assumed to care about the color of the people he lives among and able to observe the number of blacks and whites that occupy a piece of territory. Everybody has a particular location at any moment; and everybody is capable of moving if he is dissatisfied with the color mixture where he is. The numbers of blacks and whites, their color preferences, and the sizes of "neighborhoods" will be manipulated.

I am going to put my population into a stylized two-dimensional area. But the general idea is vividly displayed by distributing individuals along a line. There is some fascination in the process as it emerges in the linear model; furthermore, the linear experiment can be replicated by any reader in five minutes; variants can readily be devised, and any reader with a spare half hour can change the hypotheses to suit himself.

### LINEAR DISTRIBUTION

The line of stars and zeros in Figure 1 corresponds to the odd and even digits in a column of random numbers. It turns out that there are 35 stars and 35 zeros, and they look reasonably "random." (There is no need to test for oddities and regularities; it is easier to replicate the experiment from other columns in any table of random numbers.) We interpret these stars and zeros to be people spread out in a line, each concerned about whether his neighbors are stars or zeros.

We expect the stars and zeros to be evenly distributed in the large but unevenly in the small. If stars and zeros are content to live together in a ratio of about 50:50, each finds himself in a satisfactorily mixed neighborhood if he defines his neighborhood as a long enough stretch of the line. If instead everybody defines "his neighborhood" as his own house and the two neighbors next to him, a quarter of the stars and zeros are going to be "surrounded" by neighbors of opposite color. Satisfaction depends on how far one's "neighborhood" extends.

Suppose, now, that everybody wants at least half his neighbors to be like himself, and that everyone defines "his neighborhood" to include the four nearest neighbors on either side of him. A star wants at least four of his eight nearest neighbors to be stars; a zero wants at least four of his eight nearest neighbors to be zeros. Including himself, this means that he wants a bare majority, five out of the nine. (For those near the end of the line the rule is that, of the four neighbors on the side toward the center plus the one, two or three outboard neighbors, half must be like oneself.)

0+000+0+00++00+++0++0++00++00++00++0+0+00+++0++00000+++000+00++0+0++0

Figure 1

I have put a dot over each individual whose neighborhood does not meet his demands. Eleven stars and 13 zeros are dissatisfied with their neighborhoods. (The expected number is just under 13.)

Now we need a rule about how they move. Let me specify that a dissatisfied member moves to the nearest point that meets his minimum demand--the nearest point at which half his neighbors will be like himself at the time he arrives there. "Nearest" means the point reached by passing the smallest number of neighbors on the way; and he merely intrudes himself between two others when he gets there. We also need an order of moving; arbitrarily

let the discontented members move in turn, counting from left to right. The star second from the left moves first, the star sixth from the end moves second, and so forth.

Two things happen as they move. Some who were content will become discontent, because like members move out of their neighborhoods or opposite members move in. And some who were discontent become content, as opposite neighbors move away or like neighbors move close. The rule will be that any originally discontented member who is content when his turn comes will not move after all, and anyone who becomes discontent in the process will have his turn after the 24 original discontents have had their innings. The definition of the neighborhood is the four nearest neighbors on either side at the moment one decides to move or to stay; if someone moves in between a man and his next neighbor, the fourth neighbor away ceases to be a neighbor because he is now fifth.

Nobody in this model anticipates the movements of others. When it is his turn to move, he moves if his neighborhood demands are not met where he is and stays if they are, without regard to what he could anticipate if he studied the prospective decisions of others whose turns come later.

Applying these rules, the first discontented man on the left (the star located second from the end) moves to the right, passing six neighbors, and inserts himself between the zero who was eighth from the end and the star who was ninth. He now has two stars among the four neighbors to the left of him and two among the four to the right. The next to move is the star who used to be fifth from the end; he moves over to the right of the star that moved first and is followed by the star who was to his right, who moves over to the right of him. Next the discontented zero moves, and he moves to the left, passing four stars along the way. (Rightwards he would have had to move a greater distance.)

And so forth. The result is the top line in Figure 2, containing eight newly discontent individuals. We now



give them their turn; and they rearrange themselves to form the bottom line in Figure 2, in which everybody is content. (There is no guarantee that two rounds will put everybody in equilibrium. One round may do it, more than two may be required.)

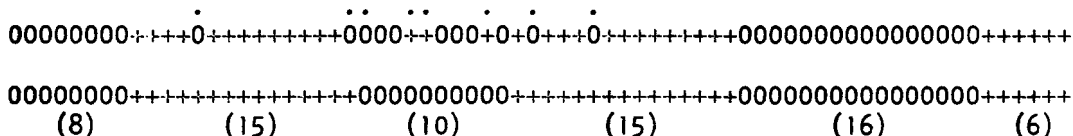

Figure 2

The result is six clusters of like individuals, containing 8, 15, 10, 15, 16 and 6 members respectively. The average size of a cluster is approximately 12 members.

If we count the like and opposite neighbors among the eight belonging to each of the 70 individuals, we find that 440 out of 540 neighbors are of the same color, or 81.5 percent. Counting himself as the ninth member of his neighborhood, everyone lives in a neighborhood in which his own color predominates by an average ratio somewhat greater than five to one. This resulted from individuals' seeking a ratio not less than five to four.

We knew in advance that, if there were an equilibrium, everyone would get to live in a neighborhood at least five-ninths his own color. We knew, or could easily have discovered, that equilibria existed. We could have surmised that our rules of movement would lead to equilibria, because each person's search for others of like color raises the likelihood that people of like color will stay in the place he moves to and those of opposite color will leave it. We got a more striking result.

Notice that regular alternation of stars and zeros would satisfy everybody with exactly half his neighbors of like color. So would alternating pairs: two zeros; two stars, two more zeros, etc. Alternating groups of three or four would not meet the condition; but any groups of five or more in alternation meet it. We got groups of about twelve.



ratio of stars to zeros in the total population, rules governing movement, and original configuration.

If we reduce neighborhood size, we get the same general pattern of alternating clusters (which we could call "alternating homogeneous neighborhoods" except that they do not correspond to "neighborhoods" as the members define them). Testing with the two random sequences that we have already used, defining the neighborhood as three people on either side of a resident, we find 37 initial discontents in the first case, 5 new discontents after the first round of moving, and an end result of ten groups with an average size of 7. The second sequence generates 29 discontents, 3 new ones after the first round, with an end result of seven clusters averaging 10 per cluster. Further experiment suggests a mean of 7 or 8 per cluster, or approximately twice the minimum size of cluster that meets the demand (alternating clusters of 4) and with the average person's neighborhood 75 to 80 percent his own color.\*

To illustrate what happens if we have unequal totals of zeros and stars, I have eliminated 17 of the 35 zeros in our first sequence (from Figure 1), letting a roll of the die determine the fate of each zero. Different rolls of the die will get you different reduced sequences; Figure 4 shows the one that I got.

..... ..  
+000+++00++0+++0+++0+++0+++00++0+++0++++0+++++00+++0+0+++0++

Figure 4

\*A curious property of this six-neighbor neighborhood is that, short of clusters of 4 or more, the only pattern that meets the demand for half one's neighbors like himself is ...00+0++0+00+0++.... Even this one is unstable at the ends: it must run indefinitely in both directions or form a closed curve, else it unravels completely into clusters.

All the zeros are now discontent, and three of the stars. Defining the neighborhood again as the four on either side and using the familiar rules of movement, all the zeros congregate in the first round, as in Figure 5.

+++++0000000000000000+++++  
(15) (18) (20)

Figure 5

Again rolling dice to eliminate about half the zeros from our second sequence (that of Figure 3), yielding again a ratio of about two stars for every zero, I found 18 of 20 zeros discontent and 2 of the stars. After a round of moving there were still 4 discontented members, and after a second round, 2. After the third round, the top line of Figure 6 was obtained. Using the same original sequence, but another random deletion, and again another random deletion from the same original, the other two lines of Figure 6 were obtained.

+++++000000000+++++00000+++++00000  
+++++000000000+++++0000000000+++++  
+++++000000000000000+++++

Figure 6

As the numerical inequality of majority and minority becomes more extreme, one expects the segregation (or "segregatedness") of the majority to become more extreme--there aren't enough of the minority to go around. If stars outnumber zeros by four to one, even a regular distribution will give stars an average of but one-fifth neighbors of opposite color. Furthermore, since the minimum size of segregated cluster that will satisfy the minority's demands for one-half neighbors of like color is

5, the minimum clustering among the majority that would satisfy the minority is 4 x 5, or 20.

What is less immediately apparent, but becomes apparent on reflection, is that the minority itself tends to become more segregated from the majority, as its relative size diminishes. That is, the minority clusters become absolutely larger as the minority itself becomes smaller. Or, to put it differently, as the relative size of the minority is diminished, the number (frequency) of minority clusters diminishes more than proportionately.

The reason is not too obscure: as the randomly distributed minority diminishes in proportion to the total population, the likelihood of four or more members of the minority among any eight consecutive individuals diminishes more than proportionately; so the number of potentially stable clusters ("growth nodes") declines relative to the minority population. Since everybody, under our rules of movement, travels to a place where at least four of eight individuals are his own color, they all end up together at places where at least four out of eight originally coincided by chance. Even demanding but three neighbors of like color, a 10 percent minority will form clusters averaging about twice the size of those obtained in Figures 2 and 3; demanding half, the mean cluster of a 10 percent minority will contain upwards of 100 if the aggregate population is large enough to sustain any growth nodes at all.

#### RESTRICTED MOVEMENT

A related point is interesting. Suppose the minority becomes relatively small, say 20 or 10 percent, still with initial random distribution, and we impose a limit on travel distance. Some, probably many, perhaps all, will become unable to move to where their demands are satisfied.

We then modify the rule: if a neighborhood half your own color does not occur within the allowed radius of travel, move to the nearest place where three out of eight occur. The result is that everybody achieves his desired neighborhood, half or more his own color, without traveling as far as if he and the others had been free to travel! The limitation on travel channels them into the smaller, more frequently occurring, potential clusters ("growth nodes"), which proceed to grow into clusters that more than satisfy them. Thus travel restrictions imposed on individual movement can be a substitute for concerted movement. It can also be a substitute for anticipatory movement, in which a person stops among three fellows of like color knowing, as he makes it four, that a fifth will soon arrive and stay.

All of this is much too abstract and artificial to be a motion picture of whites and blacks or boys and girls choosing houses along a road or even stools along a counter, but it is suggestive of a segregating process and illustrates some of the dynamics that could be present in individually motivated segregation.

#### AREA DISTRIBUTION

A convenience of the linear model was that, when we moved a person (or a counter) from a spot between two neighbors to a spot between two other neighbors, everybody could just move over to make room or to close up the vacant space, and the linear order was preserved. To do the same in two dimensions is not so easy; we need a rule about who moves over in which direction to make room for the newcomer or to close up a vacated space. A convenient way to meet the problem is to deal with absolute space rather than relative position: divide the area into a fixed number of spaces, leaving some vacant; a person can move only into a vacant space, and when he moves he leaves

a space vacant. "Neighborhood" is defined in terms of neighboring spaces.

To be specific: divide the area into squares like a checkerboard (but without any alternating colors) and distribute colored chips at random among the squares, leaving some squares blank. One chip occupies one square, and a "neighborhood" is defined by reference to the surrounding squares; each square on a checkerboard has eight immediate neighbors, so a convenient minimum-sized neighborhood for an individual is his own square plus the eight surrounding; larger "neighborhoods" can be considered by including the 24 surrounding squares in a 5 x 5 area, etc. An actual board, in contrast to a conceptually infinite expanse, has sides and corners; but, then, so probably do most natural areas, and this may be no disadvantage. Along the edge of the board a square has only five neighboring squares, and in a corner but three. The whole area need not itself be square; convenience may dictate some other shape, and if one wants to study the influence of natural boundaries a long and narrow checkerboard six squares wide and twenty long will have a higher proportion of residents on the edge than a square one.

In order that people be able to move there must be some vacant spaces; in order that they have significant choice of where to move there must be quite a few. While it is interesting to study what happens if the supply of vacant spaces is restricted, unless one is actually studying the influence of restricted supply the vacancies need to be a reasonably high proportion of the total. It turns out that 25 to 30 percent vacancies allows fair freedom of movement without making the board too empty.

The rule of movement, then, is that an individual discontent with his own neighborhood moves to the nearest vacant spot that surrounds him with a neighborhood that

meets his demands. In most of what I'm going to show you, "neighborhood" has been defined as the eight surrounding squares that, together with one's own square, form a 3 x 3 square. Color preferences with respect to one's neighborhood can be defined either in absolute terms--the number of one's own color within the eight surrounding squares--or in relative terms--the ratio of neighbors of one's own color to opposite color among the eight surrounding squares. If all squares were occupied, every absolute number would correspond to a ratio; but because one may have anywhere from zero up to eight neighbors, there are eight denominators and therefore eight numerators to specify in describing one's neighborhood demands.

As in the linear model, I make an initial distribution at random. It might make sense to distribute the blank spaces evenly, but I let them be determined at random, too. (It makes some difference.) In some cases I use equal numbers of blacks and whites, in others a ratio of two to one or larger. I then specify for each of the colors what its neighborhood demands are. I specify the rule for moving, which is usually to move to the nearest satisfactory square, with "nearest" measured by the number of squares one traverses horizontally and vertically. And we need a rule to specify the order in which they move; this part is more complicated than in the linear model. In some cases the order of move was determined merely by position on the board; such as working generally from left to right; it is also interesting to see what happens if all of one color completes its moves before the other color moves. It is possible, of course, to test the sensitivity of the results with respect to the order of moves. Because what is reported here has all been done by hand and-eye, no exact rule for the order of moves has been adhered to strictly.



As a start, we can use some of the same parameters as in our first linear model: equal numbers of stars and zeros distributed at random among the squares, with a suitable fraction left blank for ease of movement; "neighborhood" defined as the eight surrounding squares; and a universal demand that no fewer than half of one's neighbors be of the same color, the discontent moving to the nearest satisfactory vacant square.

Figure 7 shows an initial random distribution. There are 13 rows, 16 columns, 208 squares (for reasons of convenience that I won't go into here). It might seem unnecessary to reproduce an actual picture of randomly distributed stars and zeros and blank spaces; but some of the results are going to be judged impressionistically, and it is worthwhile to get some idea of the kind of picture or pattern that emerges from a random distribution. If one insists on finding "homogeneous neighborhoods" in this random distribution, he can certainly do so. Randomness is not regularity. If we are going to look at "segregated areas" and try to form an impression of how segregated they are, or an impression of how segregated they look, we may want a little practice at drawing neighborhood boundaries in random patterns.

Patterns, though, can be deceptive, and it is useful to have some measures of segregation or concentration or clustering or sorting. One possible measure is the average proportion of neighbors of like or opposite color. If we count neighbors of like color and opposite color for each of the 138 randomly distributed stars and zeros in Figure 7, we find that zeros on the average have 53 percent of their neighbors of the same color, stars 46 percent. (The percentages can differ because stars and zeros can have different numbers of blank neighboring spaces.)

There are, of course, many regular patterns that would yield everybody a set of neighbors half his own

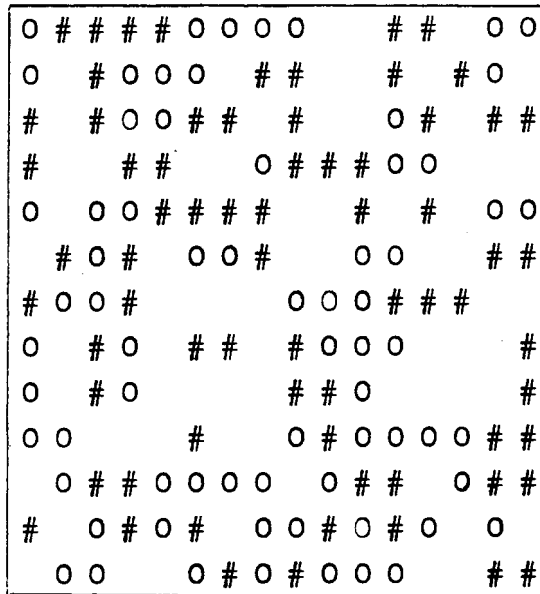

Figure 7

color and half the opposite color. Neglecting blank spaces for the moment, a checkerboard pattern will do it; alternate diagonal lines of stars and zeros will do it; dividing the board into 2 x 2 squares of four cells each, and forming a checkerboard out of these four-cell squares, will also yield everybody four neighbors of like color and four of opposite. And so forth. Patterning is evidently related to, but distinct from, any measures of neighborhood homogeneity that we may work out.\*

Now play the game of solitaire. Identify the discontents--there are 25 stars and 18 zeros in Figure 7 whose neighbors are less than half of like color--and, in some order, move them to where they are content, continuing to move the newly discontent until the entire board is in equilibrium. (There is no guarantee that everybody can find a blank space that suits him, but with the numbers we are using now it usually turns out that he can.) The particular outcome will depend very much on the order in which discontented stars and zeros are moved, the character of the outcome not very much. The reader can check this for himself in about ten minutes if he has a roll of pennies, a roll of nickels, and a sheet of paper big enough for 16 columns of one-inch squares.

Working generally from the upper-left corner downward and to the right, an equilibrium was achieved as shown in Figure 8. Working from the center outwards, the same initial distribution led to the equilibrium of Figure 9. The "segregation" in Figure 8 is too striking to need comment. In Figure 9 it is also striking, though more fragmented. The pattern in Figure 9 stands out more if we draw some boundaries; this may be cheating a little, in making an apparent pattern stand out, but that is why I first pre-

---

\*Patterning--departure from randomness--will prove to be characteristic of integration, as well as of segregation, if the integration results from choice and not chance.

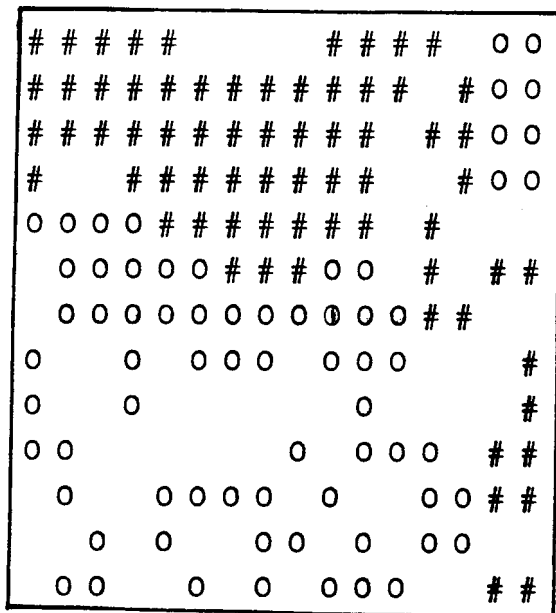

Figure 8

#	#	#	o	o	o		#	#	o	o				
	#	#	o	o	#		#	#	o	o				
#	#		#	#	#	#	#	#	#	#				
#	#	#	#	#		#	#	#	o	o	#	#		
	o	o	#	#	#	#	#		o	o	o			
o	o	o	o	#		#	o	o	o	o	#	#	#	
o	o	o	o	o	#		o	o	o	#	#			
o		o	o	#		o	o	o	o			#		
o	o	#	#			#	#	o	o	o		#		
o	o	#	#	#	#		#	#	o	o	o	o	#	#
	o	#	#	#	o	o	o	#	#		o	#	#	
	o		o	o	o	o	#	#	#	o	o	#		
o	o		o	o	o	o			o	#				

Figure 9

sented it without the boundaries and also why I suggested scrutinizing the random distribution to see that some "segregated patterns" emerged even there. Figure 10 is Figure 9 with some boundaries drawn in.

Though the patterns are impressionistic, the neighbor count is not. Originally, it will be recalled, the average percentage of like neighbors that the zeros had was 53, and stars 46. On the average, both colors were virtually at their minimum demands (as they were bound to be with equal numbers in total). But after the discontent have adjusted, and the newly discontent have then adjusted, and so on to equilibrium as in Figure 9, zeros on the average have neighbors who are five-sixths zeros, stars have neighbors who are four-fifths stars. On the average each zero has five neighbors, of whom (not quite) one is a star. Including himself, there are thus six people in the average zero's neighborhood, five his own color and one opposite. In the average star's neighborhood there are about four-and-a-half neighbors, one of whom is a zero; including himself, there are thus five-and-a-half residents of his neighborhood, one of whom is of opposite color.

Another statistic is the percentage of the population that has no neighbors of opposite color at all. In the random distribution of Figure 7 the number is 13 (which corresponds exactly to the expected value in an 11 x 16 matrix with one-third stars, one-third zeros, and one-third blanks). In Figure 9 the number is 54, or approximately 40 percent compared with 10 percent.\*

---

\*It may be helpful to compare the pattern of stars and zeros in Figure 9 with those of some standard reference pattern, such as rectangular blocks of stars and zeros on an unbounded checkerboard. The neighbor count of Figure 9 turns out to be identical with that obtained if stars and zeros occur in 7 x 7 squares of 49 each. (It should be kept in mind that 2 x 2 squares yield the same neighbor

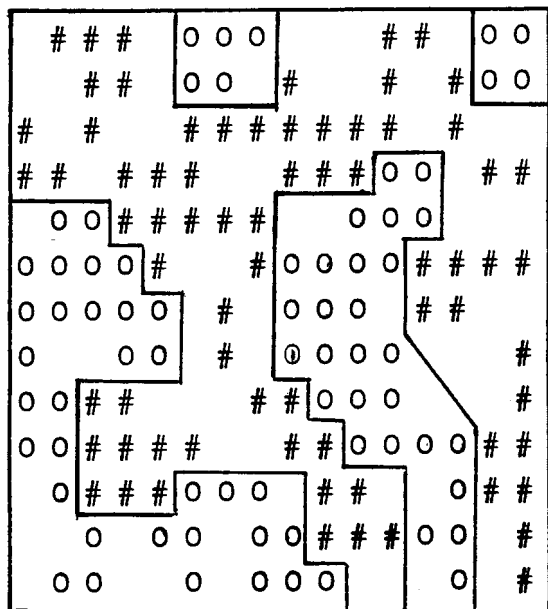

Figure 10

The figures are even more lopsided for Figure 8, where, counting himself, the average person lives in a neighborhood that is 90 percent his own color (89 for zeros, 91 for stars), and two-thirds of both colors have no neighbors of opposite color.

Now we can vary some parameters to see what we get. I shall not show any more initial distributions; they all involve the same 13 rows and 16 columns, blank spaces usually equal to about 30 percent of the total, and a random distribution of the two colors. We can vary the ratio of stars to zeros, the fraction or number of own color that stars and zeros demand, and in a few cases the size of the "neighborhood." We look, too, at the consequences of an actual preference for integration.

My samples have been too small, so far, to allow serious generalizations, so I shall formulate hypotheses suggested by what I have done. Quantitative measures, of course, refer exclusively to an artificial checkerboard and are unlikely to have any quantitative analogue in the living world. Comparisons among them, however, such as the effect of reducing or enlarging the size of a minority, may be capable of some extension to that world.

#### INTENSITY OF DEMAND FOR LIKE NEIGHBORS

If the two colors are equal in number, if neighborhoods are defined as the eight surrounding squares, and if both colors have the same demands for neighbors like themselves, the segregation that results is slight when the ~~count, one to one,~~ as expected in the random distribution.) Similarly, 3 x 3 squares are the smallest homogeneous groups in which someone has no neighbors of opposite color, the percentage for 3 x 3 being 11 percent, almost exactly that expected in a random distribution of the size and shape of Figure 7; the 39 percent without neighbors of opposite color in Figure 9 correspond to mono-colored 5 x 6 groupings on an unbounded surface (12 out of 30, or 40 percent).



demand is for about one-third of one's neighbors like oneself and striking when the demand is as high as one-half.

This result is both impressionistic and quantitative: the results are visually striking in the one case and not in the other, and the resulting ratios of like neighbors to opposite neighbors is upwards of four to one for demands of one-half or more, and less than 1.5 for demands of about one-third. See Figure 11, in which the demands are for about one-third.\*

An increase in the demand for like neighbors does three things. First, it increases the number that will be initially discontent. Second, it increases the like-color density that results from each movement: each individual that moves not only acquires more neighbors of like color the more he demands, but becomes a like neighbor to more neighbors the more he acquires. And, third, the greater the demands the more movement is induced by those that move on the part of those that were originally content. These three effects compound together to make the resulting segregation a rapidly rising function of demands in the range from about 35 to 50 percent.

When the demands of both colors are for 50 percent, their sum is of course 100 percent. Evidently for neighborhoods with fixed boundaries, no coexistence is possible if the demands of the two colors add up to more than one. In the present model there are not fixed boundaries, so it is possible to have mixed areas with everybody in the majority in his own neighborhood. But the degree of flexi-

---

\*Since the number of neighbors is a small integer, the fractions demanded for different numbers of neighbors have to differ. In Figure 11, the demands are for one like neighbor out of four or fewer, two out of five neighbors or more. The average number of neighbors in the initial distribution is five-and-one-half, the average number when equilibrium is reached is about four-and-a-half; the average effective preference is therefore in the neighborhood of one-third.

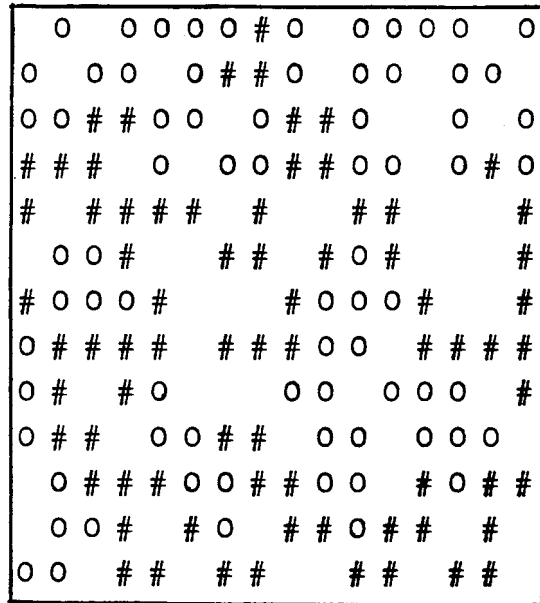

Figure 11

bility is not great. Therefore we should expect that demands summing to more than one should result in extreme segregation, as apparently they do.

#### UNEQUAL DEMANDS

If stars and zeros are about equal in number but one is more demanding than the other, the more demanding end up with a higher proportion of like neighbors, but not much higher. An illustration is Figure 12, in which the zeros (77) and the stars (72) are about equal in number but the zeros are less demanding. Zeros demand that one out of four or fewer be their own color, two out of five or more; stars demand two their own color if they have three, four or five neighbors, three if they have six or seven neighbors, and four out of eight. Zeros end up with a ratio of 2:1 of neighbors their own color, stars with the somewhat higher ratio of 2.5.

Any difference in these ratios is limited by the fact that the total of star neighbors of zeros has to equal the total of zero neighbors of stars; ratios for the two colors can differ only if stars have more or fewer stars as neighbors than zeros have zeros. The ratios differ, that is, only by different mean population densities in the neighborhoods of the two colors. Such a difference does occur but is limited, among other things, by the number of blank spaces on the board. With no blank spaces, the like-neighbor ratios for the two colors would be mathematically constrained to equality if the two colors were equal in number, and for unequal numbers would differ strictly as a function of their numerical ratios. (The percentage of neighbors of opposite color for the majority would be equal to that for the minority multiplied by the numerical ratio of the minority to the majority.)

#	#	#	0	0	0	0	0	#	#	0	0	0	
#	#	0	0	0	0	0	0	#	#	#	0	#	
#	0	0	0	0	0	#	#	#	#	#	#	#	
0	0	0	0	0	#	#	#	#	#	#	#	#	
#	0	#	#	#	#	#	#	#	#	#	#	0	
#	#	0	0	0	0	0	0	0	0	0	0	0	
#	#	#	#	#	0	0	0	0	0	0	0	0	
#	0	0	#	#	0	0	0	0	0	0	0	0	
#	0	0	#	#	#	#	#	0	0	0	0	0	
#	#	0	0	#	#	#	#	0	0	0	0	#	0
#	0	#	#	#	#	#	0	#	#	#	#	0	0
		0	0	0	0	0	#	#	#	#	0	0	0
0	0					0	#	#	#	0	0	0	0

Figure 12

UNEQUAL NUMBERS, EQUAL DEMANDS

If we put one of the two colors in minority status, letting it be outnumbered two to one or four to one, greater segregation occurs than with equal numbers, for any given set of demands on the part of the two colors. When one of the colors numbers only half the other, demands for about one-third neighbors of like color lead to ratios close to two to one for the minority (and, necessarily, still higher for the majority).

Figure 13 illustrates this effect. Stars outnumber zeros about two to one; demands are identical--a minimum of two neighbors of like color. The effective "demand" averages about 35 percent. The zeros, whose ratio of like to unlike neighbors in a random distribution is about 1:2, end up with the ratio reversed, 2:1, a four-fold increase in ratio. Stars went from an initial ratio of 2:1 to a ratio of 4:1.

With extreme color ratios, like five to one or more, the minority tends to display a phenomenon related to its absolute density rather than its relative density. We observed this earlier in the linear model. The proportion of initially satisfied individuals is so small that nearly everybody in the minority moves. Everybody, furthermore, moves toward whatever cluster of like-colored individuals he can find; and the number of such clusters declines disproportionately as the minority becomes smaller. The result is that the minority forms larger clusters, large enough to cause even a tolerant majority to become locally dissatisfied.

An extreme case of this absolute-number principle is easily envisioned by supposing an area populated initially by one color alone, into which newcomers of opposite color enter one by one. The first is located at random and has no place to go; the best the second can do is to join

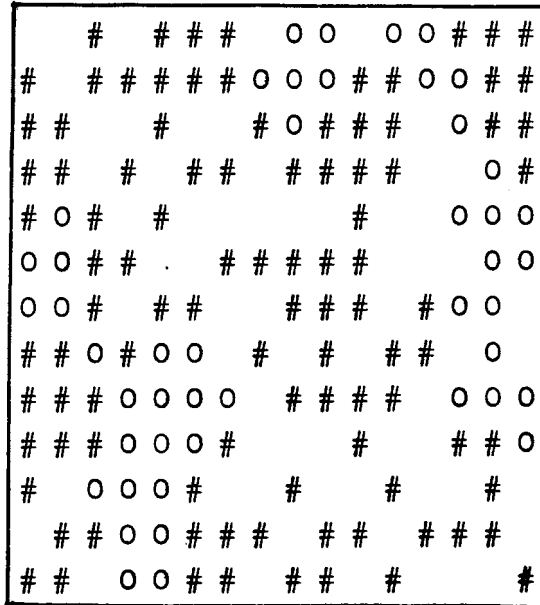

Figure 13

the first; the third, wherever he lands, if he wants any like neighbors at all, joins the first two, and similarly with the fourth and fifth and all who follow. In the end all the newcomers are together. Each has the choice between joining the only cluster or remaining entirely alone. If the available blank spaces permit them to achieve a significant density, the color initially resident will begin to vacate the locality of the cluster, and the result will be a solid neighborhood of the new color. This result will be independent of the moderateness of the color demands of the newcomers.

The process is illustrated in Figure 14, the upper part of which is an initial random distribution in which the stars outnumber the zeros by five to one. Neighborhoods were defined as the 24 surrounding squares; the zeros were given the rather moderate demand of an absolute number of two of like color in the 24 surrounding squares, stars the somewhat immoderate demand that zeros be no more than one-third of the population in the 24 surrounding squares. In the random distribution only a single star is dissatisfied, the one nearest to the lower right corner. The pattern that results from movement is somewhat sensitive to the precise order of movement imputed to the various dissatisfied zeros, of whom there are 11 out of the 15 individuals. The result that was actually obtained is shown in the lower part of Figure 14. The like-neighbor ratio for zeros can be computed on the basis of either 24 neighboring spaces or, for comparability with earlier results, 8. In the larger neighborhoods, zeros achieve two-fifths neighbors of like color, or a ratio of two to three; computed for the eight-neighbor neighborhoods, they achieve five-eighths, or a ratio of five to three.

Two more results are shown in Figure 15. In the top figure the zeros were given an even more moderate

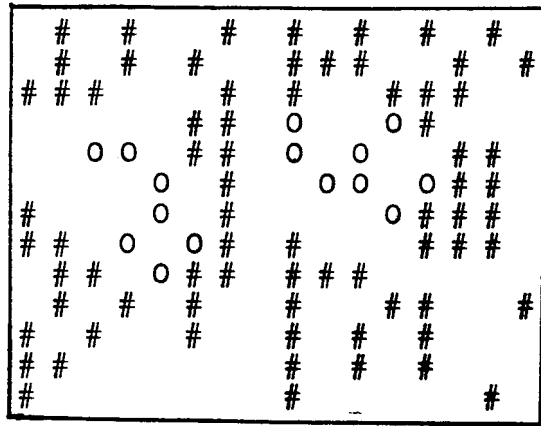
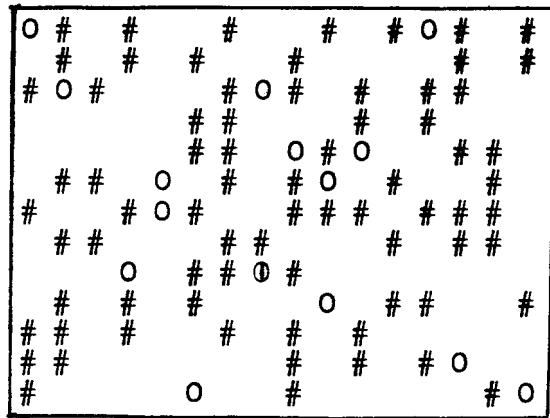

Figure 14



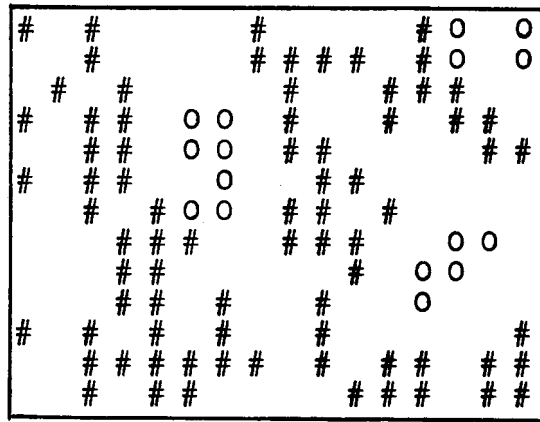
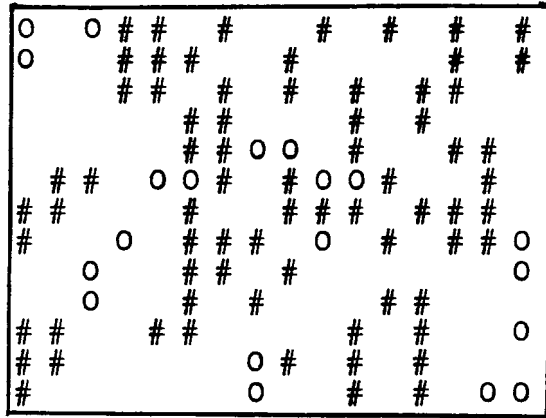

Figure 15

demand--two zeros among the 24 neighboring spaces or, if the total number of neighbors within the 24-space neighborhood does not exceed six, just one will do. Stars were again supposed to want no more than one-third zeros within their 24-space neighborhood.

The top part of the figure illustrates that the pattern of segregation is not always as distinct as in Figure 14. It also illustrates the precarious nature of some equilibria that are reasonably mixed. There is a large number of individuals of both colors who are barely satisfied, and just a little random turnover would cause a further round of sorting that would cause the zeros to cluster strikingly and many of the stars to evacuate the areas of cluster. The bottom of Figure 15 is based on the same demands as Figure 14--an absolute demand for two zeros among the 24 neighboring spaces.

#### POPULATION DENSITIES

An unexpected result--one that is not easy to rationalize, and that may or may not have residential significance in the real world but undoubtedly has ecological significance in some context--is in what the sorting does to the population densities of the individual neighborhoods. It will be recalled that with equal numbers of the two colors but different demands, the more demanding color ended with a higher ratio of like to opposite neighbors. This was possible because of a discrepancy in the average number of like neighbors acquired in the process by the two colors. That the more demanding ends up in more homogeneous clusters is mathematically equivalent to the result that the more demanding ends up with more neighbors, in more densely populated neighborhoods. This result was first recognized merely as a mathematical consequence of what appeared to be a discrepancy in the "segregatedness" between the more and the less demanding of the two colors.

Attention was called earlier to Figure 12 because stars had a somewhat higher ratio of like to opposite neighbors than zeros did, a ratio of 2.5 compared with 2.0. The same Figure illustrates the density phenomenon. Stars on the average, in that Figure, have 5.35 neighbors, zeros 4.55. Stars and zeros occupy similar numbers of border positions, so the difference is not due to a discrepancy in the number of neighboring spaces.

Actually the impression one gets in Figure 12 is that zeros are even more dispersed, and stars more compacted, than those numbers suggest. The reason is that many blank spaces are "neighbors" of other blank spaces, yet occur within territories that clearly "belong" to the zeros. Our "neighbor count," computed from the squares adjacent to stars and zeros, misses this phenomenon. The neighbor count is based on individual neighborhoods, not on any "collective neighborhoods" that we might identify. The pattern in Figure 12, however, tempts us to draw territorial boundaries, identifying regions occupied exclusively by zeros and regions occupied exclusively by stars. When the segregation is quite incomplete, it is by no means easy to do this; and alternative rules for drawing boundaries may lead to quite different results; but in Figure 12 the segregation is sufficiently marked to leave little to discretion. We can easily draw neat boundaries that completely separate stars from zeros, and we can furthermore impute blank spaces almost unambiguously to star territories and zero territories. If we do this we find the following. Splitting the blank spaces that might plausibly be imputed either to star territory or to zero territory, the 59 blanks divide into about 14 that we can impute to "star territory" and about 45 that we can impute to zeros. (Ten ambiguous blanks were divided five each in this calculation.) Including blank spaces "belonging" to them, the 72 stars occupy territory comprising 86 spaces alto-

gether, and a population density of .83 within that territory. The 77 zeros occupy territory comprising 122 spaces altogether, with a population density of .63. "Zero territory" is 37 percent vacant, "star territory" only 17 percent.

Figure 12 may display the density phenomenon to more than average degree, but it usefully introduces a notion of "collective territory," that appears to be a necessary supplement to the "individual neighborhood" in describing the outcome, even though it enters no one's motivation. A satisfactory definition of "collective territory," or whatever we choose to call it, will have to be developed, since in many cases the boundaries will be less obviously determined than in the case of Figure 12.

Population densities were then examined for the case of equal demands and unequal numbers, and an equally striking difference in population density showed up. The minority tends to accumulate in denser neighborhoods than the majority. Figure 13 displays the greater compactness of the minority. The mean number of neighbors per zero is 6.0, per star it is just under 5.0. And again one can draw rather unambiguous boundaries dividing stars from zeros--or "star territory" from "zero territory"--and find that zero territory has an occupancy rate of about 83 percent, star territory of about 64 percent. The vacancy rate in star territory is just over twice that in zero territory. (Four somewhat ambiguous blank spaces, in the fourth column from right-hand side, were allocated two each to star and zero territory.)

A more extreme result is obtained when one group is both smaller in numbers and more demanding as to neighbors. In Figure 16 the ratio of stars to zeros is almost four to one; stars demand one star out of four or fewer neighbors, two out of five or more, while zeros demand two out of

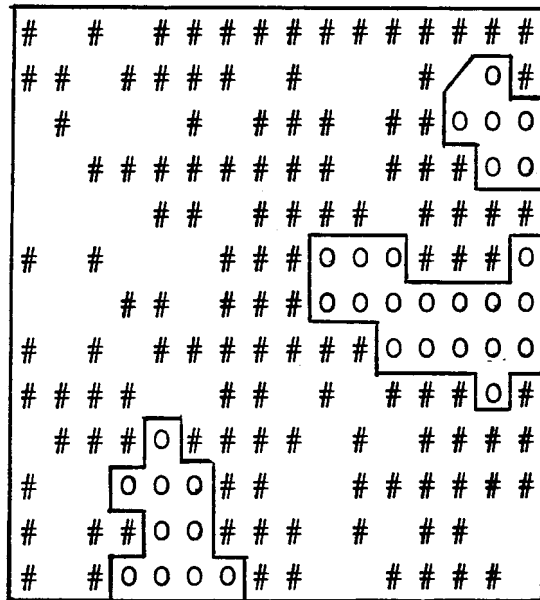

Figure 16

five or fewer, three out of six or seven, four out of eight. In addition to rather striking separation of the two colors, there is virtually complete occupancy of "zero territory" amidst a quite dispersed star population. Stars average 5.1 neighbors apiece; zeros average 6.8, and, given their locations, 7.0 is the maximum.

The mechanism affecting density surely has a rationale, but not a simple one; it corresponds to no hypothesis that entered originally into the author's thinking. When machine simulation has generated larger samples and more dynamic-process data, both the motivation and the significance, if any, may become more apparent.

#### SIZE OF NEIGHBORHOOD

Enlarging the area within which a person counts his neighbors attenuates the tendency to segregate, at least for moderate demands and near-equal numbers of the two colors. This observation may not stand up when less tolerant demands, and greater differentials in initial numbers, are put into the larger neighborhoods.

#### "INTEGRATIONIST" PREFERENCES

The foregoing results all assume that members of both colors have certain minimum demands for neighbors of like color, but no maximum demands. We can experiment with a demand for "integration" either by supposing some preferred ratio, or by supposing that there is an upper as well as lower bound to the fraction of neighbors of like color that one wants. Figure 17 shows results from two different "integrationist" preference schedules. In both cases zeros are just over half the number of stars. In the top figure there is, for both stars and zeros, an upper as well as a lower limit to the number of like neighbors demanded: among eight neighbors, at least three and at

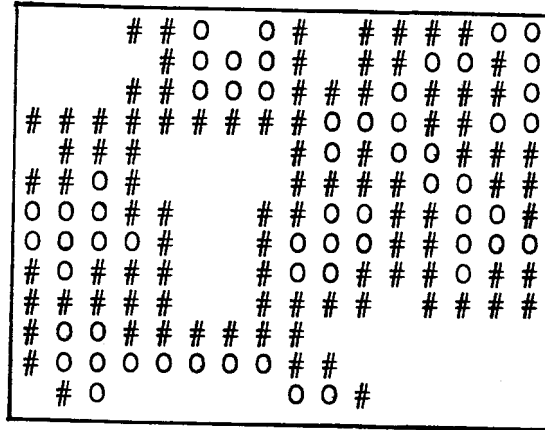
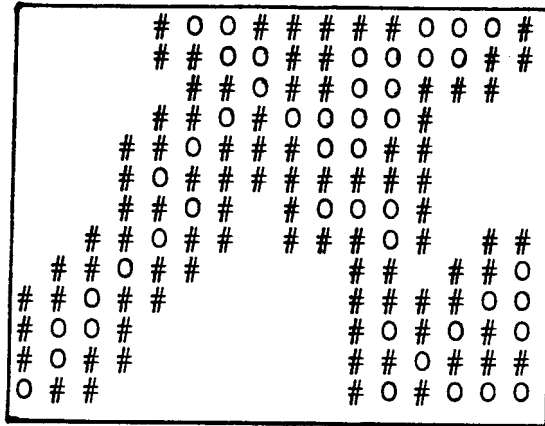

Figure 17

most six like oneself; among seven, at least three and at most five; among six at least three and at most four; among five at least two and at most four; among four either two or three; among three either one or two; and one out of two. In the bottom figure there is a scale of preferences rather than upper and lower limits: out of eight neighbors, five like oneself is the preferred number but, if the board offers no such choice, then four and six are equally preferred as second choice; failing that, three and seven are equally attractive, with two and eight tied for next place, then one and finally none. Similarly with other numbers of neighbors: half for odd numbers, just over half for even, with second and third choices pairing numbers both above and below the preferred number.

Tentative experimentation suggests three phenomena that are not present in the case of purely "separatist" demands:

a. Integration requires more complex patterning than separation; equilibrium is achieved only with a much larger number of moves; and a larger number of individuals move. More individuals may be incapable of being satisfied. And there are problems of the consistency of the integrationist demands, not only of the two colors but of each of them with the overall color ratio in the population.

b. If one of the colors is a minority, the two colors have to pattern themselves in such a way that the minority is "rationed." That is, the patterns have to be "efficient" in the way members of the majority can share minority neighbors. The result may look just as non-random as the segregated results achieved earlier; the patterns are as striking, but they are different patterns. The minority, for example, may be spread out in conspicuous lines rather



than clustered in conspicuously convex areas, as in Figure 17.

c. The process of moving produces "dead spaces." An area densely settled by either color will be evacuated in its center; neither color will then move into the area, but the boundary is stable because it has contact with the opposite color. The result is that the blank spaces form their own "clusters" in the final equilibrium, giving an appearance quite different from that produced by purely separatist motives.

### III. A BOUNDED-NEIGHBORHOOD MODEL

We turn now to a different model, with a changed definition of "neighborhood." Instead of each individual's defining his neighborhood by reference to his own location, there is a common definition of the neighborhood and its boundaries. A person is either inside or outside the neighborhood. Each individual is concerned about the color ratio within the neighborhood but not with any configuration of the colors within the neighborhood. "Residence" in this model can therefore just as well, perhaps even better, be interpreted as membership or participation --in some organization, occupation or activity.

In this model there is one particular bounded area that everybody, black or white, prefers to any of its alternatives. He will reside in this area unless the percentage of residents of opposite color exceeds some limit. Each individual, black or white, has his own limit, or "tolerance," as we shall occasionally call it. If a person's own limit is exceeded in this area he will go someplace else--a place, presumably, where his own color predominates or where color does not matter.

"Tolerance," it should be noticed, is a comparative measure, specific to this location. Whites who appear, in this location, to be less tolerant of blacks than other whites may be merely more tolerant of the alternative locations available.

The higher the limits, the more blacks and whites would be content to live together in the area. Evidently the upper bounds must be compatible for some blacks and some whites--specifically, as ratios their products must not be less than 1, as percentages they must add to at least 100--or no contented mixture of any whites and blacks in this area is possible. Evidently, too, if nobody can tolerate extreme ratios, an area initially occupied by one

color alone would remain so. There may be some number among the other color that, if concerted entry were achieved, would remain; but, acting individually, nobody would be the first.

We can experiment with frequency distributions of "tolerance" to see what results they lead to. We cannot discover realistic distributions because they depend on the area in question; and the area in the model is unnamed. What we can do is to look at the process by which the area becomes occupied, or remains occupied, by blacks or whites or a mixture of both, and look for some general principles that relate outcomes to the shapes of the curves, the initial positions, and the dynamics of movement.

We assume that all preferences go in the same direction: a person need not care, but if he does his concern takes the form of an upper limit to the other color that can occur in this area without his choosing to go elsewhere. There is no lower limit: there are no minority-seeking individuals, nor any who will leave if the area is not suitably integrated. Absolute numbers do not matter, only ratios; there are no economies of scale in being among one's own color. There are no individual positions within the mix: nobody is near the center or near the boundary, nobody has a "next neighbor."

To study the dynamics we shall assume that people both leave and return. (This is restrictive: if the preference for this locality were due merely to the fact that some people were already here and the cost of leaving were high, that cost would not be recovered by returning.) People in the area move out if the ratio is not within their color limit; people outside move in if they see that it meets their requirements.

Information is perfect: everybody knows the color ratio within the area when he makes his choice. People do not, however, know the intentions of everybody else and do not project future turnover.

As to the dynamics of motion, we need not stipulate in advance whether whites move in or out more rapidly than blacks do. Their relative speeds of reaction will sometimes matter, and in our analysis we can watch and see how they matter. We need, though, the somewhat plausible assumption that, as between two whites dissatisfied with the ratio of white to black, the more dissatisfied leaves first--the one with the lesser tolerance. Then, as a result of sorting, the whites within the locality at any given time will all have higher tolerance of blacks than any of the whites outside, and similarly for blacks inside and outside. It is the least tolerant whites that move out first, and the most tolerant that move in first, and similarly for blacks.

Our initial data are represented by a cumulative frequency distribution of "tolerance" of the members of each color group. We can experiment with various hypothetical schedules of tolerance, but for the initial experiment we begin with a straight line.

#### AN ILLUSTRATIVE STRAIGHT-LINE DISTRIBUTION OF "TOLERANCE"

For the whites, the horizontal axis measures the number of whites, the vertical axis measures the ratio of blacks to whites representing the upper limits of their tolerances. We can take the total of whites to be 100. Suppose that the median white is willing to live with blacks in equal numbers, so that 50 among our 100 whites will abide a ratio of black to white of 1.0 or greater. The most tolerant white can abide a black-white ratio of two to one, that is, is willing to be in a one-third minority; and the least tolerant white cannot stand the presence of any blacks. The cumulative distribution of tolerances for a white population will then appear as in the top of Figure 18. It is a straight line with intercept

at a ratio of 2.0 on the vertical axis and intercept on the horizontal axis at the 100 whites who comprise the white population.

Suppose that blacks have an identical distribution of tolerance for whites, the median tolerance being a ratio of one to one, and that the number of blacks is half the number of whites, 50.

It is evident without further analysis that there are at least some whites and some blacks who could contentedly coexist. Fifty of the whites would be willing to live with all the blacks, though not all 50 blacks would be willing to live with 50 whites; but a mixture of 25 blacks and 25 whites, consisting of the more tolerant 25 blacks and 25 of the more tolerant 50 whites, would be content together. There are 10 blacks who could tolerate a ratio of 1.6 to 1, or 16 whites; and any 16 among the 80 or so whites who will tolerate a black-white ratio of 10:16 would be content to join them. To explore all the combinations that might form a contented mix, but especially to study the dynamics of entry and departure, it is useful to translate both our schedules from ratios to absolute numbers, and put them on the same diagram.

#### TRANSLATION OF THE SCHEDULES

This is done in the bottom of Figure 18. The curve labeled W is a translation of the white tolerance schedule. For each number of whites along the horizontal axis the number of blacks whose presence they will tolerate is equal to their own number times the corresponding ratio on the schedule of tolerance. Thus 50 whites can tolerate an equal number of blacks, or 50. Seventy-five can tolerate half their number, 37.5; twenty-five can tolerate 1.5 times their number, or 37.5. Ninety can tolerate but one-fifth their number, 18; twenty can tolerate 36, and so forth.

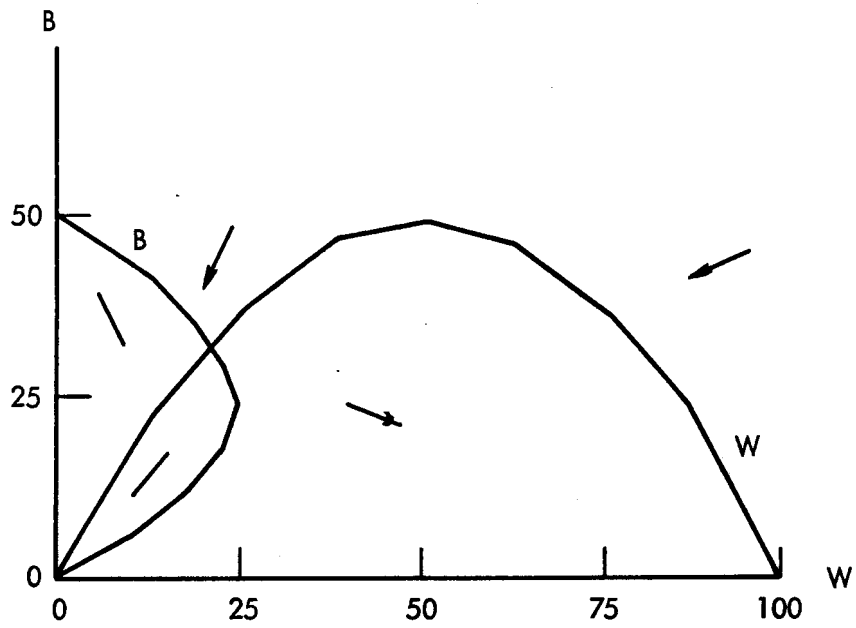
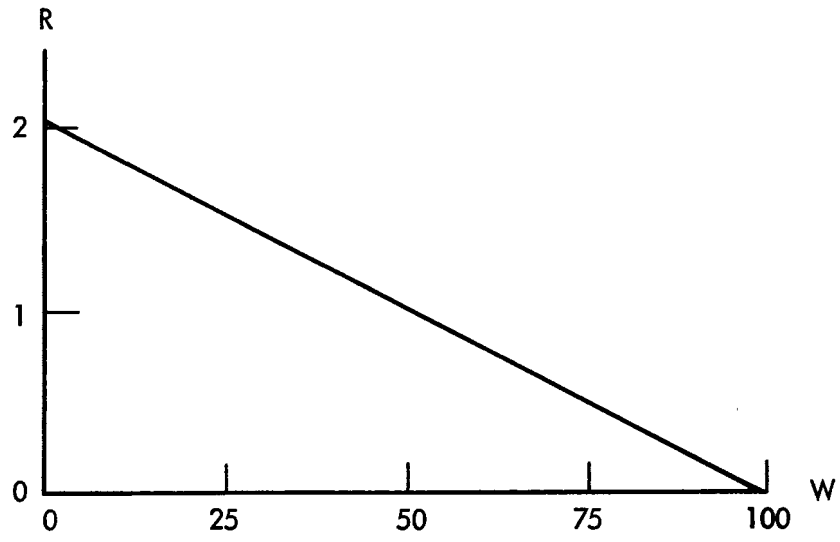

Fig. 18

In this fashion the straight-line tolerance schedule translates into a parabolic curve showing the absolute numbers that correspond to the limits of tolerance of alternative numbers of whites. (Economists will recognize that the cumulative frequency distribution of tolerance translates into this absolute-numbers curve in the same way that a demand curve translates into a total revenue curve.) Similar arithmetic converts the blacks' schedule of tolerance into the parabolic dish that opens toward the vertical axis in Figure 18.

#### STATIC VIABILITY

Any point in Figure 18 that lies within both parabolas (the area of overlap) denotes a statically viable combination of blacks and whites. There are that many whites who will abide the presence of that many blacks, and there are that many blacks who will abide the presence of that many whites. Any point on the diagram that is beneath the whites' curve but to the right of the blacks' curve represents a mixture of whites and blacks such that all the whites are contented but not all the blacks. Some of the blacks may be content, but not all those present. And a point on the diagram that lies outside both curves--the region to the upper right--denotes a mixture of whites and blacks at which neither all the whites nor all the blacks could be satisfied; some of both colors would be dissatisfied.

#### DYNAMICS OF MOVEMENT

It is the dynamics of motion, though, that determine what color mix will ultimately occupy the area. The simplest dynamics are as follows: if all whites present in the area are content, and some outside would be content if they were inside, the former will stay and the latter will enter; and whites will continue to enter as long as all

those present are content and some outside would be content if present. If not all whites present are content, some will leave; they will leave in order of their discontent, so that those remaining are the most tolerant; and when their number in relation to the number of blacks is such that the whites remaining are all content, no more of them leave. A similar rule governs entry and departure of blacks.

We can now plot, for every point on the diagram, the vector of population change within this area. Within the overlapping portion of the two curves, the numbers of blacks and whites present will both be increasing. Within the white curve but outside the black curve, whites will be coming into the area and blacks departing; the direction of motion on the diagram will be toward the lower right, and nothing stops that motion until all blacks have departed and all whites have come in. To the upper left, within the black curve but beyond the white curve, blacks will be entering and whites departing; and the process can terminate only when all the whites have left and all the blacks have come in. Mixtures denoted by points outside both curves, to the upper right, will be characterized by the departure of both colors; and when one of the colors is reduced to where it is within its own curve, continued departure of the other color will improve the ratio for the color within its own curve; those who left will begin to return, and the other color will evacuate completely.

There are only two stable equilibria. One consists of all the blacks' being present with no whites, the other with all the whites and no blacks. Which of the two will occur depends on how the process starts and, perhaps, the relative speeds of white and black movement. If initially one color predominates it will move toward complete occupancy. If initially some of both are present, in "statically viable" numbers, relative speeds of black and white



entry will determine which of the two eventually turns discontent and evacuates. If both are initially present in large numbers, relative speeds of exit will determine which eventually becomes content with the ratio, reverses movement, and occupies the territory.

There are, then, compatible mixes of the two colors-- any mixture denoted by the overlap of the two curves; the difficulty is that any such mixture attracts outsiders, more of one color or both colors, eventually more of just one color, so that one color begins to dominate numerically. A few individuals of the opposite color then leave; as they do, they further reduce the numerical status of those of their own color who stay behind. A few more are dissatisfied, and they leave; the minority becomes even smaller, and cumulatively the process causes evacuation of them all.

#### ALTERNATIVE SCHEDULES

This is, of course, not the only result. The outcome depends on the shapes we attribute to the tolerance schedules, and to the sizes of the white and black populations. With steeper straight-line schedules and equal numbers of blacks and whites we can produce a stable mixture with a large number of blacks and whites.

Specifically, suppose that the median white can tolerate a ratio of 2.5 blacks per white, i.e., will inhabit this area even if whites are a minority of 25 to 30 percent. Suppose the most tolerant white can accept a ratio of five to one and the least tolerant can stand the presence of no blacks. The tolerance schedule will be a straight line with a vertical intercept at 5.0. If the blacks are equal in number and have an identical distribution of tolerance for the presence of whites, the two schedules will translate into identical parabolas as shown in Figure 19.

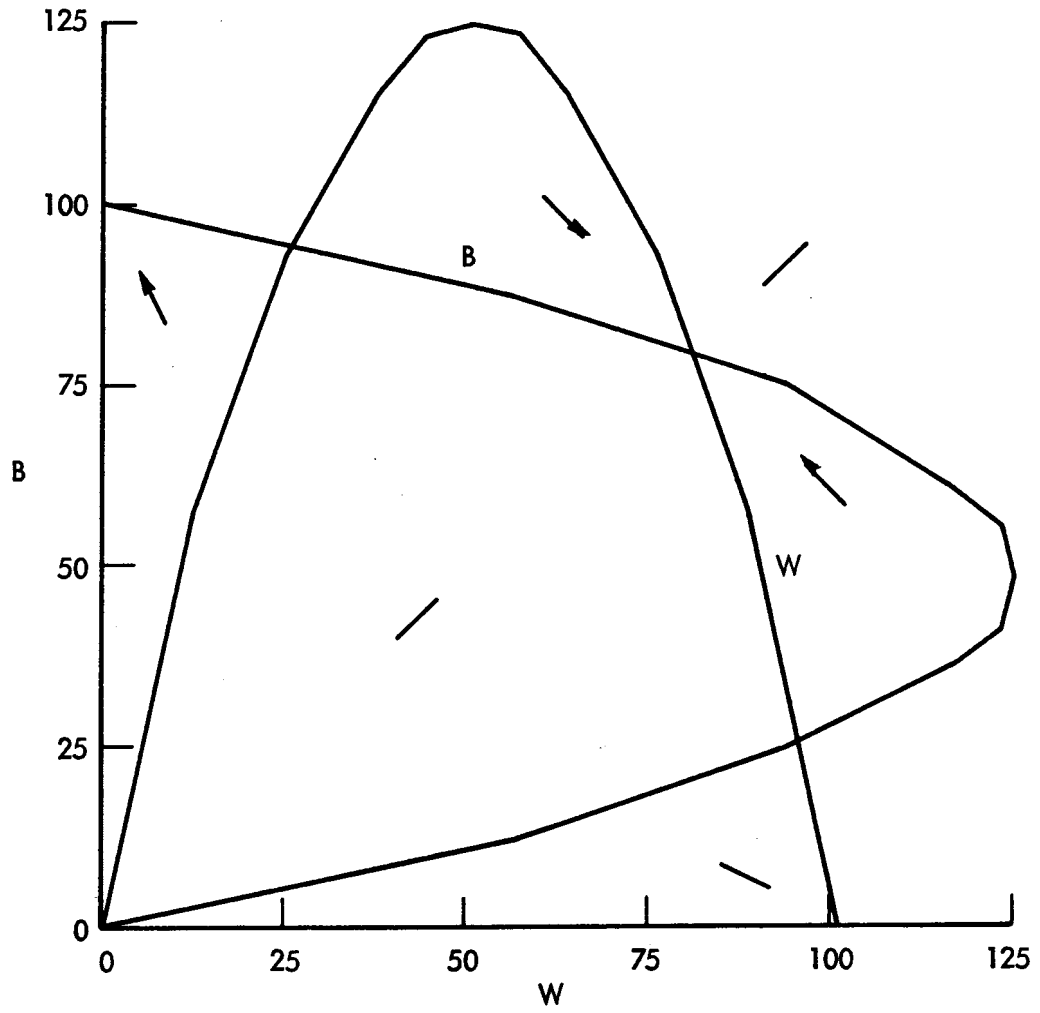

Fig. 19

Here, in addition to the two stable equilibria at 100 blacks and no whites and at 100 whites and no blacks, there is a stable mixture at 80 blacks and 80 whites. In fact, over a wide range of initial conditions it is this mixed equilibrium that will be approached through the movement of blacks and whites. As long as half or more of both colors are present--actually, slightly over 40 percent of both colors--the dynamics of entry and departure will lead to the stable mixture of 80 blacks and 80 whites. Even for very small numbers of both colors present, if the initial ratios are within the slopes of the two curves (which allow somewhat more than two to one of either color) and if neither color tends to enter much more rapidly than the other, the two colors will converge on the 80-80 mixture. Still, if the area were initially occupied by either color, it would require the concerted entry of more than 40 percent of the other color to lead to this stable mixture. Thus each of the three equilibria--the all-white, the all-black, and the 80-80 mixture--is stable against large perturbations.

#### ALTERNATIVE NUMBERS

The stable equilibrium generated in Figure 19 disappears if the total number of blacks exceeds that of whites or whites exceed blacks by, say, two to one. In that case one curve lies within the other curve, rather than intersecting it, as shown in Figure 20. Alternatively, leaving total numbers of blacks and whites equal, the stable equilibrium disappears if the straight-line tolerance schedules are made less steep; with the schedules that underlie Figure 18, equal numbers result in Figure 21. (For straight-line tolerance schedules and equal numbers of the two colors, there is no stable intersection of the two parabolas unless the tolerance schedules have vertical intercepts of 3.0, with median tolerance of 1.5.)

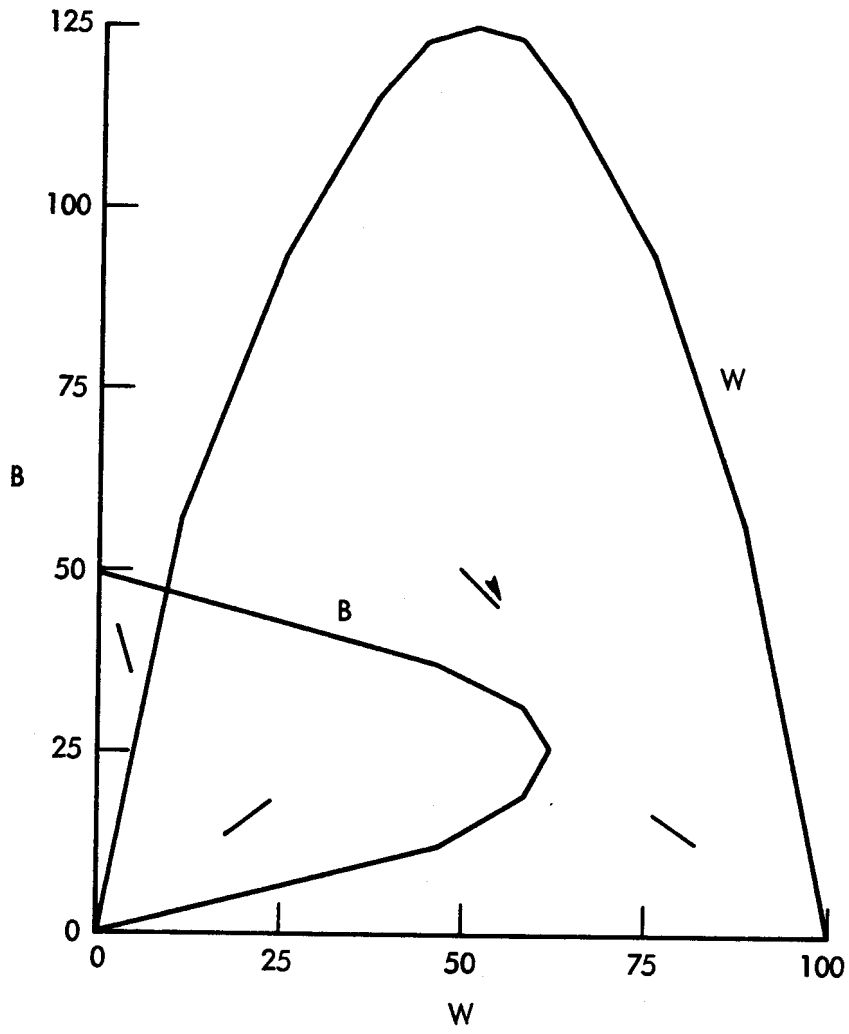

Fig. 20

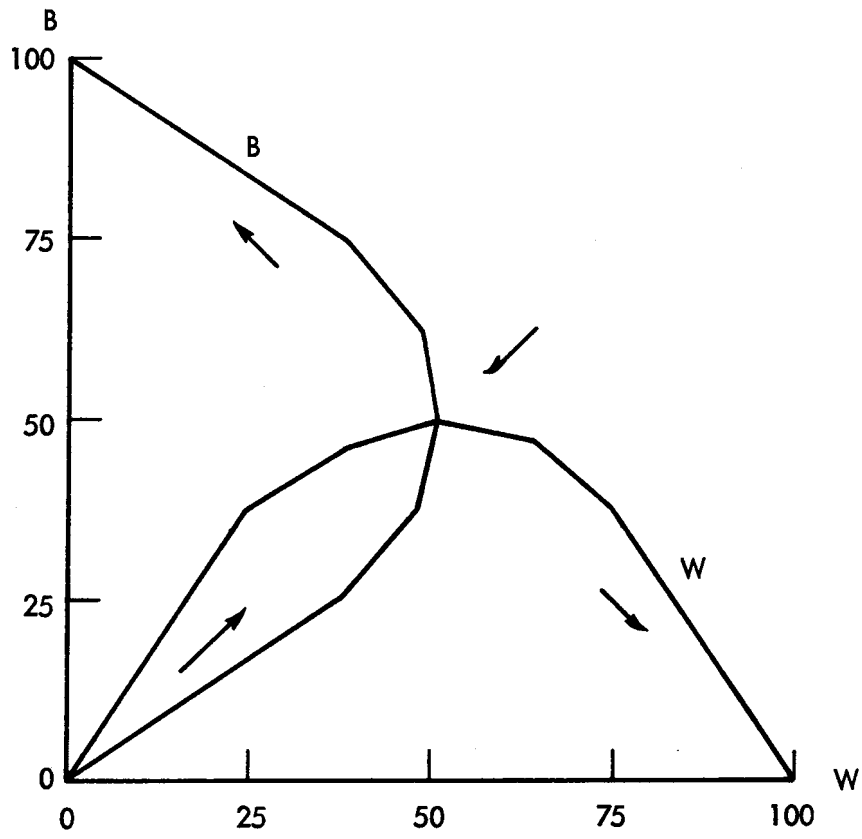

Fig. 21

### LIMITING NUMBERS

Limiting the numbers that may be present can sometimes produce a stable mixture. If the number of whites in the preferred area is limited to 40 and if the most tolerant 40 are always the first to enter and the last to leave, the curves of Figure 20 are replaced by those of Figure 22, with a stable mixture at 40 whites and a comparable number of blacks.

With the curves of Figure 18, however, the numbers of both colors would have to be restricted to yield the stable intersection shown in Figure 23. If the total number present can be restricted, but not the numbers of the two colors separately, we get a kind of neutral equilibrium along the 45-degree line shown in Figure 24. If there is "turnover" of the population, the mixture may drift toward a higher ratio of whites to blacks or a higher ratio of blacks to whites; and if it goes outside the overlapping portion of the two curves, the minority will evacuate.

It is interesting that the limitation on the number of whites that may be present has the same effect in our model as if the whites in excess of that number had no tolerance for any blacks at all: whether they are excluded, or merely exclude themselves, it is their absence that keeps the whites from overwhelming the blacks by their numbers and makes the stable mixture possible.

### VARYING "TOLERANCE"

Thus it is not the case that "greater tolerance" increases the likelihood of a stable mixture--at least, not if "greater tolerance" means that within a given population some members are statistically replaced by others more tolerant. On the contrary, replacing the two-thirds least tolerant whites by even less tolerant whites keeps the whites from overwhelming the blacks by their numbers.

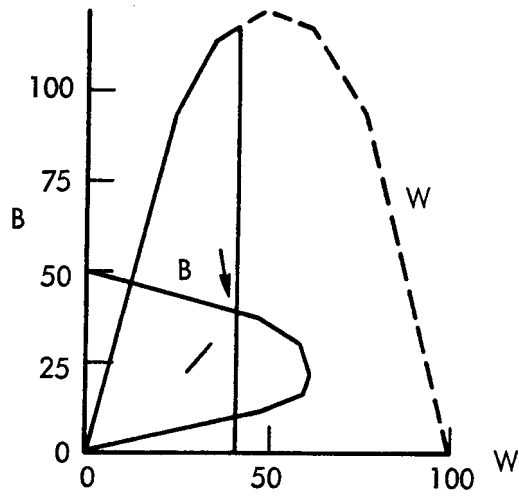

Fig. 22

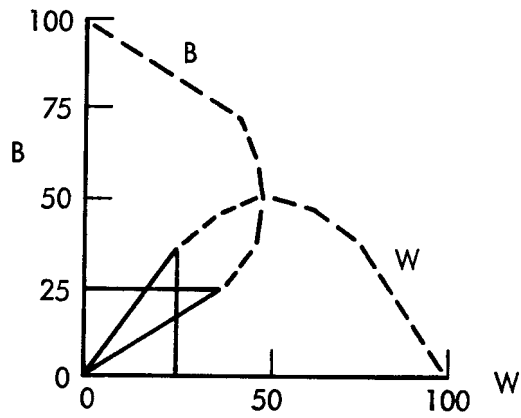

Fig. 23

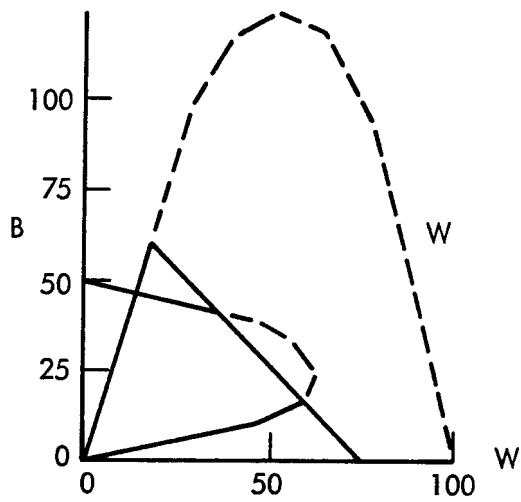

Fig. 24

This would not happen if we made all whites less tolerant. If we make the tolerance schedule of the whites merely less steep, thus shortening the whites' parabola in Figure 22, we do not get our stable intersection of curves. What is required, as we manipulate the tolerance schedule in search of a stable equilibrium, is that at our dividing point of 40 percent or so of the whites, the more tolerant whites just within that percentage figure remain as tolerant as they were and the less tolerant just beyond that figure become even less tolerant. (What happens to the very most tolerant and the very least tolerant makes little difference so long as they do not drastically change.) The ogive shape shown in Figure 25 is the kind that will produce the stable mixture when the blacks are outnumbered two to one with the curve of Figure 20.

#### VARIETIES OF RESULTS

Evidently there is a wide variety of shapes of tolerance schedules that we could experiment with and different assumed aggregate ratios of blacks and whites. While there is no room in this memorandum to explore a large number of combinations, the method is easy and the reader can pursue by himself the cases that most interest him. There are a few results that deserve to be summarized even though the analysis will not be shown.

1. The only logical restriction on the shape of a "tolerance schedule" is that it slope downward to the right; the only ensuing logical restriction on the shape of the absolute-numbers curves is that a ray from the origin intersect such a curve only once. Within this restriction it is possible to have curves that provide a single stable equilibrium, two stable equilibria, three or four or even more. The single one may be with one color exclusively present or with both colors present; two stable equilibria may be all-white and all-black, or one mixture



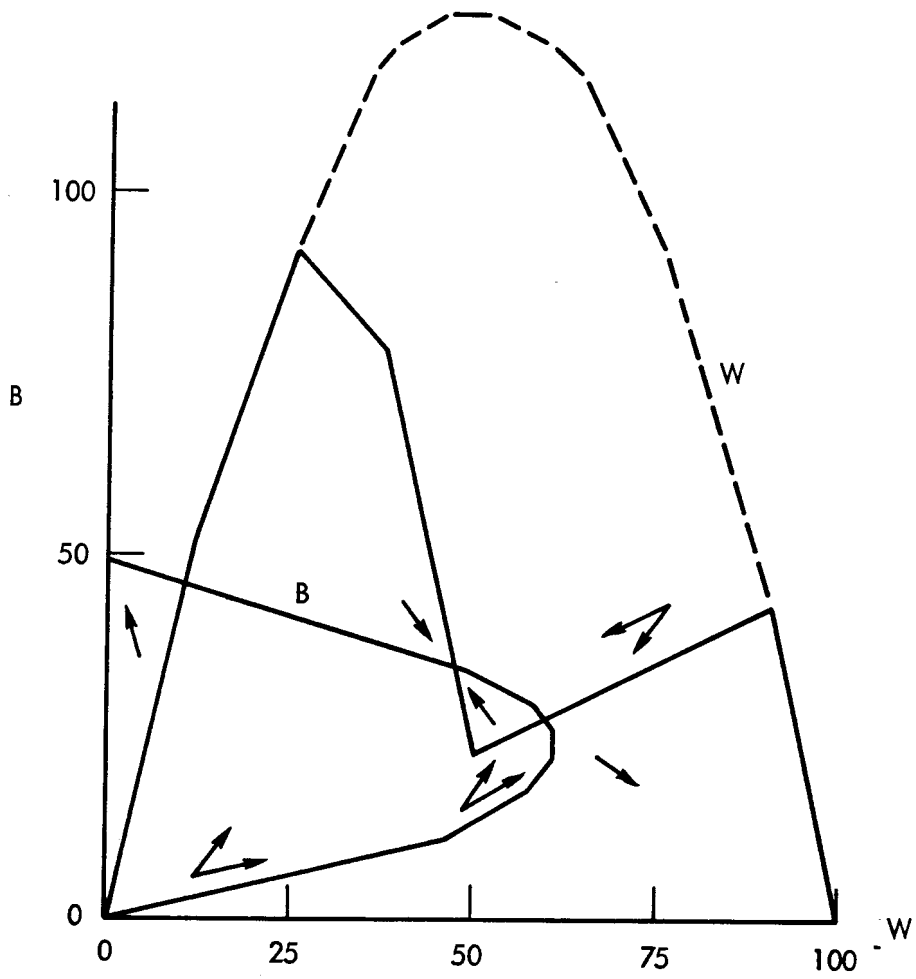
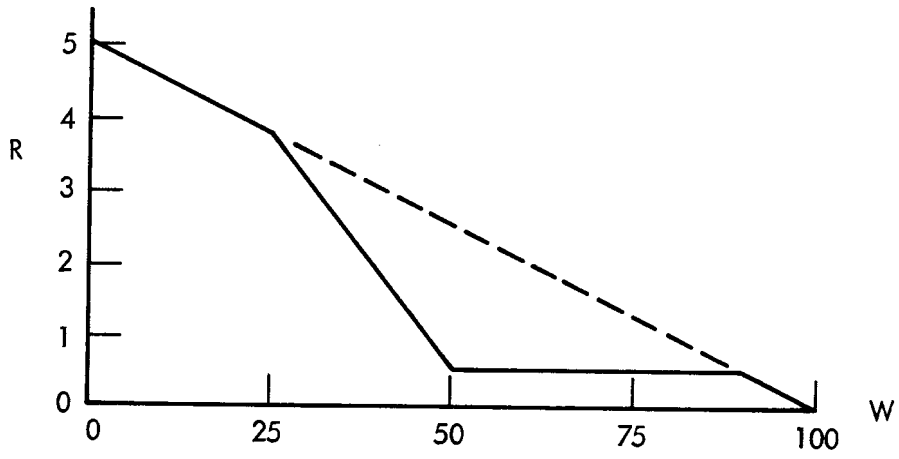

Fig. 25

and one consisting of a single color, or two mixtures. Three stable equilibria can be one mixture plus two extremes, one extreme plus two mixtures, or actually even three mixtures, and so forth. The occurrence of several mixed-color stable equilibria is usually sensitive, though, to small changes in the shapes and positions of the curves. It is the extreme one-color stable equilibria that tend to be least disturbed by shifts in the tolerance schedules or changes in the aggregate numbers; and the occurrence of a single mixed stable equilibrium may be fairly immune to shifts in the curves.

Figures 26 and 27 illustrate a few interesting possibilities. In Figure 26 the whites divide into three parts--those that have unlimited tolerance, those that have (the same) limited tolerance, and those that have no tolerance for the presence of blacks. If blacks are equal in number and similarly divided the solid curve for blacks is obtained; there are three stable equilibria, each containing the whites and blacks of unlimited tolerance, one containing them only, and the others containing as well the whites of limited tolerance or, alternatively, the blacks. If blacks are half the number of whites, the dotted line replaces the solid line and there is the single equilibrium. If instead the blacks' curve is the parabola of Figure 20, it may intersect the vertical part of the whites' curve to produce a stable mixture, together with another stable all-white equilibrium.

Figure 27 illustrates two extreme cases. One tolerance schedule is a rectangular hyperbola,  $RN = .9$ , where  $R$  is the opposite-own color ratio and  $N$  the number, for both blacks and whites in equal numbers. The other is the horizontal line,  $R = 1.1$ , all whites having the same tolerance. The latter lies almost entirely within the former and appears much less "tolerant" in the aggregate,

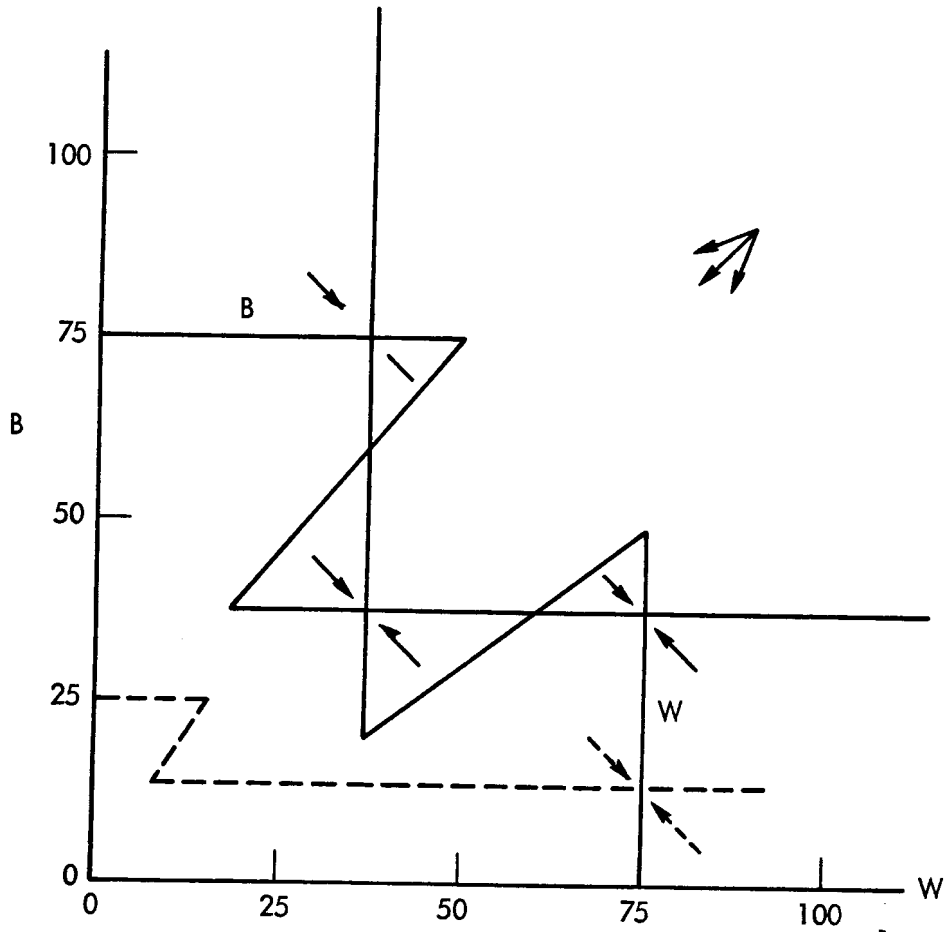
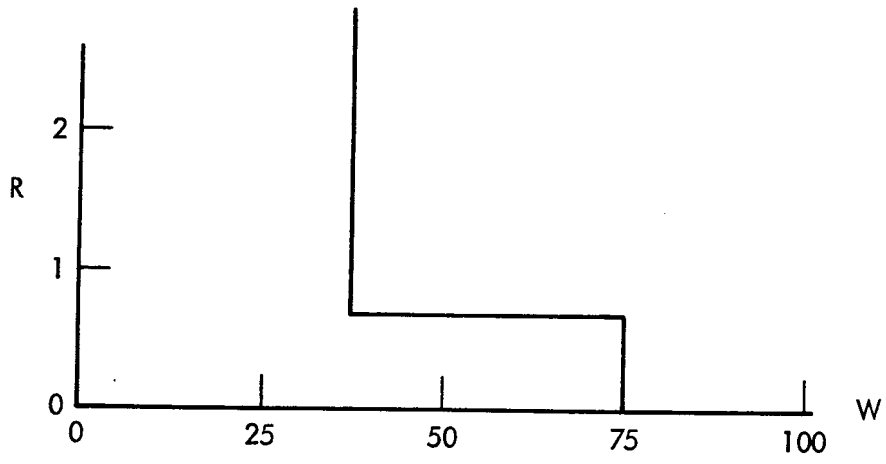

Fig. 26

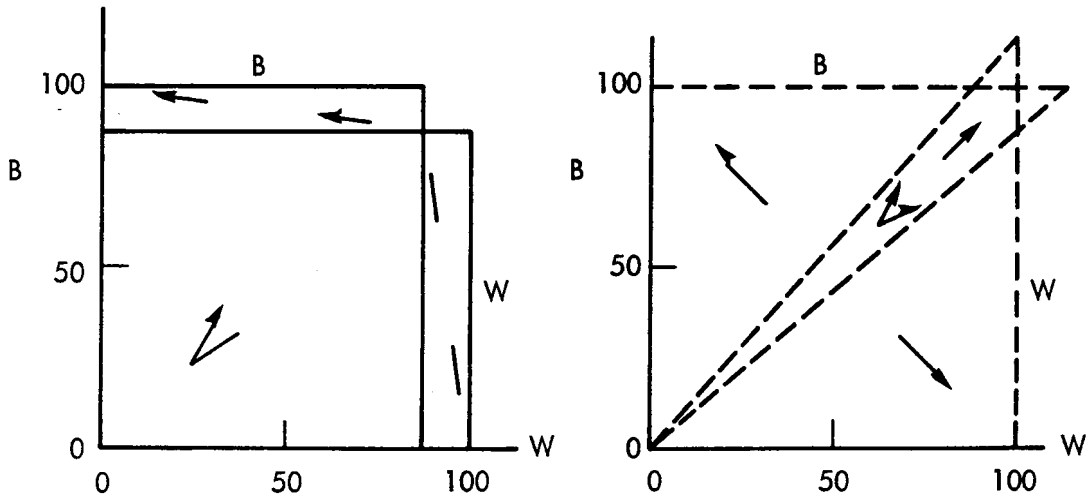
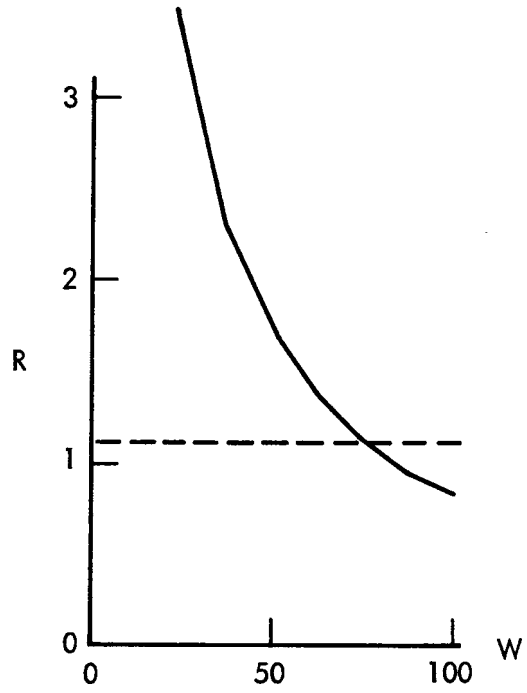

Fig. 27

but provides a precarious stable equilibrium with all blacks and all whites present--precarious because it is stable only against small perturbations. Evidently a great variety of shapes can be fitted beneath the rectangular hyperbola, being "dominated" by it as far as tolerance is concerned--i.e., being unambiguously less tolerant throughout--yet capable of producing one or more stable mixtures. The rectangular hyperbola for whites is compatible with the black schedule of Figure 20 (yielding the parabolic reaction curve) if black numbers are sufficient to make the curve protrude through the "ceiling" at 100 whites.

2. To make possible a stable mixed equilibrium it is sometimes sufficient to limit the number of one color that may be present; it is sometimes necessary to limit the number of both colors that may be present; and if the curves do not overlap at all there is no numbers limitation that will bring about a stable mixture.

3. Limiting the ratio of black to white or white to black that may be present, by restricting the further entry of the color that exceeds the limiting ratio, may or may not provide a stable equilibrium according to the shapes and positions of the two curves. Furthermore, limiting the ratio may exclude one or more stable equilibria and thus bring about the particular color combination corresponding to a particular stable equilibrium. Two possibilities are shown in Figures 28 and 29. The interpretation of the ratio limit, in both these figures, is that when the ratio of white to black is at or beyond its limit no more whites may enter (though blacks are free to leave, causing the ratio to increase further), and similarly for the limiting ratio of black to white. In Figure 28 no stable equilibrium is produced by the ratio limits; the stable equilibria are all-white and all-black but

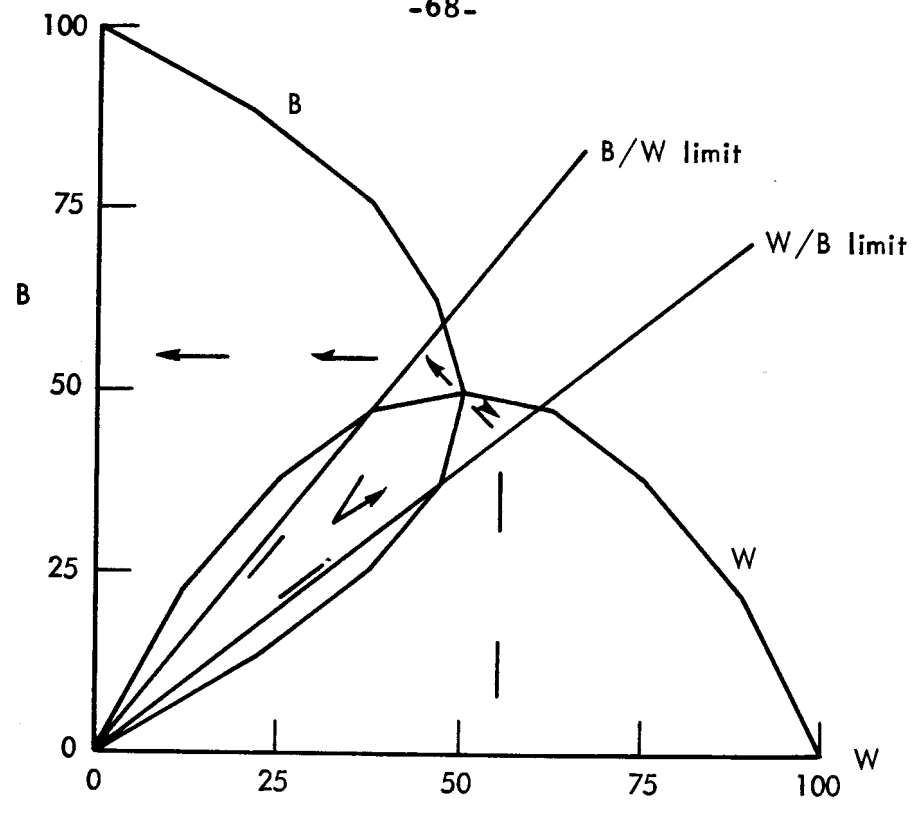

Fig. 28

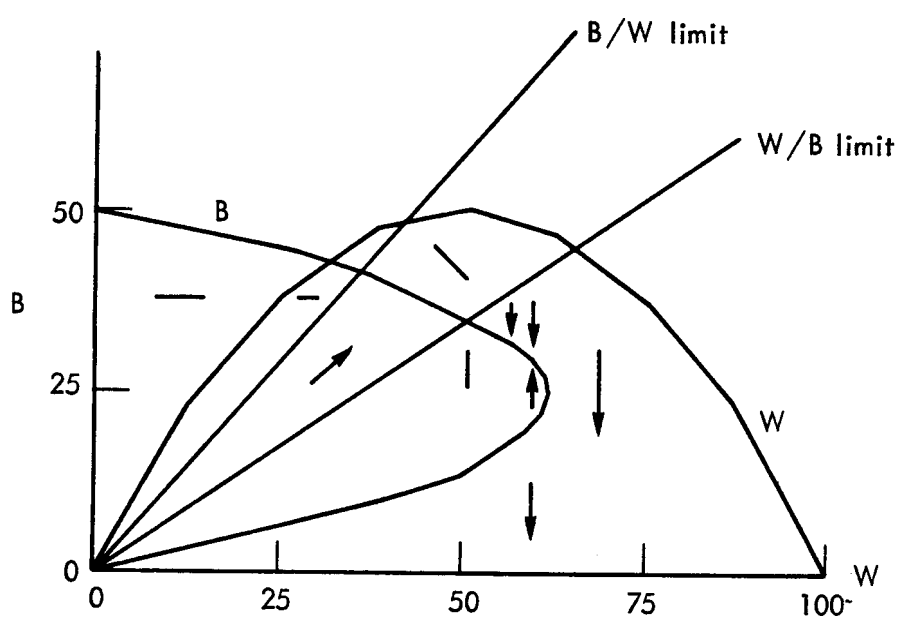

Fig. 29

without all the whites or all the blacks. In Figure 29 a stable equilibrium is produced at the white/black upper limit where it intersects the blacks' reaction curve.

4. A limitation on total occupancy can provide a neutral equilibrium that may be wide or narrow according to the shapes of the curves, as in Figure 24.

5. If the two colors have similar tolerance schedules for each other, the likelihood of a stable mixed equilibrium is greater, the more nearly equal are the numbers of the two colors. That is, the greater the disparity in total numbers of blacks and whites, the fewer are the tolerance schedules for the two colors that will lead to a stable equilibrium.

6. In general, for a stable mixture, the minority must be the more tolerant of the two groups. Either the mixed equilibrium will be one in which the majority group outnumbers the minority group, or else it will be one in which a larger percentage of the majority absents itself than of the minority. That is to say, if whites outnumber blacks in the aggregate by five to one, a mixed population in the local area requires either that blacks be outnumbered by whites or that four-fifths or more of the whites be incapable of abiding equal numbers of the two colors.

7. If there are only two locations altogether, one of which is preferred by both colors, the alternative to mixed living in the preferred location is not that members of both colors can go elsewhere and live by themselves. The alternative location is bound to be occupied by one of the two colors only, since any difference in the ratios in the two places would make the color with the most adverse ratio in the alternative location doubly motivated to move into the preferred area; and at equal ratios both colors would prefer to move. It turns out that

restricting the alternatives to a single area, where not both colors can live segregated, can have the effect (1) of providing a mixed equilibrium in the preferred area, or the effect (2) of destroying a mixed equilibrium in the preferred area. Plausible shapes of the curves are compatible with either result.

Superimposing on Figure 20, for example, the restriction of a single alternative location occupied by all those blacks and whites that do not live in the preferred location, we obtain a mixed stable equilibrium consisting of all the blacks and some of the whites in the preferred area (as well as two stable segregated equilibria). Superimposing the same restriction on Figure 19, however, spoils the possibility of a stable mixture and only the two segregated extremes are dynamically stable.

If both blacks and whites are divided in their preferences for the two areas, some of both colors preferring one area, some the other, there may be stable mixtures in both areas, a stable mixture in one with part of one color exclusively in the other, or stable segregated occupancy of the two areas, depending on the shapes of the curves and the initial conditions.

#### INTEGRATIONIST PREFERENCES

Somewhat surprisingly, the results generated by this analysis do not depend upon each color's having a preference for living separately. They do not even depend on a preference for being the majority! For simplicity of exposition it has been supposed that each individual is limited in his "tolerance" for the other color and will go elsewhere, to live among his own color, if the ratio in his preferred place becomes too extreme. One can equally well postulate, though, that most blacks and most whites



prefer a color mixture. One can then reinterpret the same schedules of tolerance to denote merely the upper limits to the ratios at which people's preference for integrated residence is outweighed by their extreme minority status (or by their inadequately majority status). The same model fits both interpretations! The results one gets with the original model are pertinent to the study of preferences for integration as well as to the study of preferences for separation.

#### POLICIES AND INSTRUMENTS

The analysis is pertinent to the study of the way that numerical quotas or ratio quotas or limits on total numbers may affect the likelihood of a mixed stable equilibrium. It is equally pertinent to the study of the role of concerted action. The occurrence of an intersection of the two curves could constitute a stable equilibrium but does not usually guarantee that that equilibrium will result; it usually competes with extreme mono-colored stable equilibria. When there are two or more potential stable equilibria, initial conditions and rates of movement determine which one will result.

Getting "over the hump" from one stable equilibrium to another often requires either a large perturbation or concerted action. Acting in concert, people can achieve an alternative stable equilibrium. (Blacks and whites cannot both successfully concert in opposition to each other; either color, by concerted action, may overwhelm the other, but not both simultaneously.)

The model as described is limited in the phenomena it can handle because it makes no allowance for speculative behavior, for time lags in behavior, for organized action, or for misperception. It also involves a single area rather than many areas simultaneously affected, each of

which is one of the "alternatives" that we have in mind when we study another. The model can, however, be enlarged to accommodate some of these enrichments.

#### IV. NEIGHBORHOOD TIPPING

The foregoing analysis can be used to explore the phenomenon of "neighborhood tipping." "Tipping" is said to occur when a recognizable new minority enters a neighborhood in sufficient numbers to cause the earlier residents to begin evacuating. The phenomenon has been discussed by Morton Grodzins, who says that "for the vast majority of white Americans a tipping point exists," and cites 20 percent Negroes as a commonly estimated upper limit in some Eastern cities.\* He states as an empirical generalization that, once an urban area begins to swing from mainly white to mainly Negro, the change is rarely reversed. (This could mean either that tipping is nearly universal and irreversible, or alternatively that tipping, when it occurs, accelerates a process that is inevitable and irreversible anyway.) A study of Chicago found no instance between 1940 and 1950 of a mixed neighborhood (25 to 75 percent white) in which succession from white to Negro occupancy was arrested or reversed.\*\*

The "tipping phenomenon" was observed closely by A. J. Mayer in a well-defined neighborhood of about 700 single-family homes, surrounded by racially mixed neighborhoods.\*\*\* A few houses were sold to Negroes in 1955. "The selling of the third house convinced everyone that the neighborhood was destined to become mixed." A year later 40 houses had been sold to Negroes; everyone defined

---

\*Metropolitan Segregation (pamphlet), University of Chicago Press, 1957, also his article of the same title in Scientific American, October 1957.

\*\*Otis Dudley Duncan and Beverly Duncan, The Negro Population of Chicago, University of Chicago Press, 1957, Chapter 6. The Duncans found succession rarely reversed once it reached 10 percent Negro (p. 11).

\*\*\*See his chapter, "Russell Woods: Change Without Conflict," in Nathan Glazer (ed.), Studies in Housing and Minority Groups, Berkeley, 1960.

the neighborhood as "mixed"; and opinion varied on whether the neighborhood would become completely Negro. In another two years the percentage had gone above 50 percent, and the end result was no longer questioned.

The same or a similar phenomenon has occasionally been observed for ethnic groups other than Negroes, also for clubs, schools, occupations, and apartment buildings, sometimes with males and females rather than ethnic groups, and sometimes with age groups. (An ice-cream parlor in Lexington, Massachusetts, "tipped" to a teenage clientele; lady shoppers and mothers of small children ceased coming, and it closed.)

Some crucial characteristics of any model of this alleged phenomenon are whether the neighborhood has a fixed and well-recognized boundary, whether the new entrants (the "minority") are clearly recognizable as a separate group, what the normal rate of turnover is, how many potential entrants there are compared with the size of the neighborhood and at what rate their number increases, what alternative neighborhoods are available for those who evacuate and what alternatives there are for the "minority" that seeks entrance.

This is evidently the kind of process our analysis has been dealing with. Specifically, this is a phenomenon that is alleged to occur in a well-defined neighborhood when something disturbs the original equilibrium at 100 percent white.

Assuming that this is a neighborhood of houses, rather than a blank space available for settlement, there is a rather inflexible capacity limit on the combined total of both colors that can be accommodated. Entry is limited either by the normal turnover of housing or by the rate at which the initial residents can evacuate. There

is a primary role of the white population (or initial population, whatever its defining characteristic) that already resides in the area, but an important additional interest in the potential new white entrants who would represent the inflow under normal turnover in the absence of any tipping phenomenon. If the process takes time, the potential population would keep changing in composition, as today's home-hunters settle elsewhere and new ones arise in the general area. We can sometimes assume that whites already resident have somewhat more tolerance than outsiders, relative to their preference for living in this area, simply because it takes a stronger inducement to make a family move out than to make a family merely decide not to move in.

The black population may be small or large relative to the neighborhood. Or it could be small in the short run but cumulatively large with the passage of time.

A number of possibilities are illustrated in Figures 30, 31, and 32. In few if any of these figures is it clear just what we might want to call the "tipping point." There are several points at which something discontinuous happens or some cumulative process begins. Furthermore, it is interesting that in none of the cases shown does any important discontinuity necessarily occur at the modal or typical tolerance value. If "most Americans can tolerate about 20 percent blacks in their community," any tipping point or tipping points tend to occur at quite different percentage figures!

Among the figures shown, an important difference is between those in which the blacks have an "in-tipping" point and those in which they do not. When the black reaction curve encloses the lower right-hand point of all-white occupancy, there are blacks ready to move in as rapidly as houses become available; when it does not enclose that

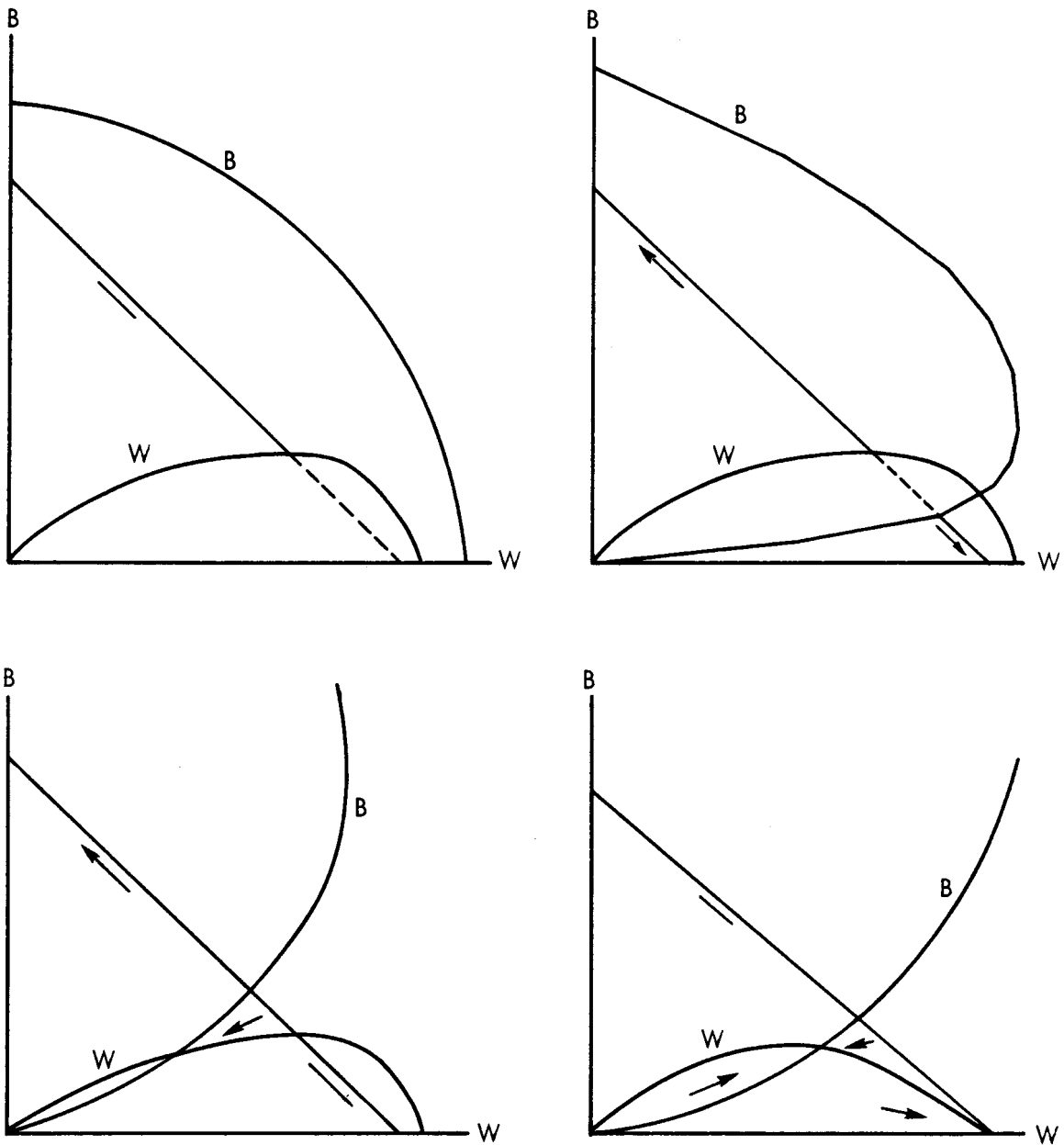

Fig. 30

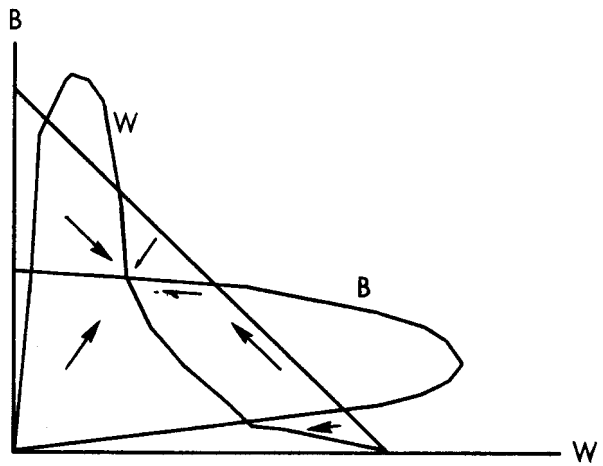
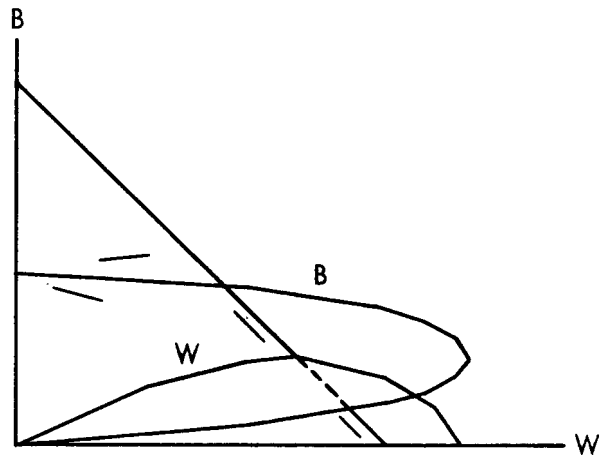
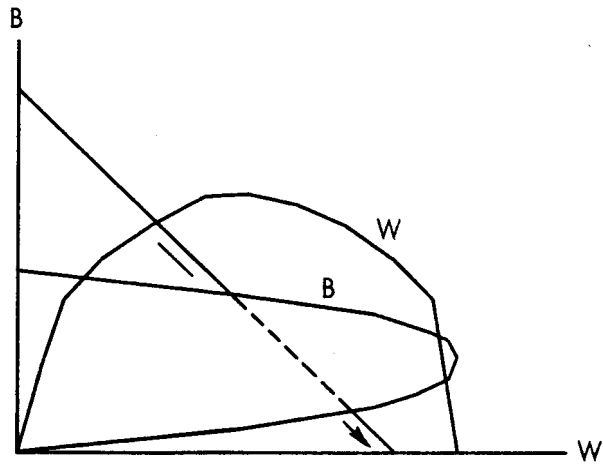

Fig. 31

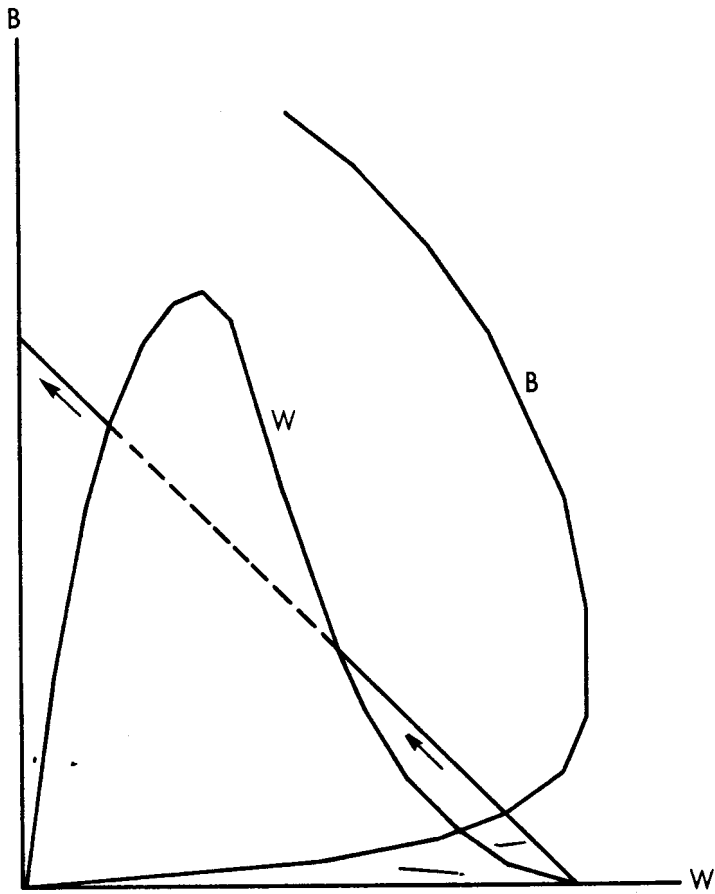

Fig. 32



point, there is a stable equilibrium that has to be overcome by some event or process. That process could be concerted entry, erroneous entry by a few, organized introduction of a few, redefinition of the neighborhood boundary so that some who were not inside become "inside," or something of the sort.

A possibility is that the number of blacks willing to live as a tiny minority in this white neighborhood is not zero but is too small to attract other blacks, but nevertheless reaches a large cumulative total over time, so that a slow process of black entry may gradually bring the black-white ratio up to where more blacks are attracted and, by entering, attract still more, and so on in the cumulative process analyzed earlier. At the point where the black reaction curve cuts the 45-degree line denoting the capacity of the neighborhood, we might say that "tipping-in" has begun. This is the point at which blacks will surge in, if houses are available, rather than merely show up from time to time.

Another important difference is between the case in which there are enough blacks to fill the neighborhood and the case in which there are not. One possibility is that there are enough blacks seeking entry to cause the whites to evacuate but not enough to fill the neighborhood, so that the neighborhood becomes all-black and partly vacant. Another possibility is that there are not enough blacks to cause all the whites to evacuate, but the whites who remain in the mixed population are too few in number, together with the blacks, to fill the area, so that a mixed equilibrium occurs with excess capacity. (As the price of housing falls in the face of excess capacity, more blacks may be attracted, but possibly more whites will also.)

An important possibility is shown in Figure 32. Here the presence of a few Negroes will cause whites to evacu-

ate in appreciable numbers but, because the white tolerance schedule becomes inelastic, the white reaction curve becomes steep and cuts the 45-degree line, so that white evacuation ceases and more blacks can move in only as vacancies occur from normal turnover. (If or when the population mix reaches the point where the reaction curve again cuts the 45-degree line, the cumulative process of white evacuation begins again.)

An important possibility is that blacks define sub-neighborhoods while whites define the larger neighborhood; if blacks are willing to be 30 percent of a sub-neighborhood of 50 houses, they may "tip in" after the number of black homes reaches 15, even though in the larger neighborhood of 1,000 houses they are only  $1\frac{1}{2}$  percent. An alternative phenomenon is that whites evacuate the sub-neighborhood because they count the black density locally, on an adjacency basis; in that case we have something like our checkerboard analysis to consult. Evidently the process is limited only by evacuation speeds if no one in the majority can abide a next neighbor from the minority or any significant number across the street or around the corner. The "proximity model" of Section II may apply in the small, and the "bounded area model" of Section III in the large, as next neighbors react to immediate proximity while more distant ones react to neighborhood proportions.

Speculation has been adduced as an aggravating factor. Whites may respond not to the number or percentage of blacks currently present, but to the anticipated increase in the number. They may, that is, anticipate the process.\* Evidently if whites believe that the percentage

---

\*In the Russell Woods example, mentioned earlier, the residents certainly expected large numbers of Negroes on the basis of the first three or so, and at 40 percent Negro nearly everybody took an ultimate 100 percent for granted. Just knowing that he is bound to move in a year

of blacks will become intolerable and are prepared to leave in anticipation once they believe it, the number of blacks required to cause "out-tipping" is not the number that begins a cumulative process in our analysis but rather the number that induces this belief. There will still be a cumulative process: those whites who evacuate in anticipation may enhance the belief of other whites in the inevitability of the process.

Speculative departure, though, requires that there be some penalty on late departure or some premium on early departure. Anticipated financial loss or anticipated delay in departure could cause people to leave early; otherwise people could wait and see. Such things as lease and ownership arrangements would be relevant here.

The partitioning of territory into well-defined neighborhoods may contribute to a "channeling" process. It may lead blacks to concentrate on one area rather than several; it may lead whites to believe that the blacks will concentrate on one area rather than several. It may lead to experience that tends to confirm the tipping hypothesis, so that if speculative departure is relevant, the beliefs conducive to departure will be reinforced. And it can lead to a concentration of real-estate sales activity on a "target neighborhood." If lending and sales agencies have been reluctant to sell houses or lend on them to Negroes in all-white neighborhoods, the inhibitions may dissolve upon entry of a few Negroes into a particular neighborhood, causing a differential ease of entry and serving as a further signal that Negro demand, blocked elsewhere, will concentrate on this neighborhood. Thus "neighborhood tipping," in contrast to the domino effect

or two may make a person move at the first convenient opportunity; otherwise only risk of financial loss, or of being "locked in" beyond one's own "static tipping point," would cause speculative evacuation.

of very local proximity avoidance, depends on comparatively small and well-defined neighborhoods.

An interesting and important question is whether an entire metropolitan area might "tip." There is also the question whether some major non-residential unit, say the United States Army, could tip. City school systems evidently lend themselves to the phenomenon.

The process is too complex to be treated comprehensively in this memorandum, but evidently the phenomenon involved requires the kind of analysis that this memorandum attempts to develop.