



U.S. DEPARTMENT OF
ENERGY

PNNL-18035

Prepared for the U.S. Department of Energy
under Contract DE-AC05-76RL01830

Modern Grid Initiative

Distribution Taxonomy Final Report

KP Schneider
Y Chen
DP Chassin
RG Pratt

DW Engel
SE Thompson

November 2008



Pacific Northwest
NATIONAL LABORATORY

*Proudly Operated by **Battelle** Since 1965*

DISCLAIMER

This report was prepared as an account of work sponsored by an agency of the United States Government. Neither the United States Government nor any agency thereof, nor Battelle Memorial Institute, nor any of their employees, makes **any warranty, express or implied, or assumes any legal liability or responsibility for the accuracy, completeness, or usefulness of any information, apparatus, product, or process disclosed, or represents that its use would not infringe privately owned rights.** Reference herein to any specific commercial product, process, or service by trade name, trademark, manufacturer, or otherwise does not necessarily constitute or imply its endorsement, recommendation, or favoring by the United States Government or any agency thereof, or Battelle Memorial Institute. The views and opinions of authors expressed herein do not necessarily state or reflect those of the United States Government or any agency thereof.

PACIFIC NORTHWEST NATIONAL LABORATORY

operated by

BATTELLE

for the

UNITED STATES DEPARTMENT OF ENERGY

under Contract DE-AC05-76RL01830

Printed in the United States of America

Available to DOE and DOE contractors from the
Office of Scientific and Technical Information,
P.O. Box 62, Oak Ridge, TN 37831-0062;
ph: (865) 576-8401
fax: (865) 576-5728
email: reports@adonis.osti.gov

Available to the public from the National Technical Information Service,
U.S. Department of Commerce, 5285 Port Royal Rd., Springfield, VA 22161
ph: (800) 553-6847
fax: (703) 605-6900
email: orders@ntis.fedworld.gov
online ordering: <http://www.ntis.gov/ordering.htm>



This document was printed on recycled paper.

(9/2003)

Modern Grid Initiative

Distribution Taxonomy Final Report

KP Schneider
Y Chen
DP Chassin
RG Pratt

DW Engel
SE Thompson

November 2008

Prepared for the U.S. Department of Energy
under Contract DE-AC05-76RL01830

Pacific Northwest National Laboratory
Richland, Washington 99352

Table of Contents

1.	INTRODUCTION	1
2.	BASIS FOR FEEDER SELECTION	1
2.1	CHARACTERIZATION OF COLLECTED DISTRIBUTION FEEDERS	2
2.1.1	<i>Collection</i>	2
2.1.2	<i>Characterization</i>	4
2.1.2.1	Degree.....	6
2.1.2.2	Diameter	7
2.1.2.3	Closeness.....	7
2.1.2.4	Centrality.....	7
2.2	STATISTICAL ANALYSIS	7
2.2.1	<i>Clustering Algorithms</i>	8
2.2.2	<i>Cluster Variables</i>	9
2.2.3	<i>Cluster Analysis</i>	11
3.	TAXONOMY FEEDERS	18
4.	WEIGHTING FACTORS	18
5.	CONCLUDING REMARKS	21
6.	APPENDIX I: TAXONOMY OF FEEDERS	21
6.1	CLIMATE REGION 1	21
6.1.1	<i>Feeder 1: R1-12.47-1</i>	21
6.1.2	<i>Feeder 2: R1-12.47-2</i>	22
6.1.3	<i>Feeder 3: R1-12.47-3</i>	22
6.1.4	<i>Feeder 4: R1-12.47-4</i>	23
6.1.5	<i>Feeder 5: R1-25.00-1</i>	23
6.2	CLIMATE REGION 2	24
6.2.1	<i>Feeder 6: R2-12.47-1</i>	24
6.2.2	<i>Feeder 7: R2-12.47-2</i>	24
6.2.3	<i>Feeder 8: R2-12.47-3</i>	25
6.2.4	<i>Feeder 9: R2-25.00-1</i>	25
6.2.5	<i>Feeder 10: R2-35.00-1</i>	26
6.3	CLIMATE REGION 3	26
6.3.1	<i>Feeder 11: R3-12.47-1</i>	26
6.3.2	<i>Feeder 12: R3-12.47-2</i>	27
6.3.3	<i>Feeder 13: R3-12.47-3</i>	27
6.4	CLIMATE REGION 4	28
6.4.1	<i>Feeder 14: R4-12.47-1</i>	28
6.4.2	<i>Feeder 15: R4-12.47-2</i>	28
6.4.3	<i>Feeder 16: R4-25.00-1</i>	29
6.5	CLIMATE REGION 5	29

6.5.1	<i>Feeder 17: R5-12.47-1</i>	30
6.5.2	<i>Feeder 18: R5-12.47-2</i>	30
6.5.3	<i>Feeder 19: R5-12.47-3</i>	31
6.5.4	<i>Feeder 20: R5-12.47-4</i>	31
6.5.5	<i>Feeder 21: R5-12.47-5</i>	32
6.5.6	<i>Feeder 22: R5-25.00-1</i>	32
6.5.7	<i>Feeder 23: R5-35.00-1</i>	33
6.6	GENERAL FEEDERS	33
	<i>Feeder 24: GC-12.47-1</i>	33
6.7	FEEDER SUMMARY	34
7.	REFERENCES	35

1. Introduction

Two of the primary goals of the Department of Energy's (DOE) Modern Grid Initiative (MGI) are "to accelerate the modernization of our nation's electricity grid" and to "support demonstrations of systems of key technologies that can serve as the foundation for an integrated, modern power grid". A key component to the realization of these goals is the effective implementation of new, as well as existing, "smart grid technologies". Possibly the largest barrier that has been identified in the deployment of smart grid technologies is the inability to evaluate how their deployment will affect the electricity infrastructure, both locally and on a regional scale. The inability to evaluate the impacts of these technologies is primarily due to the lack of detailed electrical distribution feeder information. While detailed distribution feeder information does reside with the various distribution utilities, there is no central repository of information that can be openly accessed.

The role of Pacific Northwest National Laboratory (PNNL) in the MGI for FY08 was to collect distribution feeder models, in the SynerGEE® format, from electric utilities around the nation so that they could be analyzed to identify regional differences in feeder design and operation. Based on this analysis PNNL developed a taxonomy of 24 prototypical feeder models in the GridLAB-D simulations environment that contain the fundamental characteristics of non-urban core, radial distribution feeders from the various regions of the U.S. Weighting factors for these feeders are also presented so that they can be used to generate a representative sample for various regions within the United States. The final product presented in this report is a toolset that enables the evaluation of new smart grid technologies, with the ability to aggregate their effects to regional and national levels. The distribution feeder models presented in this report are based on actual utility models but do not contain any proprietary or system specific information. As a result, the models discussed in this report can be openly distributed to industry, academia, or any interested entity, in order to facilitate the ability to evaluate smart grid technologies.

2. Basis for Feeder Selection

In order to effectively analyze the impact of a new technology it is necessary to study its behavior in the environment in which it will be deployed. For smart grid technologies deployed on electric distribution systems this means being able to effectively model the primary and secondary systems. The challenge to this approach is that in the United States alone there are tens of thousands of distribution substations and hundreds of thousands of distribution feeders. These systems have evolved over the past 100 years in a wide variety of environments, and not just in regards to climate. While climate has a significant impact on how distribution feeders have been designed, there are also other factors such as regulatory and business environments which have shaped their development. In addition to this many systems have been operated based on decisions and assumptions that were made decades ago by personnel who no longer work for the utility.

Because of the many factors that determine the structure of distribution feeders it is not possible to simply state that there is a single effective model for all 12.47 kV residential feeders in the United States. While there may not be a single feeder that properly displays the characteristics of every 12.47 kV residential feeder in the nation, it is possible to develop a set of feeders that displays the major characteristics of this type of feeder. And this is what the work in this report has attempted to do. The feeders that are presented are each representative of a class of feeders that can be found in each of the 5 major climate regions of the 48 contiguous states. While the 24 feeders presented do not capture every nuance of distribution feeder design, they form an initial body of work that researchers can use to begin the task of understanding distribution feeders and how smart grid technologies behave when connected to a radial distribution feeder. These feeders represent the first collection of models that is openly available and presented in the level of detail that is necessary to evaluate the effects of smart grid technologies. As such it is a critical first step in enabling these new technologies.

2.1 Characterization of Collected Distribution Feeders

In order to determine the characteristics of distribution feeders a number of distribution utilities were contacted and their system models were obtained. These models were then analyzed and fundamental characteristics were determined. From these characteristics the feeders were classified and clustered accordingly. These clusters were then used to construct a set of prototypical distribution feeder models. The following two sections describe the collection process, including what information was collected, and the fundamental characteristic which were identified for clustering.

2.1.1 Collection

Ideally the taxonomy of prototypical feeders presented in this report would be based on an analysis of every distribution feeder in the United States; which is impractical. Not only are there too many utilities to contact, but they use a variety of simulation packages to model their systems. Because the models were to be analyzed in GridLAB-D it was necessary to write scripts to convert the system models from a commercial simulation package into the GridLAB-D file format. Because of the complexity of writing effective conversion routines it was determined that only systems that were modeled in the SynerGEE® software package would be used. This decision limited the utilities which could participate in this project but it allowed more time to be spent analyzing data and less time writing conversion programs, which is a significant task.

In total 575 distribution feeder models from 151 separate substations were collected from utilities across the nation. These feeders were collected from Investor Owned Utilities (IOUs), Public Utility Districts (PUDs), Municipalities (MUNs), as well as members of the Rural Electrification Association (REAs). These utilities range in size from small local utilities to utilities that cover multiple states. In total 17 different utilities supplied models of a portion of their systems to the MGI for this taxonomy work. Table 1 shows the number of distribution feeder models that were supplied by each of the utilities, as well as what type of utility they were.

Table 1: Number of feeders by utility and utility type

Utility Type	IOU	REA	PUD	MUN
Utility 1	0	0	73	0
Utility 2	0	0	0	14
Utility 3	18	0	0	0
Utility 4	54	0	0	0
Utility 5	21	0	0	0
Utility 6	0	0	41	0
Utility 7	0	0	0	61
Utility 8	9	0	0	0
Utility 9	0	37	0	0
Utility 10	0	0	17	0
Utility 11	0	0	0	41
Utility 12	32	0	0	0
Utility 13	0	0	106	0
Utility 14	0	0	0	16
Utility 15	0	0	8	0
Utility 16	10	0	0	0
Utility 17	17	0	0	0
Sub-Totals	161	37	245	132

In total 6 IOUs, 1 REA, 5 PUDs, and 4 MUN participated in the development of the feeder taxonomy. The participation of additional utilities was limited because of time requirements as well as the requirements of processing the additional data. For the feeders that were collected a significant amount of processing was required to ensure that the information that we were collecting was consistent across the entire data set. Even though all of the models that were collected were in the SynerGEE® database format, there was a wide variety with regard to the data quality. The issue of data quality and data consistency was one of the largest issues that had to be addressed.

While Table 1 shows the various types of utilities that participated in the taxonomy development and the numbers of feeders that they contributed, Figure 1 shows the various voltage levels of the distribution feeders that were contributed. From Figure 1 it is clear that 12.47 kV is the most common voltage level that was observed. While some feeders were represented as having 12.5 kV as their nominal voltage, they used 12.47 kV class equipment. Just as data quality within a utility was an issue inconsistencies that were experienced from utility to utility had to be addressed.

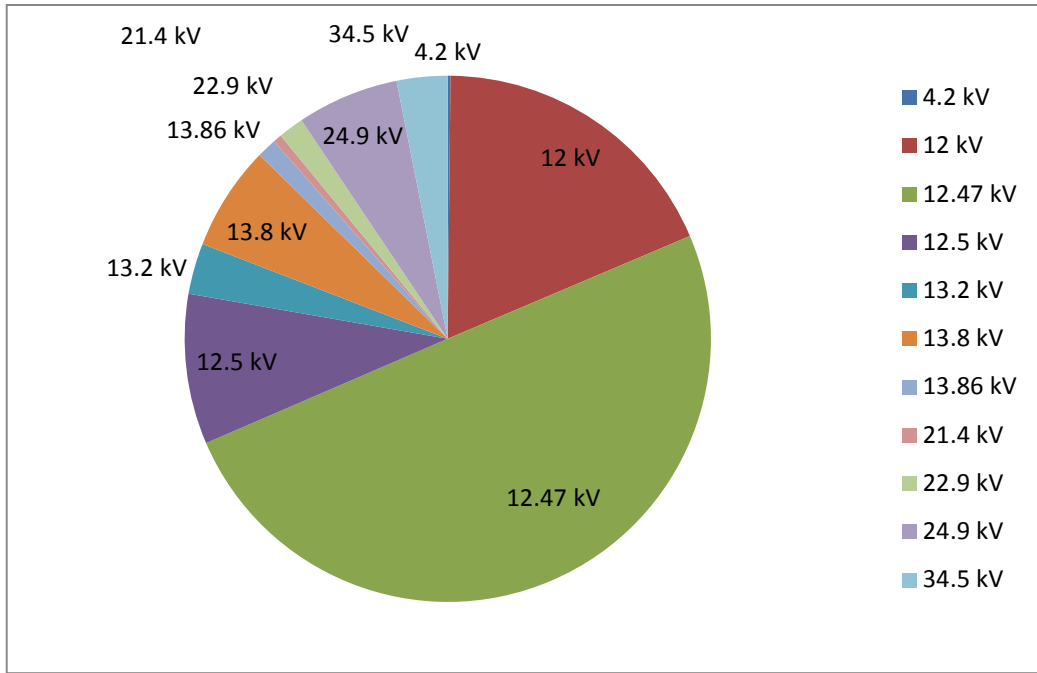

Figure 1: Breakdown of feeder voltage levels

2.1.2 Characterization

Distribution feeders have hundreds of characteristics that can be used to describe them. If each of these characteristics, and all their variations, were used to describe the feeders the result would be a set of representative feeders that was as large as the number of distribution feeders in the nation. For this reason characteristics were selected based on their significance to power system operations and the number of variations was limited. For example, voltage levels of 12.00 kV, 12.47 kV, 12.5 kV and 13.8 kV can be combined into a single characteristic of 12.47 kV. So instead of a representative feeder at each voltage level, there is only a single feeder at 12.47 kV. While there is a limited loss of detail, the set of representative feeders decreases by a factor of 4. Extensive use of these types of reductions was made in order to develop a representative set of feeders with only 24 members.

Once the distribution feeders were collected from the various utilities it was necessary to determine a methodology for classifying them. The 2 single largest defining factors for a distribution feeder are the voltage level, and the climate in which it is located. Classification by voltage level is relatively straight forward. Classification by climate region can be significantly more complicated, in particular the determination of the climate regions. For the analysis in this report regionalization was based on the U.S DOE handbook (1980) providing design guidance for energy-efficient small office buildings [1]. The number of feeders collected is shown on a map of the United States with the climate regions overlaid, shown in Figure 2.

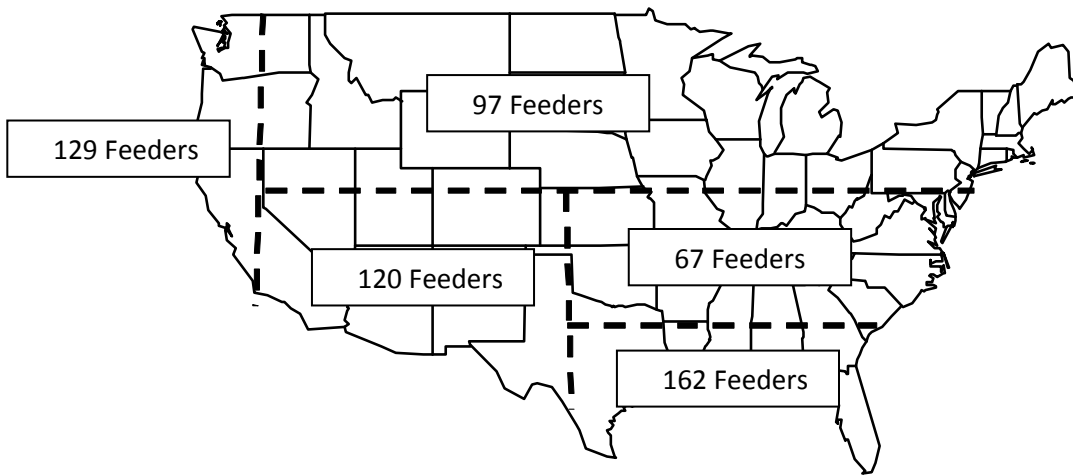

Figure 2: Feeder locations and climate regions of the United States

A map indicating the detailed boundaries of the 5 major climate regions, along with their defining characteristics can be seen in Figure 3 [2]. The characteristics of these climate regions have a significant impact on the heating and cooling requirements of residential and commercial loads. While it is possible to make further subdivisions within these climate regions the number of representative feeders that would be required would rapidly increase.

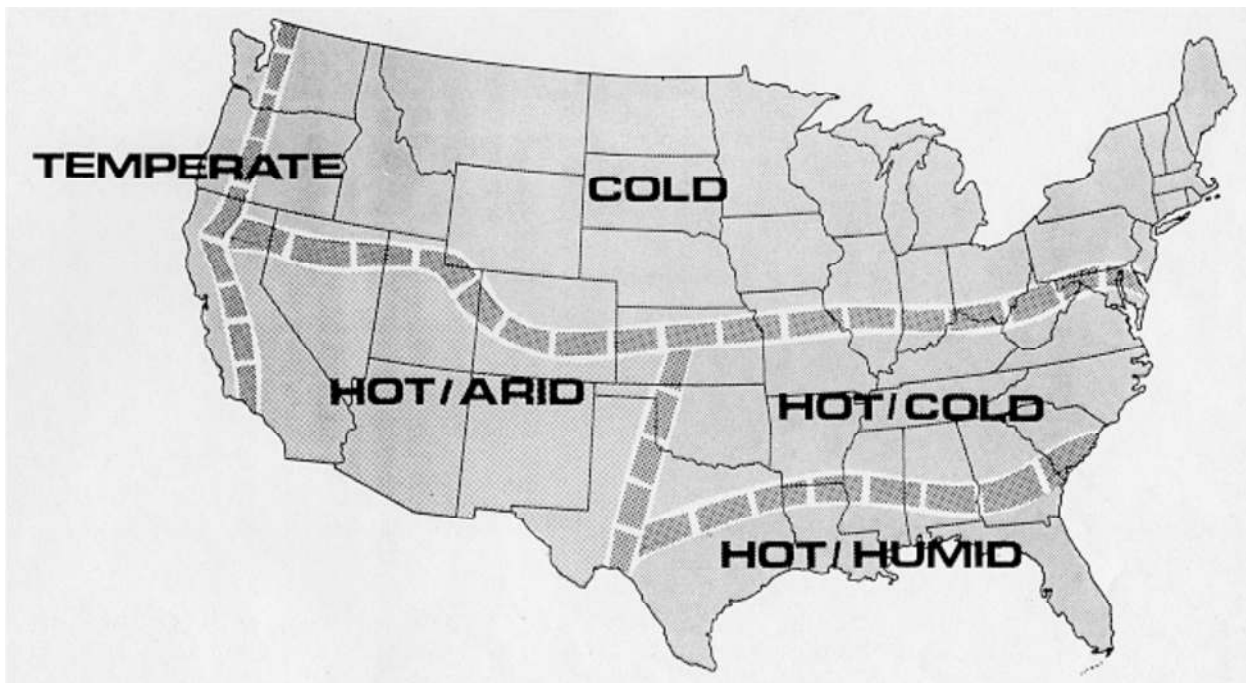

Figure 3: Climate zone characteristics

Due to the variety of feeder designs that were encountered, traditional metrics such as nominal voltage level, climate, and load composition were not sufficient to completely characterize the feeders. To address this issue extensive use of graph theory was made in order to quantify complex design decisions, such as the conductor of the feeder. Table 2 indicates all of the characteristics, in addition to voltage level and climate region, that were used to classify the 575 distribution feeders.

Table 2: Feeder properties

1. Mean overhead circuit length	13. Standard deviation of circuit rating	25. Geographic centrality
2. Standard deviation of overhead circuit length	14. Mean connected KVA (residential)	26. Electrical impedance diameter
3. Mean underground circuit length	15. Standard deviation of Mean connected KVA (residential)	27. Electrical impedance closeness
4. Standard deviation of underground circuit length	16. Mean connected KVA (commercial)	28. Electrical impedance centrality
5. Mean connected KVA (overhead)	17. Standard deviation of Mean connected KVA (commercial)	29. Electrical capacity diameter
6. Standard deviation of connected KVA (overhead)	18. Mean connected KVA (industrial)	30. Electrical capacity closeness
7. Mean connected KVA (underground)	19. Standard deviation of Mean connected KVA (industrial)	31. Electrical capacity centrality
8. Standard deviation of connected KVA (underground)	20. Mean connected KVA (agricultural)	32. Mean metered current
9. Feeder rating (summer amps)	21. Standard deviation of Mean connected KVA (agricultural)	33. Standard deviation of metered current
10. Mean feeder rating KVA	22. Geographic degree	34. Mean KVAR
11. Standard deviation of feeder rating (summer amps)	23. Geographic diameter	35. Standard deviation of KVAR
12. Mean circuit rating	24. Geographic closeness	

From Table 2 it can be seen that the general process of classification was performed using mean values and associated standard deviations. This is how the natural load imbalance of distribution feeders was handled. By using values for mean and standard deviation instead of phase a, b, and c the number of characteristics was reduced and the available information was better suited for statistical clustering. Properties 1 through 21, as well as 32 through 35 are values that would be well understood by any distribution engineer. Characteristics 22 through 31 are values that based on topological characteristics of the feeder. The same topological concepts of degree, diameter, closeness, and centrality are applied to three different parameters; geographic values, impedance values, and capacity values. By applying these graph theory concepts to these three parameters a wide range of feeder characteristics can be captured with relatively few metrics.

2.1.2.1 Degree

The geographic degree is a count of how many vertices have x incident edges. The degree count is a distribution over $k=(1...?)$, which can then be characterized by a Pareto distribution of degree k . The parameter k may be estimated by

$$\langle k \rangle = \frac{N}{\sum_N x_i i} \quad (2.1)$$

2.1.2.2 Diameter

This is the maximum eccentricity over all N vertices. The eccentricity is the greatest distance between any two vertices.

2.1.2.3 Closeness

Closeness is the mean geodesic distance (i.e., shortest path) between a vertex v and all the other vertices reachable from it:

$$\frac{1}{n-1} \sum_{v \neq t} d(v, t) \quad (2.2)$$

where $d(v, t)$ is the geodesic distance from v to t .

2.1.2.4 Centrality

Centrality (or eigenvector centrality) is the measure of the importance of a node in a network. This can be computed using an adjacency matrix. Let x_i denote the score of the i_{th} node. Let A be the adjacency matrix of the network, such that $A_{ij} = 1$ if the i_{th} node is directly connected to the j_{th} node, and $A_{ij} = 0$ otherwise. (If flows are considered, these can be real numbers representing the flow between the nodes.)

For the i_{th} node, let the centrality score be proportional to the sum of the scores of all nodes which are connected to it, or

$$x_i = \frac{1}{\lambda} \sum_{j \in M(i)} x_j \quad (2.3)$$

where $M(i)$ is the set of the nodes that are connected to the i_{th} node, N is the total number of nodes and λ is a constant. Equivalently using the adjacency matrix

$$x_i = \frac{1}{\lambda} \sum_{j=1}^N A_{ij} x_j \quad (2.4)$$

This can be written

$$x = \frac{1}{\lambda} Ax \quad (2.5)$$

Equation 2.5 is the eigenvector equation. Because there are potentially many eigenvalues for which an eigenvector solution exists, we consider the additional requirement that all the entries in the eigenvector be positive implies that only the greatest eigenvalue is the desired centrality measure. The i_{th} component of this eigenvector then gives the centrality score of the i_{th} node in the network.

2.2 Statistical Analysis

Based on preliminary cluster analysis and the feeder data, it was decided that the feeders would be initially grouped by voltage and regions. The original data was distributed between voltage and regions as shown in Table 3. The single feeder with a 4.2 kV voltage was deleted from the analysis and several

of the voltage categories were combined, as shown in Table 4.

Table 3: Feeders by voltage per region

Region	Voltage (kV)						
	4.2	12.47	13.8	21.4	22.9	24.9	34.5
1	0	124	0	3	0	2	0
2	0	63	17	0	0	15	2
3	0	120	0	0	0	0	0
4	1	32	15	0	0	19	0
5	0	107	30	0	9	0	16

Table 4 was constructed by combining the 12.47 kV and 13.8 kV feeders into a single group of 12.47 kV class feeders. The 21.4 kV, 22.9 kV, and 24.9 kV feeders were combined into a single set of 25.00 kV feeders and the 34.5 kV feeders formed the 35.00 kV class feeders.

Table 4: Feeders by clustered voltage per region

Region	Voltage (kV)		
	12.47	25.00	35.00
1	124	5	0
2	80	15	2
3	120	0	0
4	47	19	0
5	137	9	16

The taxonomy clustering was done by using a data clustering algorithm on the characteristics of table 2 after the feeders had been initially grouped as shown in Table 4, as well as by climate region. Data clustering is the process of dividing data elements into classes or clusters so that items in the same class are as similar as possible, and items in different classes are as dissimilar as possible. The cluster variables and algorithms will be discussed in sections 2.2.1 and 2.2.2 respectively.

2.2.1 Clustering Algorithms

Data clustering algorithms typically are grouped into two categories: hierarchical or partitional. Hierarchical algorithms find successive clusters using previously established clusters, whereas partitional algorithms determine all clusters at once, using a predetermined number of clusters [3] and [4]. Hierarchical algorithms can be agglomerative or divisive. Agglomerative algorithms begin with each element (as defined by the feeder parameters) as a separate cluster and merge them into successively larger clusters. Divisive algorithms begin with the whole set and proceed to divide it into successively smaller clusters.

For this analysis, hierarchical clustering was chosen to identify/categorize the feeder models. In our analysis, each object/feeder is initially assigned to its own cluster and then the algorithm proceeds

iteratively, at each stage joining the two most similar clusters, continuing until there is just a single cluster. At each stage/step Euclidean distance between clusters are recomputed according to the particular clustering method being used. For this analysis, the Ward's minimum variance method was used to select members of each cluster. This method was selected based on preliminary clustering analyses.

A number of different clustering methods were examined for this analysis. Each method has advantages, based on the type of data and characteristics of the analysis. For instance, the Ward's minimum variance method aims at finding compact, spherical clusters. The complete linkage method finds similar clusters. The single linkage method, which is closely related to the minimal spanning tree, adopts a 'friends of friends' clustering strategy. Other methods can be regarded as aiming for clusters with characteristics somewhere between the single and complete link methods.

The traditional representation of the cluster hierarchy is a tree, called a dendrogram, with individual elements at one end and a single cluster containing every element at the other. Agglomerative algorithms begin at the top of the tree, whereas divisive algorithms begin at the bottom. Cutting the tree at a given height will give a clustering at a selected precision. An example of a dendrogram and the selection of a height to define the clusters (groups) from the initial feeder data is shown and discussed in section 2.2.3.

2.2.2 Cluster Variables

The initial data set consisted of 575 feeders with each feeder containing 89 parameters including identification parameters, construction characteristics and operational characteristics. This initial set of parameters was reduced to 35 variables first by grouping clusters into voltage and region classes (3 voltage classes and 5 regions, see Table 4 and Figure 3). Within each grouping the variable list was further reduced by statistically combining (mean and standard deviation) feeder characteristic parameters across the 3 phases. For instance, the Mean overhead circuit length variable, see Table 2, was constructed by averaging the overhead length parameter across the 3 phases for each feeder. Similarly, the Standard deviation of overhead circuit length variable was constructed by taking the standard deviation across the 3 phases; a, b, and c. The variables used for the cluster analysis are shown in Table 3 with actual values shown in the plots in Figure 4.

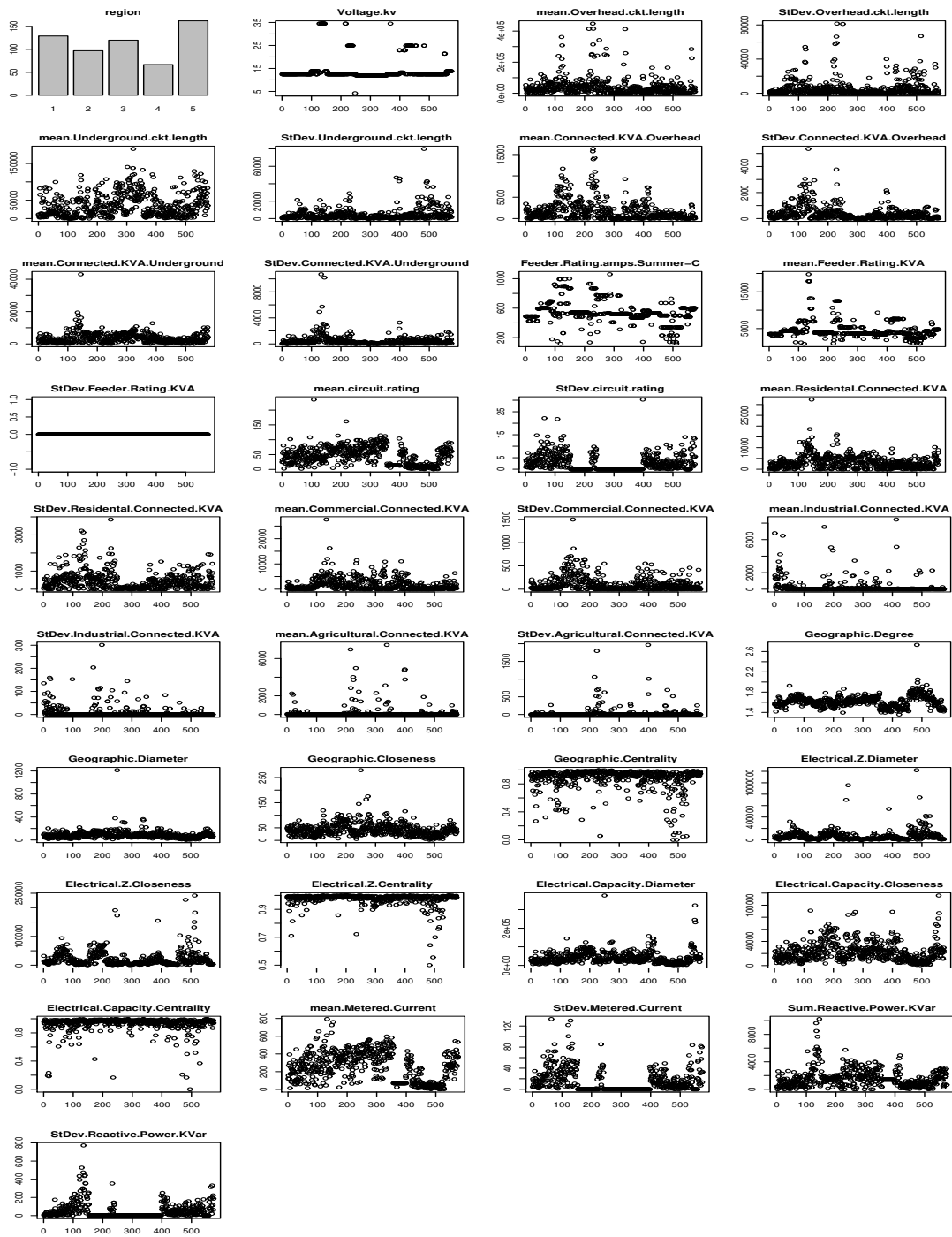

Figure 4: Actual values of feeder characteristics

Before clustering, the data was scaled using the Probability Integral Transformation (PIT) as shown in Equation 2.6.

$$x_{pit} = \frac{x - x_{min}}{x_{max} - x_{min}} \quad (2.6)$$

where X_{min} and X_{max} are the minimum and maximum for each variable. This transformation retains the original data structure while scaling all variables to the range of 0 to 1.

2.2.3 Cluster Analysis

As mentioned earlier, the overall goal of this clustering analysis was to select between 20-50 representative clusters to be used within the MGI assessment. However, the work that is necessary to take the cluster results and implement within the MGI assessment is very cumbersome. Therefore, an addition goal is to represent the feeder models with as few clusters (representative feeders) as possible.

To accomplish this second goal an optimization analysis was performed. The first step in the optimization analysis was to define a set of clusters within each group, defined as a specific voltage within a given region. The second step was to define the overall optimal number of clusters. The first step, define clusters within each grouping (voltage-region), was done by using the sum of squared errors (SSE) statistic.

$$SSE = \sum_{i=1}^n (x_i - \bar{x})^2 \quad (2.7)$$

where x_i represents the vector of parameters for one feeder (i), and \bar{x} is the average of all the feeders (n) within the cluster.

To illustrate the process involved within the cluster selection, an example is described in the following steps and shown in Figure 5, with the SSE within each grouping shown in Table 6.

1. within a group (e.g., region 2, volt=25 kV) form one cluster (see Figure 5)
2. calculate SSE (10.3)
3. form two clusters (see Figure 6)
 - a. compare overall SSE to previous step (5.7 VS. 10.3)
 - b. compare SSE for each cluster (4.9 and 0.7)
4. form three clusters (see Figure 7)
 - a. compare overall SSE to previous steps (3.8 VS. 5.7)
 - b. compare SSE for each cluster (0.9, 2.1, 0.7)
5. stop clustering based on SSE and number of feeders within each cluster

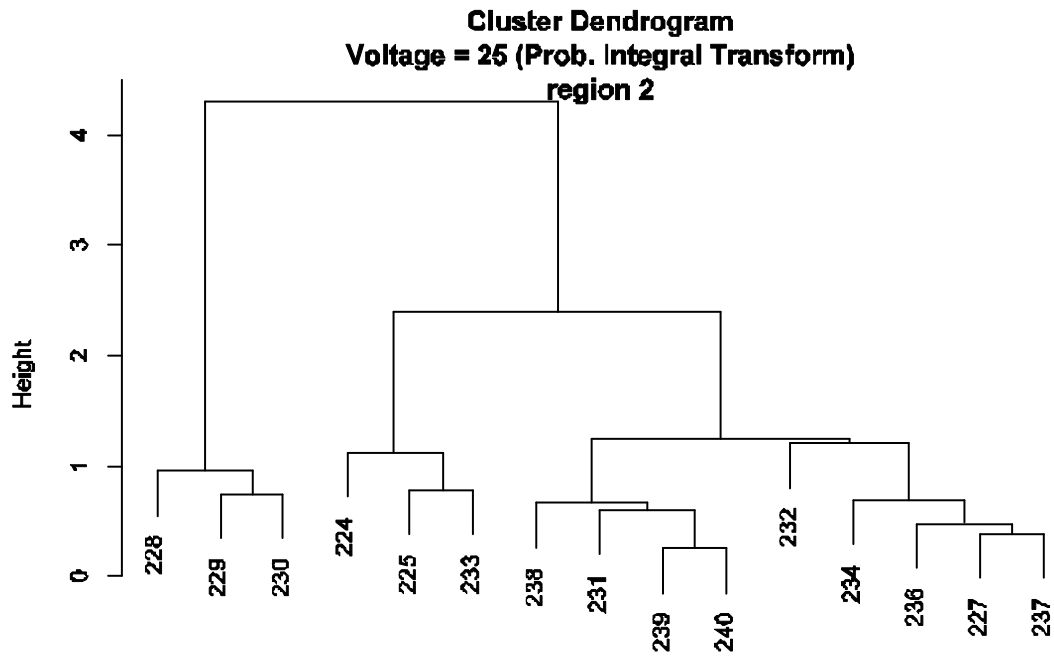

Dist(pit.fclust, "euclidean")
hclust (*, "ward")

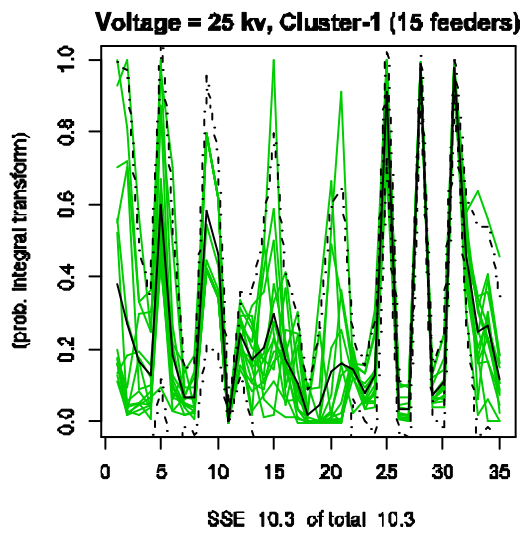
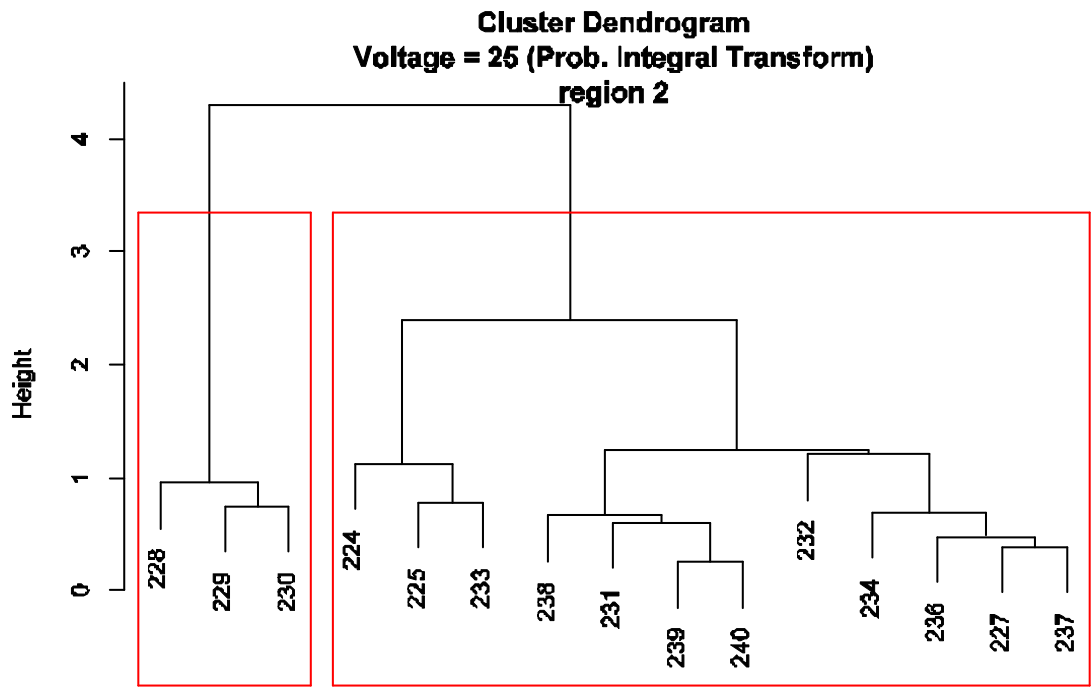

Figure 5: Cluster analysis for region 2, 25 kV, one cluster



Dist(pit.fclust, "euclidean")
hclust (*, "ward")

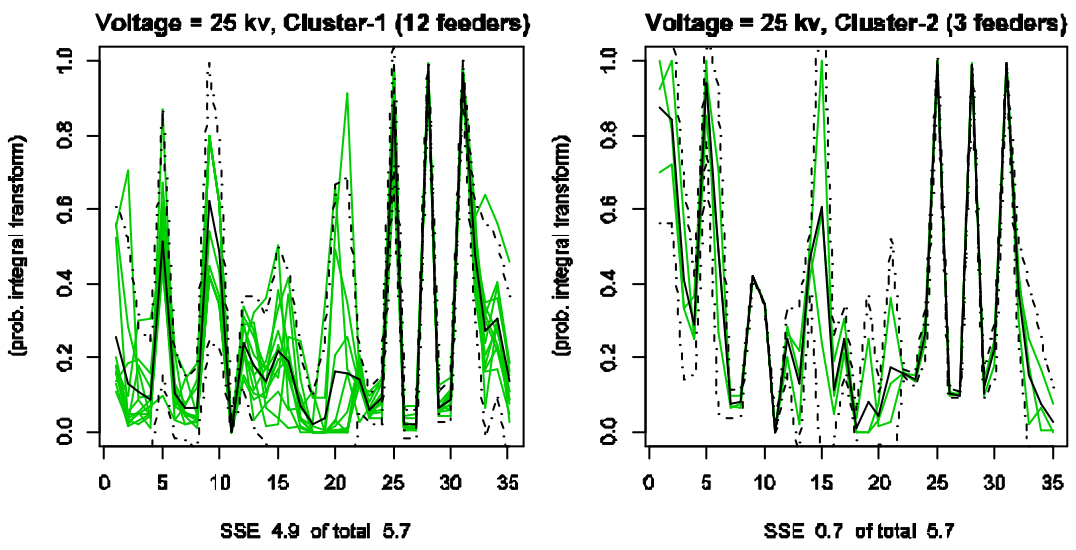

Figure 6: Cluster analysis for region 2, 25 kV, two clusters

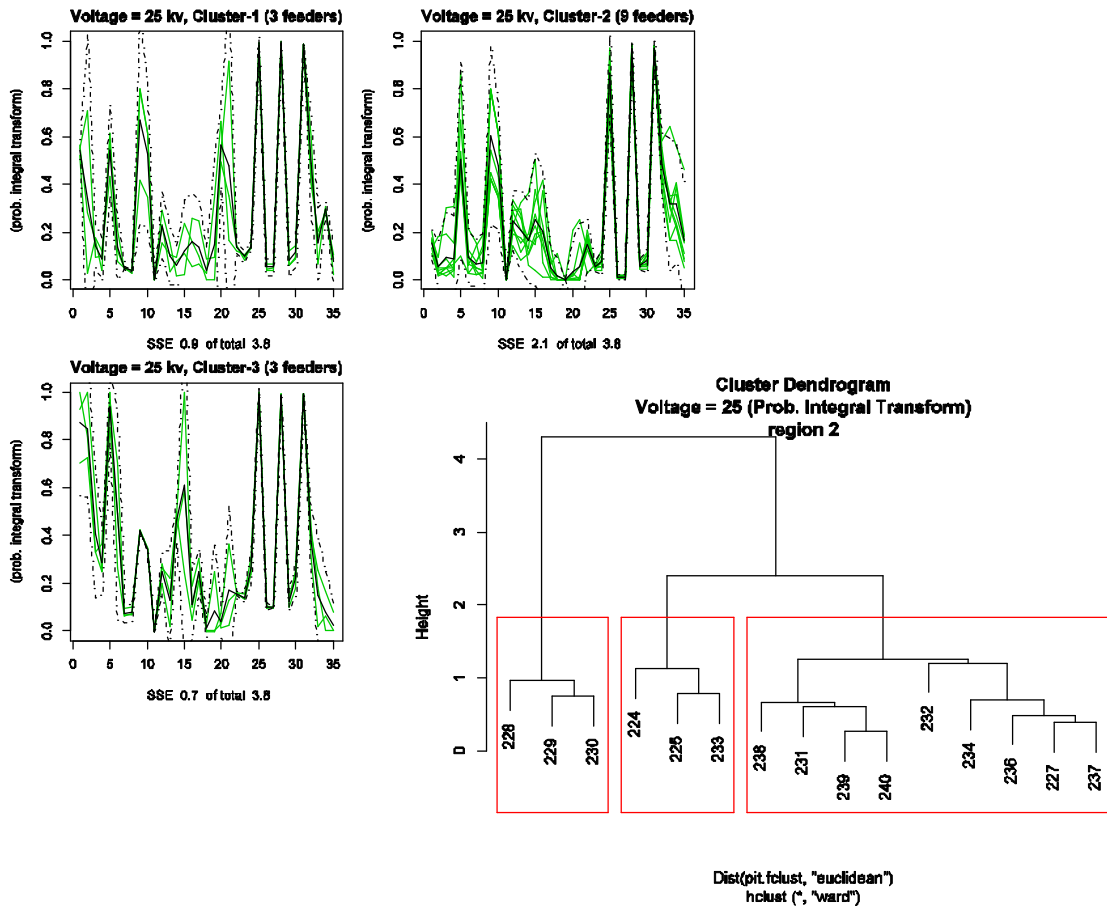

Figure 7: Cluster analysis for region 2, 25 kV, three clusters

This process is used on each grouping with the results shown in Table 5. From these results, the minimum number of clusters would be 11 (1 cluster from each grouping) where the maximum number of clusters would be 37.

Table 5: SSE within each group

	Number of Clusters				
	1	2	3	4	5
Voltage = 12.47 kV					
Region=1	44.4	33.9	27.1	23.5	20.5
Region=2	25.5	21.9	18.3	15.6	13.7
Region=3	25.5	20.7	16.6	14.7	13.3
Region=4	19.3	16.3	11	9.3	
Region=5	50.3	36.5	29.5	27.1	23.7
Voltage = 25.0 kV					
Region=1	5.9				

Region=2	10.3	5.7	3.8		
Region=4	1.7	1	0.7		
Region=5	6.2	3			
Voltage = 35.0 kV					
Region=2	1				
Region=5	12.9	9.4	6.8		

The second step of the optimization analysis (selection of final clusters) was based on the optimization of the objective function shown in equation 2.8

$$SSE_j^* = \frac{n_j}{m_j} \sum_{i=1}^{n_j} (x_i - \bar{x})^2 \quad (2.8)$$

where n_j is the number of feeders within a grouping and m_j is the number of clusters within a grouping. The optimization process starts with a single cluster within each group (11 clusters as shown in the Table 6). At each step, a cluster is added based on minimizing the objective function, SEE^* . The process continues until all 37 clusters defined in Table 6 are selected.

The final step in the optimization is to pick the optimal number of clusters. This was done by analyzing the slope of the objective function curve, shown in Figure 8. Using a method, referred to by the “Elbow Criterion” the objective function was examined looking for a point where the slope of the curve starts to decrease. From this analysis, 23 clusters were selected to represent the entire set of feeder models.

The final step of the statistical analysis was to implement these results into the evaluation of the smart grid technology. To do this, a representative feeder model will be selected for each cluster. This was done by selecting the individual feeder, within a cluster, that is closest to the average feeder of each cluster. The average feeder is calculated by taking the average of all the feeders, within a cluster, at each parameter (black curve in Figures 5-7). The closest feeder to the average is selected by the minimum distance from the average, using Euclidean distance. Figure 9 shows the closest actual feeder model, to the average, for the cluster representing region 2, 25 kV (the yellow curve)

Table 6: Optimized cluster definitions

#	SSE [*]	Voltage=12.47 kv					Voltage=25 kv				35 kv	
		Region					Region				Region	
Clusters		1	2	3	4	5	1	2	3	4	5	
11	1	1	1	1	1	1	1	1	1	1	1	1
12	0.864	1	1	1	1	2	1	1	1	1	1	1
13	0.76	2	1	1	1	2	1	1	1	1	1	1
14	0.713	2	1	2	1	2	1	1	1	1	1	1
15	0.677	2	2	2	1	2	1	1	1	1	1	1
16	0.608	2	2	2	1	3	1	1	1	1	1	1
17	0.541	3	2	2	1	3	1	1	1	1	1	1
18	0.500	3	2	3	1	3	1	1	1	1	1	1
19	0.471	3	2	3	2	3	1	1	1	1	1	1
20	0.447	3	2	3	2	4	1	1	1	1	1	1
21	0.412	4	2	3	2	4	1	1	1	1	1	1
22	0.376	4	2	3	2	4	1	1	1	1	1	1
23	0.343	4	3	3	2	5	1	1	1	1	1	1
24	0.324	4	3	4	2	5	1	1	1	1	1	1
25	0.294	5	3	4	2	5	1	1	1	1	1	1
26	0.242	5	3	4	3	5	1	1	1	1	1	1
27	0.215	5	4	4	3	5	1	1	1	1	1	1
28	0.181	5	4	4	3	5	1	1	1	1	1	1
29	0.167	5	4	5	3	5	1	1	1	1	1	2
30	0.121	5	4	5	3	5	1	2	1	1	1	2
31	0.103	5	5	5	3	5	1	2	1	1	1	2
32	0.086	5	5	5	4	5	1	2	1	1	1	2
33	0.054	5	5	5	4	5	1	2	1	2	1	2
34	0.029	5	5	5	4	5	1	2	1	2	1	3
35	0.01	5	5	5	4	5	1	3	1	2	1	3
36	0.003	5	5	5	4	5	1	3	2	2	1	3
37	0	5	5	5	4	5	1	3	3	2	1	3

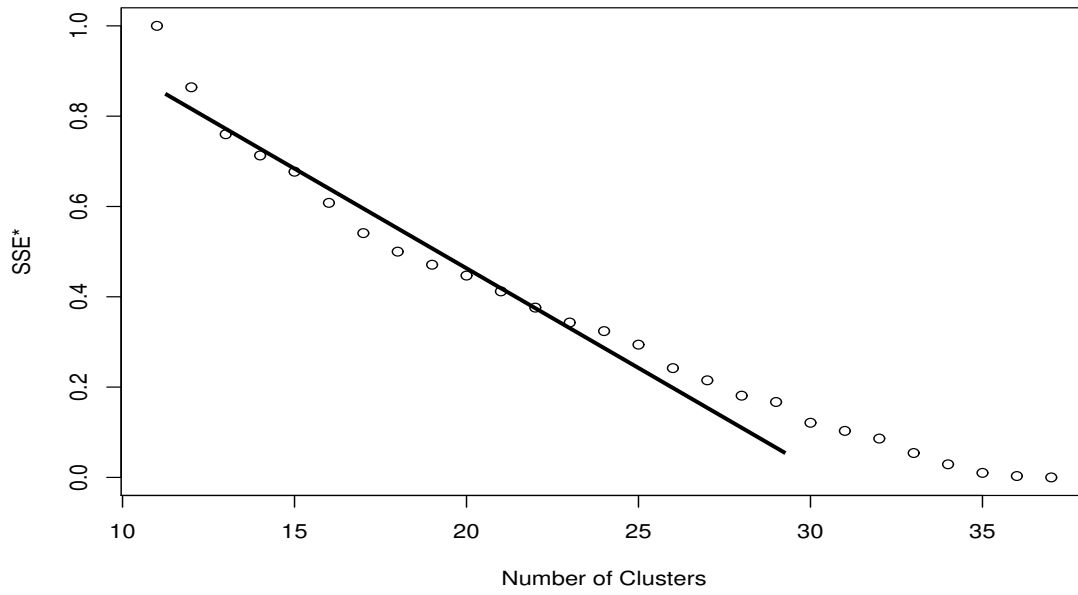

Figure 8: Plot of optimal clusters

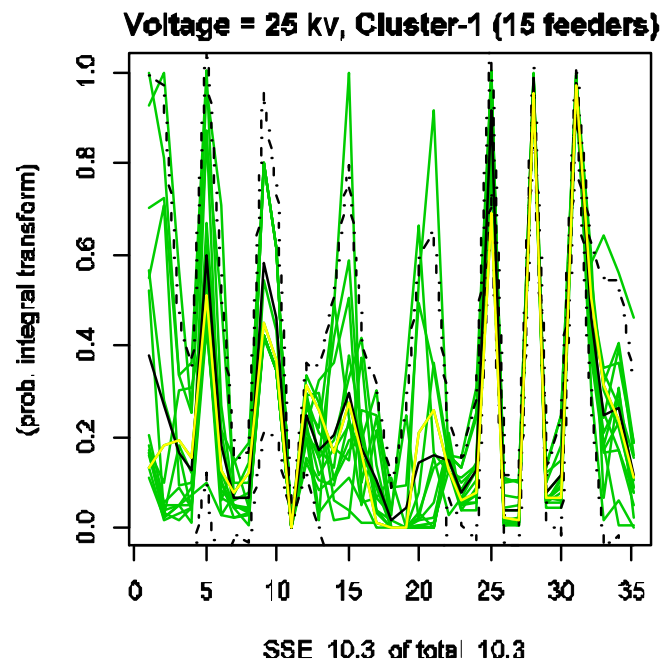

Figure 9: Best representation feeder model

3. Taxonomy Feeders

The previous section identified the utility feeders that were closest to the statistical clusters that be represented the typical feeder. These feeders were then used as a basis to construct feeders in GridLAB-D with the same characteristics, but none of the utility specific information. The effect was that prototypical feeders based on actual utility models were developed without exposing any of the proprietary utility information. This process is what allows the models to be distributed without restriction.

From the work of Section 2, 23 prototypical feeders were identified as being sufficient to represent the original 575 feeders. The determination that there we 23 appropriate feeders was based on statistical analysis and did not consider “engineering considerations”. For example, it was determined that independent of climate regions there always exists distribution feeders that supply 1 or 2 very large industrial or commercial loads. Examples of these loads include, lumber mills, shopping malls, and other large commercial complexes. Based on this a general feeder category was developed to include feeder models that can exist in any of the 5 climate regions. Currently there is 1 feeder model in the general category, bringing the total number of prototypical feeders to 24. Appendix I of this report gives detailed descriptions of the 24 prototypical feeders that constitute the MGI distribution feeder taxonomy. The actual feeder models can be obtained from a build of GridLAB-D at <http://www.gridlabd.org/downloads/> or by e-mailing Kevin Schneider at: kevin.schneider@pnl.gov.

4. Weighting Factors

Each of the prototypical feeders discussed in Appendix A is representative of a class of distribution feeders that is found in each of the climate regions. Within each of these climate regions there are tens of thousands of individual feeders, each of which can be represented by one of the prototypical feeders from the previous section. This section presents an initial set of weighting factors that gives an estimate of how many of each of the prototypical feeders exist in each region. By using these weighting factors simulations can be run on the prototypical feeders within a climate region and their individual results can be aggregated up to the regional level. For example, the effects of a new demand response methodology can be tested on the 5 prototypical feeders from climate region 1. Then using the appropriate weighting factors the results from the simulations on the 5 prototypical feeders can be used to infer the impacts on the entire region. Additionally, a utility can generate their own set of weighting factors that are specific to their service area. This information can then be used to determine if a particular smart grid technology would be beneficial to that utility. These initial weighting factors are only one set of approximations. Because complete population data is not available certain assumptions will be made. These assumptions can be changed to adjust the weighting factors.

One limitation to the weighting factors is that models for large urban centers are not represented by this set of prototypical feeders. As discussed previously, only radial distribution feeders were examined and it is common for large urban cores to have networked systems. For this reason the weighting factors for a given region will not sum to 100%. It is hoped that future work will address this important

issue.

The first step in developing the weighting factors is to determine the population living in each of the climate zones that are shown in Figures 2 and 3. To achieve this raw population information from the 2000 Census was used. The state by state population numbers along with the associated population density maps were used to determine the populations within the 5 climate regions; these numbers are shown in Table 7.

Table 7: Total population in climate regions

Region	Total est. Population
1	31,628,354
2	106,226,403
3	23,594,474
4	91,984,236
5	26,144,205

The numbers in Table 7 represent the total population as of 2000, including those living in urban centers. Because the prototypical feeders from the previous section do not include urban centers this portion of the population must be excluded. Table 8 shows an estimate for the population within each climate region, excluding urban centers, based on the assumption that 5-10% of the population is located on networked feeders. This value is an estimate because there does not exist a data base showing what percentage of the population is supplied via networked systems and what portion is supplied via radial systems.

Table 8: Non-Urban core Population in climate regions

Region	Total est. Population
1	26,884,101
2	90,292,443
3	20,055,303
4	78,186,600
5	22,222,575

Using the populations numbers listed in Table 8 in conjunction with the loading of individual feeders a set of weights is presented in Table 9.

Table 9: Prototypical feeder weightings

Region	Feeder	kV	# of feeders	% within a region
Region 1	R1-12.47-1	12.5	2,200	20.56%
	R1-12.47-2	12.47	2,500	23.36%
	R1-12.47-3	12.47	2,000	18.69%
	R1-12.47-4	12.47	1,800	16.82%
	R1-25.00-1	24.9	1,200	11.21%
	GC-12.47-1	12.47	1,000	9.35%
Region 2	R2-12.47-1	12.47	3,500	18.72%
	R2-12.47-2	12.47	3,200	17.11%
	R2-12.47-3	12.47	3,000	16.04%
	R2-25.00-1	24.9	3,500	18.72%
	R2-35.00-1	34.5	4,000	21.39%
	GC-12.47-1	12.47	1,500	8.02%
Region 3	R3-12.47-1	12.47	1,500	30.00%
	R3-12.47-2	12.47	1,500	30.00%
	R3-12.47-3	12.47	1,000	20.00%
	GC-12.47-1	12.47	1,000	20.00%
Region 4	R4-12.47-1	13.8	14,000	33.14%
	R4-12.47-2	12.5	15,000	35.50%
	R4-25.00-1	24.9	12,500	29.59%
	GC-12.47-1	12.47	750	1.78%
Region 5	R5-12.47-1	13.8	400	8.79%
	R5-12.47-2	12.47	600	13.19%
	R5-12.47-3	13.8	650	14.29%
	R5-12.47-4	12.47	500	10.99%
	R5-12.47-5	12.47	450	9.89%
	R5-25.00-1	22.9	450	9.89%
	R5-35.00-1	34.5	500	10.99%
	GC-12.47-1	12.47	1,000	21.98%

The weighting factors in Table 9 are based on estimates of population distributions derived from the 2000 Census [6] as well as estimates of the relative distribution of loads between urban, suburban, and rural areas. These estimates are rough approximations and there are numerous potential methods for developing weighting factors. While the development of these weighting factors is a rough estimate it provides a first step in an attempt to facilitate the evaluation of smart grid technologies across entire

regions.

5. Concluding Remarks

In order to modernize our nation’s electricity distribution system it will be necessary to first evaluate the technologies required to make this transition, in particular smart grid technologies. To properly evaluate the impacts of these new smart grid technologies it will be necessary to develop not only new simulation tools, such as GridLAB-D, but to disseminate models that researchers in academia and industry can use. The work presented in this report has presented a set of radial electric distribution feeder models that are openly available to researchers for the purpose of evaluating smart grid technologies.

6. Appendix I: Taxonomy of Feeders

This appendix gives descriptions of each of the 24 prototypical feeders as well as including limited equipment information. The number of nodes includes only the primary distribution system; there are additional nodes in the secondary system. The secondary system nodes are on the customer side of their service transformer. These are the nodes, and links, that model the connections from the service transformer to the service meters via triplex or other cables. As discussed earlier in section 2.2 the classification process separated the feeders into three voltage classes; 12.47 kV, 25.00 kV, and 35.00 kV. In the actual feeder models it will be seen that voltages other than these three are used. From Tables 3 and 4 it can be seen that within the 12.47 kV cluster there are 12.47 kV and 13.8 kV feeders. This fact is represented in the following feeder descriptions.

To obtain copies of the following taxonomy feeders in the GridLAB-D format visit <http://www.gridlabd.org/downloads/> or contact Kevin Schneider at kevin.schneider@pnl.gov.

6.1 Climate Region 1

Climate region 1 is the West Coast of the United States and is characterized by a temperate climate. Within climate region 1 there are 4 12.47 kV feeder types and 1 25.00 kV feeder type. The descriptions of those feeder types are as follow:

6.1.1 Feeder 1: R1-12.47-1

This feeder is a representation of a moderately populated suburban and rural area. This is composed mainly of single family residences with small amounts of light commercial. Approximately 60% of the circuit-feet are overhead and 40% are underground. It would be expected that this feeder is connected to adjacent feeders through normally open switches. For this reason it would be common to limit the feeder loading to 60% to ensure the ability to transfer load from other feeders, and vice versa. The majority of the load is located relatively near the substation.

Nodes	613
Voltage (kV)	12.5

Load (kW)	7,150
Voltage Regulators	0
Reclosers	0
Residential Transformers	432
Commercial Transformers	12
Industrial Transformers	0
Agricultural Transformers	8

6.1.2 Feeder 2: R1-12.47-2

This feeder is a representation of a moderately populated suburban and lightly populated rural area. This is composed mainly of single family residences with small amounts of light commercial. Approximately 70% of the circuit-feet are overhead and 30% underground. It would not be expected that this feeder is connected to adjacent feeders through normally open switches. Even though there are not adjacent feeders for transferring the load the total feeder loading is low because of the sparse rural loading. In this model an urban substation is feeding a rural load through a long primary circuit. The majority of the load is located relatively distant with respect to the substation.

Nodes	337
Voltage (kV)	12.47
Load (kW)	2,830
Voltage Regulators	0
Reclosers	0
Residential Transformers	227
Commercial Transformers	13
Industrial Transformers	0
Agricultural Transformers	0

6.1.3 Feeder 3: R1-12.47-3

This feeder is a representation of a moderately populated urban area. This is composed mainly of mid-sized commercial loads with some residences, mostly multi-family. Approximately 85% of the circuit-feet are overhead and 15% underground. It would be expected that this feeder is connected to adjacent feeders through normally open switches. For this reason it would be common to limit the feeder loading to 60% to ensure the ability to transfer load from other feeders, and vice versa. Since this is a small urban core the loading of the feeder is well below 60%. The majority of the load is located relatively near the substation.

Nodes	52
Voltage (kV)	12.47

Load (kW)	1,350
Voltage Regulators	0
Reclosers	0
Residential Transformers	1
Commercial Transformers	21
Industrial Transformers	0
Agricultural Transformers	0

6.1.4 Feeder 4: R1-12.47-4

This feeder is a representation of a heavily populated suburban area. This is composed mainly of single family homes and heavy commercial loads. None of the circuit-feet are overhead and 100% are underground. It would be expected that this feeder is connected to adjacent feeders through normally open switches. Due to the heavy commercial loading the feeder is loaded to near its limit. The majority of the load is located relatively near the substation.

Nodes	302
Voltage (kV)	12.47
Load (kW)	5,300
Voltage Regulators	0
Reclosers	0
Residential Transformers	38
Commercial Transformers	12
Industrial Transformers	0
Agricultural Transformers	0

6.1.5 Feeder 5: R1-25.00-1

This feeder is a representation of a lightly populated rural area. This is composed of a mixture of residential, light commercial, industrial, and agricultural loads. Approximately 60% of the circuit-feet are overhead and 40% underground. It would be expected that this feeder is not connected to adjacent feeders through normally open switches. Due to rural location and low population density the feeder is not heavily loaded. The low population density and wide area covered are why this feeder is at 25.00 kV. The majority of the load is located relatively distant with respect to the substation.

Nodes	323
Voltage (kV)	24.9
Load (kW)	2,100
Voltage Regulators	1
Reclosers	3

Residential Transformers	25
Commercial Transformers	21
Industrial Transformers	5
Agricultural Transformers	64

6.2 Climate Region 2

Climate region 2 is the North Central and North Eastern portions of the United States and is characterized by a cold climate. Within climate region 2 there are 3 12.47 kV feeder types, 1 25.00 kV feeder type, and 1 35.00 kV feeder type. The descriptions of those feeder types are as follow:

6.2.1 Feeder 6: R2-12.47-1

This feeder is a representation of a lightly populated urban area. This is composed of single family homes, moderate commercial loads, light industrial loads, and some agricultural loads. This feeder supplies a college and an airport. Approximately 25% of the circuit-feet are overhead and 75% underground. It would be expected that this feeder is connected to adjacent feeders through normally open switches. For this reason it would be common to limit the feeder loading to 60% to ensure the ability to transfer load from other feeders, and vice versa. The majority of the load is located relatively near the substation.

Nodes	482
Voltage (kV)	12.47
Load (kW)	6,050
Voltage Regulators	0
Reclosers	1
Residential Transformers	82
Commercial Transformers	80
Industrial Transformers	0
Agricultural Transformers	2

6.2.2 Feeder 7: R2-12.47-2

This feeder is a representation of a moderately populated suburban area. This is composed mainly of single family homes with some light commercial loads. Approximately 80% of the circuit-feet are overhead and 20% underground. It would be expected that this feeder is connected to adjacent feeders through normally open switches. For this reason it would be common to limit the feeder loading to 60% to ensure the ability to transfer load from other feeders, and vice versa. The majority of the load is located relatively near the substation.

Nodes	250
-------	-----

Voltage (kV)	12.47
Load (kW)	6,100
Voltage Regulators	0
Reclosers	0
Residential Transformers	161
Commercial Transformers	8
Industrial Transformers	0
Agricultural Transformers	0

6.2.3 Feeder 8: R2-12.47-3

This feeder is a representation of a lightly populated suburban area. This is composed of single family homes, light commercial loads, light industrial loads, and some agricultural loads. Approximately 20% of the circuit-feet are overhead and 80% underground. It would be expected that this feeder is connected to adjacent feeders through normally open switches. For this reason it would be common to limit the feeder loading to 60% to ensure the ability to transfer load from other feeders, and vice versa. The majority of the load is located relatively near the substation.

Nodes	768
Voltage (kV)	12.47
Load (kW)	1,400
Voltage Regulators	0
Reclosers	0
Residential Transformers	396
Commercial Transformers	6
Industrial Transformers	0
Agricultural Transformers	5

6.2.4 Feeder 9: R2-25.00-1

This feeder is a representation of a moderately populated suburban area. This is composed mainly of single family homes with some light and moderate commercial loads. Approximately 60% of the circuit-feet are overhead and 40% underground. It would be expected that this feeder is connected to adjacent feeders through normally open switches. For this reason it would be common to limit the feeder loading to 60% to ensure the ability to transfer load from other feeders, and vice versa. The majority of the load is located relatively near the substation.

Nodes	317
Voltage (kV)	24.9
Load (kW)	17,000

Voltage Regulators	0
Reclosers	0
Residential Transformers	208
Commercial Transformers	51
Industrial Transformers	0
Agricultural Transformers	28

6.2.5 Feeder 10: R2-35.00-1

This feeder is a representation of a lightly populated rural area. This is composed mainly of single family homes with some light and moderate commercial loads. Approximately 90% of the circuit-feet are overhead and 10% underground. It would be expected that this feeder is connected to adjacent feeders through normally open switches. But due to the long distances significant portions of the load cannot be shifted to adjacent feeders. In this model a single substation is serving a large geographic area, this is the reason for the higher voltage level; voltage regulators are used on this system. The majority of the load is located relatively distant with respect to the substation.

Nodes	1,031
Voltage (kV)	34.5
Load (kW)	8,900
Voltage Regulators	0
Reclosers	5
Residential Transformers	94
Commercial Transformers	5
Industrial Transformers	0
Agricultural Transformers	374

6.3 Climate Region 3

Climate region 3 is the non-coastal South West of the United States and is characterized by a hot and arid climate. Within climate region 3 there are 3 12.47 kV feeder types. The descriptions of those feeder types are as follow:

6.3.1 Feeder 11: R3-12.47-1

This feeder is a representation of a heavily populated urban area. This is composed of single family homes, heavy commercial loads, and a small amount of light industrial loads. Approximately 25% of the circuit-feet are overhead and 75% underground. It would be expected that this feeder is connected to adjacent feeders through normally open switches. Due to the heavy commercial loads it would be expected that this feeder would be loaded to a high percentage of its rating. The majority of the load is located relatively near the substation.

Nodes	633
Voltage (kV)	12.47
Load (kW)	8,400
Voltage Regulators	0
Reclosers	0
Residential Transformers	383
Commercial Transformers	58
Industrial Transformers	0
Agricultural Transformers	0

6.3.2 Feeder 12: R3-12.47-2

This feeder is a representation of a moderately populated urban area. This is composed of single family homes, light commercial loads, and a small amount of light industrial loads. Approximately 33% of the circuit-feet are overhead and 67% underground. It would be expected that this feeder is connected to adjacent feeders through normally open switches. For this reason it would be common to limit the feeder loading to 60% to ensure the ability to transfer load from other feeders, and vice versa. The majority of the load is located relatively near the substation.

Nodes	263
Voltage (kV)	12.47
Load (kW)	4,300
Voltage Regulators	0
Reclosers	3
Residential Transformers	0
Commercial Transformers	57
Industrial Transformers	5
Agricultural Transformers	0

6.3.3 Feeder 13: R3-12.47-3

This feeder is a representation of a heavily populated suburban area. This is composed mainly of single family homes with some light agricultural loads. Approximately 75% of the circuit-feet are overhead and 25% underground. It would be expected that this feeder has limited connections to adjacent feeders through normally open switches. For this reason it would be common to limit the feeder loading to 75% to ensure the ability to transfer some loads from other feeders, and vice versa. Due to the low density of suburban loads the majority of the load is located relatively distant with respect to the substation.

Nodes	2,000
-------	-------

Voltage (kV)	12.47
Load (kW)	7,800
Voltage Regulators	1
Reclosers	3
Residential Transformers	1491
Commercial Transformers	0
Industrial Transformers	0
Agricultural Transformers	107

6.4 Climate Region 4

Climate region 4 is the non-coastal South East and central areas of the United States and is characterized by a hot and cold climate. Within climate region 4 there are 2 12.47 kV feeder types, and 1 25.00 kV feeder type. The descriptions of those feeder types are as follow:

6.4.1 Feeder 14: R4-12.47-1

This feeder is a representation of a heavily populated urban area with the primary feeder extending into a lightly populated rural area. In the urban areas the load is composed on moderate commercial loads with single and multi-family residences. On the rural spur the load is primarily single family residences. Approximately 92% of the circuit-feet are overhead and 8% underground. This feeder has connections to adjacent feeders in the urban area, but limited connections in the rural areas. For this reason it would be common to limit the feeder loading to 50% to ensure the ability to transfer most of the loads from other feeders, and vice versa. Most of the urban load is located near the substation while the rural load is located at a substantial distance.

Nodes	571
Voltage (kV)	13.8
Load (kW)	5,550
Voltage Regulators	0
Reclosers	1
Residential Transformers	333
Commercial Transformers	41
Industrial Transformers	0
Agricultural Transformers	0

6.4.2 Feeder 15: R4-12.47-2

This feeder is a representation of a lightly populated suburban area with a moderately populated urban area. The lightly populated suburban area is composed mostly of single family residences. The commercial complex is a single facility. Approximately 92% of the circuit-feet are overhead and 8%

underground. This feeder has connections to adjacent feeders in the commercial complex, but limited connections in the rural areas. For this reason it would be common to limit the feeder loading to 50% to ensure the ability to transfer most of the loads from other feeders, and vice versa. Most of the suburban load is located near the substation while the commercial load is located at a substantial distance.

Nodes	263
Voltage (kV)	12.5
Load (kW)	2,200
Voltage Regulators	0
Reclosers	0
Residential Transformers	150
Commercial Transformers	21
Industrial Transformers	0
Agricultural Transformers	0

6.4.3 Feeder 16: R4-25.00-1

This feeder is a representation of a lightly populated rural area. The load is composed on single family residences with some light commercial. Approximately 88% of the circuit-feet are overhead and 12% underground. This feeder has connections to adjacent feeders. This combined with the low load density ensures the ability to transfer most of the loads from other feeders, and vice versa. Most of the load is located at a substantial distance from the substation, as is common for higher voltages in rural areas.

Nodes	230
Voltage (kV)	24.9
Load (kW)	950
Voltage Regulators	0
Reclosers	1
Residential Transformers	124
Commercial Transformers	1
Industrial Transformers	0
Agricultural Transformers	0

6.5 Climate Region 5

Climate region 5 is the South East of the United States and is characterized by a hot and humid climate. Within climate region 5 there are 5 12.47 kV feeder types, 1 25.00 kV feeder type, and 1 35.00 kV feeder type. The descriptions of those feeder types are as follow:

6.5.1 Feeder 17: R5-12.47-1

This feeder is a representation of a heavily populated suburban area and a moderate urban center. This is composed mainly of single family homes and moderate commercial loads. Approximately 95% of the circuit-feet are overhead and 5% underground. It would be expected that this feeder has connections to adjacent feeders through normally open switches. For this reason it would be common to limit the feeder loading to 50% to ensure the ability to transfer most loads from other feeders, and vice versa. The suburban load is near the substation while the commercial load is at the end of the feeder.

Nodes	265
Voltage (kV)	13.8
Load (kW)	9,400
Voltage Regulators	0
Reclosers	0
Residential Transformers	145
Commercial Transformers	26
Industrial Transformers	0
Agricultural Transformers	0

6.5.2 Feeder 18: R5-12.47-2

This feeder is a representation of a moderate suburban area with a heavy urban area. This is composed mainly of heavy commercial and single family residences. Approximately 38% of the circuit-feet are overhead and 62% underground. It would be expected that this feeder has connections to adjacent feeders through normally open switches. For this reason it would be common to limit the feeder loading to 50% to ensure the ability to transfer most loads from other feeders, and vice versa. The heavy commercial load is near the substation while the single family residences are at the end of the feeder.

Nodes	311
Voltage (kV)	12.47
Load (kW)	4,500
Voltage Regulators	0
Reclosers	0
Residential Transformers	89
Commercial Transformers	46
Industrial Transformers	0
Agricultural Transformers	0

6.5.3 Feeder 19: R5-12.47-3

This feeder is a representation of a moderately populated rural area. This is composed mainly of single family residences with some light commercial. Approximately 92% of the circuit-feet are overhead and 8% underground. It would be expected that this feeder has limited connections to adjacent feeders through normally open switches. Due to the low load density of the large rural area the feeder is less than 50% loaded. The majority of the load is located relatively distant with respect to the substation. Voltage regulators are used on this feeder.

Nodes	1,468
Voltage (kV)	13.8
Load (kW)	9,200
Voltage Regulators	1
Reclosers	20
Residential Transformers	958
Commercial Transformers	64
Industrial Transformers	0
Agricultural Transformers	0

6.5.4 Feeder 20: R5-12.47-4

This feeder is a representation of a moderately populated suburban and urban area. This is composed mainly of single family residences with some moderate commercial loads. Approximately 37% of the circuit-feet are overhead and 63% underground. It would be expected that this feeder has connections to adjacent feeders through normally open switches. For this reason it would be common to limit the feeder loading to 50% to ensure the ability to transfer most of the loads from other feeders, and vice versa. Most of the commercial load is near the substation and the residential load is spread out along the length of the entire feeder.

Nodes	643
Voltage (kV)	12.47
Load (kW)	7,700
Voltage Regulators	0
Reclosers	0
Residential Transformers	175
Commercial Transformers	31
Industrial Transformers	0
Agricultural Transformers	0

6.5.5 Feeder 21: R5-12.47-5

This feeder is a representation of a moderately populated suburban area with a lightly populated urban area. This is composed mainly of single family residences with some light commercial loads. Approximately 48% of the circuit-feet are overhead and 52% underground. It would be expected that this feeder has connections to adjacent feeders through normally open switches. For this reason it would be common to limit the feeder loading to 50% to ensure the ability to transfer most of the loads from other feeders, and vice versa. The residential load is spread out across the entire length of the feeder. The primary feeder extends a significant distance before there is any significant load. This is a configuration that can be seen in a well established system when a new feeder must be routed through an existing area in order to reach new load.

Nodes	1,075
Voltage (kV)	12.47
Load (kW)	8,700
Voltage Regulators	0
Reclosers	0
Residential Transformers	352
Commercial Transformers	28
Industrial Transformers	0
Agricultural Transformers	0

6.5.6 Feeder 22: R5-25.00-1

This feeder is a representation of a heavily populated suburban area with a moderately populated urban area. This is composed mainly of single family residences with some moderate commercial loads. Approximately 35% of the circuit-feet are overhead and 65% underground. It would be expected that this feeder has connections to adjacent feeders through normally open switches. For this reason it would be common to limit the feeder loading to 66% to ensure the ability to transfer most of the loads from other feeders, and vice versa. The residential load is spread out across the entire length of the feeder with the moderate commercial center near the substation.

Nodes	946
Voltage (kV)	22.9
Load (kW)	12,000
Voltage Regulators	0
Reclosers	0
Residential Transformers	284
Commercial Transformers	14
Industrial Transformers	0
Agricultural Transformers	0

6.5.7 Feeder 23: R5-35.00-1

This feeder is a representation of a moderately populated suburban area with a lightly populated urban area. This is composed mainly of single family residences with some moderate commercial loads. Approximately 10% of the circuit-feet are overhead and 90% underground. It would be expected that this feeder has connections to adjacent feeders through normally open switches. For this reason it would be common to limit the feeder loading to 50% to ensure the ability to transfer most of the loads from other feeders, and vice versa. The residential load is spread out across the entire length of the feeder with the moderate commercial center near the substation. This feeder is representative of a substation that is built in a “green field” where significant load growth is expected. The first feeders must go a significant distance before they reach the load. Over time the load moves towards the substation and past it.

Nodes	338
Voltage (kV)	34.5
Load (kW)	12,000
Voltage Regulators	0
Reclosers	0
Residential Transformers	188
Commercial Transformers	26
Industrial Transformers	0
Agricultural Transformers	0

6.6 General Feeders

The general feeders are feeders that are likely to be seen in any region independent of the climate. While there may be small variations between climate regions they are not significant enough, statistically, to include as independent feeder types within each region. As such the general feeders can exist in any of the 5 climate regions.

Feeder 24: GC-12.47-1

This feeder is representative of a single large commercial or industrial load, such a very large shopping mall or a lumber mill. These feeders may supply the load through a single large transformer or a group of smaller units. While there may be a couple of smaller loads the behavior of the feeder is determined by the single large customer.

Nodes	27
Voltage (kV)	12.47
Load (kW)	5,200

Voltage Regulators	0
Reclosers	0
Residential Transformers	0
Commercial Transformers	0
Industrial Transformers	3
Agricultural Transformers	0

6.7 Feeder Summary

Table 10 gives a summary of the 24 prototypical feeder models. The models are listed by their .glm file names and the base voltage, approximate feeder loading, and service area description are given.

Table 10: Summary of prototypical feeders

Feeder	kV	KVA	Description
R1-12.47-1	12.5	7152	Moderate suburban and rural
R1-12.47-2	12.47	2836	Moderate suburban and light rural
R1-12.47-3	12.47	1362	Small urban center
R1-12.47-4	12.47	5334	Heavy suburban
R1-25.00-1	24.9	2105	Light rural
R2-12.47-1	12.47	6046	Light urban
R2-12.47-2	12.47	6098	Moderate suburban
R2-12.47-3	12.47	1411	Light suburban
R2-25.00-1	24.9	17021	Moderate urban
R2-35.00-1	34.5	8893	Light rural
R3-12.47-1	12.47	8417	Heavy urban
R3-12.47-2	12.47	4322	Moderate urban
R3-12.47-3	12.47	7880	Heavy suburban
R4-12.47-1	13.8	5530	Heavy urban with rural spur
R4-12.47-2	12.5	2218	Light suburban and moderate urban
R4-25.00-1	24.9	948	Light rural
R5-12.47-1	13.8	9430	Heavy suburban and moderate urban
R5-12.47-2	12.47	4500	Moderate suburban and heavy urban
R5-12.47-3	13.8	9200	Moderate rural
R5-12.47-4	12.47	7700	Moderate suburban and urban
R5-12.47-5	12.47	8700	Moderate suburban and light urban
R5-25.00-1	22.9	12050	Heavy suburban and moderate urban
R5-35.00-1	34.5	11800	Moderate suburban and light urban
GC-12.47-1	12.47	5200	Single large commercial or industrial

7. References

1. R. S. Briggs, R. G. Lucas, Z. T. Taylor, "Climate Classification for Building Energy Codes and Standards", ASHRAE Winter Meeting, Chicago, IL, January, 2003
2. Available online: http://www.energycodes.gov/implement/pdfs/climate_paper_review_draft_rev.pdf
3. L. Kaufman and P. J. Rousseeuw, "Finding Groups in Data: An Introduction to Cluster Analysis", Wiley, New York, 1990
4. J. A. Hartigan, "Clustering Algorithms", Wiley, New York, 1975
5. Available online: <http://www.gridlabd.org/downloads/>
6. Available online: <http://www.census.gov/main/www/cen2000.html>