This is an electronic reprint of the original article.
This reprint may differ from the original in pagination and typographic detail.

Author(s): Hinkkanen, M. & Luomi, J.

Title: Modified integrator for voltage model flux estimation of induction motors

Year: 2003

Version: Post print

Please cite the original version:

Hinkkanen, M. & Luomi, J. 2003. Modified integrator for voltage model flux estimation of induction motors. IEEE Transactions on Industrial Electronics. Volume 50, Issue 4. 818-820. ISSN 0278-0046 (printed). DOI: 10.1109/tie.2003.814996.

Rights: © 2003 Institute of Electrical & Electronics Engineers (IEEE). Personal use of this material is permitted. Permission from IEEE must be obtained for all other uses, in any current or future media, including reprinting/republishing this material for advertising or promotional purposes, creating new collective works, for resale or redistribution to servers or lists, or reuse of any copyrighted component of this work in other work.

All material supplied via Aaltodoc is protected by copyright and other intellectual property rights, and duplication or sale of all or part of any of the repository collections is not permitted, except that material may be duplicated by you for your research use or educational purposes in electronic or print form. You must obtain permission for any other use. Electronic or print copies may not be offered, whether for sale or otherwise to anyone who is not an authorised user.

Modified Integrator for Voltage Model Flux Estimation of Induction Motors

Marko Hinkkanen and Jorma Luomi, *Member, IEEE*

Abstract—This paper deals with voltage model flux estimators for sensorless induction motor drives. In order to eliminate the drift problems, the pure integrator of the voltage model is replaced with a first-order low-pass filter, and the error due to this replacement is compensated in a very simple way.

Index Terms—Induction machines, AC motor drives, flux estimation.

I. INTRODUCTION

The voltage model is a convenient flux estimator for sensorless induction motor drives because of its simplicity, and since the only crucial parameter of the model is the stator resistance. The voltage model is often used in stator flux oriented control [1], but it can also be used for rotor flux oriented control [2]. However, there are two well-known problems when the voltage model is used: even a small dc offset in measured currents causes drift problems if a pure integrator is used and, at low speeds, the model is extremely sensitive to errors in the stator resistance value and to measurement errors. This paper concentrates on the problems of integration, which can be overcome by modifying the integrator.

Various modifications of the integrator have been proposed in the literature [2]–[6]. The simplest way to eliminate the drift problems is to replace the pure integrator with a low-pass filter [2]. However, this method causes the output to be erroneous even in steady state. The error can be compensated, as presented in [5], by turning the angle and changing the magnitude of the output vector of the low-pass filter according to the calculated error. However, speed reversals are problematic.

The method proposed in this paper is inspired by the method presented in [5]. Problems in speed reversals are avoided by carrying out the compensation before low-pass filtering, and a computationally more effective way to calculate the compensation is presented. The proposed flux estimation method is suitable for applications where a low-cost drive is required but field orientation control is preferred due to the dynamic performance needed.

II. INDUCTION MOTOR MODEL

The dynamic model corresponding to the inverse- Γ equivalent circuit of the induction motor will be used below. The voltage equations are in a general reference frame

$$\underline{u}_s = R_s \dot{\underline{i}}_s + \frac{d\underline{\psi}_s}{dt} + j\omega_k \underline{\psi}_s \quad (1)$$

$$\underline{u}_R = R_R \dot{\underline{i}}_R + \frac{d\underline{\psi}_R}{dt} + j(\omega_k - \omega_m) \underline{\psi}_R = 0 \quad (2)$$

The conference version of this work was presented in the 27th Annual Conference of the IEEE Industrial Electronics Society (IECON'01), Denver, CO, Nov./Dec. 2001, vol. 2, pp. 1339–1343. This work was financed in part by ABB Oy and in part by the Foundation of Technology, Finland.

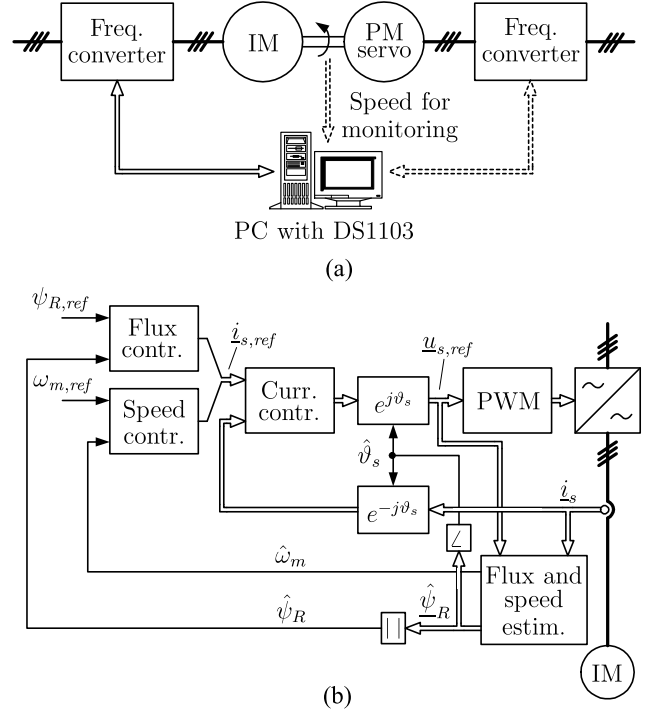

Fig. 2. Experimental setup (a). The PM servo motor was used as the loading machine. The rotor flux oriented controller (b). The electrical variables shown on the left-hand side of the coordinate transformations are in the estimated flux reference frame and the variables on the right-hand side are in the stator reference frame.

where ω_k is the angular speed of the reference frame, ω_m the electrical angular speed of the rotor, \underline{u}_s the stator voltage, $\dot{\underline{i}}_s$ the stator current, and R_s the stator resistance. For the rotor, \underline{u}_R , $\dot{\underline{i}}_R$, and R_R are defined similarly. The stator and rotor flux linkage equations are

$$\underline{\psi}_s = (L'_s + L_M) \dot{\underline{i}}_s + L_M \dot{\underline{i}}_R \quad (3)$$

$$\underline{\psi}_R = L_M (\dot{\underline{i}}_s + \dot{\underline{i}}_R) \quad (4)$$

where L_M and L'_s are the magnetizing inductance and the stator transient inductance, respectively.

III. VOLTAGE MODEL AND MODIFIED INTEGRATORS

A. Voltage Model

The voltage model for the stator flux estimate can be written from (1) in the stator reference frame, i.e., $\omega_k = 0$, as

$$\dot{\underline{\psi}}_s = \int (\underline{u}_s - \hat{R}_s \dot{\underline{i}}_s) dt \quad (5)$$

where \hat{R}_s is the stator resistance estimate. Based on (3) and (4), the rotor flux estimate is obtained from the stator flux

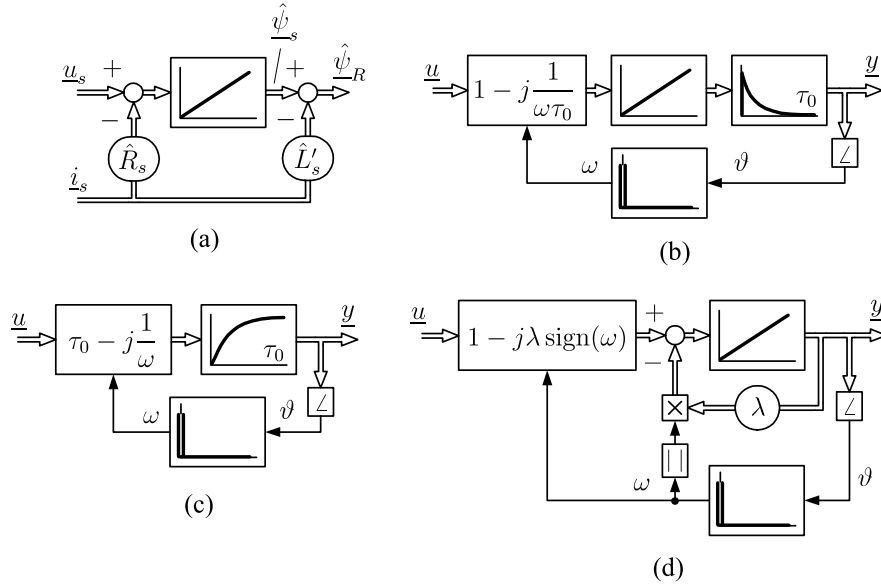

Fig. 1. Voltage model for the rotor flux (a), two structures for the compensated low-pass filter with the constant time constant τ_0 (b), (c), and the proposed algorithm (d).

estimate as $\hat{\psi}_R = \hat{\psi}_s - \hat{L}'_s i_s$. The voltage model for the rotor flux is shown in Fig. 1(a).

B. Proposed Modified Integrator

In the following, the input signal is denoted by $\underline{u} = \underline{u}_s - \hat{R}_s \underline{i}_s$ and the output signal by $\underline{y} = \hat{\psi}_s$. The pure integrator is thus $\underline{y} = \int \underline{u} dt$. The goal is to modify the integrator in such a way that the frequency response function of the modified integrator remains the same as that of the pure integrator, i.e.,

$$\frac{\underline{y}(j\omega)}{\underline{u}(j\omega)} = \frac{1}{j\omega} = \frac{1}{|\omega|} e^{-j\frac{\pi}{2} \text{sign}(\omega)} \quad (6)$$

where ω is the angular frequency of the output signal \underline{y} . In the following, the proposed algorithm is derived by using intermediate steps presented in Figs. 1(b)–(d). A short discussion of the differences between the proposed algorithm and the one presented in [5] is given at the end of this section.

A first-order high-pass filter with the time constant τ_0 , i.e., $\tau_0 s / (\tau_0 s + 1)$, can be added in series to the pure integrator to remove the drift problems [2]. The steady-state error caused by the high-pass filter can be compensated by multiplying the input signal of the integrator by the inverse of the high-pass filter frequency response (Fig. 1(b)). The combination of the first-order high-pass filter and the integrator is equal to a first-order low-pass filter amplified by the time constant τ_0 (Fig. 1(c)). The next step is to choose the time constant to be dependent on the angular frequency ω by taking $\tau_0 = 1/\alpha_0 = 1/(\lambda |\omega|)$, where α_0 is the corner angular frequency and λ is a positive constant [5].

Now the equation for the modified integrator can be written in the low-pass filter form

$$\frac{1}{\lambda |\omega|} \frac{dy}{dt} + y = \frac{1 - j\lambda \text{sign}(\omega)}{\lambda |\omega|} \underline{u} \quad (7)$$

or in the integral form $y = \int \{ [1 - j\lambda \text{sign}(\omega)] \underline{u} - \lambda |\omega| y \} dt$, which is illustrated in Fig. 1(d). The constant λ is typically

chosen $\lambda = 0.1 \dots 0.5$. The transient behavior is good if λ is small, but a higher value of λ allows more dc offset in the measurements. The pure integration is achieved by choosing $\lambda = 0$.

In the ideal case when no dc offset exists and the parameter \hat{R}_s is exactly correct, the response of the proposed algorithm corresponds very well to that of the pure integrator. Even though the derivation of the algorithm was based on the assumption of steady state, practically no deterioration of the flux estimation can be observed during transients. The angular frequency ω is not low-pass filtered at all, which is one reason for good dynamic behavior. When a small dc offset in the measurements or a moderate parameter error in \hat{R}_s is present, the algorithm remains stable and no drift problems exist. This is due to shifting the poles of the pure integration from the origin to $-\lambda |\omega|$.

It is important to note that the proposed algorithm (7) is extremely simple. The simple complex-valued compensation gain $1 - j\lambda \text{sign}(\omega)$ is used instead of calculating the phase error and the gain error as in [5]. Furthermore, the dynamics of (7) differ from [5, Fig. 2] because the compensation is carried out before the low-pass filter. Therefore, problems after speed reversals are avoided and a smoother output is obtained. The steady-state responses of both methods correspond to the ideal integrator.

IV. CONTROL SYSTEM

The proposed algorithm was investigated by means of simulations and experiments. The MATLAB/Simulink environment was used for the simulations. The experimental setup is shown in Fig. 2(a). A 2.2-kW four-pole 400-V 50-Hz induction motor was fed by a frequency converter controlled by a dSpace DS1103 PPC/DSP board.

The control system shown in Fig. 2(b) was based on the direct rotor flux orientation and synchronous-frame current

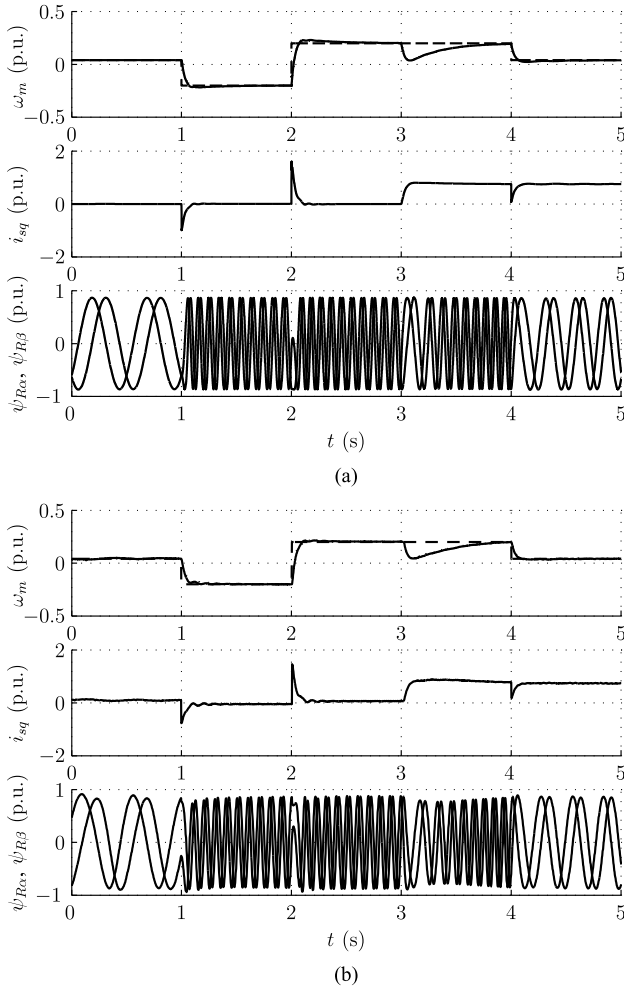

Fig. 3. Simulation (a) and experimental (b) results for the proposed algorithm. The value of λ was 0.33. The first subplot shows the actual speed (solid), the speed reference (dashed), and the estimated speed (dotted). The second subplot shows the actual q -component of the stator current in the estimated flux reference frame. The third subplot presents the components of the estimated rotor flux in the stator reference frame.

control. The angular speed of the rotor was estimated by using the slip relation $\hat{\omega}_m = \hat{\omega}_s - \hat{R}_R i_{sq} / \hat{\psi}_R$, where $\hat{\omega}_s$ is the angular speed of the estimated rotor flux, i_{sq} is the torque producing current component, and $\hat{\psi}_R$ is the magnitude of the estimated rotor flux. The calculated rotor speed was filtered by a first-order low-pass filter. The bandwidths of the current controller, filtering of the speed estimate, speed controller, and flux controller were 8 p.u., 1 p.u., 0.1 p.u., and 0.01 p.u., respectively (the base value being $2\pi \cdot 50 \text{ s}^{-1}$).

For simplicity, the rotor flux speed estimate was used in the proposed integrator (7) instead of the more correct stator flux speed estimate. This approximation has no effect in the steady state and only a marginal effect on the dynamic performance. The sampling was synchronized to the modulation and both the switching frequency and the sampling frequency were 5 kHz. The dc-link voltage was measured, and the reference stator voltage obtained from the current controller was used for the voltage model. A simple current feedforward dead-time compensation was applied [7].

V. RESULTS

An example of simulation results for the proposed algorithm is shown in Fig. 3(a). The speed reference was initially set to 0.04 p.u. and a speed reversal to -0.2 p.u. was applied ($t = 1$ s). The speed reference was changed to 0.2 p.u. ($t = 2$ s) and a rated-load torque step was applied ($t = 3$ s). Finally, the speed reference was lowered to 0.04 p.u. ($t = 4$ s) while the rated torque was still applied. Both the steady-state and dynamic performance are good.

Fig. 3(b) shows experimental results corresponding to the simulation of Fig. 3(a). It can be seen that the experimental results correspond very well to the simulation. If a more accurate dead-time compensation scheme utilizing the measured voltages [8] were used, the results would be still better.

As a comparison, the system using the pure integrator became unstable after $t = 2$ s in the corresponding experiment due to dc components in the measured currents. Compared with the method in [5, Fig. 2], a serious transient phenomenon in the flux estimate is eliminated after speed reversals. To obtain satisfactory behavior after speed reversals, careful filtering of $\hat{\omega}_s$ or some other means is needed in the method in [5].

VI. CONCLUSIONS

A new version of the modified integration algorithm was presented in this paper. The properties of the algorithm are: (a) the poles of the pure integration are shifted from the origin to $-\lambda|\omega|$, (b) the drift and the marginal stability problem of the pure integration are eliminated, (c) neither the steady-state nor the dynamic response of the integration is deteriorated due to modifications of the pure integrator, and (d) the algorithm is very simple. It is, however, to be noted that the inherent parameter sensitivity properties of the voltage model still remain. The accuracy of the stator resistance estimate thus affects the accuracy of the estimated flux.

REFERENCES

- [1] X. Xu and D.W. Novotny, "Implementation of direct stator flux orientation control on a versatile DSP based system," *IEEE Trans. Ind. Applicat.*, vol. 27, no. 4, pp. 694–700, July/Aug. 1991.
- [2] K.D. Hurst, T.G. Habetler, G. Griva, and F. Profumo, "Zero-speed torqueless IM torque control: Simply a matter of stator voltage integration," *IEEE Trans. Ind. Applicat.*, vol. 34, no. 4, pp. 790–795, July/Aug. 1998.
- [3] B.K. Bose and N.R. Patel, "A programmable cascaded low-pass filter-based flux synthesis for a stator flux-oriented vector-controlled induction motor drive," *IEEE Trans. Ind. Electron.*, vol. 44, no. 1, pp. 140–143, Feb. 1997.
- [4] J. Hu and B. Wu, "New integration algorithms for estimating motor flux over a wide speed range," *IEEE Trans. Power Electron.*, vol. 13, no. 5, pp. 969–977, Sept. 1998.
- [5] M.-H. Shin, D.-S. Hyun, S.-B. Cho, and S.-Y. Choe, "An improved stator flux estimation for speed sensorless stator flux orientation control of induction motors," *IEEE Trans. Power Electron.*, vol. 15, no. 2, pp. 312–318, Mar. 2000.
- [6] J. Holtz and J. Quan, "Sensorless vector control of induction motors at very low speed using a nonlinear inverter model and parameter identification," in *Conf. Rec. IEEE-IAS Annu. Meeting*, Chicago, IL, Sept./Oct. 2001, vol. 4, pp. 2614–2621.
- [7] J.K. Pedersen, F. Blaabjerg, J.W. Jensen, and P. Thogersen, "An ideal PWM-VSI inverter with feedforward and feedback compensation," in *Proc. EPE'93*, Brighton, U.K., Sept. 1993, vol. 4, pp. 312–318.
- [8] Y. Murai, T. Watanabe, and H. Iwasaki, "Waveform distortion and correction circuit for PWM inverters with switching lag-times," *IEEE Trans. Ind. Applicat.*, vol. IA-23, no. 5, pp. 881–886, Sept./Oct. 1987.