

**D**ANISH **R**ESearch **U**NIT FOR **I**NDUSTRIAL **D**YNAMICS

DRUID Working Paper No 00-4

**Modularization assessment of product  
architecture**

by  
Juliana Hsuan Mikkola  
May 2000

# Modularization assessment of product architecture

by

*Juliana Hsuan Mikkola*

*DRUID*

Dept. of Industrial Economics and Strategy

Copenhagen Business School

Howitzvej 60

DK-2000 Frederiksberg

Denmark

Tel: +45 3815 2941

Fax: +45 3815 2540

Email: [jh.ivs@cbs.dk](mailto:jh.ivs@cbs.dk)

## Abstract

Modularization refers to the opportunity for mixing-and-matching of components in a modular product design in which the standard interfaces between components are specified to allow for a range of variation in components to be substituted in a product architecture. It is through mixing-and-matching of these components, and how these components interface with one another, that new systems are created. Consequently, the degree of modularization inherent in a system is highly dependent upon the components and the interface constraints shared among the components, modules, and sub-systems. In this paper, a mathematical model is derived for analyzing the degree of modularization in a given product architecture by taking into consideration the number of components, number of interfaces, the composition of new-to-the-firm (NTF) components, and substitutability of components. An analysis of Chrysler windshield wipers controller suggests that two product architectures may share similar interface constraints, but the opportunity for modularization of one module is significant higher than the other due to the higher substitutability of its components and lower composition of NTF components.

## Key words:

Product architecture, modularization, substitutability, new product development

**JEL:** L23, L62, O32

**ISBN(87-7873-088-0)**

Comments are welcomed. This paper was presented at the DRUID's 2000 Winter Conference in Hillerød, Denmark. The author wishes to thank the constructive and encouraging feedback received at the conference. Special thanks are indebted to Didier Chabaud and Marco Valente who provided me with valuable insights. Whenever possible, their comments were incorporated in this manuscript.

# CONTENTS

<b>INTRODUCTION.....</b>	<b>4</b>
<b>1. RELATED LITERATURE .....</b>	<b>6</b>
<b>1.1 Definitions of architecture.....</b>	<b>6</b>
<b>1.2 Modularization.....</b>	<b>6</b>
1.2.1 Advantages of Modularization .....	7
1.2.2 Constraints Imposed by Modularization .....	8
<b>2. IN-HOUSE DEVELOPMENT VERSUS OUTSOURCING.....</b>	<b>8</b>
<b>2.1 The Role of Modular Innovation in Black-Box Design.....</b>	<b>11</b>
<b>3. THE MODEL.....</b>	<b>12</b>
<b>3.1 Assessment of Modularization in a Product Architecture of a Black-Box.....</b>	<b>14</b>
<b>3.2 Modularization Function Formulation .....</b>	<b>14</b>
<b>3.3 Estimating the Interface Constraint Factor, <math>\delta</math> .....</b>	<b>16</b>
<b>4. CASE ILLUSTRATION.....</b>	<b>17</b>
<b>5. CONCLUSION.....</b>	<b>22</b>
<b>DANISH RESEARCH UNIT FOR INDUSTRIAL DYNAMICS.....</b>	<b>28</b>

## Introduction

The increasing complexity of technologies and their applications in addition to emergence of new business practices, such as strategic alliances, are forcing firms to rely on research and development (R&D) as a source of strategy. Not only firms must be able to predict the shift of customer preferences towards higher product variation and customization, at the same time they must refocus their marketing and supply chain management strategies to ensure proper commercialization and distribution of their products. How dependent has competitive strategies of a firm become on new product development (NPD) strategies and vice-versa? What are some of the new challenges faced by marketing and distribution in ensuring desired commercialization of high-variety-high-customization of new products? How are firms coping with these challenges? No doubt, NPD strategies play a crucial role. Some firms, for instance, seek to find leverage from their manufacturing processes such as mass customization<sup>1</sup> and postponement<sup>2</sup> strategies.

In this paper, the concept of *modularization* as a NPD strategy is examined for assessing the design of architecture at the detailed product design level. *Modularization* is defined as the opportunity for mixing-and-matching of components in a modular product design in which the standard interfaces between components are specified to allow for a range of variation in components to be substituted in a product architecture. Modularization can significantly reduce manufacturing processes and assemblies leading to increased product variety and customization. It is through mixing-and-matching of these components, and how these components interact with one another, that new systems are created. Naturally, issues regarding decomposability and integration of components vis-à-vis interface management of these components become an important factor. In a modular design strategy (as opposed to integral design strategy), decomposability of the components and interface compatibility issues must be seriously considered. Consequently, the degree of modularization inherent in a product is highly dependent upon the number of components and the interface constraints shared among the components, modules, sub-systems, and systems. However, there is very little evidence from the literature providing a systematic way to analyze modularization at the detailed engineering level and how it impacts interface management in platform designs. How can firms manage modularity of its products without understanding the basic relationship between components and interfaces at the root of product architecture?

---

<sup>1</sup> Mass customization emphasizes the need to provide outstanding service to customers in providing products that meet customers' needs (through maximizing individual customization) at a low cost (through modular components) (Feitzinger and Lee, 1997; Gilmore and Pine, 1997; Kotha, 1995; Pine 1993).

<sup>2</sup> Bowersox (1982) defined postponement as a "dimension of the sequence, timing and scale of operation necessary to support differentiated marketing. At the root of postponement is the economic principle of substitutability: (1) postpone changes in form and identity to the latest possible point in the distribution system, and (2) postpone changes in inventory location to the latest possible point in time."

Systems in general are constrained by interface compatibility factors shared among the components. Although the complexity of a given product architecture is dependent upon many factors such as technology, know-how of designers, manufacturing capabilities, etc., the core of its complexities are inherent from basic components and how these components interface with each other. The complexity of a system is accentuated by the introduction of new-to-the-firm (NTF) components<sup>3</sup>. The insertion of NTF components into a given product architecture introduces uncertainty in interface specification with respect to other components as well as in designing manufacturing processes to accommodate the assembly of such devices. Clark's (1989) study of automotive industry showed that the combination of a high fraction of unique parts and significant engineering work done in-house creates a complex planning process that requires more time to complete. Clark also argued that the planning process would be more complex with greater use of unique components implying that the design problems would be intrinsically harder and involve more people. Such issues are likely to extend beyond engineering problems to include additional uncertainties with manufacturing investment and perhaps product policy.

It is important to note, however, that because each component has a specific function, modularization at the detailed product architecture level, is not only about mixing-and-matching of these components but also how these components are configured vis-à-vis other components in order to arrive at the desired performance and functionality. The subsequent generation of product variants from common product architecture is inherent in the architecture of the system manifested by the complex linkages among components. In other words, the number of components and interfaces shared among these components determine the elementary complexity of product architectures. Moreover, provided that interfaces between components comprising a system becomes standardized then the complexity of components can be reduced.

In this paper, I focus on the issue of modularization in new product development at the detailed design level, taking as the unit of analysis a black box of which the functional specification (including planning activities) is set by the buyer while the detailed engineering (including design, purchasing, and manufacturing activities) is the responsibility of the supplier. In addition, a mathematical model is derived for analyzing the degree of modularization in a given product architecture by taking into consideration the following variables: number of components, number of interfaces, NTF component composition, and substitutability factor. The paper is organized as follows. Firstly, a brief discussion of literature on architecture and modularization is presented, followed by an introduction of a framework for defining supplier involvement in engineering, especially the role of modular innovation in black box design. Secondly, the modularization model is derived vis-à-vis the formulation for estimating the interface constraint factor. Finally, the application of the mathematical model is illustrated with two product architectures of Chrysler Jeep's windshield wipers controller.

---

<sup>3</sup> Although a NTF component is treated as a unique component by the firm, it is not necessarily a new-to-the-world component. Hence, a NTF component in one firm may well be a standard component in another firm.

## 1. Related Literature

### 1.1 Definitions of architecture

The term 'architecture' has different connotations in information systems (IS) and NPD literatures. In IS, the term architecture refers to the basic hardware, software, and network systems in the organization (Lucas, 1997:123). For example, an application architecture (AA) is a graphical model showing the major applications which make up or will make up an organization's integrated information system, and how these applications relate to each other in terms of the data flows between them. The AA serves management communication needs during IS planning and later enables development of application in an integrated manner (Periasamy and Feeny, 1997:343).

In NPD literature, 'architecture' focus on physical components and their linkages and interactions to other components. For instance, Ulrich (1995) defined product architecture as the scheme by which the function of the product is allocated to physical components, that is, the arrangement of functional elements, the mapping from functional elements to physical components, and the specification of the interfaces among interacting physical components. Similarly, Christensen and Rosenbloom (1995) defined products as systems comprised of components which relate to each other in a designed architecture. Each component can also be viewed as a system, comprising sub-components whose relationships to each other are also defined by a design architecture. Moreover, Hsuan (1999a) makes the distinction between open- versus close-architecture components. Open-architecture components are not self-contained, but a function of networked parts working together where technological interdependencies shared among these components are crucial. Close-architecture components are usually supported by a set of open-architecture components in order to achieve full functionality and performance.

The term product architecture is sometimes referred to as 'product platform.' According to Meyer and Utterback (1993), a product platform encompasses the design and components shared by a set of products. They defined a product family as products that share a common platform but having specific feature and functionality required by different sets of customers.

### 1.2 Modularization

The term 'modularization' refers to *modularity* (Baldwin and Clark, 1997; Sanchez and Mahoney, 1996; Meyer and Utterback; 1993), *modular innovation* (Hsuan, 1999a; Christensen and Rosenbloom, 1995; Henderson and Clark, 1990), *modular system* (Baldwin and Clark, 1997; Langlois and Robertson, 1992), *modular components* and *modular product design* (Schaefer, 1999; Sanchez and Mahoney, 1996; Sanchez, 1994), *modular product architecture* (Sanchez and Mahoney, 1996; Lundqvist et al., 1996; Ulrich and Eppinger, 1995), and *remodularization* (Lundqvist et al., 1996).

For instance, Schaefer (1999) stated that "modular design is characterized by design groups separated by standardized interfaces that govern how sub-systems are to fit

together into a whole product ... [allowing] the firm to ‘mix-and-match’ components from various versions of the product.” He used the results on supermodular functions by explicitly considering how the interactions between components might affect the process of partitioning components into research groups. Meyer and Utterback (1993), on the other hand, highlighted the importance that early planning and development of new product platforms must also be coupled with high levels of modularity in designs and emphasis on layering technologies within an overall product architecture. Modularity in designs allows a firm to more readily focus on critical areas of proprietary technology to advance internally. Modularity also allows a firm to upgrade components with newer and better variations from suppliers.

Modularization in this paper refers to the opportunities for mixing-and-matching of components in a modular product design, in which the standard interfaces between components are well specified to allow for a range of variations in components to be substituted in a product architecture (Hsuan 1999a, 1999b). Mixing-and-matching of components is only possible when interfaces shared among these components become standardized. That is, the specification of the interfaces have to be well defined with tolerances wide enough allowing a component to interface with another component without compromising the functionality of the new component created by the combination of these components.

### *1.2.1 Advantages of Modularization*

The advantages of modularization are highly discussed in the literature. According to Baldwin and Clark (1993), modularity boots the rate of innovation, as it shrinks the time business leaders have to respond to competitors’ moves, and modularity in use can spur innovation in design as the manufacturers can independently experiment with new product and concepts. Schaefer (1999) focus on modularity’s role in increasing product variety. Modular design can reduce the cost of enhancing the variety of a product line, if combining old and new versions of various subsystems results in distinct versions of the product. The process of mixing-and-matching can aid the firm in learning about the interactions between components. The use of modular components not only provide a large number of variations, it also reduces overall manufacturing costs (Shirley, 1990).

A modular system allows consumers to take advantage of interchangeable components rather than having to accept an entire package that is pre-chosen by the manufacturer. Modular systems also encourage vertical specialization leading to the establishment of network of producers. A decentralized network based on modularity can have advantages on innovation in trying out alternate approaches simultaneously leading to rapid trial-and-error learning. Modular system may progress faster technologically, especially during periods of uncertainty and fluidity. Modularity promotes division of labor as a network with a standard of compatibility promotes autonomous innovation. A modular system can blanket the product space with little loss in production or transaction costs (at least with microcomputers) (Langlois and Robertson, 1992). Sanchez and Mahoney (1996) also mentioned the advantage of using a modular product architecture to coordinate development processes as a means to quickly link together the resources and capabilities of many organizations to form

product development 'resource chains' that can respond flexibly to environmental change.

### ***1.2.2 Constraints Imposed by Modularization***

Modularity is achieved by partitioning information into visible design rules and hidden design parameters, and it is beneficial only if the partition is precise, unambiguous, and complete. Modular systems are more difficult to design than comparable interconnected systems. One problem is that the designers of modular systems must know a great deal about the inner workings of the overall product or process in order to develop the visible design rules necessary to make the modules function as a whole. Another problem is that imperfect modularization tends to appear only when the modules come together and function meagerly as an integrated whole. Furthermore, firms that choose to pursue modular design efforts must be adept at formulating new financial relationships and employment contracts, and they must enter into innovative technology ventures and alliances (Baldwin and Clark, 1997). It has also been argued that the use of standardized components to support mass customization may increase the cost of materials (Feitzinger and Lee, 1997).

Systemic innovation is more difficult in modular systems to the extent it can destroy compatibility across components, as such innovation is expected to take place within the externally compatible components (Langlois and Robertson, 1992). Furthermore, systemic innovation in modular systems is expected to vary depending on the nature of supplier-buyer relationships. For firms pursuing durable-arm's-length type of relationships, the products are often open-architecture, commodity products with few interaction effects with other inputs. In contrast, firms pursuing strategic partnerships with its suppliers, products are often closed-architecture with high level of customization sharing multiple interaction effects with other inputs, consequently interface constraints are at their maximum. Hence, the modularity decisions must be made accordingly to the degree of supplier-buyer interdependence, the degree of component customization, value inputs, and interface compatibility effects (Hsuan 1999a).

## **2. In-House Development Versus Outsourcing**

When a new project has been given the green light to start the development, its activities and processes can be analyzed in three stages: planning, design and manufacturing. The planning phase activities are often related to the definition of functional specification of the new product such as general product definition, lead time requirements, and definition of interface specifications. The design and manufacturing stages are often referred to as the detailed engineering phase where bill of materials and blue prints are generated, prototypes are built and tested, manufacturing processes and equipment are selected and qualified, and so on, as shown in Figure 1.

A component is defined as a physically distinct portion of the product that embodies a core design concept (Clark, 1985) and performs a well-defined function (Henderson and Clark, 1990). The maker or assembler of a system basically faces two



alternatives to manage the development of its components. The development activities of a component can be either carried out in-house or outsourced. Depending on the proprietary sensitivity of the component and the degree of supplier involvement in design and manufacturing, the outsourced component can be further classified into three categories: supplier proprietary, detail controlled, and black box components. In addition, the supplier involvement in engineering can be characterized by the degree of functional specification and detailed engineering responsibilities carried out by the supplier (as shown in Figure 2).

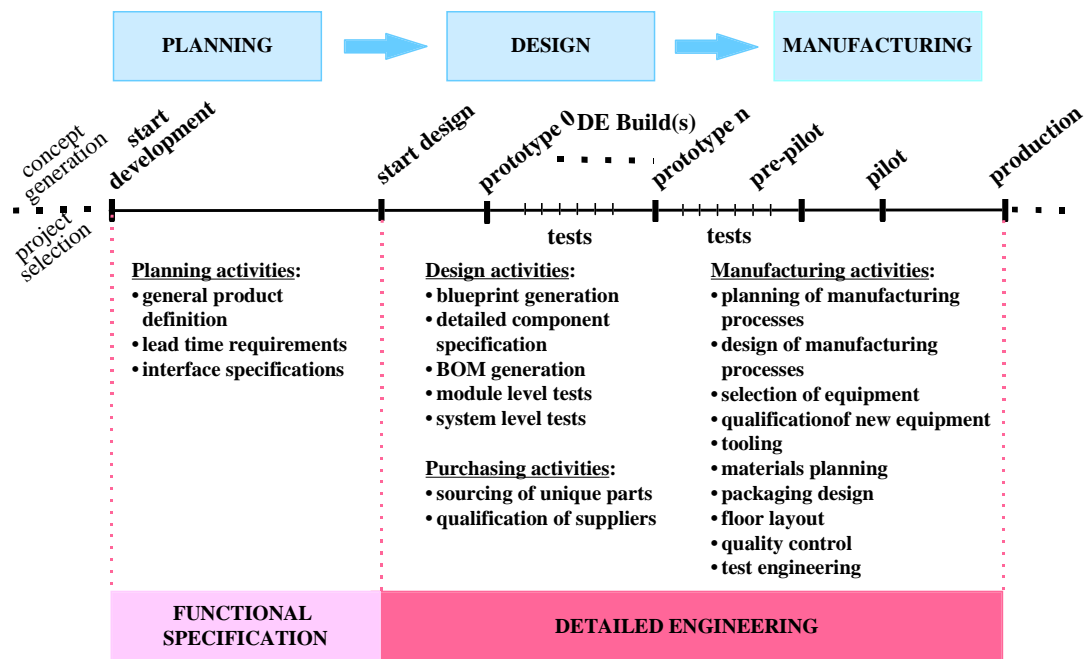

**Figure 1. New Product Development Activities**

*Supplier proprietary components* - Both functional specification and detailed engineering are performed by the supplier. There is almost no supplier involvement in the assembler's engineering decisions. The assembler (or buyer) can treat these components either as standard components (e.g., resistors, diodes, integrated circuits, etc.) or as highly customized parts (e.g., Intel microprocessors, digital signal processing chips, etc.).

*Detail controlled components*<sup>4</sup> - Both functional specification and detailed engineering are the responsibilities of the buyer. These components often are assembler's patented or proprietary parts. Build-to-print components fall into this category, in which case only the manufacturing activities are outsourced. The detail controlled components (such as microprocessors with proprietary software codes) and

<sup>4</sup> In Japan, detailed controlled component is referred to as 'design-supplied' part (Asanuma, 1985)

bill of materials (BOM) are often supplied and pre-defined by the assembler, making the supplier's involvement in the engineering activities limited. Some examples of detail controlled parts include mother-boards for computers, engine controllers, and some OEM goods.

*Black-box components*<sup>5</sup> - While the functional specification is set by the buyer, the detailed engineering responsibility lays completely in the hands of the supplier. Depending on the complexities of the component, the supplier's involvement in the assembler's engineering activities become more significant. The success (or failure) and added value provided by the of outsourcing of a black-box component is highly depended upon the willingness of the parties to share and collaborate in solving technical problems related to interface compatibility effects.

		<b>Detailed Engineering</b>	
		Supplier	Buyer/Assembler
Functional Specification	Supplier	<b>SUPPLIER PROPRIETARY COMPONENTS</b>	<b>“PARTNERSHIP” COMPONENTS</b>
	Buyer/ Assembler	<b>BLACK-BOX COMPONENTS</b>	<b>DETAIL CONTROLLED COMPONENTS</b>

**Figure 2. A Framework for Defining Supplier Involvement in Engineering.**

*“Partnership” components* - Due to the sequential nature of the NPD process (Figure 1), it is nearly unfeasible to have the functional specification of a component be defined by the supplier while the buyer is responsible for the detail engineering. This case may only be existent in Japanese practices where the operations and planning are highly integrated. For example, Toyota's and Nissan's suppliers invest in developing ideas and plans for the next model well in advance. Both the supplier and buyer engineers have long-term experience working together, making it easier to rapidly develop designs for the next model (Dyer and Ouchi, 1993).

<sup>5</sup> In Japan, black-box component is referred to as 'design-approved' part (Asanuma, 1985).

## 2.1 The Role of Modular Innovation in Black-Box Design

Henderson and Clark (1990) defined modular innovation as “an innovation that changes only the relationships between core design concepts of a technology. It is an innovation that changes a core design concept without changing the product’s architecture.” Similarly, Christensen and Rosenbloom (1995) described it as “the introduction of new component technology inserted within an essentially unchanged product architecture.” In general, product specifications of a black box is defined in advance by the buyer, enabling the product development activities to be carried out independently, thus not changing core design of the product architecture in which the black-box is intended for. Moreover, black-box designs often encompass some degree of innovation, thus changing the relationships between core design concepts of a technology. The modular innovation and its role in black-box design can be represented by Figure 3.

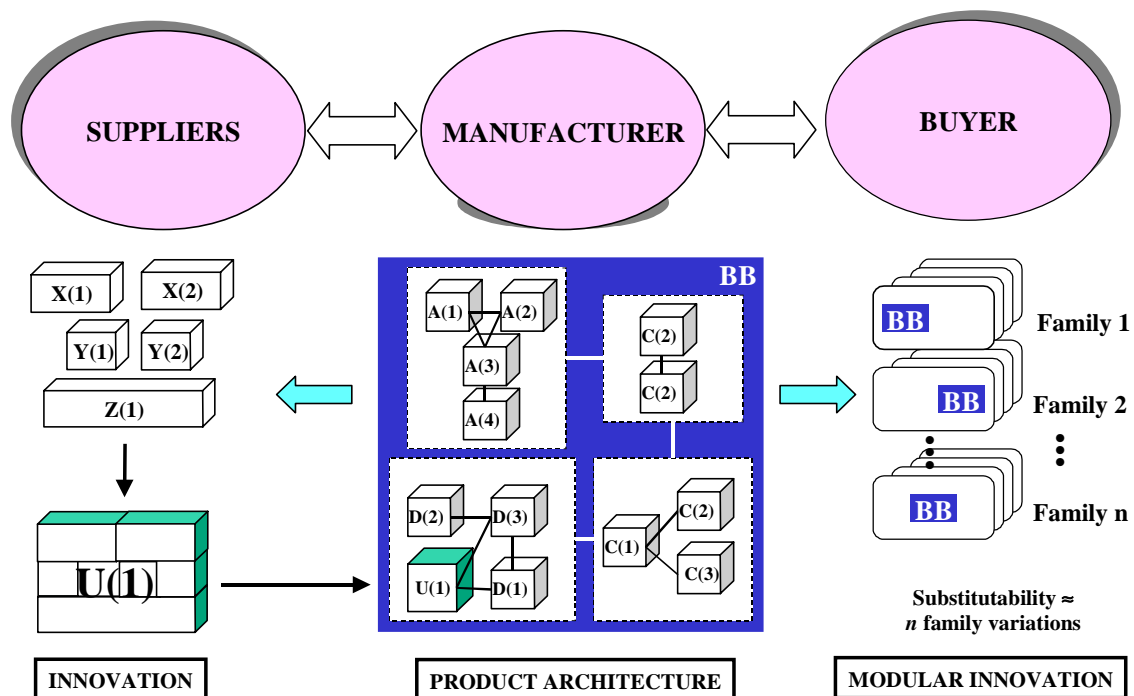

**Figure 3. Modular innovation and its role in black-box design.**

A black box has its unique product architecture that can be decomposed into sub-circuits, in which every component comprising the sub-circuit can be probed independently. Consider a manufacturer faced with the task of delivering a black-box component. Often the budget allocated to the project is limited with a very challenging detail engineering time table. This means that design lead time is compressed, hence not much room allocated for trial-and-error experiments to take place. Under such circumstances, the best solution is to produce the black box with as many standard components [e.g., A(n), B(n), C(n), and D(n)] as possible, thus lowering the component cost, manufacturing costs, and sourcing risks. The caution

here is that a black box developed solely with standard components can be easily copied and reverse-engineered by competitors. Thus, one solution is to design the black box with some specific state-of-the-art, proprietary technology [e.g.,  $U(1)$ ] so that its accessibility by competitors is limited, at least in the short-run. Although innovations within a black-box design are not obvious to the eyes of the buyer, the visible values are clearly indicated by the degree of substitutability of these modules. That is, the value of a black box is increased significantly as it can be inserted in families of products without changing the core concept and respective architectures. The substitutability factor can be represented by the number of  $n$  families of products enabled by a black box (BB). For example, black-box BB with innovation  $U(1)$  is a modular innovation that can be inserted in buyer's product architecture with  $n$  family of products.

Similarly, the manufacturer can also outsource some of its components as black-box parts to its suppliers, as in the case of  $U(1)$ . Such innovation or state-of-the-art technology is likely to be designed and manufactured by a supplier who possesses the specific knowledge and technical skills of the technology in question. Within the supplier's R&D organization, different sets of components and technologies [e.g.,  $X(n)$ ,  $Y(n)$ , and  $Z(n)$ ] are used in order to produce the innovation  $U(1)$ .

### **3. The Model**

A simple mathematical model is derived to explain the relationship between the degree of modularization in a given product architecture with respect to the composition of its components (e.g., number of NTF components), and degree of substitutability. The unit of analysis is a black box of which the functional specification (including planning activities) is set by the buyer and the detailed engineering (including design, purchasing, and manufacturing activities) is the responsibility of the supplier. The beauty of a mathematical model is that it allows us to synthesize a complex phenomenon into equations and functions, leading to a wide range of theoretical examinations and simulations of the phenomenon. Although mathematical models are powerful for analyzing dynamic behavior of the variables, it is confined to the limited number of variables and the formulation of the model is not so straightforward.

Product architecture defines the way in which components interact with each other. The substitutability factor of product architecture is a function of the number of product families made possible by the modular component as well as the number of interfaces required for functionality. For example, if a component of a given product architecture can be used in 10 families (or 10 times the same component), and 2 interfaces must be shared with other components/modules/sub-systems for functionality, then the substitutability factor of the product architecture is 5 components per interface. Modular product architecture is comprised of standard components with high substitutability, allowing for maximum opportunities for mixing-and-matching of components. Conversely, integral product architecture is comprised of NTF components with low substitutability, allowing for minimum opportunities for mixing-and-matching. A common product architecture that is used in various product families would have a high degree of substitutability, translating into high volume production. Hence it is assumed that the degree of modularization

in a given product architecture is constraint by the composition of its components (number of standard and NTF components), interfaces shared among the components, and degree of substitutability.

Standard components are components that are not new to the firm, often off-the-shelf parts, and have well defined technical specifications that are generally accepted as industry standards. These parts are often listed in catalogues with low unit prices varying accordingly with the volume purchased. NTF component, on the other hand, is a component that is usually considered as unique by a firm, as such components often have high technological risks by inducing changes at interfaces shared with other components, thus altering the configuration of a product architecture. Often the risks are well justified by the technical superiority of these components, significantly improving the overall performance of the product. The use of NTF components is strategic in nature because the integration of NTF components into a product architecture are often hard to be imitated by competitors (i.e., modular innovation), thus creating competitive advantages for the firm, at least in the short-run. But too many NTF components hamper innovation due to the increasing complexity in interface compatibility issues with other components in the product.

In order to capture the essence of modularity assessment, the following assumptions are made:

1. NPD of black box is used to demonstrate the modularization analysis. This implies that the product's functional specifications, including interface specifications, do not change over a period of time, allowing the evaluation of the architecture's configuration and components composition independently from other sub-systems.
2. A given product architecture is comprised of a combination of standard and NTF components.
3. It is argued that NTF components impose higher interface constraints in a given product architecture. Therefore, the lower the NTF components composition the higher the degree of modularization.
4. Product architectures made entirely of standard components can be equally damaging as product architectures with high-NTF-component content. It does not protect a product's technological content, and can be easily copied by the competitors. Thus, it is assumed that there should be some amount of NTF components in a black box.
5. All standard components are equally critical.
6. All NTF components are equally critical.
7. All interfaces<sup>6</sup> are equally critical.

---

<sup>6</sup> Interface is defined as the linkage between two components. Although one can further classify interfaces into attachment, spatial, transfer, control and communication, user, ambient, and environmental interfaces (Sanchez, 1999).

### 3.1 Assessment of Modularization in a Product Architecture of a Black-Box

The assessment of degree of modularization in a given product architecture involves the following steps:

1. Define product architecture and its boundaries.
2. Decompose the product architecture into sub-circuits, so that each one of the sub-circuits can be assessed individually.
3. Assess the substitutability factor of the black box by counting the number of product families enabled by the black box, divided by the number of interfaces required by the black box for functionality, in accordance with the level of analysis.
4. Count the total number of components comprising the product architecture. This can be accomplished by looking at the product's BOM.
5. Compute the NTF component composition of the product architecture (Equation 4.2).
6. Compute the interface constraint factor, or the average number of interfaces per component, for each sub-circuit as proposed in Section 4.3.
7. Plug these values into the modularization function (Equation 4.4) to find out the degree of modularization inherent in the product architecture.

### 3.2 Modularization Function Formulation

The modularization function indicates the amount of modularization inherent in a given product architecture. The amount of modularization is a function of the composition of NTF components, substitutability factor, and interface constraints. The modularization function,  $M(u)$ , decreases in a non-linear fashion from a perfect-modular architecture (i.e., no NTF components) to a perfect-integral architecture (i.e., no standard components).

$M(u)$ : Modularization function

$N$ : Total number of components

$n_{NTF}$  number of NTF components

$n_{standard}$  number of standard components

$$N = n_{NTF} + n_{standard} \quad \text{Equation 3.1}$$

$b$ : NTF components composition

$$b = \frac{n_{NTF}}{N} = \frac{u}{N} \quad ; \quad 0 \leq b \leq 1 \quad \text{Equation 3.2}$$

$b = 0$  represents a perfect-modular product architecture

$b = 1$  represents a perfect-integral product architecture

Given the range of component composition of a given product architecture defined by Equation 4.2, it is reasonable to assume that there is a relationship between modularization and the number of NTF components. In other words, it is expected that the degree of modularization,  $M$ , decreases at a rate,  $r$ , that is proportional to the amount of modularization present with each set of NTF components,  $u$ .

If  $M$  is amount of modularization present in a given product architecture with any set of NTF components  $u$ , then as the number of NTF components vary, the amount of modularization will have changed by the amount of  $\Delta M = rM$ . In other words, for any unit change of NTF components ( $\Delta u = 1$ ), the corresponding amount of modularization change  $\Delta M$  is proportional to the initial amount of modularization. From this, it seems plausible that a similar relation should hold for the decrease in any the amount of modularization in any set of NTF components; that is, the decrease of modularization should be proportional to the change in the number of NTF components as well as the initial amount of modularization.

$$\Delta M = (-rM)\Delta u \quad \text{or} \quad \frac{\Delta M}{\Delta u} = -rM$$

The factor  $r$  is the NTF component ratio per the total interface constraints in a given product architecture. Since a given product architecture may generate many family variations, the interface constraint factor is magnified by substitutability factor,  $s$ .

Thus, the factor  $r$  is represented as:

$$r = \frac{b}{s\delta} = \frac{u/N}{s\delta} \quad \text{Equation 3.3}$$

$s$ : substitutability factor

$\delta$ : interface constraint factor

Thus,

$$\Delta M = (-rM)\Delta u = \left( -\frac{u/N}{s\delta} \right) M\Delta u$$

In differential equation form,

$$\frac{dM}{du} = -\frac{u}{Ns\delta} M \quad \text{or} \quad \frac{dM}{M} = -\frac{u}{Ns\delta} du$$

For any constant  $r$ , the solutions to the above differential equation are of the form:

$$M(u) = M_0 e^{-u^2/2Ns\delta}$$

It is assumed that the amount of modularization is constraint by interface compatibility factors introduced by the NTF components in a given product architecture, thus the amount of modularization  $M$  in a perfect modular product architecture is when there are no NTF components ( $u=0$ ), hence the initial condition of  $M(0) = M_0 = 1.0$ .

Consequently, the modularization function is derived as the following:

$$M(u) = e^{-u^2/2Ns\delta} \quad \text{Equation 3.4}$$

### 3.3 Estimating the Interface Constraint Factor, $\delta$

Products are comprised of components, but hampered by the interface constraints shared among these components. Interface constraints are restrictions imposed by the components and how interfaces are shared amongst these components in a given product architecture. When a given product architecture is decomposed into sub-circuits, the interface constraints of these sub-circuits can be evaluated in stages. For example, the so called components of ‘closed assembled systems’<sup>7</sup> (e.g., cars, mobile phones, computers, etc.) can often be divided into two groups: electronic (e.g., resistors, capacitors, semiconductors, etc.) and mechanical (e.g., pins, nuts, bolts, housing, etc.). The circuit design (comprising of electronic components) of a given product architecture can often be evaluated in isolation from mechanical components, although interfaces shared with these components should not be neglected.

In this paper, interface constraints of a given product architecture is assessed in terms of the number of interfaces shared per component. For simplicity, the interface constraint factor  $\delta$  is approximated at two levels of analysis<sup>8</sup>. Level 1 analyzes the modularization of in the electronic portion of the product architecture (or the circuit design), and Level 2 analyzes the modularization of the circuit design in relation to mechanical portion of the product architecture.

**Level 1:** A given product architecture is decomposed into  $I$  number of sub-circuits so that components and respective interfaces can be analyzed individually at each sub-circuit levels. Then, an interface constraint value,  $\delta_c$ , defined as the number of interfaces per number of components in a sub-circuit, can be obtained:

---

<sup>7</sup> A ‘closed assemble system’ is a system that is enclosed by sub-systems with clear boundaries, and the individual sub-system must be linked together via interface and linkage technologies (Tushman and Rosenkopf, 1992).

<sup>8</sup> This type of analysis fits best for electrical products of which electronic and mechanical components are clearly delineated such as coffee machines, mobile phones, automotive components, personal computers, etc.



$$\delta_i = \frac{\sum k_c}{n_c}$$

- a) With  $I$  sub-circuits, the aggregate value of all interface constraints from sub-circuit components,  $\delta_{components}$ , is represented as the average of all  $\delta_i$ , that is,

$$\delta_{components} = \delta_{average} = \frac{\sum_{i=1}^I \delta_i}{I} \quad I = \text{number of sub-circuits}$$

So far we have evaluated interfaces of components *within* sub-circuits,  $\delta_c$ . The next step is to evaluate the interface constraints shared *among* the sub-circuits. That is, the interface constraint of sub-circuits,  $\delta_{sub-ckt}$ , is the number of interfaces shared by a sub-circuit ( $k_{sub-ckt}$ ) per the number of sub-circuits,  $I$ , or

$$\delta_{sub-ckt} = \frac{\sum k_{sub-ckt}}{I}$$

- b) The interface constraint factor of the electronic portion of the product architecture is, then, the sum of the interface constraints created by the components within the sub-circuits and interface constraint existent among the sub-circuits.

$$\delta_{level1} = \delta_{components} + \delta_{sub-ckt}$$

**Level 2:** The modularization of the mechanical portion of the product architecture is evaluated in the same manner as Level 1. In Level 2 analysis,  $\delta_{level1}$  is treated as an input to the final interface constraint factor calculation of the product architecture.

This algorithm is illustrated with the following analysis of two product architectures from Chrysler Jeep's windshield wipers controller.

#### 4. Case Illustration

In 1993, when Jeep Grand Cherokee was first introduced in the market as a high-end utility vehicle, a whole line of innovations and concepts were incorporated in it which were drastically different or not present in other Jeep models. Intermittent front-windshield wipers switch, WIPER controller, remote keyless entry, and vacuum fluorescent display monitor are some examples of electrical modules that were incorporated into the vehicle for the first time. These new innovations would provide significant improvement in performance, functionality and aesthetic looks compared to the existing Jeep models. In this case, the tasks and responsibility for the design and manufacturing of WIPER was outsourced to a world class manufacturer by Chrysler. The WIPER was considered a 'black-box' component because while the functional specification was Chrysler's responsibility, the detailed engineering including design and manufacturing was the responsibility of the supplier. Such activity resulted in two different technological solutions to the design of the module:

‘solid-state’ approach and ‘silent-relay’ approach<sup>9</sup>. The block diagram of the windshield wipers’ sub-system linkages is illustrated in Figure 4.

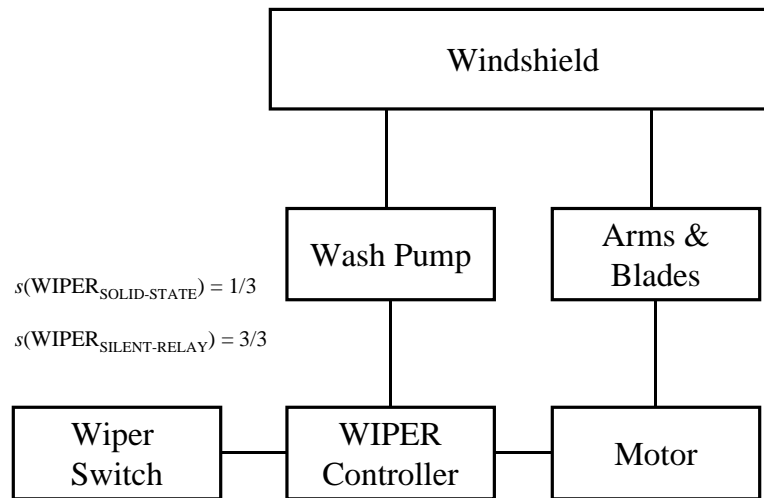
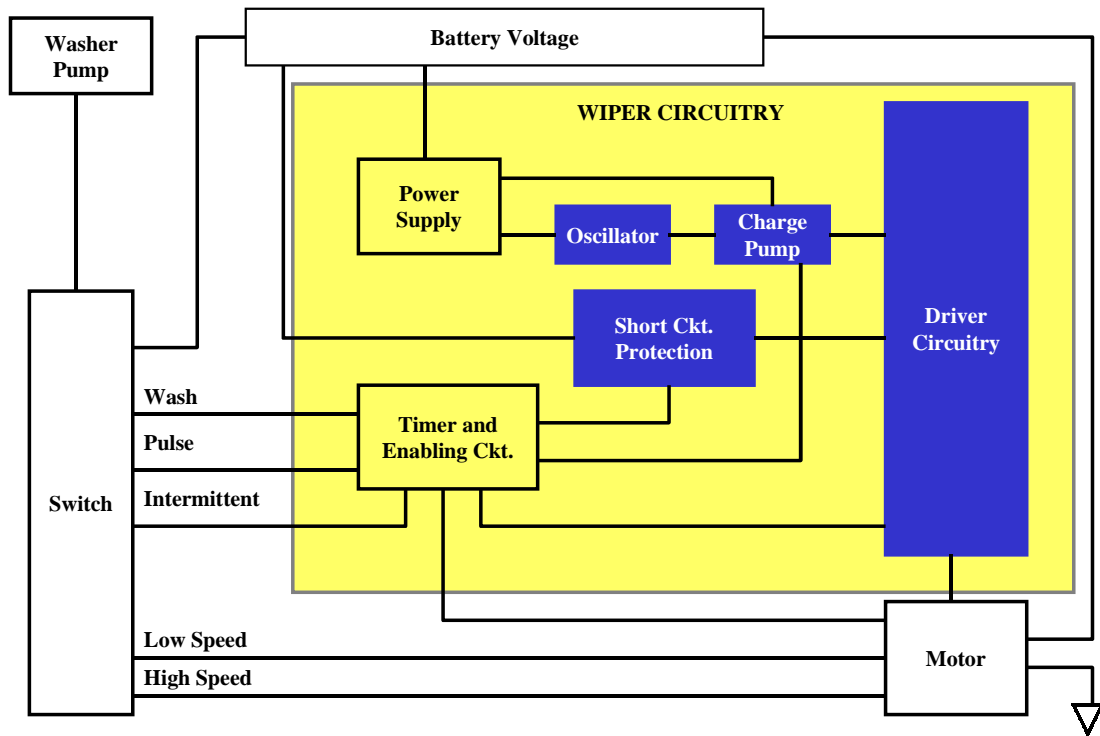

**Figure 4. Block diagram of windshield wipers system.**

The old WIPER controller modules applied standard-relay-based technology which made ‘clicking’ noises when switching from one state to another (e.g., ON and OFF), a very annoying feature to some customers. So one of the solutions to defeat such annoyance was to apply ‘solid-state’ technology of which only transistors and other electrical components are used to perform the task of ‘switching,’ thus virtually ‘soundless.’ The solid-state WIPER was eventually abandoned and considered a failure. But it was a caveat for the subsequent success of the silent-relay WIPER.

The WIPER module requires three linkages for functionality, regardless to the technologies embedded within the WIPER: wiper switch, wash pump, and motor. While the solid-state WIPER is only compatible with Grand Cherokee Jeeps (substitutability factor,  $s = 1/3 = 0,33$ ), all three families of Jeeps (Grand Cherokee, Cherokee, and Wrangler) can use the silent-relay WIPER ( $s = 3/3 = 1$ ). The product architectures of solid-state and silent-relay WIPERs are shown in Figure 5 and Figure 6 respectively.

<sup>9</sup> All the information presented in this study are the results of the author’s personal hands-on involvement in the product design, manufacturing, and sourcing tasks of the WIPER. The interpretation of the data are solely the responsibility of the author.



**Figure 5. Product architecture of solid-state WIPER.**

The product architecture of solid-state WIPER is consisted of the following sub-circuits: power supply, timer and enabling circuitry, oscillator, charge pump, short circuit protection, and driver circuitry. The product architecture of silent-relay WIPER replaces a portion of the solid-state WIPER, thus changing the relationships shared among the components and respective sub-circuits (Figure 5).

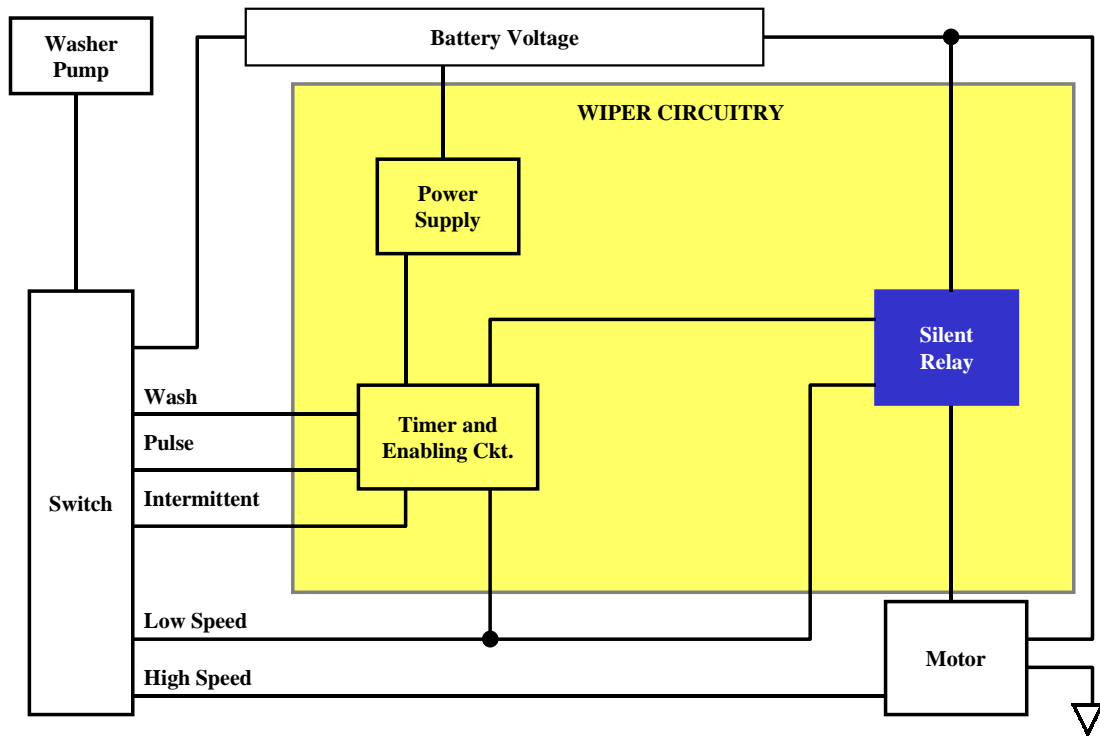

**Figure 6. Product architecture of silent-relay WIPER.**

Furthermore, the technical functionality of each sub-circuit is enabled by components and respective interfaces. For example, the power supply sub-circuit is comprised of three standard components (R1, C1 and VR1) and respective interfaces (Figure 7). Two connections or interfaces must exist for each one of these components. Moreover, the circuit must be configured in a specific way for the power supply circuit to deliver proper functionality. It is worth to mention that the configuration of such sub-circuit is considered a standardized design with high reusability across other circuit designs.

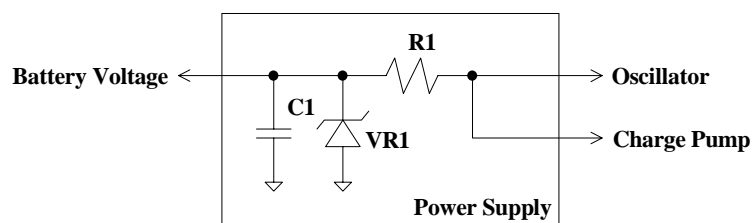

**Figure 7. Schematic of power supply circuit.**

The solid-state WIPER has 60 components ( $N=60$ ), of which 19 ( $u=19$ ) are NTF components, yielding a NTF component ratio  $b$  of 0,317 ( $b=19/60=0,317$ ). Similarly,

silent-relay WIPER has 57 components with 17 NTF components, translating to a value of 0,298 for  $b$ .

Following the algorithm described in Section 4.3, the calculations of interface constraint factors for both solid-state and silent-relay WIPERs are 9,85 and 9,94 respectively. Refer to Appendix A and B for the detailed calculations of the interface constraint factors,  $\delta_{solid-state}$  and  $\delta_{silent-relay}$ .

The electronic portion of the WIPER architecture (Level 1), for both the solid-state and silent-relay modules, share the following relationship with mechanical components (Level 2), as shown in Figure 8.

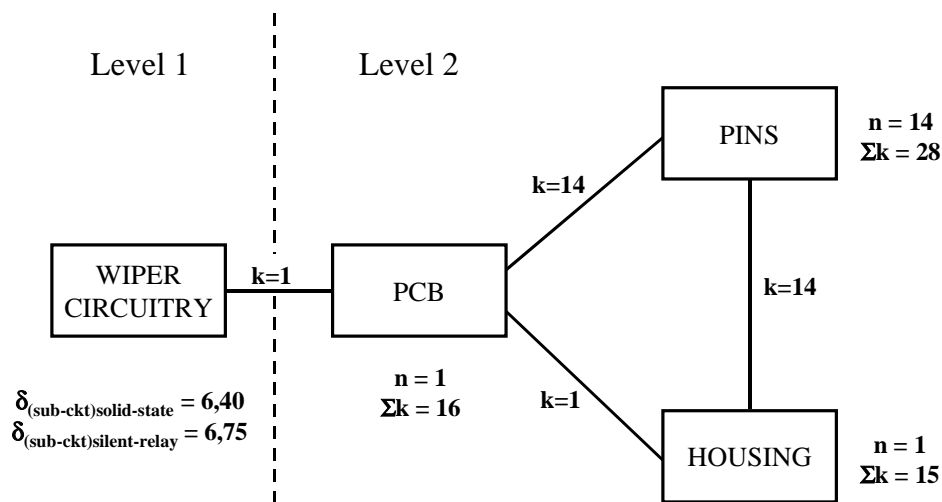

**Figure 8. WIPER's relationship with other components.**

Now that the interface constraint values have been estimated, we can plug these values into the modularization function,  $M(u) = e^{-u^2/2Ns\delta}$ :

SOLID-STATE WIPER

$$u = 19$$

$$N = 60$$

$$S = 0,33$$

$$\delta = 9,85$$

$$b = 0,317$$

$$M_{solid-state} = 0,40$$

SILENT-RELAY WIPER

$$u = 17$$

$$N = 57$$

$$S = 1,00$$

$$\delta = 9,94$$

$$b = 0,298$$

$$M_{silent-relay} = 0,77$$

The silent-relay WIPER has a higher degree of modularization ( $M_{\text{silent-relay}} = 0,77$ ) than the solid-state WIPER ( $M_{\text{solid-state}} = 0,4$ ). Given the relatively similar values of interface constraints, the main factor that made the silent-relay WIPER more modular is attributed to its higher substitutability factor and lower NTF component composition. Graphically, the modularization functions for both WIPERs are shown in Figure 9. Notice how the modularization gap increases as the number of NTF components increases.

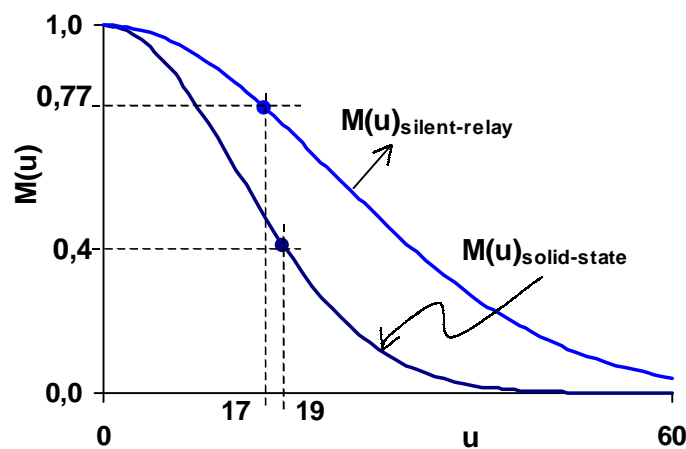

**Figure 9. Modularization functions for solid-state and silent-relay WIPERs.**

## 5. Conclusion

This paper discussed the concept of modularization as a new product development strategy at the detailed product design level. The unit of analysis is a black box of which the functional specification (including planning activities) is set by the buyer while the detailed engineering (including design, purchasing, and manufacturing activities) is the responsibility of the supplier. It was argued that systems are constrained by interface compatibility factors shared among the components. The complexity of the system is accentuated by the insertion of new-to-the-firm (NTF) components. Such components introduce uncertainties in the interface specification with respect to other components, hence reducing the opportunity for mixing-and-matching of components. Because each component has a specific function, modularization at the detailed product architecture level is not only about mixing-and-matching of these components but how these components are configured vis-à-vis other components in order to arrive at the desired performance. Hence, this paper focused on the evaluation of modularization in a given product architecture with

respect to the number of components and interfaces shared among these components as the determinant of the elementary complexity of the product architecture.

The main contribution of this paper lies with the derivation and application of a mathematical model in assessing modularization in a given product architecture. More specifically, the modularization function assesses modularization with respect to the NTF component composition, the degree of substitutability, and interface constraints. The function decreases in a non-linear fashion from a perfect-modular architecture (i.e., no NTF components) to a perfect-integral architecture (i.e., no standard components). The application of the modularization function was illustrated with a detailed product design of two product architectures of Chrysler Jeep's windshield wipers controllers. The case showed that although two product architectures may share similar interface constraints, but the opportunity for modularization of one module is significant higher than the other due to the higher substitutability of its components and lower composition of NTF components.

One of the advantages of a mathematical model is that it allows us to synthesize a complex phenomenon into equations and functions, leading to a wide range of theoretical examinations and simulations of the phenomenon. Although mathematical models are powerful for analyzing dynamic behavior of the variables, it is confined to the limited number of variables and the formulation of the model is not so straightforward. Certainly, there are other factors influencing the modularization in a given product architecture such as manufacturing capabilities, organizational designs, supplier-buyer partnerships, technological forecasting, to name a few. Moreover, different assessment methodologies may use different variables and analyze modularization from different perspectives, hence different results may be obtained and interpretation changed.

Despite the limitations set by the mathematical modeling approach a great deal can be learned about the intricacies shared among components and the interfaces linking them. This study should be extended to analyze the different types of interfaces, the tradeoff between modular and integral product architectures, the tradeoff between in-house versus outsourcing of components, the policy making of interface management, and the degree of integration versus decomposition of product architectures, for example.

## Appendix

### Appendix A. Interface Constraint Factor for solid state WIPER, $\delta_{solid-state}$ .

SOLID-STATE WIPER								
Component Level 1								
Sub-Circuit	Component	$k_c$	$\Sigma k_c$	$n_c$	$\delta_i = \frac{\Sigma k_c}{n_c}$	$k_{sub-ckt}$	$I$	$\delta_{sub-ckt} = \frac{\Sigma k_{sub-ckt}}{I}$
Power Supply	R1	2						
	VR1	2	6	3	2	3		
	C1	2						
Oscillator			16	4,50	3,56	2	6	3,83
Charge Pump			10	4,00	2,50	4		
Short Circuit			20	7,75	2,58	3		
Driver Circuit			16	7,00	2,29	4		
Enabling Circuit			44	17,75	2,48	7		
			$N_{electronic} = 44$					
			$\delta_{component} = \delta_{avg} =$		2,57			
			$\delta_{sub-ckt} =$					3,83
			$\delta_{level1} = \delta_{component} + \delta_{sub-ckt} =$					6,40
Component Level 2								
			k	n	$\delta$			
Sub-Circuit					6,40			
PCB			16	1	16			
Pins			28	14	2			
Housing			15	1	15			
			$N_{mechanical} = 16$					
			$N_{solid-state} = 60$					
			$\delta_{solid-state} = avg(\delta) =$		9,85			



**Appendix B. Interface Constraint Factor for Silent-Relay WIPER,  $\delta_{\text{silent-relay}}$ .**

SILENT-RELAY WIPER								
Component Level 1								
Sub-Circuit	Component	$k_c$	$\Sigma k_c$	$n_c$	$\delta_i = \frac{\Sigma k_c}{n_c}$	$k_{\text{sub-ckt}}$	$l$	$\delta_{\text{sub-ckt}} = \frac{\delta_i}{k_{\text{sub-ckt}} \cdot l}$
Power Supply	R1	2						
	VR1	2	6	3	2	3		
	C1	2					3	4,33
Timer & Enabling Circuit			79	35	2,26	6		
Silent Relay			9	3	3,00	4		
				$N_{\text{electronic}} =$	41			
				$\delta_{\text{component}} = \text{avg}(\delta_c) =$	2,42			
				$\delta_{\text{sub-ckt}} =$		4,33		
				$\delta_{\text{level1}} = \delta_{\text{component}} + \delta_{\text{sub-ckt}} =$		6,75		
Component Level 2								
		k	n	$\delta$				
Sub-Circuit				6,75				
PCB		16	1	16				
Pins		28	14	2				
Housing		15	1	15				
				$N_{\text{mechanical}} =$	16			
				$N_{\text{silent-relay}} =$	57			
				$\delta_{\text{solid-state}} = \text{avg}(\delta) =$	9,94			

## REFERENCES

- Asanuma, B. (1985) The Contractual framework for parts supply in the Japanese automotive industry, *Japanese Economics Studies*, (Summer), 55-78.
- Baldwin, C.Y. and Clark, K.B. (1997) Managing in an Age of Modularity. *Harvard Business Review*, (September-October), 84-93.
- Baldwin, C.Y. and Clark, K.B. (1994) Modularity in design: An analysis based on the theory of real options. *Working paper 93-026*, Harvard Business School.
- Bowersox, D.J. (1982) Emerging from the recession: the role of the distribution manager. *Focus*, **1**, 2, (Jul-Aug).
- Christensen, C.M. and Rosenbloom, R.S. (1995) Explaining the attacker's advantage: technological paradigms, organizational dynamics, and the value network. *Research Policy*, **24**, 233-257.
- Clark, K.B. (1985) The interaction of design hierarchies and market concepts in technological evolution. *Research Policy*, **14**, 235-251.
- Clark, K.B. (1989) Project Scope and Project Performance: The Effect of Parts Strategy and Supplier Involvement on Product Development. *Management Science*, **35**, 10, 1247-1263.
- Dyer, J.H. and Ouchi, W.G. (1993) Japanese Style Business Partnerships: Giving Companies a Competitive Edge. *Sloan Management Review*, (Fall), 51-63.
- Feitzinger, E. and Lee, H.L. (1997) Mass customization at Hewlett-Packard: the power of postponement. *Harvard Business Review*, (Jan-Feb), 116-121.
- Gilmore, J.H. and Pine, B.J. (1997) The Four Faces of Mass Customization. *Harvard Business Review*, (Jan-Feb), 91-101.
- Henderson, R.M. and Clark, K.B. (1990) Architectural Innovation: The Reconfiguration of Existing Product Technologies and the Failure of Established Firms. *Administrative Science Quarterly*, **35**, 9-30.
- Hsuan, J. (1999a) Impacts of supplier-buyer relationships on modularization in new product development. *European Journal of Purchasing and Supply Management*, **5**, 3/4, 197-209.
- Hsuan, J. (1999b) Modularization in New Product Development: A Mathematical Modeling Approach. *Copenhagen Business School Working Paper 99-4*, June.
- Kotha, S. (1995) Mass Customization: Implementing the Emerging Paradigm for Competitive Advantage. *Strategic Management Journal*, **16**, 21-42.
- Langlois, R.N. and Robertson, P.L. (1992) Networks and innovation in a modular system: Lessons from the microcomputer and stereo component industries. *Research Policy*, **21**, 297-313.

- Lucas, Henry C. (1997) *Information Technology for Management*. 6<sup>th</sup> edition, The McGraw-Hill Companies, Inc.
- Lundqvist, M., Sundgren, N. and Trygg, L. (1996). Remodularization of a Product Line: Adding Complexity to Project Management. *Journal of Product Innovations Management*, **13**, 311-324.
- Meyer, M.H. and Utterback, J.M. (1993) The Product Family and the Dynamics of Core Capability. *Sloan Management Review*, (Spring), 29-47.
- Periasamy, K. Kelly and Feeney, David F. (1997) Information Architecture Practice: Research-based Recommendations for the Practitioner, in *Managing IT as a Strategic Resource*, Willcocks et al. (eds), McGraw-Hill Publishing Company, pp. 341-359.
- Pine, J. (1993) *Mass Customization – The New Frontier in Business Competition*. Boston, MA: Harvard Business School Press.
- Sanchez, R. (1994) Modularity in Product, Process and Knowledge Architectures: Foundations for a New Management Framework. Executive seminar presentation, Copenhagen Business School, October 14.
- Sanchez, R. (1994) Towards a Science of Strategic Product Design: System Design, Component Modularity, and Product Leveraging Strategies. University of Illinois at *Urbana-Champaign Working Paper No. 94-0124*.
- Sanchez, R. and Mahoney, J.T. (1996) Modularity, Flexibility, and Knowledge Management in Product and Organisation Design. *Strategic Management Journal*, **17**, (Winter Special Issue), 63-76.
- Schaefer. S. (1999) Product design partitions with complementary components. *Journal of Economic Behavior & Organization*, **38**, 311-330.
- Shirley, G.V. (1990) Models for managing the redesign and manufacture of product sets. *Journal of Manufacturing and Operations Management*, **3**, 2, 85-104.
- Tushman, M.L. and Rosenkopf, L. (1992) Organizational determinants of technological change: toward a sociology of technological evolution. *Research in Organizational Behavior*, JAI Press, Greenwich, CT, 311-347.
- Ulrich, K. (1995) The role of product architecture in the manufacturing firm. *Research Policy*, **24**, 419-440.
- Ulrich, K. T. and Eppinger, S. (1995). *Product Design and Development*. New York, NY: McGraw-Hill.

# Danish Research Unit for Industrial Dynamics

## *The Research Programme*

The DRUID-research programme is organised in 3 different research themes:

- *The firm as a learning organisation*
- *Competence building and inter-firm dynamics*
- *The learning economy and the competitiveness of systems of innovation*

In each of the three areas there is one strategic theoretical and one central empirical and policy oriented orientation.

### ***Theme A: The firm as a learning organisation***

The theoretical perspective confronts and combines the resource-based view (Penrose, 1959) with recent approaches where the focus is on learning and the dynamic capabilities of the firm (Dosi, Teece and Winter, 1992). The aim of this theoretical work is to develop an analytical understanding of the firm as a learning organisation.

The empirical and policy issues relate to the nexus technology, productivity, organisational change and human resources. More insight in the dynamic interplay between these factors at the level of the firm is crucial to understand international differences in performance at the macro level in terms of economic growth and employment.

### ***Theme B: Competence building and inter-firm dynamics***

The theoretical perspective relates to the dynamics of the inter-firm division of labour and the formation of network relationships between firms. An attempt will be made to develop evolutionary models with Schumpeterian innovations as the motor driving a Marshallian evolution of the division of labour.

The empirical and policy issues relate the formation of knowledge-intensive regional and sectoral networks of firms to competitiveness and structural change. Data on the structure of production will be combined with indicators of knowledge and learning. IO-matrixes which include flows of knowledge and new technologies will be developed and supplemented by data from case-studies and questionnaires.

### ***Theme C: The learning economy and the competitiveness of systems of innovation.***

The third theme aims at a stronger conceptual and theoretical base for new concepts such as 'systems of innovation' and 'the learning economy' and to link these concepts to the ecological dimension. The focus is on the interaction between institutional and technical change in a specified geographical space. An attempt will be made to synthesise theories of economic development emphasising the role of science based-sectors with those emphasising learning-by-producing and the growing knowledge-intensity of all economic activities.

The main empirical and policy issues are related to changes in the local dimensions of innovation and learning. What remains of the relative autonomy of national systems of innovation? Is there a tendency towards convergence or divergence in the specialisation in trade, production, innovation and in the knowledge base itself when we compare regions and nations?

#### **The Ph.D.-programme**

There are at present more than 10 Ph.D.-students working in close connection to the DRUID research programme. DRUID organises regularly specific Ph.D.-activities such as workshops, seminars and courses, often in a co-operation with other Danish or international institutes. Also important is the role of DRUID as an environment which stimulates the Ph.D.-students to become creative and effective. This involves several elements:

- access to the international network in the form of visiting fellows and visits at the sister institutions
- participation in research projects
- access to supervision of theses
- access to databases

Each year DRUID welcomes a limited number of foreign Ph.D.-students who want to work on subjects and projects close to the core of the DRUID-research programme.

#### **External projects**

DRUID-members are involved in projects with external support. One major project which covers several of the elements of the research programme is DISKO; a comparative analysis of the Danish Innovation System; and there are several projects involving international co-operation within EU's 4th Framework Programme. DRUID is open to host other projects as far as they fall within its research profile. Special attention is given to the communication of research results from such projects to a wide set of social actors and policy makers.

## DRUID Working Papers

- 96-1 **Lundvall, Bengt-Åke:** The Social Dimension of the Learning Economy. (ISBN 87-7873-000-7)
- 96-2 **Foss, Nicolai J.:** Firms, Incomplete Contracts and Organizational Learning. (ISBN 87-7873-001-5)
- 96-3 **Dalum, Bent and Villumsen, Gert:** Are OECD Export Specialisation Patterns 'Sticky?' Relations to the Convergence-Divergence Debate. (ISBN 87-7873-002-3)
- 96-4 **Foss, Nicolai J.:** Austrian and Post-Marshallian Economics: The Bridging Work of George Richardson. (ISBN 87-7873-003-1)
- 96-5 **Andersen, Esben S., Jensen, Anne K., Madsen, Lars and Jørgensen, Martin:** The Nelson and Winter Models Revisited: Prototypes for Computer-Based Reconstruction of Schumpeterian Competition. (ISBN 87-7873-005-8)
- 96-6 **Maskell, Peter:** Learning in the village economy of Denmark. The role of institutions and policy in sustaining competitiveness. (ISBN 87-7873-006-6)
- 96-7 **Foss, Nicolai J. & Christensen, Jens Frøslev:** A Process Approach to Corporate Coherence. (ISBN 87-7873-007-4)
- 96-8 **Foss, Nicolai J.:** Capabilities and the Theory of the Firm. (ISBN 87-7873-008-2)
- 96-9 **Foss, Kirsten:** A transaction cost perspective on the influence of standards on product development: Examples from the fruit and vegetable market. (ISBN 87-7873-009-0)
- 96-10 **Richardson, George B.:** Competition, Innovation and Increasing Returns. (ISBN 87-7873-010-4)
- 96-11 **Maskell, Peter:** Localised low-tech learning in the furniture industry. (ISBN 87-7873-011-2)
- 96-12 **Laursen, Keld:** The Impact of Technological Opportunity on the Dynamics of Trade Performance. (ISBN 87-7873-012-0)
- 96-13 **Andersen, Esben S.:** The Evolution of an Industrial Sector with a Varying Degree of Roundaboutness of Production. (ISBN 87-7873-013-9)

- 96-14 **Dalum, Bent, Laursen, Keld & Villumsen, Gert:** The Long Term Development of OECD Export Specialisation Patterns: De-specialisation and “Stickiness”. (ISBN 87-7873-014-7)
- 96-15 **Foss, Nicolai J.:** Thorstein B. Veblen: Precursor of the Competence-Based Approach to the Firm. (ISBN 87-7873-015-5)
- 96-16 **Gjerding, Allan Næs:** Organisational innovation in the Danish private business sector. (ISBN 87-7873-016-3)
- 96-17 **Lund, Reinhard & Gjerding, Allan Næs:** The flexible company Innovation, work organisation and human ressource management. (ISBN 87-7873-017-1)
- 97-1 **Foss, Nicolai J.:** The Resource-Based Perspective: An Assessment and Diagnosis of Problems. (ISBN 87-7873-019-8)
- 97-2 **Langlois, Richard N. & Foss, Nicolai J.:** Capabilities and Governance: the Rebirth of Production in the Theory of Economic Organization. (ISBN 87-7873-020-1)
- 97-3 **Ernst, Dieter:** Partners for the China Circle? The Asian Production Networks of Japanese Electronics Firms. (ISBN 87-7873-022-8)
- 97-4 **Richardson, George B.:** Economic Analysis, Public Policy and the Software Industry. (ISBN 87-7873-023-6)
- 97-5 **Borrus, Michael & Zysman, John:** You Don’t Have to Be A Giant: How The Changing Terms of Competition in Global Markets are Creating New Possibilities For Danish Companies. (ISBN 87-7873-024-4)
- 97-6 **Teubal, Morris.:** Restructuring and Embeddeness of Business Enterprises- Towards an Innovation System Perspective on Diffusion Policy. (ISBN 87-7873-025-2)
- 97-7 **Ernst, Dieter & Guerrieri, Paolo:** International Production Networks and Changing Trade Patterns in East Asia: The case of the Electronics Industry. (ISBN 87-7873-026-0)
- 97-8 **Lazaric, Nathalie & Marengo, Luigi:** Towards a Characterisation of Assets and Knowledge Created in Technological Agreements: Some evidence from the automobile-robotics sector. (ISBN 87-7873-027-9)

- 97-9 **Ernst, Dieter.:** High-Tech Competition Puzzles. How Globalization Affects Firm Behavior and Market Structure in the Electronics Industry. (ISBN 87-7873-028-7)
- 97-10 **Foss, Nicolai J.:** Equilibrium vs Evolution in the Resource-Based Perspective: The Conflicting Legacies of Demsetz and Penrose. (ISBN 87-7873-029-5)
- 97-11 **Foss, Nicolai J.:** Incomplete Contracts and Economic Organisation: Brian Loasby and the Theory of the firm. (ISBN 87-7873-030-9)
- 97-12 **Ernst, Dieter & Lundvall, Bengt-Åke:** Information Technology in The Learning Economy – Challenges for Developing Countries. (ISBN 87-7873-031-7)
- 97-13 **Kristensen, Frank Skov (p):** A study of four organisations in different competitive environments. (ISBN 87-7873-032-5)
- 97-14 **Drejer, Ina, (p) Kristensen, Frank Skov (p) & Laursen, Keld (p):** Studies of Clusters as a Basis for Industrial and Technology Policy in the Danish Economy. (ISBN 87-7873-033-3)
- 97-15 **Laursen, Keld (p) & Drejer, Ina (p):** Do Inter-sectoral Linkages Matter for International Export Specialisation? (ISBN 87-7873-034-1)
- 97-16 **Lundvall, Bengt-Åke & Kristensen, Frank Skov (p):** Organisational change, innovation and human resource Development as a response to increased competition. (ISBN 87-7873-036-8)
- 98-1 **Præst, Mette (p):** An Empirical Model of Firm Behaviour: A dynamic Approach to Competence Accumulation and Strategic Behaviour. (ISBN 87-7873-037-6)
- 98-2 **Ducatel, Ken:** Learning and skills in the Knowledge Economy. (ISBN 87-7873-038-4)
- 98-3 **Ernst, Dieter:** What Permits Small Firms to Compete in High-Tech Industries? Inter-Organizational Knowledge Creation in the Taiwanese Computer Industry. (ISBN 87-7873-039-2)
- 98-4 **Christensen, Jens Frøslev:** The Dynamics of the Diversified Corporation and the Role of Central Management of Technology. (ISBN 87-7873-040-6)
- 98-5 **Valente, Marco (p):** Laboratory for Simulation Development. (ISBN 87-7873-041-4)



- 98-6 **Valente, Marco (p):** Technological Competition: a Qualitative Product Life Cycle. (ISBN 87-7873-042-2)
- 98-7 **Lam, Alice:** The Social Embeddedness of Knowledge: Problems of Knowledge Sharing and Organisational Learning in International High-Technology Ventures. (ISBN 87-7873-043-0)
- 98-8 **Jørgensen, Kenneth M. (p):** Information Technology and Change in Danish Organizations. (ISBN 87-7873-044-9)
- 98-9 **Andersen, Esben Sloth:** Escaping Satiation in an Evolutionary Model of Structural economic Dynamics. (ISBN 87-7873-045-7)
- 98-10 **Foss, Kirsten:** Technological Interdependencies, Specialization and Coordination: A Property Rights Perspective on The Nature of the Firm. (ISBN 87-7873-046-5)
- 98-11 **Andersen, Poul H:** Organizing International Technological Collaboration in Subcontractor Relationships. An Investigation of the Knowledge-Stickyness Problem. (ISBN 87-7873-047-3)
- 98-12 **Nymark, Søren (p):** Billeder af strategi i forandringsrige organisatoriske omgivelser: 3 cases fra DISKO studierne. (ISBN 87-7873-048-1)
- 98-13 **Andersen, Esben Sloth:** The Evolution of the Organisation of Industry. (ISBN 87-7873-050-3)
- 98-14 **Foss, Kirsten & Foss, Nicolai J.:** The Market Process and The Firm: Toward a Dynamic Property Rights Perspective. (ISBN 87-7873-051-1)
- 98-15 **Lorenz, Edward:** Societal Effects and the Transfer of Business Practices to Britain and France. (ISBN 87-7873-053-8)
- 98-16 **Ernst, Dieter:** Catching-Up, Crisis and Industrial Upgrading. Evolutionary Aspects of Technological Learning in Korea's Electronics Industry. (ISBN 87-7873-054-6)
- 98-17 **Kaisla, Jukka (p):** The Market Process and the Emergence of the Firm: Some Indications of Entrepreneurship Under Genuine Uncertainty. (ISBN 87-7873-055-4)
- 98-18 **Laursen, Keld (p):** Do Export and Technological Specialisation Patterns Co-evolve in Terms of Convergence or Divergence?: Evidence from 19 OECD Countries, 1971-1991. (ISBN 87-7873-056-2)
- 98-19 **Foss, Nicolai J.:** Firms and the Coordination of Knowledge: Some Austrian Insights. (ISBN 87-7873-057-0)
- 98-20 **Mahnke, Volker (p) & Aadne, John Harald:** Process of Strategic Renewal, Competencies, and the Management of Speed. (ISBN 87-7873-058-9)

- 98-21 **Lorenzen, Mark (p):** Information, cost learning, and trust. Lessons form co-operation and higher-order capabilities amongst geographically proximate firms. (ISBN 87-7873-059-7)
- 98-22 **Lam, Alice:** Tacit Knowledge, Organisational Learning and Innovation: A Societal Perspective. (ISBN 87-7873-060-0)
- 98-23 **Lund, Reinhard:** Organizational and innovative flexibility mechanisms and their impact upon organizational effectiveness. (ISBN 87-7873-061-9)
- 98-24 **Christensen, Jesper Lindgaard & Drejer, Ina (p):** Finance and Innovation System or Chaos. (ISBN 87-7873-062-7)
- 98-25 **Laursen, Keld (p):** How Structural Change Differs, and Why it Matters (for Economic Growth) (ISBN 87-7873-063-5)
- 98-26 **Holmén, Magnus & Jacobsson, Staffan:** A method for identifying actors in a knowledge based cluser. (ISBN 87-7873-064-3)
- 98-27 **Richardson, G. B.:** Production, Planning and Prices. (ISBN 87-7873-065-1)
- 98-28 **Foss, Nicolai J.:** Austrian Economics and Game Theory: a Preliminary Methodological Stocktaking. (ISBN 87-7873-067-8)
- 98-29 **Foss, Nicolai J. & Mahnke, Volker (p):** Strategy Research and the Market Process Perspective. (ISBN 87-7873-068-6)
- 98-30 **Laursen, Keld (p):** Revealed Comparative Advantage and the Alternatives as Measures of International Specialisation. (ISBN 87-7873-069-4)
- 99-1 **Lorenz, E.:** Organisationaal Innovation, Governance Structure and Innovative Capacity In British and French Industry. (ISBN 87-7873-070-8)
- 99-2 **Ernst, Dieter:** Responses to the Crisis: Constraints to a Rapid Trade Adjustment in East Asia's Electronics Industry. (ISBN 87-7873-071-6)
- 99-3 **Foss, N. J. :** Understanding Leadership: A Coordination Theory. (ISBN 87-7873-072-4)
- 99-4 **Foss, K & Foss, N. J:** Understanding Ownership: Residual Rights of Control and Appropriable Control Rights. ( ISBN 87-7873-073-2)
- 99-5 **Foss, K & Foss, N. J:** Organizing Economic Experiments: The role of Firms. (ISBN 87-7873-075-9)
- 99-6 **Jørgensen Kenneth. M. (p) :** The Meaning og Local Knowledges. (ISBN 87-7873-076-7)

- 99-7 **Foss, N. J.:** Capabilities, Confusion, and the Costs of Coordination: On Some Problems in Recent Research On Inter-Firm Relations. (ISBN87-7873-077-5)
- 99-8 **Lund, Reinhard:** Tillidsrepræsentantsystemet og de fleksiblevirksomhedsformer. Juli 1999. (ISBN887-7873-078-3)
- 99-9 **Nymark, Søren:** Organisatorisk læring gennem den værdibaserede organisations fortællinger. (ISBN 87-7873-079-1)
- 99-10 **Laursen, K. & Meliciani, V.:** The importance of technology based inter-sectoral linkages for market share dynamics. (ISBN 87-7873-080-5)
- 99-11 **Laursen, K., Mahnke, V., Vejrup-Hansen, P.:** Firm growth from a knowledge structure perspective. ( ISBN 87-7873-081-3)
- 99-12 **Lundvall, Bengt-Åke, Christensen, Jesper. L.:** Extending and Deepening the Analysis of Innovation Systems - with Emperical Illustrations from the DISCO-project. (ISBN 87-7873-082-1)
- 00-1 **Llerena, Patrick & Oltra, Vanessa:** Diversity of innovative strategy as a source technological performance. (ISBN 87-7873-085-6)
- 00-2 **Llerena, Patrick & Mireille Matt:** Technology policy and cooperation: A paradigmatic approach. (ISBN 87-7873-086-4)
- 00-3 **Cusmano, Lucia:** Technology Policy and Co-operative R&D: the role of relational research capacity. (ISBN 87-7873-087-2)
- 00-4 **Mikkola, Juliana Hsuan:** Modularization assessment of product architecture. (ISBN87-7873-088-0)

### **Information for subscribers.**

Subscription price for 1997 is 600 DKr (about 20 papers). The rate for single issues is 40 DKr. It is possible to make a commitment to an exchange of papers from related departments or research teams. All correspondence concerning the DRUID Working Papers should be send to.

Jonna Jacobsen  
 Fibigerstræde 4  
 DK-9220 Aalborg OE  
 Tel. 45 96 35 82 65  
 Fax. 45 98 15 60 13

