

MOISTURE CONTENT EFFECT ON TENSILE PROPERTIES OF INDIVIDUAL DOUGLAS-FIR LATEWOOD TRACHEIDS¹

Paul C. Kersavage

School of Forest Resources, The Pennsylvania State University, University Park, PA 16802

(Received 8 January 1973)

ABSTRACT

A testing system was developed to determine tensile properties of single wood fibers under precisely controlled relative humidity conditions. Individual delignified Douglas-fir summerwood tracheids were tested axially in tension at moisture contents of 0, 6, 12, 18% and in a water-soaked condition. Load-elongation curves were predominantly linear to failure and curve shape was unaffected by moisture content, implying that stresses in tracheids were borne primarily by a structural framework with a high degree of crystallinity. Moisture content significantly affected tracheid tensile properties. Tracheids tested wet exhibited the lowest strength and elasticity. The overall relationship between strength properties and moisture was curvilinear with maxima in tensile strength and modulus of elasticity at about 12 and 6% moisture content, respectively. Tensile strengths obtained were higher than published values for other cellulosic fibers. Maximum internal stresses on the cellulosic framework of tracheids were considered to approach those theoretically calculated for cellulose chain scission, suggesting highly crystalline microfibrils containing an extended-chain crystal lattice structure.

Additional keywords: *Pseudotsuga menziesii*, tension tests, fiber strength, stress-strain curve.

INTRODUCTION

Although there have been an increased number of studies during the past decade on the tensile properties of individual wood fibers, many aspects of their mechanical behavior are still not understood. Investigations have been for the most part unrelated, and many different methods of preparing and testing fibers have been employed. This disparateness, coupled with a frequent lack of discussion of previous findings, has led, in many cases, to a clouding of basic relationships. This seems particularly true regarding the effect moisture has on tracheid tensile strength properties. Comparatively little work has been done on this subject and the results obtained have been conflictive. Some investigators have indicated that wood fibers have higher dry than wet strengths (Klauditz et al. 1947; Russel et al. 1964; Kallmes and

Perez 1966), whereas others have indicated the opposite (Wardrop 1951; Leopold and Thorpe 1968). In addition, only two moisture conditions were used in these studies—wet and dry (room conditions). The anomalies and cursory nature of these studies indicated a need for further research.

The primary purpose of this study was to investigate how the static tensile stress-strain relationship of Douglas-fir summerwood tracheids is influenced by quantitative variations in moisture content. In order to cover the complete range of fiber moisture conditions, nominal moisture contents selected were 0, 6, 12, 18, and 30% (wet or water-saturated).

EXPERIMENTAL PROCEDURE

Preparation and selection of test specimens

To ensure a homogeneous tracheid sample, all test specimens were prepared from the summerwood portion of a single growth ring from a 100-mm-thick disc of Douglas-fir (*Pseudotsuga menziesii*). Summerwood from the 32nd growth ring was split into

¹Condensed version of paper that received honorable mention in the 1972 Wood Award competition. Authorized for publication as paper No. 4351 in the journal series of the Pennsylvania Agricultural Experiment Station.

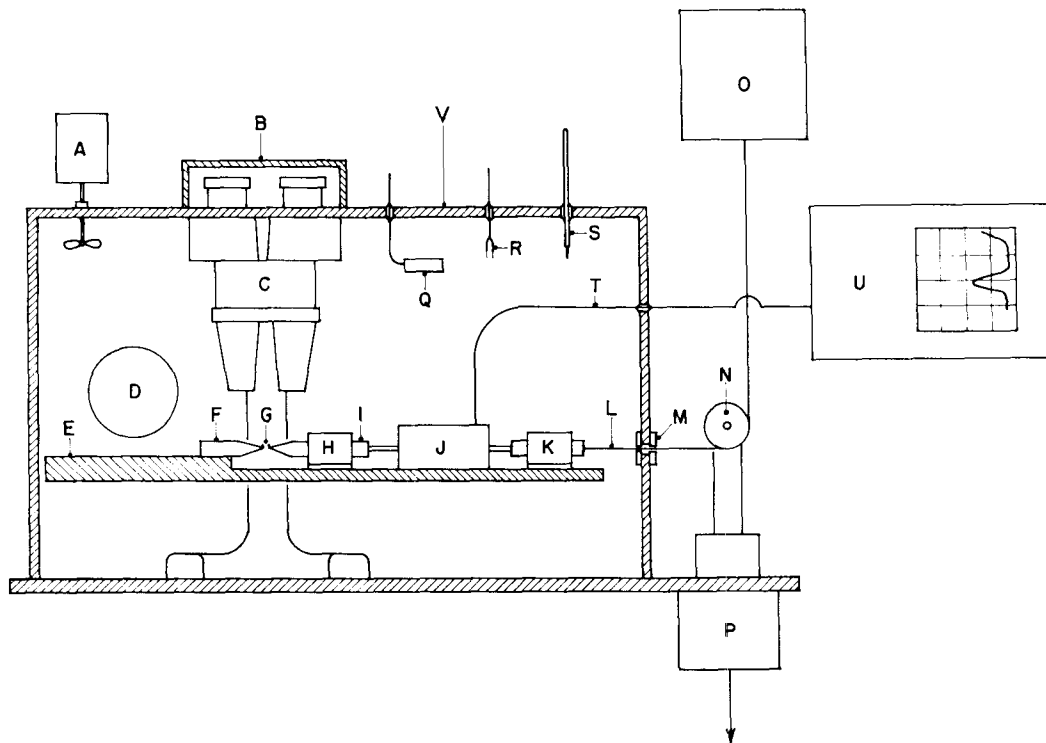

FIG. 1. Schematic diagram of tensile testing system. Salient features include mercury scaled fan (A), viewing box (B), stereoscopic microscope (C), chamber entry portal (D), plastic base plate (E), stationary and movable tensile grips (F & I), fiber grips (G), ball bushing (H, K), linear transducer (J), load transmitting filament (L), mercury seal (M), low friction pulley (N), load cell (O), universal testing machine movable crosshead (P), humidity sensor (Q), thermocouple (R), thermometer (S), transducer wiring (T), load-elongation recorder (U), and conditioning chamber (V).

chips approximately 3 mm square in cross section and 25 mm long, using a microtome knife. Delignification was accomplished using a chlorite holocellulose method similar to the one described by Jayne (1959). Browning (1967) indicated that chlorite holocellulose contains from 2 to 4% lignin with some loss of hemicellulose ($\frac{1}{2}$ to 2%). A small sample of delignified chips subjected to a procedure similar to TAPPI Standard T 13 M-54 (1954), indicated that delignified tracheids contained 2 to 3% lignin. The average yield of the delignification treatment was found to be 72%.

The single-tracheid test specimens were selected from dilute slurries of fibers using a stereoscopic microscope. Specimens were handled only at terminal areas using jeweler's tweezers and were examined at a

magnification of 40 \times for evidence of damage. Test specimens were randomly selected from a population of fibers greater than 2.5 mm in length, the minimum required for subsequent tensile test preparation.

Tensile testing system

In order to accomplish the objectives of this study, it was necessary to develop an accurate and precise means of measuring the axial tensile properties of single wood fibers under carefully controlled and extremely varied relative humidity conditions. Some of the problems involved in tensile testing of single wood fibers are well validated in the literature as recently reviewed by Duncker and Nordman (1968) and Page et al. (1972). The tensile testing sys-

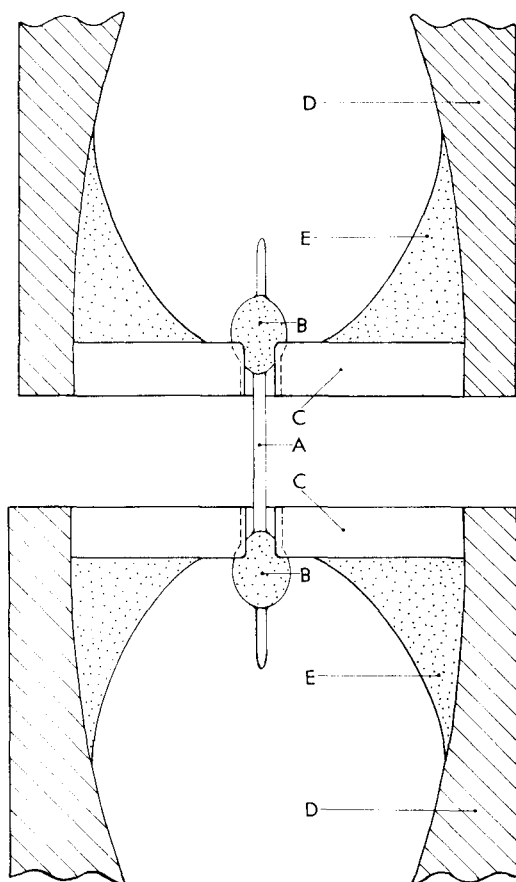

FIG. 2. Schematic of portion of gripping system illustrating manner in which tracheid test specimen (A) was gripped during tensile test. Epoxy droplets (B) attached near specimen ends formed ball-type joints with stainless steel fiber grips (C) bonded to brass tensile grips (D) with structural epoxy adhesive (E).

tem used in this study was designed and built to eliminate or minimize some of the concomitant difficulties that have been encountered. It employs a gripping method designed for self-alignment of the test specimen, thus reducing the possibility of major stress concentration. The gripping method in conjunction with a horizontal testing scheme minimizes the risk of handling damage. The accuracy of deformation data is increased by placing an elongation-measurement device in close proximity to the test specimen. In addition, testing was accomplished under very stable and uni-

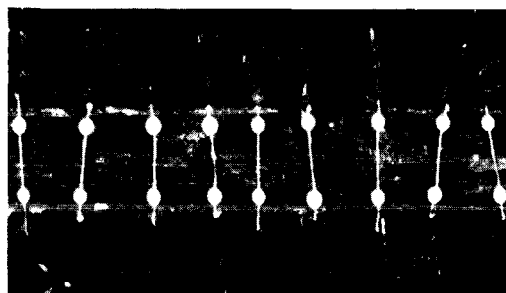

FIG. 3. Single-tracheid test specimens, with epoxy droplets near tracheid ends, secured across channel on plastic platform. 4 \times .

form temperatures and relative humidities even at extreme conditions.

The complete tensile testing system is schematically illustrated in Fig. 1. A fiber test is conducted by inserting the specimen into the fiber grips (G) and lowering the crosshead (P) of the testing machine. As the crosshead is lowered, a horizontal force is transmitted through the system to the fiber and to the load cell (O) by the load transmitting filament (L). The load cell and linear transducer, connected to a recording system (U), permit a continuous record of the load-elongation curve for each test under precisely controlled environmental conditions.

Reproducibility of the testing system, based on confidence-limit determinations, was considered good in view of the biological nature and minute size of the test specimens. Testing of fibers in groups of 24 to 49 was sufficient to set fiducial limits on the mean strength and elastic modulus of ± 6 -16% at the 95% confidence level.

Gripping and preparing single tracheids for testing

The method of gripping tracheids during testing was similar to that used by Kersavage (1962) and Schiewind (1966). Test specimens were not gripped directly but by means of small oval-shaped epoxy droplets affixed near the terminal portions of each specimen. When the specimen was placed into the grips and force applied, the epoxy droplets and the grips formed two miniature ball-type joints, thereby loading

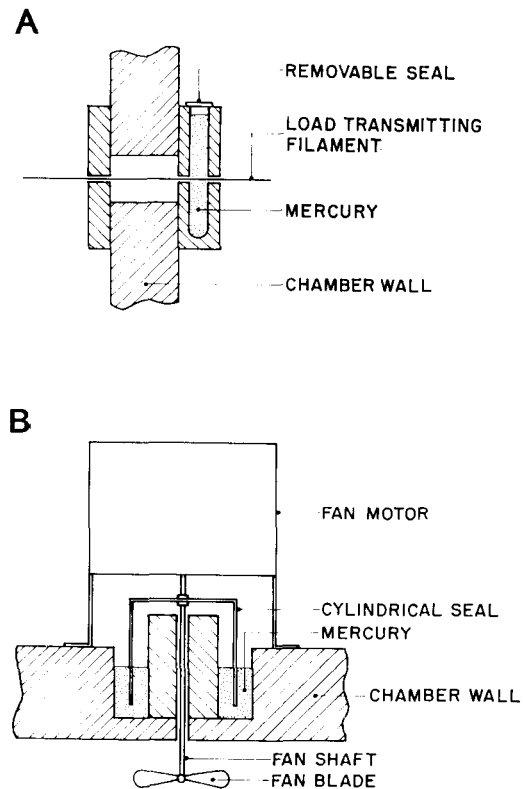

FIG. 4. Air-tight mercury-sealed joint (A), for load transmitting filament, and similar type joint (B), for air movement apparatus of environmental control chamber.

the specimen axially in tension. A fiber grip consisted of a slotted stainless steel disc with a minute center hole. Semispherical grooves around each center hole were designed to aid in fiber self-alignment, thereby reducing conventional tendencies for stress concentration at the grips. A structural epoxy adhesive was used to glue the stainless steel grips to brass tubing, filed to points to facilitate fiber insertion into the grips (Fig. 2).

The first step in preparing single tracheids for tensile testing was to secure wet specimens across channels machined onto Plexiglas platforms. Double-coated plastic tape on each side of the channel held the specimens in place during drying and subsequent gluing operations. Minute globules of a freshly mixed epoxy adhesive (3M Scotch-Weld EC-1838 B/A) applied near

TABLE 1. Average internal chamber conditions and specimen moisture contents.

Conditioning Mechanism	Temp. ^a (C)	Relative Humidity ^b (%)	Moisture Content ^c (%)	
			Nominal	Actual
Phosphorus Pentoxide Powder (P_2O_5)	22	1	0	0.8
Room Conditions	22	29	6	6.0
Sodium Nitrate Crystal ($NaNO_2$)	22	66	12	12.1
Potassium Bisulfate Crystal ($KHSO_4$) ^d	22	83	18	17.7
Water Soak	22	100	30	wet ^e

^a Estimated average value obtained from recorded data (range of $\pm 1^\circ C$)

^b Estimated average value obtained from recorded data (range of $\pm 1\% RH$)

^c Average value based on three moisture content samples.

^d Also included in the chamber were two small pans of water.

^e Moisture content was not determined.

the ends of each specimen formed oval-shaped droplets completely surrounding the fiber surface (Fig. 3). The droplets would harden in the same shape since very little shrinkage occurs during the epoxy curing reaction. Specimen gage length, defined as the distance between epoxy droplets, was measured using a stereoscopic microscope equipped with a filar micrometer eyepiece and averaged 1.7 mm.

Environmental control chamber and specimen conditioning

The airtight environmental control chamber was constructed of $\frac{1}{4}$ -inch Plexiglas, and various types of epoxy adhesives and caulking compounds were used to seal chamber joints and holes made for installation of permanent equipment. A removable access panel to the chamber was bolted with wing nuts and sealed with a vaseline-like silicone lubricant. With the access panel in place, a rubber glove, secured to the chamber entry portal, afforded access

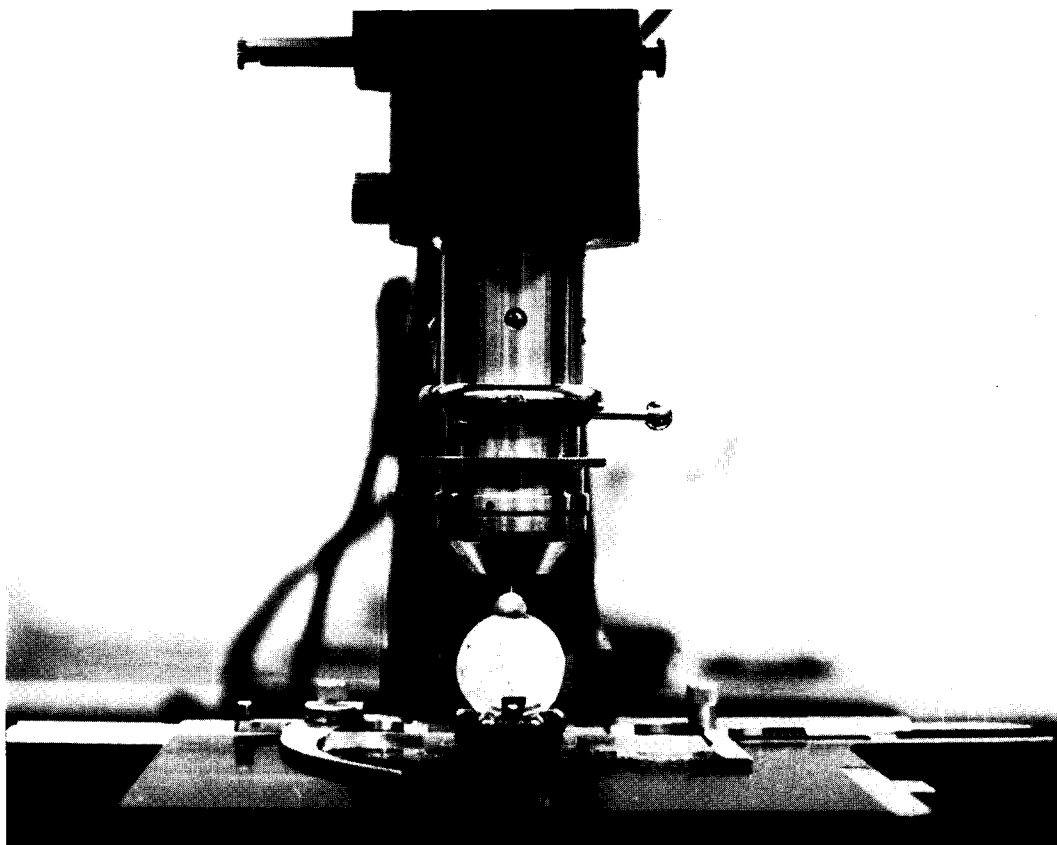

FIG. 5. Ultrapak objective and micromanipulator used in cross-sectional area measurements of single wood tracheids.

to the test specimens within the chamber. Airtight mercury-sealed joints shown in Fig. 4 allowed the apparatus to function normally while at the same time permitting tensile tests to be conducted in a closed system of precisely controlled atmosphere.

The required internal chamber test conditions were obtained and maintained through the use of dry chemical solids shown in Table 1 and the thermostatically controlled temperature conditioning system of the testing room. All of the specimens except those tested wet were conditioned a minimum of one week before testing. The wet tests were accomplished by wetting each test specimen just prior to testing. The water formed into a small drop between the two grips, completely engulfing the test specimens. After a 1-min

soaking, the test was conducted while the fiber was immersed in water.

A continuous recording of temperature and relative humidity within the environmental chamber was obtained using a copper-constantan thermocouple and an electrical humidity sensor (Hygrosensor), wired into a two-channel millivolt recorder. Temperature and relative humidity could be measured to the nearest 0.1 C and 0.5%, respectively.

Estimates of the average moisture content (moisture expressed as a percentage of oven-dry weight) for each of the test conditions except wet were obtained from representative moisture content samples contained in glass weighing bottles, using the oven-drying method described by Browning (1967). The nominal moisture

content for the wet specimens was assumed to be 30%. While it is recognized that the actual wet moisture contents would be considerably greater for the delignified fibers in view of the findings of Stone and Scallan (1967), earlier work has shown that mechanical properties of woody, lignified tissue do not tend to change with moisture content above the 30% level.

Measurement of load-elongation

Load-elongation measurements were made on a universal testing machine (Tinius Olsen 1000-lb capacity XY Electromatic LoCap) equipped to produce load-elongation curves. The machine was also fitted with a sensitive load cell capable of measuring breaking loads from 0 to 250 g with an accuracy of ± 0.3 g. The test specimens were elongated at a rate of 0.1 mm per minute (0.6 mm/mm/min). Elongation measurements were made using a linear voltage differential transformer. With it, elongations up to 2.50 mm long could be made with an accuracy of ± 0.002 mm. Deformation in the tensile grips and epoxy droplets was found to be negligible under expected load ranges.

Cross-sectional area measurements

The method developed to obtain cross-sectional area involved the direct observation and photographing of fiber cross sections, using a Leitz Ortholux microscope equipped with a 50 \times Ultropak objective, 10 \times Periplan eyepiece, and a Leica 35-mm camera body. A compensating planimeter was used to measure cross-sectional area from the photomicrographic prints. The method did not require any embedding, thereby eliminating a major source of error and difficulty in previous experiments (Hardacker 1969).

Prior to photomicrographing, each test specimen was sliced with a single-edged razor perpendicular to its long axis near the point of failure. The sliced specimen was then secured, by means of the epoxy droplet, to a micromanipulator consisting of a glass sphere seated in a ball bushing fastened to a glass slide (Fig. 5). A small

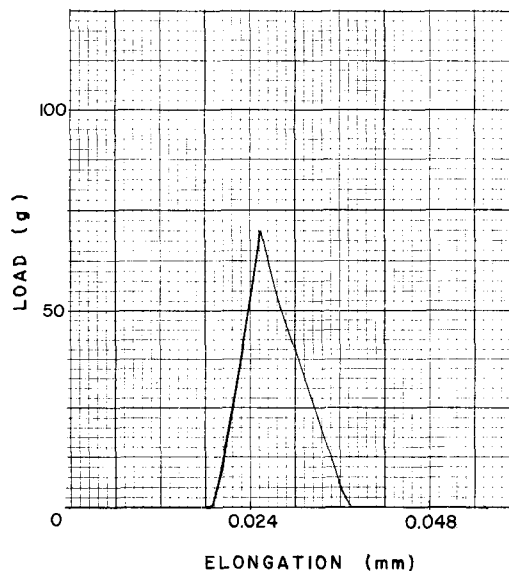

FIG. 6. Copy of actual load-elongation curve typifying most frequently encountered curve shape.

quantity of modeling clay fixed atop the sphere kept the fiber in place. The sphere could be rotated in any direction, while the slide, fitted onto the microscope object holder, could be moved horizontally and vertically by the microscope mechanical stage. This allowed easy positioning of the specimen and facilitated critical focusing of the cross section.

RESULTS AND DISCUSSION

Load-elongation curves

Most specimens tested, regardless of moisture content, exhibited linear load-elongation curves of the type shown in Fig. 6. They are characterized initially by a slightly concave upward curvature for a short distance followed by a linear or Hookean portion until failure. Similar types of curves have been noted in the literature as being predominant for wood fibers (Hartler et al. 1963; Duncker and Nordman 1965; Tamolang et al. 1967; Smith and Morton 1968; McIntosh and Uhrig 1968; Leopold and Thorpe 1968). Linear curves were also reported by Jentzen (1964) and Kallmes and Perz (1966) for fibers dried without restraint, but they found curvi-

TABLE 2. Average tensile properties and coefficients of variation for single delignified Douglas-fir summerwood tracheids at each level of nominal moisture content.

Property	Statistical Parameter	Nominal Per Cent Moisture Content				
		0	6	12	18	30(wet)
Breaking Load (g)	Avg. ^a	38.2 C ^a	46.7 B	61.4 A	51.8 B	30.0 D
	C.V. ^b	(38.9)	(37.2)	(23.7)	(24.6)	(42.2)
Cross-sectional area (μm^2)	Avg.	447 C	494 BC	486 BC	524 AB	576 A
	C.V.	(21.7)	(23.0)	(20.6)	(21.3)	(28.9)
Tensile Strength (kg/mm^2)	Avg.	87.0 C	95.5 BC	128.3 A	99.8 B	53.4 D
	C.V.	(38.9)	(34.7)	(24.5)	(23.2)	(42.9)
Modulus of Elasticity (kg/mm^2)	Avg.	2840 AB	3040 A	2890 AB	2700 B	1580 C
	C.V.	(32.6)	(22.8)	(18.7)	(25.9)	(39.7)
Number of Fibers Tested		24	45	41	49	30

^aMeans followed by same letter are not significantly different from each other. Based on multiple comparison of study variable means using Duncan's (Bayesian) least significant difference test computed with minimum-average-risk $T=1.7698$ for $K=100$ (alpha approximately equal to 0.05).

^bPer cent coefficient of variation in parentheses.

linearity (concave downward) in the terminal portions of the curves for fibers dried in tension. Jayne (1959) reported that this latter type of curve was predominant, although his fibers were not dried in tension. Hardacker (1962) found curves that were extremely variable in shape, ranging from strictly linear to complex curvilinear types. Dumbleton (1972) found that negatively straining fibers resulted in sigmoidally shaped curves. Similar curve shapes were reported by Page et al. (1972) for fibers buckling prior to failure; otherwise substantially linear curves were found.

Most of these findings have indicated that wood fibers stressed axially in tension exhibit essentially linear load-elongation curves and that the curve shape is relatively independent of most factors, such as delignification, species, and moisture content.

The Hookean type load-elongation curves obtained in this study at various moisture contents raised the question whether the testing system masked some curvilinearity that may have been present and whether it was sensitive enough to detect subtle changes in stress-strain relationships such as yield point and regions of flow. To

check this hypothesis, tests were conducted on individual wool and rayon fibers—materials that are known to exhibit plastic deformation. The load-elongation curves that were obtained had shapes similar to published curves for these fibers and contained excellent examples of linear or Hookean regions, proportional limit, and complex curvilinearity in the regions of plastic flow. These findings suggest that the tensile system used in this study validly depicts the shape of load-elongation curves.

Sensitivity of tracheid tensile properties to moisture content

The tensile property results are summarized in Table 2. An analysis of variance revealed that the moisture content treatment of the test specimens significantly (0.1% levels) affected their tensile properties. One of the most notable effects occurred as the result of wetting the specimens and testing them in a saturated condition. The wet specimens in comparison to any of the dry specimens, whether tested at 0, 6, 12, or 18% MC conditions, had considerably lower breaking loads, tensile strength, and Young's moduli. A multiple comparison test (Table 2) indicated that

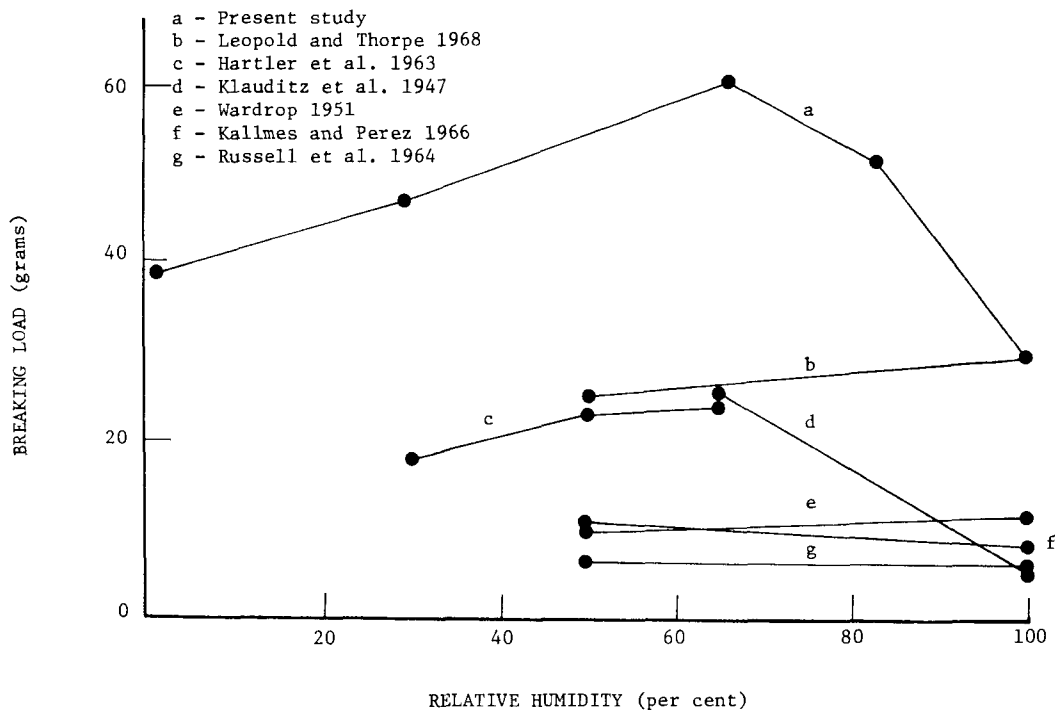

FIG. 7. Comparison of results from studies reporting on the relationship between breaking load of individual pulped-wood tracheids and relative humidity.

these differences were statistically significant (approximately 5% level).

The reduction in breaking and tensile strength upon wetting was qualitatively similar to findings of Klauditz et al. (1947); Russel et al. (1964); and Kallmes and Perez (1966) for pulped wood tracheids. It was in contrast, however, to the results of Wardrop (1951) for earlywood tracheids and Leopold and Thorpe (1968) for latewood tracheids, who found higher breaking loads in the wet condition. The different strength-moisture relationship found in these studies are graphically illustrated in Fig. 7.

The reason for these differences is not entirely clear. Higher wet strength of cotton fibers was explained over 40 years ago on the basis that wetting allowed a more uniform stress distribution, thereby resulting in an increase in breaking strength (Brown et al. 1930). Wardrop (1951) and Leopold and Thorpe (1968) explained their higher wet strength for pulped wood fibers

in a similar manner. On the other hand, the higher dry strength of pulp tracheids tested by Klauditz et al. was explained on the basis of a closer contact of cellular constituents upon drying. They felt that the remaining cellulose and hemicellulose took up spaces left by desolubilized components, causing the formation of a more strongly bonded and denser cell wall, with a resultant strengthening of tracheid cohesiveness and strength.

It is difficult to reconcile all of the data on dry and wet strength differences and to form a generalized statement regarding the effect of wetting on pulped wood tracheids. A possible explanation of this anomaly, especially in view of the wide variety of experimental conditions associated with each of these studies, is that the conflicting findings may have been the result of some experimental factor. For example, Negishi (1946, 1947) found that fibers dried under tension no longer exhibited differences be-

tween dry and wet strength. The fact that Klauditz et al. found that drying and re-wetting resulted in an increase in wet strength (5.3 to 10.8 g) is additional evidence that pretreatment of fibers can affect their strength.

The possibility that low wet strengths in this experiment were induced by some facet of the testing method was seriously considered. This hypothesis was checked using cotton fibers and reasoning as follows. If the test method itself caused a lower wet strength, it would be likely to do so on other fibers as well. Consequently, cotton fibers, which are known to be stronger or at least as strong in the wet condition as in the dry (Meredith 1956), were tested in the dry and wet state using the same methods employed in this study. Practically all cotton fibers tested wet had higher breaking loads and the average breaking load was higher for the wet cotton fibers (7.8 as compared to 4.3 g), which was similar to results found in the literature. On this basis, it was concluded that the testing method itself was not the likely cause of the lower wet strength values found in this study.

If the wet strength results of this study are valid estimates and not artifacts, what then is the explanation of the lower wet strength values? It apparently is not due only to loss of lignin since both lignified and delignified tracheids have exhibited lower wet strengths (Kersavage 1971; details of findings on lignified tracheids will be published later). These results suggest that the reason for lower wet strengths may be associated with a factor common to each of the specimens—the holocellulose or carbohydrate portion of the cell wall, regardless of the presence of lignin. This is surprising in view of the findings that certain native cellulose fibers with little or no lignin such as cotton, ramie, and flax have somewhat higher wet than dry strengths (Meredith 1956). However, these non-woody fibers consist primarily of cellulose and contain very little hemicellulose, suggesting that the relatively larger amount of hemicellulose contained in the test speci-

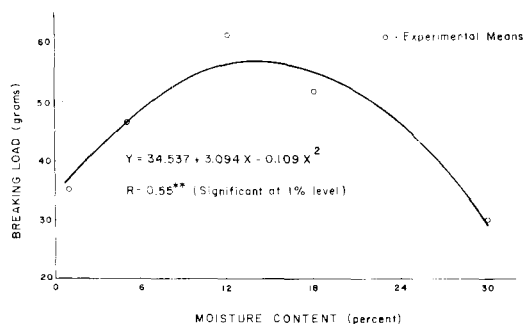

FIG. 8. Regression curve showing relationship between breaking load and moisture content.

mens of this study may be a key factor in the differential effect of wetting.

On the basis of these observations, it is interesting to speculate as to the mechanisms by which cellulosic fiber tensile strength is affected by moisture. Higher wet strengths of fibers with high cellulose but low hemicellulose content, such as cotton, might be explained on the basis of the behavior of cell-wall constituents as they dry. Since it is known that cellulose becomes increasingly brittle as it dries (Hermans 1949), it is conceivable that in drying it also becomes increasingly susceptible to the development of strength-reducing flaws, thereby resulting in a fiber that is stronger wet than dry. The holocellulose in wood fibers is probably affected in a similar manner with changes in moisture except that at the higher moisture levels, and especially at saturation, the hygroscopic hemicellulose may become especially plastic and weak (Clark 1969), resulting in a weaker overall bonding between cellulose structural units, and therefore a fiber with lower wet than dry strength.

Mechanisms similar to those discussed above conceivably could have led to the curvilinear relationships between tracheid moisture content and breaking load and tensile strength as shown in Figs. 8 and 9. As the tracheid dries initially, the hemicellulose becomes less plastic and the overall bonding between the carbohydrates becomes stronger, resulting in an increase in strength. As drying continues, cell-wall

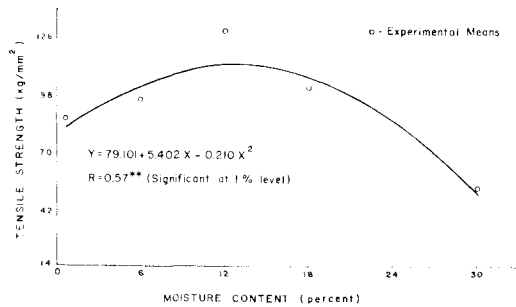

FIG. 9. Regression curve showing relationship between tensile strength and moisture.

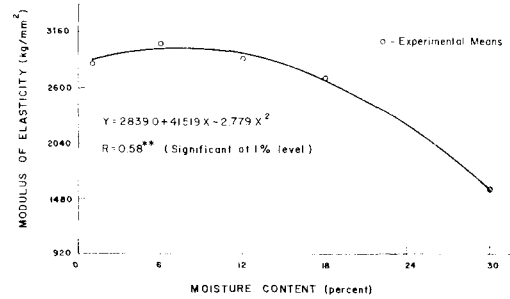

FIG. 10. Regression curve showing relationship between modulus of elasticity and moisture content.

shrinkage and densification continues and the carbohydrates—the cellulose in particular—start becoming inflexible and brittle, and consequently more susceptible to the development of microchecks and other flaws, and therefore progressively weaker. Apparently, a point is reached at which the weakening of cellulose because of its increased brittleness and the strengthening of hemicellulose because of its reduced plasticity result in an optimum in tracheid strength. An optimum for this study occurred at a relative humidity of about 60 to 70%. This is also the relative humidity range where increases in strength of cotton fibers with increases in moisture begin to level off, and also where rayon fibers begin to decrease in strength at a much higher rate (Wakeham 1954; Meredith 1956). This latter behavior is how hemicellulose in the experimental tracheids may have reacted.

Curvilinear relationships between moisture content and tensile strength properties similar to those found in this study have also been reported for wood (Kollmann 1951; Ifju 1964), paper (Brecht 1962; Broughton 1967), and jute fibers (Zylinski 1958).

Wetting also caused a considerable and significant decrease in modulus of elasticity (MOE) of the specimens tested in this study. These findings are in agreement with the results of similar experiments on wood fibers (Russel et al. 1964; Kallmes and Perez 1966) and textile fibers of various types (Meyer and Lotmar 1936; Meredith 1956; Wakeham 1954). This effect could

be considered ubiquitous for cellulosic fibers, since no contradictions could be found in the literature.

The reduction in MOE on wetting can be explained primarily on the basis that in the swollen condition there is a reduction in cell-wall cohesiveness or in the bonding between cellulosic fibrils and within other cellulosic substances. This explanation is consistent with the concept that layers or clusters of water molecules sorbed onto intracellular surfaces act as a lubricant resulting in an overall slippage between fibrils upon stress (Ifju 1964).

Over the total range of moisture content conditions, the MOE of test specimens exhibited a tendency to increase as they were dried from saturation, reaching an optimum at about 6% MC (25 to 30% RH). Below this moisture level, the MOE decreased slightly with decreases in MC (Fig. 10). Similar relationships for wood have been reported (Kollmann and Krech 1960; Kadita et al. 1961).

The basic reason for the decrease in MOE of the experimental tracheids at the lower moisture levels may be associated with changes in the matrix responsible for redistributing applied loads to the structural load-bearing cellulose. As the matrix becomes dry, it becomes increasingly inflexible and therefore less efficient in transmitting stresses to the structural phase of the tracheid two-phase system. At these dry levels, the matrix bears a greater portion of the external loads, and because of

TABLE 3. Comparison of average tensile properties of individual Douglas-fir fibers from present study with published data.

Researcher and Year of Study	Tensile Data ^a										
	FT ^b	MOI ^c	GL (mm)	T (C)	RH (%)	BL (g)	CSA (μm^2)	TS ₂ (kg/mm ²)	MOE ₂ (kg/mm ²)	STRAIN (%)	N
Van den Akker et al. (1958)		KR		23	50	17.4	272	63.9			103
Jayne (1959)	L	CH	2.5	22	50		516	99.7	4464	2.4	7-10
Kersavage (1962)	L	CH	2.8	19	65	37.6	619	63.0			10
Dinwoodie (1965)		KR		20 ^d	65 ^d			43.6			50 ^d
Schniewind (1966)	L	CH		21	65	60.4	627	96.1			
Kersavage (Present Study)	L	CH	1.6	24	63	61.4	486	128.2	2883	4.5	41

^aFT - Fiber type, MOI - Method of isolation, GL - Gage length, T - Temperature, RH - Relative humidity, BL - Breaking load, CSA - Cross-sectional area, TS - Tensile strength, MOE - Modulus of elasticity, STRAIN - Ultimate strain, N - Number of specimens tested.

^bL - Latewood.

^cKR - Kraft, CH - Chlorite holocellulose.

^dFrom Dinwoodie 1973, personal communication.

its relatively lower modulus (Mark 1967) results in a greater tracheid elongation per unit of stress and a concomitant lowering of the tracheid's MOE.

Evaluation of experimental results

Table 3 compares the results with those of other studies in which Douglas-fir tracheids have been tested. It shows that the average breaking load and tensile strength of tracheids tested at 12% moisture content in this study were higher than those previously found. In fact, compared to cellulosic fibers in general, tested under similar conditions, the experimental tensile strengths are higher than any other reported, whereas the experimental MOE values fall within the range and above the median.

The maximum tracheid tensile strength found in this study was 238 kg/mm². This was considerably less than a recent theoretical calculation of the axial tensile strength of a cellulose molecule of 1930 kg/mm² (Mark 1967). The difference between these values reflects the fact that not all of

the tracheid cross section consists of axially aligned structural cellulose.

A stress analysis designed to ascertain the degree of internal stress on the tangential walls of the S2 layer indicated that stress on the cellulosic framework was 8.3 times the total applied stress (Mark 1967; Mark and Gillis 1970). Using this adjustment factor, the maximum axial tensile strength of cellulose in this study becomes 1970 kg/mm², which is in the same order of magnitude of the theoretical value. The finding suggests that cellulose microfibrils are highly crystalline along their entire length and that cellulose chains are not likely to have a folded configuration. The fact that the estimated internal stress of the majority of experimental test specimens was less than the theoretical can be explained on the basis of flaws in the cellulosic framework.

CONCLUSIONS

Based on the results of this study, the following conclusions were drawn regarding the mechanical behavior of individual

Douglas-fir latewood tracheids of the type and under the conditions used in this investigation:

Freely dried wood tracheids stressed axially in tension exhibit load-elongation curves containing a short concave upward portion followed by a predominantly linear portion to failure. Failure is abrupt and generally not preceded by yield. The shape of the curves is affected very little by moisture content, suggesting that the external stresses in tracheids are borne primarily by a highly crystalline cellulosic framework. The lack of any clear-cut yield or plastic flow region indicates that the cellulosic framework exhibits little or no plastic deformation under short-term stress, presumably because large intermolecular forces prevent any extensive rheological movements.

Moisture content has a significant and complex effect on the tensile properties of tracheids. In the water-saturated state, delignified tracheids exhibit a minimum in breaking load, tensile strength, and modulus of elasticity. As these tracheids dry, their breaking loads and tensile strengths increase to a maximum at about 12% moisture content, and then decrease thereafter. Qualitatively, modulus of elasticity behaves similarly, but the maximum is reached at a moisture content of about 6%. Maxima in the strength property-moisture content relationships are due primarily to the differential effect moisture has on the hemi-cellulose and cellulose portions of the cell wall.

Internal stresses on the cellulose framework in the S2 layer of tracheids exhibiting the highest tensile strengths in this study were estimated to approach values theoretically calculated for crystalline cellulose. This suggests that tracheid microfibrils are highly crystalline with a good extended-chain crystal lattice and are not likely to contain disorganized or amorphous regions or cellulose chains with folded configuration.

REFERENCES

- BRECHT, W. 1962. Effect of structure on major aspects of paper behavior with fluids. Pages 427-466 in F. Bolam, ed. The formation and structure of paper. B. P. and B.M.A., London.
- BROUGHTON, R. M., JR. 1967. The effect of moisture content and swelling on the stress-strain behavior of paper. M.S. Thesis North Carolina State Univ., Raleigh, N.C.
- BROWN, K. C., J. C. MANN, AND F. T. PEIRCE. 1930. Influence of humidity on the elastic properties of cotton. V. Tensile behavior. *J. Text. Inst.* 21:T186-T197.
- BROWNING, B. L. 1967. Methods of wood chemistry. Volumes I and II. Interscience Publishers, New York.
- CLARK, J. D'A. 1969. Fibrillation, free water, and fiber bonding. *Tappi* 52(2):355-340.
- DINWOODIE, J. M. 1965. Tensile strength of individual compression wood fibres and its influence on properties of paper. *Nature* 205:763-764.
- DUMBLETON, D. F. 1972. Longitudinal compression of individual pulp fibers. *Tappi* 55(1):127-135.
- DUNCKER, B., AND L. NORDMAN. 1965. Determination of the strength of single fibres. Number 10, *Paperi ja Puu* 10:539-552.
- DUNCKER, B., AND L. NORDMAN. 1968. The mechanical properties of individual fibres. *Sven. Papperstidn.* 71(5):165-177.
- HARDACKER, K. W. 1962. The automatic recording of the load elongation characteristic of single papermaking fibers. *Tappi* 45(3):237-246.
- HARDACKER, K. W. 1969. Cross-sectional area measurement of individual wood pulp fibers by lateral compaction. *Tappi* 52(9):1743-1746.
- HARTLER, N., G. KULL, AND L. STOCKMAN. 1963. Determination of fibre strength through measurement of individual fibres. *Even. Papperstidn.* 66(8):301-308.
- HERMANS, P. H. 1499. *Physics and chemistry of cellulose fibres.* Elsevier, New York.
- IFJU, G. I. 1964. Tensile strength behavior as a function of cellulose in wood. *For. Prod. J.* 8:366-372.
- JAYNE, B. A. 1959. Mechanical properties of wood fibers. *Tappi* 42(6):461-467.
- JENTZEN, C. A. 1964. The effect of stress applied during drying on some of the properties of individual pulp fibers. *Tappi* 47(7):412-418; also *For. Prod. J.* 14(9):387-392.
- KADITA, S., T. YAMADA, AND M. SUZUKI. 1961. Studies on rheological properties of wood. *J. Jap. Wood Res. Soc.* 7(1):29-33.
- KALLMES, O. J., AND M. PEREZ. 1966. Load-elongation properties of fibres. Pages 507-528 in F. Bolam, ed. Consolidation of paper web. B. P. and B.M.A., London.
- KERSAVAGE, P. C. 1962. The effect of some chemical methods of fiber preparation on the tensile strength of Douglas fir fibers. M.S. Thesis, Univ. California, Berkeley, Calif.

- KERSAVAGE, P. C. 1971. The relationship between moisture content and tensile properties of Douglas fir summerwood tracheids. Ph.D. Thesis, Univ. Minnesota, Minneapolis, Minn.
- KLAUDITZ, W., A. MARSCHALL, AND W. GINZEL. 1947. Zur Technologie verholzter pflanzlicher Zellwände. *Holzforchung* 1(4):98-103.
- KOLLMANN, F. F. P. 1951. *Technologie des Holzes und der Holzwerkstoffe*. Springer-Verlag, Berlin.
- KOLLMANN, F. F. P., AND KRECH. 1960. Dynamic measurement of elastic properties of wood and of damping. *Holz Roh- Werkst.* 12(3):84-91.
- LEOPOLD, B., AND J. L. THORPE. 1968. Effect of pulping on strength properties of dry and wet pulp fibers from Norway Spruce. *Tappi* 51(7):304-308.
- MARK, R. 1967. Cell wall mechanics of tracheids. Yale Univ. Press, New Haven, Conn.
- MARK, R., AND P. P. GILLIS. 1970. New models in cell-wall mechanics. *Wood Fiber* 2(2):79-95.
- MCINTOSH, D. C., AND L. O. UHRIC. 1968. Effect of refining on load elongation characteristics of loblolly pine hollockulose and unbleached kraft fibers. *Tappi* 51(6):268-273.
- MEREDITH, R. 1956. Cellulose fibers. Pages 23-148 in R. Meredith, ed. *The mechanical properties of textile fibres*. Interscience Publishers, Inc., New York.
- MEYER, K. H., AND W. LOTMAR. 1936. Sur l'élasticité de la cellulose. *Helv. Chim. Acta* 19:68-75.
- NEGISHI, M. 1946. *J. Soc. Text. Cellul. Ind., Jap.*, 2:34-41. (As cited by Jentzen 1964).
- NEGISHI, M. 1947. *J. Soc. Text. Cellul. Ind., Jap.*, 3:21-30, 60-66. (As cited by Jentzen 1964).
- PAGE, D. H., F. EL-HOSSEINY, K. WINKLER, AND R. BAIN. 1972. The mechanical properties of single wood-pulp fibres. Part I: A new approach. *Pulp Pap. Mag. Can.* 73(8):T198-T203.
- RUSSEL, I., O. J. KALLMES, AND C. H. MAYHOOD. 1964. The influence of two wet-strength resins on fibers and fiber-fiber contacts. *Tappi* 47(1):22-25.
- SCHNIEWIND, A. P. 1966. Differences in the tensile strength of early and latewood tracheids. *Holz Roh- Werkst.* 24(10):502-506.
- SMITH, M. K., AND D. H. MORTON. 1968. Techniques for measurement of individual fibre properties. A comparison of pulp fibres from *Pinus radiata* and *Pinus elliottii*. *APPITA, Melbourne* 21(5):154-163.
- STONE, J. E., AND A. M. SCALLAN. 1967. The effect of component removal upon the porous structure of the cell wall of wood. II. Swelling in water and the fiber saturation point. *Tappi* 50(10):496-501.
- TAMOLANG, F. N., F. F. WANGAARD, AND K. M. KELLOGG. 1967. Strength and stiffness of hardwood fibers. *Tappi* 50(20):68-62.
- TAPPI STANDARD. 1954. Lignin in wood. T13 m-54, Tappi, New York.
- VAN DEN AKKER, J. A., A. L. LATHROP, M. H. VOELKER, AND L. R. DEARTH. 1958. Importance of fiber strength to sheet strength. *Tappi* 41(8):416-425.
- WAKEHAM, H. 1954. Mechanical properties of cellulose and its derivatives. Pages 1247-1356 in E. Ott, H. M. Spurlin, and M. W. Grafflin, eds. *Cellulose and cellulose derivatives*. Interscience Publishers, Inc., New York.
- WARDROP, A. B. 1951. Cell wall organization and the properties of the xylem. I. Cell wall organization and the variation of breaking load in tension of the xylem in conifer stems. *Aust. J. Sci. Res. B* 4:391-414.
- ZYLINSKI, T. 1958. *Nuka o Wloknie (Fiber Science)*. Panstwowe Wydawnictwo Przemyslu Lekkiego i spozywezego, Warszawa. Translation OTS 60-21550, Office of Tech. Serv., U.S. Dept. Comm., Washington 25, D.C.