





Universitat Autònoma de Barcelona

## MOLECULAR STUDY OF IDIOPATHIC NEPHROTIC SYNDROME

Gemma Bullich Vilanova

**ADVERTIMENT.** L'accés als continguts d'aquesta tesi queda condicionat a l'acceptació de les condicions d'ús establertes per la següent llicència Creative Commons:  [http://cat.creativecommons.org/?page\\_id=184](http://cat.creativecommons.org/?page_id=184)

**ADVERTENCIA.** El acceso a los contenidos de esta tesis queda condicionado a la aceptación de las condiciones de uso establecidas por la siguiente licencia Creative Commons:  <http://es.creativecommons.org/blog/licencias/>

**WARNING.** The access to the contents of this doctoral thesis it is limited to the acceptance of the use conditions set by the following Creative Commons license:  <https://creativecommons.org/licenses/?lang=en>

DOCTORAL THESIS

**MOLECULAR STUDY OF IDIOPATHIC  
NEPHROTIC SYNDROME**

**Gemma Bullich Vilanova**

*April 2016*



# Molecular study of idiopathic nephrotic syndrome

Thesis presented by  
**Gemma Bullich Vilanova**

To fulfil the PhD degree at  
**Universitat Autònoma de Barcelona**



Thesis realized under the direction of Dr. Elisabet Ars Criach and Dr. Roser Torra Balcells at the laboratory of Molecular Biology of Fundació Puigvert, Barcelona

Thesis ascribed to the Department of Cellular Biology, Physiology and Immunology, Faculty of Medicine, Universitat Autònoma de Barcelona

PhD in Cellular Biology

Dr. Elisabet Ars Criach  
*Director of the thesis Dr.*

Roser Torra Balcells  
*Director of the thesis Dr.*

Carme Nogués Sanmiquel  
*Tutor of the thesis*

Gemma Bullich Vilanova  
*PhD Candidate*  
Barcelona, April 2016



*Als meus pares i al Tayo,*

## AGRAÏMENTS

---

Aquesta tesi és el resultat de la contribució de molta gent sense la qual no hagués estat possible arribar fins aquí. Tots els que citaré, i espero no deixar-me ningú, heu posat el vostre granet de sorra (o un sorral sencer) en què aquesta tesi tirés endavant, moltes gràcies!

En primer lloc volia agrair de tot cor a les meves directores de tesi, l'**Elisabet Ars** i la **Roser Torra**, tot el que han fet per mi durant aquests anys. A l'**Elisabet**, moltíssimes gràcies per la teva enorme implicació en tots els aspectes, per estar sempre disposada a dedicar-me una estona, per ensenyar-me a pensar i a profunditzar, pel teu esperit crític, per tots els consells i per confiar en mi i en el meu criteri. De tu he après moltíssim a nivell científic però també a nivell personal, és un luxe treballar amb tu. A la **Roser**, moltíssimes gràcies per intentar trobar sempre un foradet en la teva atapeïda agenda, per resoldre tots els dubtes clínics, per aportar un punt d'optimisme als projectes, per implicar-me en altres projectes, per valorar-me tant, per haver-me consolat en els moments més estressants, per aconseguir que tingui un sou digne i per haver fet possible que d'aquí poquet me'n vagi a Holanda.

A la **Carme Nogués**, la tutora d'aquesta tesi, moltes gràcies per tota l'ajuda burocràtica, per facilitar-me al màxim tots els tràmits i per resoldre els meus dubtes.

Moltíssimes gràcies a les companyes del laboratori de Biologia Molecular per pintar de colors els dies grisos. A **Patricia**, per estar siempre dispuesta a ayudarme, por tus toques de humor que me encantan y por enseñarme a ser una persona ordenada y organizada dentro del lab, estoy segurísima que dónde sea que vaya a trabajar echaré de menos una "lab manager" como tú. A la **Laura**, "la alegría de la huerta", per les teves ganes d'aprendre el que calgui i per encomanar-nos les teves rialles. A la **Luz**, l'altra "alegría de la huerta", per ensenyar-me que cal molt poc per ser feliç, per totes les xerrades d'ànims i per estar sempre disposada a ajudar-me en l'àmbit científic i no científic. A **Chiara**, per escucharme en los momentos bajos y filosofar sobre la vida y sobre si sirve para algo esto del doctorado, seguro que sí!!! Ah! y por resolverme las miles de dudas sobre el inglés! A l'**Elena**, per tota l'ajuda a tots els nivells, per preocupar-te sempre per com estic, pels bons consells, i per ser tan optimista i positiva, ets un sol. A la **Bea**, per haver-me ajudat tantes vegades en mil temes: científics, de vestuari, de tesi, d'allotjament... i per ensenyar-nos que si no hi ha risc físic no ens hem d'estressar, tan debò poguéu fer-ho! A la **Irene**, perquè si no fos per ella no faríem ni la meitat de sopars, ets la "lab manager" de la vida fora del laboratori i el cotxe oficial que tants "apuros" ens ha solucionat, gràcies per estar sempre disposada a ajudar! A la **Judit**, pels ànims en els moments tristos i per preocupar-te per mi. A l'**Iván**, el profe de bioinformàtica, per fer-me perdre la por a la pantalla negra i per tota l'ajuda en la NGS i la no NGS, en laborables i festius. A **Dani**, por su humor andaluz. I al **Toni**, la recent incorporació del laboratori, per cuidar-nos des de el primer dia amb croissants i braços de gitano, quin bon fitxatge!

Hi ha una sèrie de persones que ja no estan al laboratori però que sens dubte els he d'agrair la seva ajuda. A la **Sheila**, la meva "profe", ha estat un autèntic plaer seguir els teus passos i tenir-te com a referent en la SN, moltes gràcies per tot el que em vas ensenyar abans de marxar i per estar sempre disposada a resoldre'm tots els dubtes. A **Deborah**, mi gran compañera de atardeceres románticos en la Puigvert, ¡cómo te he echado de menos estos últimos años! Muchas gracias por todos tus consejos y por compartir tantos momentos dulces y amargos. A l'**Olga Sancho**, la psicòloga, gràcies per ajudar-me a encarar el doctorat (i la vida) d'una manera constructiva. A **Paola**, ¡suerte de tu optimismo durante el proyecto de los podocitos! Muchas gracias por todos los halagos y por valorarme tanto. A **Ania** por ser una buena y tener un gran corazón. A la **Laia**, la **Xènia** i la **Lluïsa**, sempre disposades a ajudar i a la **Mònica Vall**, per animar-me en els moments durs.

A part del laboratori de Biologia Molecular, la Fundació té grans persones a les quals he d'agrair la seva contribució en aquesta tesi. A **José Ballarín**, muchas gracias por todo tu apoyo, por proporcionarme una

situación laboral digna, por valorar tanto nuestro trabajo y por estar siempre dispuesto a resolver mis dudas. A la **Silvia Mateu**, moltes gràcies per totes les gestions, pel “papeleo” i per tots els ànims. A **Montse Díaz** y **Artur Oliver**, por vuestra ayuda en el estudio de membranas. A la **Silvia** y la **Charo**, pels ànims i per fer-me sentir que tot el daltabaix emocional que comporta escriure la tesi és normal. A les doctorandes nefròlogues, **Nàdia, Iara** i **Mònica** per totes les paraules de suport i els ànims, en especial a la **Nàdia**, ha estat un plaer ajudar-te en les nefropaties intersticials, només et queda escalar una mica més de muntanya fins arribar al cim, molts ànims! A l'**Olga López** pels elogis i la teva motivació. Al **Ricard Pallejà**, per tots els articles que m'has aconseguit amb una gran rapidesa. A la **Núria Vinyolas** per la seva disposició a ajudar-me en el què calgués. A tots els **nois d'arxius**, per tenir sempre apunt una paraula simpàtica i un somriure. A l'**Ignasi Gich**, pel suport estadístic i a la **Carolyn Newey** per les correccions de l'anglès.

Agrair també al **Xavier Estivill** per acollir-me al seu laboratori del CRG durant la nostra col·laboració. Al **Dani** i al **Justo** per ensenyar-me tots els trucs i secrets de la NGS.

Hi ha algunes persones que tot i no estar presents en el dia a dia han tingut un paper molt decisiu en l'inici d'aquesta tesi. Volia agrair al **Pep** per fer que una simple conversa es convertís en una gran oportunitat. Al **Josep Fargues** per escoltar-me, aconsellar-me i ajudar-me ja abans d'emprendre aquest camí. Durant tots aquests anys me n'he recordat en molts moments de la teva frase: el doctorat és una cursa de resistència. Quina gran veritat! A la **Naiara**, moltes gràcies per tots els bons consells i per encomanar-me la il·lusió per la ciència.

A les bioquímiques, gràcies per no defallir en organitzar sopars! A la **Georgina**, moltíssimes gràcies per les trucades, per cuidar-me i preocupar-te per mi, pel punt d'optimisme i les ganes de tirar endavant que sempre em dónes, ets una gran amiga, hem compartit tot des de que vam entrar al món de la ciència i no puc estar més orgullosa de l'amiga que he descobert, espero poder-te ajudar en la teva tesi tant com tu has fet amb la meva. A l'**Àstrid**, l'escriptora de tesi exprés (quina enveja!) i aventurera, per transmetre aquesta motivació i ganes de tirar-te a la piscina, espero que aviat organitzem un viatge a París! A la **Laura**, la primera doctora del grup, gràcies per tots els consells i per compartir molts moments i dubtes sobre el futur durant el màster. A la **Mireia** perquè la seva motivació i ganes de fer coses alegren el dia a qualsevol i a la **Hannah**, quina sort coincidir al CRG i tornar-nos a retrobar! I també a la resta de colla de la uni, **Guillem, David, Raquel** i **Gemma** per compartir penes dins i fora del doctorat i perquè no em puc imaginar els anys d'universitat sense vosaltres.

Als “runners” moltes gràcies per transmetre superació km darrera km. A la **Mayte** per aguantar totes les vivències del doctorat i de la vida en general. Al **Roger, René, Raúl, Lluís, Uri** i a les 2 **Patris**, moltes gràcies per aguantar les angústies del doctorat i treure'm de casa de tant en tant. Al **David** i l'**Òscar** per ajudar-me a enderrocar tots els murs i per preocupar-vos per mi, mai oblidaré els 100km!!!

Els amics te'ls vas trobant pel camí de la vida però sovint el destí els separa i no els pots veure tant com voldries. **Gemma**, moltes gràcies per estar sempre disposada a ajudar-me, per animar-me en tot moment i per fer aquesta portada tant xula, ets genial!!! **Martí**, moltes gràcies per estar al meu costat en els moments difícils i per acceptar les meves decisions. **Marta Cuenca**, gràcies per no defallir en veure'ns encara que les respectives vides ho posin difícil i per estar sempre disposada a escoltar-me, espero poder veure't més sovint a partir d'ara. A les nenes de Ganàpies **Eva, Anna Palou, Anneta** i **Santako**, per tots els viatges que hem compartit, pels ànims que m'heu donat tots aquest anys i per entendre els “no puc he de fer tesi”. Als amics granollerins, **Marta** i **Edmon, Elisenda** i **Joan**, per aportar rialles i bons moments als caps de setmana de tesi, moltes gràcies!

A la família Castelluda, moltes gràcies per ser la millor segona família que podria tenir. A **Pepe** i **Imma**, per acollir-me a la vostra família, per cuidar-me i preocupar-vos per mi i per valorar tant el que faig. A



**Santi, Montse, José, Carol, Imma i Toni**, gràcies per tot el suport que m'heu donat tots aquests anys, per interessar-vos per com m'anava el doctorat i per aguantar més d'una conversa sobre articles i coses rares. A les xicotiques **Júlia i Mireia**, per arrancar-me sempre un somriure i fer-me passar tots els mals.

A la **laia**, lluitadora i riallera, moltes gràcies per ensenyar-me uns valors i una manera d'enfocar la vida que ha sigut clau per fer el doctorat. A l'**Avi** moltes gràcies per ensenyar-me la importància d'estudiar, de treure bones notes i per sentir-te tant orgullós de mi. Sempre us portaré amb mi.

Als meus pares, **Rosa i Francesc** m'heu donat les ales per arribar fins aquí. Gràcies per creure sempre en mi, per valorar-me tant, per estar al meu costat en els bons i mals moments, per acceptar les meves decisions, per fer-me aixecar en els moments difícils. Gràcies per ensenyar-me el valor de les coses, a ser humil, a lluitar pel què un vol. Sou el meu referent a la vida i si he arribat fins aquí és gràcies a vosaltres.

Al **Tayo**, per la seva ajuda infinita durant tots aquests anys. Ets una persona increïble i em sento molt afortunada de compartir la vida amb tu. Gràcies per estar al meu costat tots aquests anys, per creure tant en mi i en el què faig, per fer-me enfocar els problemes de la manera més constructiva i per ajudar-me a aixecar en tots els moments tristos. Ets el meu príncep blau, la parella que em cuida, l'amic que escolta, el pallasso que fa riure, l'aventurer amb qui viure experiències inoblidables, un mestre dins i fora de l'escola i una de les persones que més admiro del món.

Per últim voldria donar les gràcies a tots aquells **pacients** que ens han donat la seva mostra i han fet possible aquesta tesi, així com a tots els **clínic**s que han col·laborat en l'estudi d'aquests pacients i ens han ajudat a seguir aprenent. Aquest estudi tampoc hauria estat possible sense el finançament per part del **Ministerio de Sanidad** (FIS/FEDER 09/01506, FIS/FEDER 12/01523, FIS/FEDER PI13/01731 i FIS/FEDER PI15/01824) i la **REDinREN**.

## TABLE OF CONTENTS

---

ABBREVIATIONS .....	1
PRESENTATION .....	5
INTRODUCTION .....	7
1. KIDNEY ANATOMY AND PHYSIOLOGY.....	9
2. THE GLOMERULAR FITLRATION BARRIER .....	11
2.1. FENESTRATED ENDOTHELIUM .....	11
2.2. GLOMERULAR BASEMENT MEMBRANE.....	13
2.3. PODOCYTES .....	16
3. NEPHROTIC SYNDROME.....	19
3.1. CLINICAL MANIFESTATIONS .....	20
3.1.1. Proteinuria.....	20
3.1.2. Hypoalbuminemia .....	21
3.1.3. Edema.....	21
3.1.4. Hyperlipidemia .....	22
3.2. COMPLICATIONS .....	23
3.2.1. Thrombosis.....	23
3.2.2. Acute renal insufficiency .....	23
3.2.3. Endocrin alterations .....	24
3.2.4. Infections.....	24
3.3. ETIOLOGY OF NEPHROTIC SYNDROME .....	24
3.3.1. Congenital Nephrotic syndrome of Finnish Type .....	24
3.3.2. Diffuse mesangial sclerosis.....	26
3.3.3. Minimal change disease .....	26
3.3.4. Focal segmental glomerulosclerosis .....	27
3.3.5. Membranous nephropathy .....	29
3.4. TREATMENT.....	30
3.4.1. General management.....	30
3.4.2. Treatment in CNS .....	31
3.4.3. Treatment in children and FSGS/MCD adults .....	31

3.4.3.1.	Corticosteroid therapy .....	31
3.4.3.2.	Immunosuppressive therapy .....	32
3.4.4.	Treatment in MN .....	32
4.	PATHOGENESIS OF IDIOPATHIC NEPHROTIC SYNDROME .....	34
4.1.	IMMUNE COMPLEXES DEPOSITION: MN .....	35
4.2.	T CELL DEPENDENT CIRCULATING FACTOR: SSNS AND SDNS .....	37
4.3.	GENETIC CAUSE: SRNS.....	38
5.	GENETICS OF SRNS .....	42
5.1.	Autosomal recessive isolated SRNS and FSGS.....	42
5.1.1.	<i>NPHS1</i> gene .....	43
5.1.2.	<i>NPHS2</i> gene .....	45
5.1.3.	<i>PLCE1</i> gene .....	47
5.1.4.	<i>CD2AP</i> gene .....	49
5.1.5.	<i>PTPRO</i> gene .....	50
5.1.6.	<i>MYO1E</i> gene .....	50
5.1.7.	<i>ARHGDI1</i> gene.....	51
5.1.8.	<i>ADCK4</i> gene .....	51
5.1.9.	<i>TTC21B</i> gene.....	52
5.1.10.	<i>CRB2</i> gene.....	54
5.1.11.	<i>NUP107</i> gene.....	54
5.1.12.	<i>NUP93</i> gene.....	55
5.2.	Genes implicated in autosomal dominant isolated SRNS and FSGS .....	56
5.2.1.	<i>WT1</i> gene .....	56
5.2.2.	<i>ACTN4</i> gene .....	58
5.2.3.	<i>TRPC6</i> gene.....	59
5.2.4.	<i>INF2</i> gene.....	61
5.2.5.	<i>LMX1B</i> gene.....	63
5.2.6.	<i>ANLN</i> gene.....	63
5.2.7.	<i>PAX2</i> gene.....	64
5.3.	Genes implicated in syndromic forms of SRNS and FSGS .....	65
6.	CLINICAL UTILITY OF GENETIC TESTING .....	67
AIMS .....		71

RESULTS.....	75
STUDY I.....	77
<i>HLA-DQA1</i> and <i>PLA2R1</i> Polymorphisms and Risk of Idiopathic Membranous Nephropathy	77
STUDY II.....	93
Targeted next-generation sequencing in steroid-resistant nephrotic syndrome: mutations in multiple glomerular genes may influence disease severity.....	93
STUDY III.....	113
Contribution of <i>TTC21B</i> gene to glomerular and cystic kidney diseases.....	113
STUDY IV.....	123
Clinical utility of a kidney-disease gene panel for genetic diagnosis of cystic and glomerular inherited kidney diseases.....	123
DISCUSSION.....	151
IDIOPATHIC NEPHROTIC SYNDROME.....	152
IDIOPATHIC MEMBRANOUS NEPHROPATHY: THE IMPORTANCE OF GENETICS.....	152
THE KIDNEY-DISEASE GENE PANEL: THE INTEGRATIVE APPROACH.....	155
SRNS/FSGS: FROM GENETICS TO GENOMICS.....	159
TTC21B GENE: CAUSATIVE AND MODIFYING ROLE.....	162
CONCLUSIONS.....	165
BIBLIOGRAPHY.....	169
ANNEXES.....	195



## ABBREVIATIONS

---

A, Ala	Alanine
AIIRA	Angiotensin II receptor antagonists
ACEi	Angiotensin-converting-enzyme inhibitors
AD	Autosomal dominant
ADAS	Autosomal dominant alport syndrome
ADPKD	Autosomal dominant polycystic kidney disease
ADTKD	Autosomal dominant tubulointerstitial kidney disease
AFP	Alpha-fetoprotein
ANP	Atrial Natriuretic Peptide
AR	Autosomal recessive
ARAS	Autosomal recessive alport syndrome
ARPKD	Autosomal recessive polycystic kidney disease
AS	Alport syndrome
Ca <sup>2+</sup>	Calcium ion
CAKUT	Congenital anomalies of kidney and urinary tract
C, Cys	Cysteine
CD2AP	CD2-Associated Protein
CI	Confidence interval
CKD	Chronic kidney disease
CN	Copy number
CNS	Congenital nephrotic syndrome
CNF	Congenital nephrotic syndrome of Finnish type
CNV	Copy number variant
CoQ <sub>10</sub>	Coenzyme Q10
D, Asp	Aspartic acid
DAD	Diaphanous regulatory domain
DAG	Diacylglycerol
Deletion/insertion	Indel
DID	Diaphanous inhibitory domain
DMS	Diffuse mesangial sclerosis
DNA	DeoxyriboNucleic Acid
DSC	Doubling of serum creatinine
E, Glu	Glutamic acid

ELISA	Enzyme-linked immunosorbent assay
ESRD	End-stage renal disease
F, Phe	Phenylalanine
FCGR3	Fc gamma receptor III
FH1, FH2	Formin homology domains 1, 2
FNIII	Fibronectin type III
fs	Frameshift
FSGS	Focal segmental glomerulosclerosis
g, mg	Gram, milligram
G, Gly	Glycine
GBM	Glomerular basement membrane
GEC	Glomerular endothelial cell
GFB	Glomerular filtration barrier
GFR	Glomerular filtration rate
h	Hour
h	Heterozygous
H	Homozygous
H, His	Histidine
HDL	High density lipoprotein
HLA-DQA1	HLA complex class II HLA-DQ $\alpha$ -chain1
IFA	Indirect fluorescent-antibody technique
IFT139	Intraflagellar transport protein 139
Ig	Immunoglobulin
IKD	Inherited kidney diseases
IMN	Idiopathic MN
INF2	Inverted formin 2
INS	Idiopathic nephrotic syndrome
IP3	Inositol 1,4,5-triphosphate
JATD	Jeune asphyxiating thoracic dystrophy
K, Lys	Lysine
kDa	Kilodalton
l, dl, ml	Liter, deciliter, milliliter
L, Leu	Leucine
LG	Laminin globular
LMX1B	LIM homeodomain-containing transcription factor 1B
LM-521	Laminin $\alpha$ 5 $\beta$ 2 $\gamma$ 1

LN	Laminin N-terminal
M, Met	Methionine
m <sup>2</sup>	Metre square
MAF	Minor allele frequency
MCD	Minimal change disease
mDias	Mouse Diaphanous-related formins
MG	Mutation group
min	Minutes
MLPA	Multiplex ligation-dependent probe amplification
Mmol	Millimole
MN	Membranous nephropathy
mo	Months
MOI	Mode of inheritance
MYO1E	Myosin 1E
n	Sample size
N, Asn	Asparagine
NC1	Noncollagenous domain
ND	No data
NEP	Neutral endopeptidase
NGS	Next-generation sequencing
Nm	Nanometre
NPHP	Nephronophthisis
NPHP-RC	Nephronophthisis-related ciliopathies
NS	Nephrotic syndrome
NSR	Non-spontaneous remission
OR	Odds ratio
P	P Value
P, Pro	Proline
PCR	Polymerase chain reaction
PH	Pleckstrin homology
PKD	Polycystic kidney disease
PLA2R1	M-type phospholipase A2 receptor
PLCε1	Phospholipase C epsilon 1
PLC_X, PLC_Y	Phospholipase catalytic domains
Q, Gln	Glutamine
R, Arg	Arginine



RA1, RA2	RasGTP binding domain from guanine nucleotide exchange factors
RAAS	Renin-angiotensin-aldosterone system
RasGEF_CDC25	Guanine nucleotide exchange factor for Ras-like small GTPases
Ref	Reference
rs	RefSNP
S, Ser	Serine
sd	Syndrome
SD	Standard deviation
SDNS	Steroid-Dependent Nephrotic Syndrome
SNP	Single nucleotide polymorphism
SOD2	Superoxide dismutase 2
SRNS	Steroid-Resistant Nephrotic Syndrome
SSNS	Steroid-Sensitive Nephrotic Syndrome
suPAR	Soluble urokinase plasminogen activator receptor
T, Thr	Threonine
THSD7A	Thrombospondin type-1 domain-containing protein 7A
TM	Transmembrane
TRP	Tetratricopeptide repeat domains
TS	Tuberous sclerosis
UCV	Unclassified sequence variants
uPAR	Urokinase plasminogen activator receptor
V, Val	Valine
VEGF	Vascular endothelial growth factor
vs	Versus
VS	Variant score
WAGR	Wilms tumor, aniridia, genitourinary abnormalities, and mental retardation
WT1	Wilms Tumor 1
XLAS	X-linked alport syndrome
Y, Tyr	Tyrosine
y, yr	Years
*	Stop codon

## PRESENTATION

---

This thesis is a contribution to the knowledge of the molecular bases of idiopathic nephrotic syndrome. It has been performed in the Molecular Biology laboratory of Fundació Puigvert in Barcelona. This laboratory performs genetic diagnostic of inherited renal diseases since 2002 as well as research on the molecular bases of these diseases.

The first part of this thesis presents the association of genetic polymorphisms with the risk to develop idiopathic membranous nephropathy and with its clinical course. Our results showed that risk alleles within *HLA-DQA1* and *PLA2R1* genes are associated with a higher risk of idiopathic membranous nephropathy. In addition, the combination of the risk alleles for both genes results in an increased risk of idiopathic membranous nephropathy. For the first time, we presented evidence of the contribution of these polymorphisms to predict response to immunosuppressive therapy and decline in renal function.

The second part of these thesis focuses on the study of the molecular basis of steroid-resistant nephrotic syndrome. Our results contribute to enhance the genotypic spectrum associated with this disease in several aspects: 1) mutations in an SRNS/FSGS gene together with *COL4A3* have been detected in patients with increased disease severity, 2) the homozygous p.P209L mutation in *TTC21B* gene is not the only causative mutation of FSGS, and 3) heterozygous deleterious *TTC21B* variants may aggravate the phenotype of patients with glomerular and cystic kidney inherited kidney diseases. In addition our results also improved the genetic diagnosis of inherited kidney diseases. We developed a kidney-disease gene panel that allowed a more comprehensive characterization of patients enabling the differential diagnosis of cystic and glomerular inherited kidney diseases and the identification of structural variants, complex inheritance patterns and mosaic mutations. This approach is currently used in routine genetic diagnostic of patients from all over Spain and other countries, providing a nice example of translational research.

This thesis consisted of six parts. The introduction section describes the generalities of the glomerular filtration barrier, as well as the clinical features and molecular bases of idiopathic nephrotic syndrome. The aims section reflects the global and the particular aims of the present thesis. The Results section contains the four studies performed in this project with a summary of each one at the beginning. These results are discussed the Discussion section. Finally, the conclusions derived from our results are presented in the Conclusion section.



# INTRODUCTION

---



## 1. KIDNEY ANATOMY AND PHYSIOLOGY

---

The kidney's main function is to filter waste materials out of the blood and pass them out of the body as urine. The kidney's microscopic functional units that filter blood to produce urine are nephrons. An adult human kidney is known to contain an average of one million nephrons. Based on their location, there are two types of nephrons: cortical nephrons (85%), which are located deep in the renal cortex, and juxtamedullary nephrons (15%), which lie in the renal cortex close to the renal medulla (Figure 1).

Nephrons are functionally divided into a filtration unit called the renal corpuscle and a reabsorption unit named the renal tubule:

- The **renal corpuscle** is composed of the glomerulus and Bowman's capsule, separated by the urinary space also named Bowman's space.
  - o The glomerulus is a network of tangled capillaries where the actual filtering takes place. It is composed of three cell types: glomerular endothelial cells that form the intricately tortuous inner capillary tuft; podocytes or visceral epithelial cells that tightly wrap around the exterior of glomerular capillaries; and mesangial cells that together with the mesangial matrix provide a structural reinforcement for the glomerular vasculature. Glomerular endothelial cells and podocytes share a common extracellular cell matrix known as the glomerular basement membrane (GBM). These three layers form the glomerular filtration barrier (GFB).
  - o Bowman's capsule is a cuplike enclosure composed of parietal epithelial cells that surround the tuft of capillaries.
- The **renal tubule** is a long convoluted structure that emerges from the glomerulus. Its function is to concentrate urine and recover non-waste solutes from the primary urine. It is divided into three parts based on their function: the proximal convoluted tubule, the loop of Henle and the distal convoluted tubule, which empties its filtrate into collecting ducts.

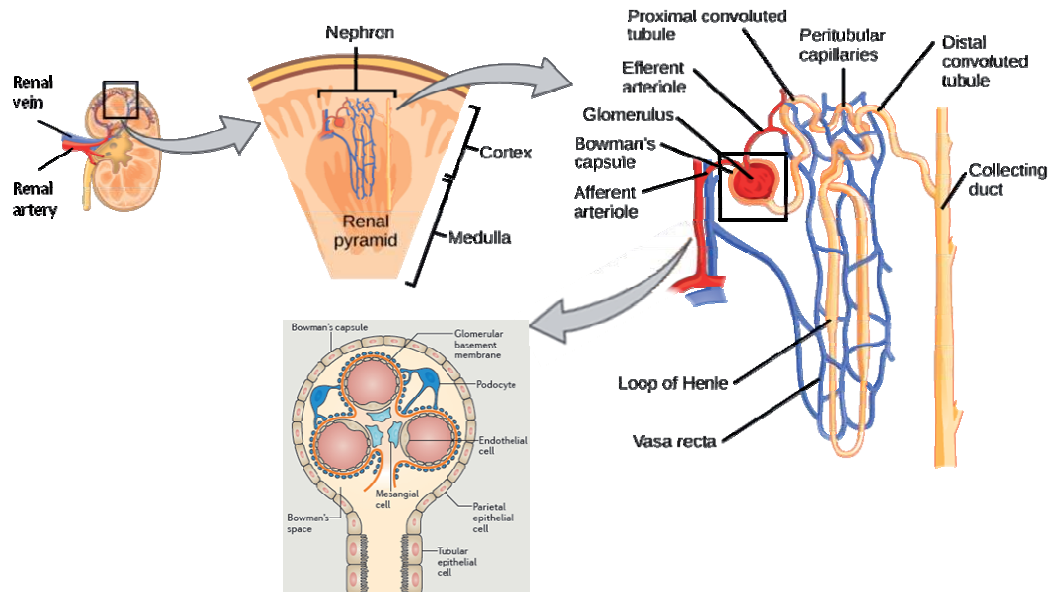

**Figure 1.** Basic kidney anatomy (adapted from: "Kidney Structure." *Boundless Biology*. and Kurts *et al.*, 2013).

The renal artery enters the kidney through the renal hilus and branches into small arterioles that carry the blood to the renal cortex. In the renal cortex, blood enters to the glomeruli through the afferent arteriole in the vascular pole. Inside the glomerulus, the afferent arteriole immediately branches into the elaborated glomerular capillary tuft. Low-molecular-weight plasma waste products are filtered across the GFB forming the primary urine in the urinary space, while the passage of albumin and larger macromolecules (>15 kDa) that are necessary for maintaining normal homeostasis is restricted. The filtrated blood exits the glomeruli through the efferent arterioles. The efferent arterioles descend into the renal medulla and separate into the peritubular capillaries. The peritubular capillaries surround the proximal and distal tubules, as well as the loop of Henle, where they are known as vasa. These capillaries converge into veins that end in the renal vein.

The primary urine formed in the urinary space flows to the proximal convoluted tubule at the urinary pole of the renal corpuscle. There, much of the water and nutrients initially filtered into the primary urine are reabsorbed. Then, the filtrate enters the loop of Henle that descends deep into the medulla of the kidney, makes a hairpin turn, and returns to the renal cortex. In the loop of Henle water and ions are reabsorbed. Next, the filtrate passes to the distal convoluted tubule and finally urine from the distal convoluted tubules of several nephrons enters the collecting duct. In this structures water and ions are still reabsorbed. The collecting duct carries the concentrated urine through the renal medulla and into the renal

pelvis. In the renal pelvis, urine from many collecting ducts combines and flows out of the kidneys and into the ureter.

## 2. THE GLOMERULAR FILTRATION BARRIER

---

The GFB lies between the vasculature and the urinary space being the only barrier between the bloodstream and the primary urine. This structure is a dynamic and highly selective filter that sieves on the basis of molecular size and electrical charge generating the primary urine.

The driving component of the glomerular filtration is the glomerular pressure, which is highly controlled by the regulation of the vascular resistance of both afferent and efferent arteriole via different mechanisms. Other factors determining the glomerular filtration are the oncotic pressure due to the high concentration of intracapillary plasma proteins, and the hydrostatic pressure, exerted by a fluid at rest (Leeuwis *et al.*, 2010).

The GFB is composed of three layers: the fenestrated endothelium, the GBM and the podocytes, visceral epithelial cells with interdigitating foot processes that form the slit diaphragm (Figure 2).

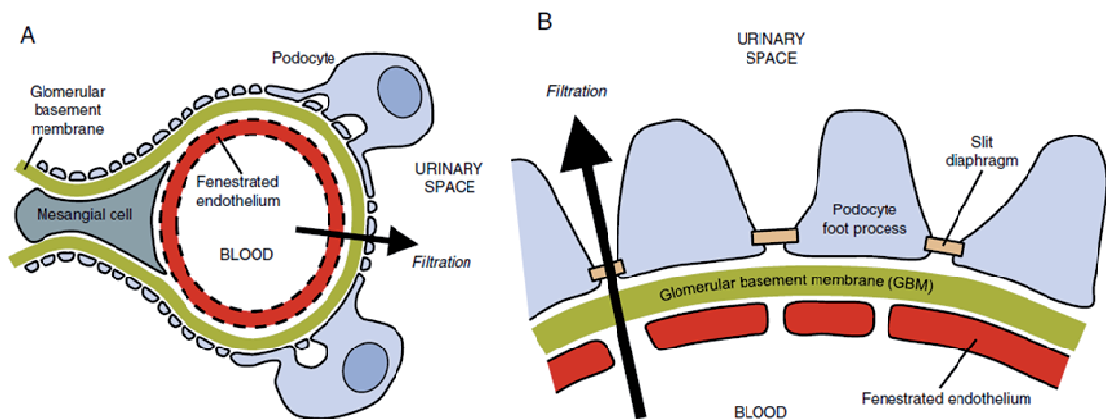

**Figure 2.** A) Schematic representation of a glomerular capillary loop showing interaction between podocytes, mesangial cells and the endothelium. B) Enlarged view of the glomerular filtration barrier: fenestrated endothelium, glomerular basement membrane and podocyte foot processes with the slit diaphragm (Leeuwis *et al.*, 2010).

### 2.1. FENESTRATED ENDOTHELIUM

---

The glomerular capillaries are heavily perforated with transcellular pores known as *fenestrae* and are not surrounded by smooth muscle cells. These *fenestrae* are 60-100 nm wide



and comprise approximately 20% of the endothelial surface, making glomerular capillaries efficient portals for the rapid passage of high volumes of fluid. Based on the *fenestrae* size, one would expect that albumin (3.5 nm of radius) could pass through the *fenestrae* (Levick & Smaje 1987). However, the fenestrated endothelium has a very low sieving coefficient of albumin indicating that the glomerular endothelium plays an active role in renal filtration (Sarin 2010).

The glycocalyx is a negative-charged gel-like surface structure that lines the luminal face of glomerular capillaries and the fenestral surfaces, and acts as a size barrier to albumin filtration (Rostgaard & Qvortrup 2002). It is composed of proteoglycans with their bound glycosaminoglycans, glycoproteins and glycolipids. Around 90% of these glycosaminoglycans are heparin sulfate and hyaluronan and they act as a molecular scaffold. Plasma proteins are absorbed within the glycocalyx by binding multivalent to glycosaminoglycans, thus creating steric hindrance to protein filtration. This barrier function will be further modified by the fluid drag through the glycocalyx which allows for dynamic equilibrium with glycocalyx-bound and free circulating proteins (Haraldsson *et al.*, 2008).

The cell-surface-anchored glycocalyx and the broad coat of >200 nm thick formed by plasma proteins absorbed within the glycocalyx constitute the endothelial surface layer (Hjalmarsson *et al.*, 2004). This layer forms the first barrier to albumin passage across the glomerular filtration barrier and ensures that the albumin is largely confined to the capillary lumen (Figure 3).

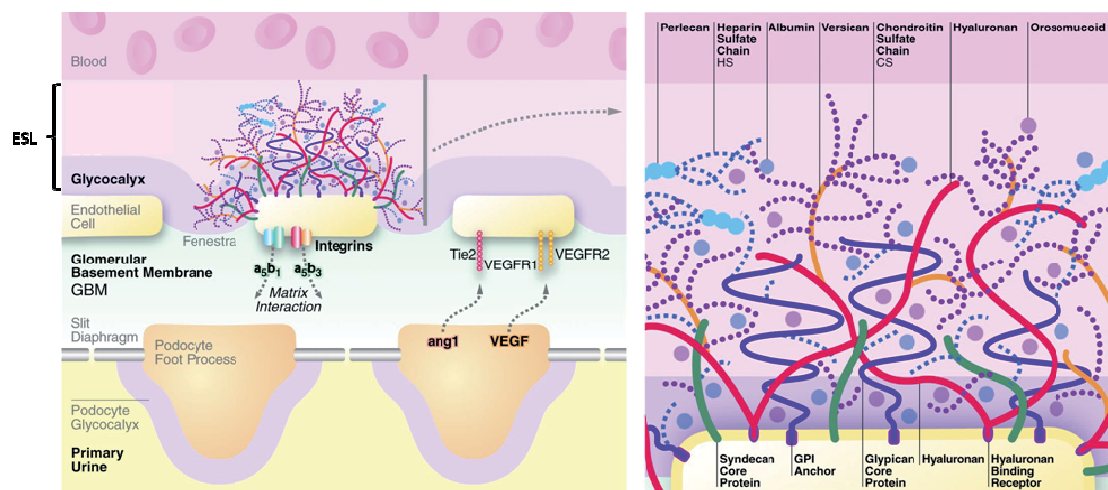

**Figure 3.** Schematic representation of the glomerular filtration barrier with a detailed view of the glycocalyx components. ESL, endothelial surface layer (adapted from Haraldsson *et al.*, 2008)

## 2.2. GLOMERULAR BASEMENT MEMBRANE

---

The GBM is a 250 to 400 nm thin meshwork of extracellular matrix proteins. Most of the GBM is situated between the glomerular endothelial cells and the podocytes although it is also found between mesangial cells and podocytes.

The GBM provides structural support for the glomerular capillaries and harbors ligands for receptors of the adjacent endothelial cells, podocytes, and mesangial cells (Yurchenco & Patton 2009; Miner 2005). In addition, it acts as a size- and charge-selective filtration barrier, impeding the passage of molecules negatively charged and molecules larger than approximately 5 nm (Deen *et al.*, 2001).

The GBM is composed of laminin, type IV collagen, heparan sulfate proteoglycan and nidogen (Figure 4). These components are synthesized by podocytes and glomerular endothelial cells and secreted to the extracellular space (St John & Abrahamson 2001). During glomerulogenesis the separate podocyte-derived and endothelium-derived basement membranes fuse to form the immature GBM. After glomerular maturation both podocytes and endothelial cells are equally important for maintaining its structure and function (Suh & Miner 2013).

- Laminins are large heterotrimeric glycoproteins composed of three different chains:  $\alpha$ ,  $\beta$  and  $\gamma$ . These chains assemble to form at least 15  $\alpha$ - $\beta$ - $\gamma$  distinct laminin trimers with cruciform, Y-shaped, or rod-shaped structures. Each laminin trimer has the following parts:
  - o A long arm formed by association of  $\alpha$ ,  $\beta$  and  $\gamma$  chains via coiled coil interactions and disulfide bonding. At the distal end, there is a large laminin globular (LG) domain formed exclusively by the C-terminal of the  $\alpha$  chain that link laminin trimers to the podocytes and endothelial cells via interactions with integrins and dystroglycans receptors.
  - o Three short arms called laminin N-terminal (LN) domains corresponding to the N-terminal globular domains of the three chains, which plays an essential role in polymerization of trimers to form a network.

The major laminin trimer found in the mature GBM is laminin  $\alpha 5\beta 2\gamma 1$  (LM-521) (St John & Abrahamson 2001). Once laminin is secreted to the extracellular space, laminin trimers self-polymerize by interactions among LN domains and form a laminin network

(Cheng *et al.*, 1997). This polymerization step is a reversible and calcium-dependent process that requires a minimum concentration of laminin trimers to form an initiation complex (Yurchenco & Cheng 1993). Therefore, laminin appears to be essential for the initial formation of GBM. Then, interactions of laminin with other basement membrane molecules (type IV collagen, nidogen, and sulfated proteoglycan) enable the assembly of a GBM.

- Type IV collagens represent half the total proteins of a mature GBM. There are 6 genetically distinct collagen IV  $\alpha$  chains ( $\alpha 1$ - $\alpha 6$ ) and they assemble to form three different protomers, each composed of three  $\alpha$  chains:  $\alpha 1\alpha 1\alpha 2$ ,  $\alpha 3\alpha 4\alpha 5$  and  $\alpha 5\alpha 5\alpha 6$ . Each collagen IV  $\alpha$  chain has three domains: the N-terminal 7S domain, a central collagenous domain and a noncollagenous domain (NC1) at the C-terminus.

The central collagenous domain consists of many Gly-X-Y amino acid triplet repeats (with X and Y usually being lysine or proline) that allow the assembling of the chains into a triple helix. There are also multiple interruptions of the Gly-X-Y repeats scattered throughout the collagenous domain that provide flexibility to the collagen IV protomers and therefore, to the collagen IV network. Both the 7S and the NC1 domains are involved in linking trimers to each other to promote collagen IV network formation. In addition, the NC1 domain is crucial for directing the composition of collagen heterodimers.

Maturation of the GBM involves the transition of the  $\alpha 1\alpha 1\alpha 2$  collagen to the  $\alpha 3\alpha 4\alpha 5$  collagen protomers as the predominant collagen complex. This transition might be required to accommodate the increased blood pressure after birth, since  $\alpha 3\alpha 4\alpha 5$  type IV collagen produces a more heavily cross-linked and more protease-resistant network compared to the  $\alpha 1\alpha 1\alpha 2$  type IV collagen network (Miner & Sanes 1994).

- Nidogen-1 and nidogen-2 are two homologous glycoproteins containing three globular-like domains with two rod-like domains that separate the globular-like domains. Nidogen-1 binds to both, laminin  $\gamma 1$  chain short arm and type IV collagen. Nidogens are supposed to provide extra stability to GBM under situations of unusual stress, but they are not required for the initial formation of the GBM.
- Heparan sulfate proteoglycans have a protein core with covalently linked sulphated glycosaminoglycan side chains. The sulphated side chains give a negative charge to the proteoglycan, however they do not seem to play critical roles in the GFB. The most

common heparan sulphate proteoglycan in mature GBM is agrin, although in glomerulogenesis there appears to be co-distribution of perlecan and agrin (Groffen *et al.*, 1998). The N-terminal domain of agrin binds avidly to the LM-541 long arm, and its C-terminal contains domains that can bind to cell-surface receptors such as dystroglycan and integrins. These properties of agrin suggest that it could be implicated in mediating charge selectivity within the GFB and in linking the GBM to the adjacent cells. In addition, heparan sulphate side chains are important for binding and sequestering growth factors in some contexts, such as the passage of vascular endothelial growth factor (VEGF) from podocytes to fenestrated endothelium.

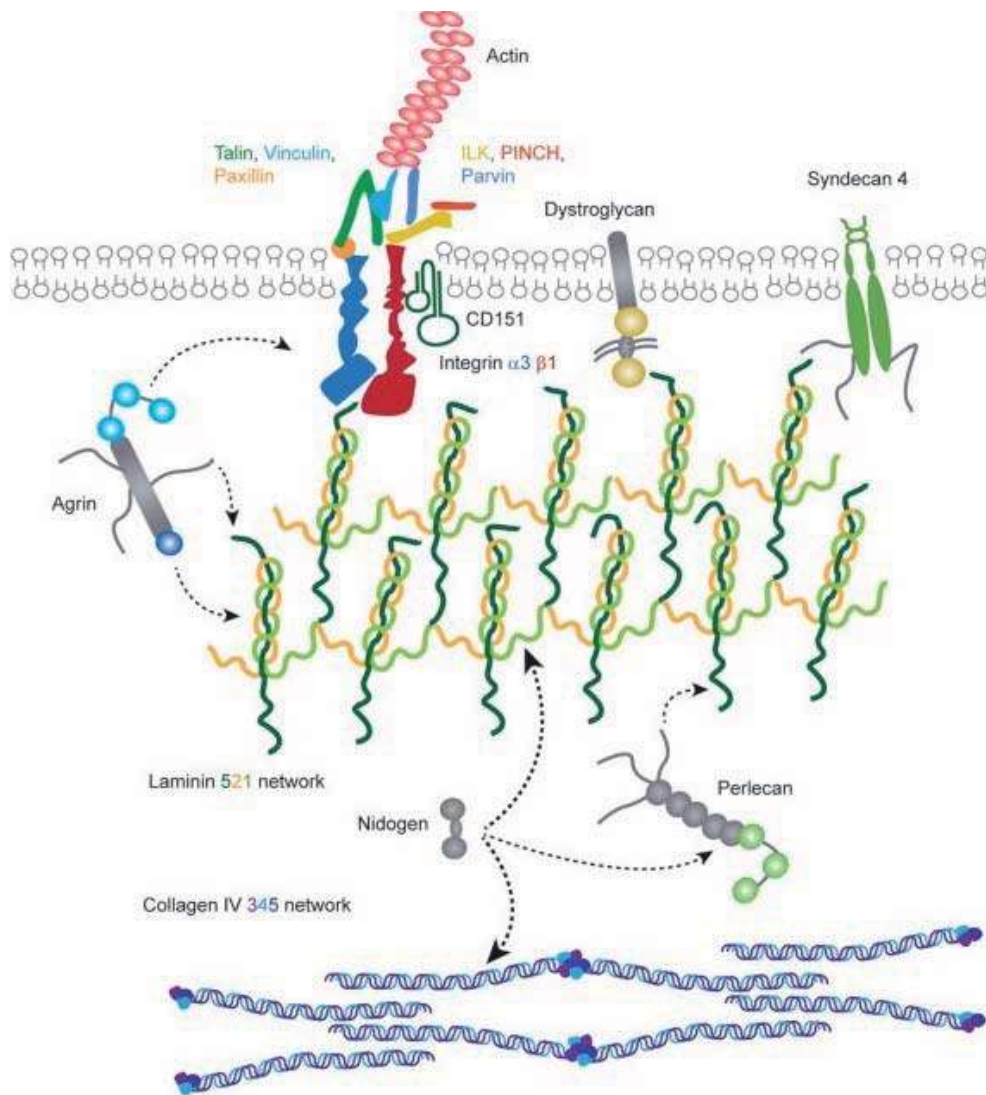

**Figure 4:** Components of the glomerular basement membrane and the podocyte-glomerular basement membrane interface (Lennon *et al.*, 2014).

These components are distributed as a highly organized labyrinth of interconnected polygonal fibrils of varying thickness ranging from 4 to 10 nm. The fibrils are more densely

packed within the core where they have heterogeneous pores averaging 10 nm in diameter. The  $\alpha3\alpha4\alpha5$  collagen is concentrated at the core with the minor  $\alpha1\alpha2$  closer to the endothelial side, whereas the laminin LM-521 and agrin are biomodally distributed (Figure 5) (Scott & Quaggin 2015).

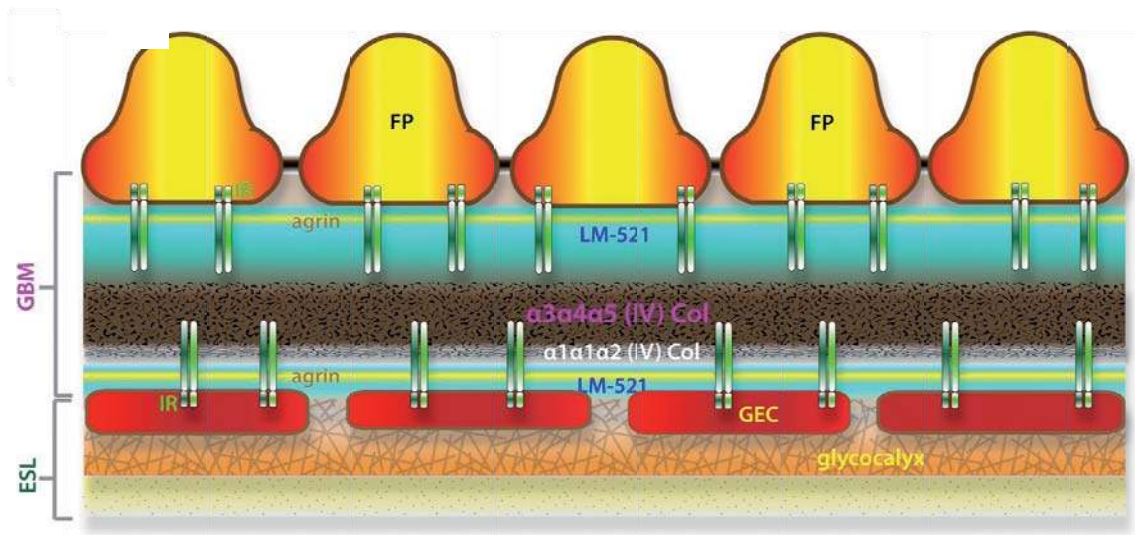

**Figure 5.** Molecular organization of the glomerular basement membrane. ESL, endothelial surface layer; FP, foot processes; GBM, glomerular basement membrane; GEC, glomerular endothelial cell; IR, integrin receptor (Scott & Quaggin 2015).

### 2.3. PODOCYTES

Podocytes are highly specialized, terminally differentiated epithelial cells that enwrap the outer aspect of the GFB. They perform highly specialized functions, which includes: a size barrier to proteins, a charge barrier to proteins, maintenance of the capillary loop shape, counteraction of the intraglomerular pressure, synthesis and maintenance of the GBM, and production and secretion of VEGF required for glomerular endothelial cells integrity (Shankland 2006).

Mature podocytes consist of morphologically and functionally different components: cell body, major processes, secondary processes and foot processes. The cell body essentially lies in the urinary space and it contains the nucleus and the cell machinery. From the cell body arise long major processes that branched into secondary processes, which in turn split into foot processes. Foot processes branch and interdigitate with neighboring foot processes, and adjacent foot processes are directly linked by the glomerular slit diaphragm. This complex structure of the podocyte is achieved by a unique cytoskeletal architecture consisting of



microtubule-rich major and secondary processes, and actin-based foot processes (Welsh & Saleem 2012)(Figure 6).

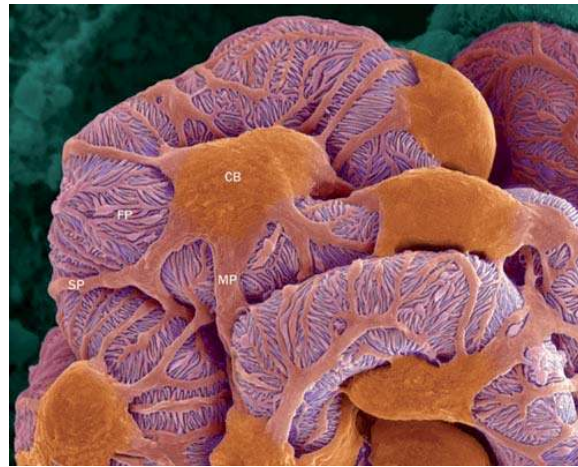

**Figure 6.** A scanning electron micrograph of podocyte cells in a glomerulus shows the cell body (CB), major processes (MP), secondary processes (SP) and the finely interdigitating foot processes (Dennis Kunkel Microscopy, Inc. Welsh & Saleem 2012)

Foot processes contain three distinct membrane compartments: the basal side, the apical side and the slit diaphragm. All three domains interact with the foot processes actin cytoskeleton, influencing signaling pathways and motility of the podocyte. The basal side anchors the podocyte to the GBM with several types of integrins and dystroglycans (Kreidberg *et al.*, 1996; Raats *et al.*, 2000). The apical side is negatively charged due to the presence of the anionic proteins podocalyxin, podoplanin, and podoendin (Kerjaschki *et al.*, 1984; Matsui *et al.*, 1999). This negative charge contributes to limit the passage of albumin (also negatively charged) and maintains the separation among adjacent podocytes.

The podocyte slit diaphragm is a unique cell-cell contact with zipper-like structure and a constant width of 40 nm (Rodewald & Karnovsky 1974). The podocyte slit diaphragm represents a separate class of specialized intercellular junction because it integrates structural components of various cell junction types, including tight, adhesion, gap and neural junctions (Reiser *et al.*, 2000; Schnabel *et al.*, 1990). Many of the molecular constituents of the slit diaphragms have been identified, although their topological assembly into a functional complex is poorly understood. The ectodomains of several adhesion receptors in the slit diaphragm likely organize the bridge linking juxtaposed foot processes via a combination of homophilic and heterophilic receptor-receptor interactions. By virtue of their large ectodomains, nephrin and Fat1 are excellent candidates to associate *in trans* to connect opposing foot processes (Inoue *et al.*, 2001; Khoshnoodi *et al.*, 2003) (Figure 7).

The slit diaphragm contains unique proteins that have to fulfill at least four different tasks: they act as a macromolecular filter, anchor the filter to the GBM, connect the slit diaphragm to the actin cytoskeleton via adaptor proteins, and are part of a signaling complex that integrates and mediates extracellular and intracellular signals regulating the plasticity of foot processes (Grahammer *et al.*, 2013).

The first unique slit diaphragm protein identified was nephrin, a type I transmembrane protein with a cytoplasmic C-terminus, a transmembrane domain, a fibronectin type III domain and eight extracellular C2-type immunoglobulin domains. Nephrin molecules interact *in trans* configuration with each other, and probably overlap in the middle of the gap to form a dense midline, giving the slit diaphragm its zipper-like appearance. Therefore, nephrin is considered the core biomechanical component of the molecular sieve (Tryggvason 1999; Ruotsalainen *et al.*, 1999).

The Neph-1, Neph-2 and Neph-3 proteins share certain homology with nephrin, but lack a fibronectin domain and only have five extracellular C2-type immunoglobulin domains (Sellin *et al.*, 2003). These molecules are probably too short to participate in homophilic interactions in *trans* configuration across the 40 nm gap of the slit diaphragm, but are likely to interact with nephrin in both *cis* and *trans* configurations (Gerke *et al.*, 2003; Barletta *et al.*, 2003). All three Neph proteins possess a THV motif near their C-terminal end, which can bind to PDZ domains, thereby enabling recruitment of scaffolding molecules, such as ZO-1 or the aPKC/PAR-3/PAR-6 polarity complex. Neph1 and nephrin seem to be involved in signaling events from the urinary space to the podocyte cytosol (Hartleben *et al.*, 2008).

The third unique slit diaphragm protein identified to date is podocin, a member of stomatin family of proteins. Podocin is anchored to the membrane via its central part and its N-terminal and C-terminal both face the cytoplasm. Podocin helps in the nephrin anchoring, seems to recruit other slit diaphragm proteins to cholesterol-rich membrane domains, and to increase the signaling properties of the nephrin-Neph1 complex (Huber, Simons, *et al.*, 2003; Garg *et al.*, 2007).

The scaffold proteins ZO-1, CD2-associated protein and MAGI-2, as well as CASK and the actin-binding proteins IQGAP1 and  $\alpha$ -actinin-4, anchor nephrin (and potentially other slit diaphragm proteins) directly or indirectly to the actin cytoskeleton, which is crucial to both foot process spacing and stability (Huber, Hartleben, *et al.*, 2003; Palmen 2002). These interactions probably strengthen the biomechanical properties of the slit diaphragm itself, and

might also enable it to relay signals to the actin cytoskeleton that, in turn, induce morphological changes to primary and secondary foot processes (Grahammer *et al.*, 2013).

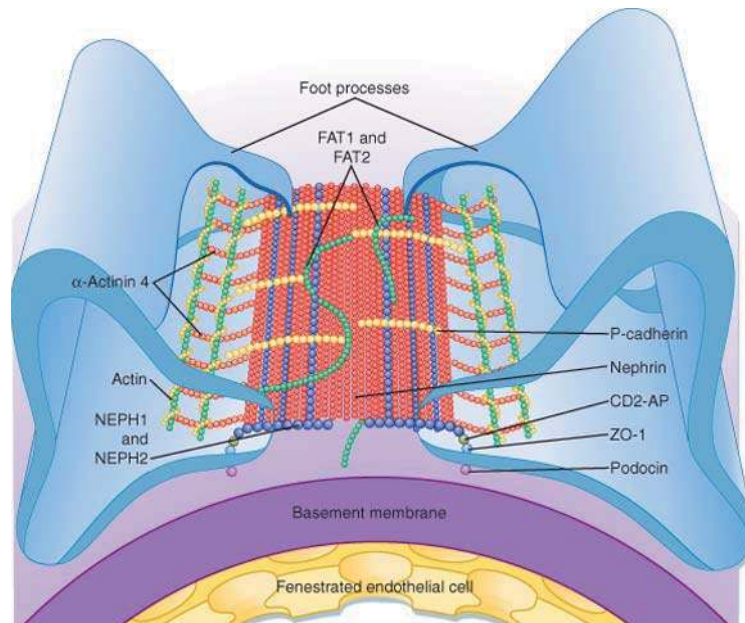

Figure 7. The glomerular slit diaphragm. An ultrathin slit diaphragm spans the filtration slit between the foot processes, slightly above the basement membrane (Tryggvason *et al.*, 2006).

### 3. NEPHROTIC SYNDROME

---

Nephrotic syndrome (NS) is characterized by massive proteinuria, hypoalbuminemia, and edema, although additional clinical features such as hyperlipidemia are also usually present. A recently published definition of NS considers that nephrotic range proteinuria of glomerular origin and a serum albumin concentration below the lower limit of normal are essential to NS definition whereas edema, hyperlipidemia and lipiduria are commonly associated but not essential (Glassock *et al.*, 2015).

The central abnormality in all cases of NS is the development of massive proteinuria. Physiologically, the liver tries to compensate for this excessive loss with increased protein and lipoprotein synthesis. NS develops when the loss of protein in urine exceeds the rate of albumin synthesis in the liver, resulting in hypoalbuminemia and edema.

NS represents one of the most common diagnoses in pediatric nephrology. The annual incidence is estimated to be 2-7 per 100.000 children, with a prevalence of 16 per 100.000 children in Western countries (Giglio *et al.*, 2015). There is a male preponderance among



young children, at a ratio of 2:1 to females, although this gender disparity disappears by adolescence, making the incidence in adolescence and adults equal among males and females.

### 3.1. CLINICAL MANIFESTATIONS

---

#### 3.1.1. Proteinuria

Proteinuria is a condition in which urine contains an abnormal amount of protein. Nephrotic range proteinuria is defined as the proteinuria capable of producing NS and is considered to be superior to  $3.5 \text{ g}/24\text{h}/1.73 \text{ m}^2$  in adults or  $40 \text{ mg}/\text{h}/\text{m}^2$  in children. However, the clinical manifestations of NS can appear with lower levels of proteinuria or be missing in patients with higher levels of proteinuria. For this reason, it is preferred to consider nephrotic range proteinuria, the proteinuria able to produce hypoalbuminemia.

The main proteins lost in NS have a molecular weight of 40-150 kDa, including albumin (the most abundant protein in plasma), IgG, transferrin, ceruloplasmin and  $\alpha$ 1-acid glycoprotein. There is also loss of small amounts of higher molecular weight proteins (200 kDa), like the small forms of high density lipoprotein (HDL). However, proteins higher than 200 kDa such as IgM, macroglobulins, fibrinogen, XIII factor, fibronectin and large lipoproteins are not lost even in case of severe proteinuria.

The amount of proteinuria can be influenced by other factors different from the glomerular damage such as the renin-angiotensin system activity, the hepatic capacity for albumin synthesis, the protein daily intake and the antihypertensive drug administration.

In healthy conditions, the GFB avoids the passage of molecules with a size superior to 70 kDa to the primary urine. Albumin has a molecular weight of 69 kDa and a net charge of -15 and is filtered through the GFB with a sieving coefficient of 0.0001. Interestingly, negatively charged proteins have an increased clearance compared to positive charged ones due to the negative charges in the GBM heparan sulfate proteoglycans.

Proteinuria in NS can be due to a structural alteration, disrupting the size selectivity of the GFB and leading to massive nonselective proteinuria, or to an electrochemical alteration, affecting the charge selectivity of the GFB and presenting with selective albuminuria.

### 3.1.2. Hypoalbuminemia

Hypoalbuminemia is a low level of albumin (inferior to 3 g/dl) in blood and it is a direct consequence of proteinuria. Albumin is the most abundant plasma protein and represents 70-90% of the proteinuria detected in NS. This filtrated albumin is in part catabolized by the renal tubule, which increases its catabolic rate. To compensate this loss of albumin in urine, the liver increases the albumin synthesis even in a 300%. When the proteinuria and the renal albumin catabolism exceed its hepatic synthesis, hypoalbuminemia appears. The severity of the hypoalbuminemia is well correlated with the amount of proteinuria although other factors such as the age, the nutritional state and the type of renal lesion also influence.

In addition to the hypoalbuminemia, there is a decrease in the serum immunoglobulins, especially IgG, whereas high molecular weight immunoglobulins remain normal or even elevated.

### 3.1.3. Edema

Edema is defined as an abnormal accumulation of fluid in the interstitial compartment. Edemas are the main reason for diagnosis in children with NS. They are soft, pitting and mainly localized in slope regions like foot or sacrum, and in regions with low tissue pressure such as periorbital region. In advanced disease, patients may develop periorbital or genital edema, ascites, or pleural effusion.

It is widely accepted that NS patients have an excess of total body sodium and water. Two major pathophysiological mechanisms have been proposed to explain the development of edema in NS based on the status of their intravascular volume: the underfilling hypothesis and the overfilling hypothesis.

In the underfilling hypothesis (Figure 8A), the hypoalbuminemia causes a decrease in the intravascular oncotic pressure. This in turn leads to fluid shift from intravascular to extravascular compartment and edema formation. The homeostatic response to the hypovolemia activates the renin angiotensin aldosterone system, the sympathetic nervous system and the release of antidiuretic hormone. Gradually, the plasma volume normalizes as a result of the increase of the extracellular space and the edema formation.

In the overfill hypothesis (Figure 8B), there is an intrinsic defect that enhances tubular sodium and water reabsorption, independently of the hemodynamic situation. This causes

intravascular volume expansion and increased intravascular hydrostatic pressure, which leads to edema formation. Several mechanisms to explain this sodium and water retention in NS patients with overfilling of the intravascular compartment have been proposed. Such patients show resistance to Atrial Natriuretic Peptide (ANP), a polypeptide that is released in order to reduce the blood pressure by decreasing the amount of water, sodium and fat in the circulatory system. It has also been suggested that intrarenal sodium retention is due to activation of the epithelial sodium channel in the collecting duct.

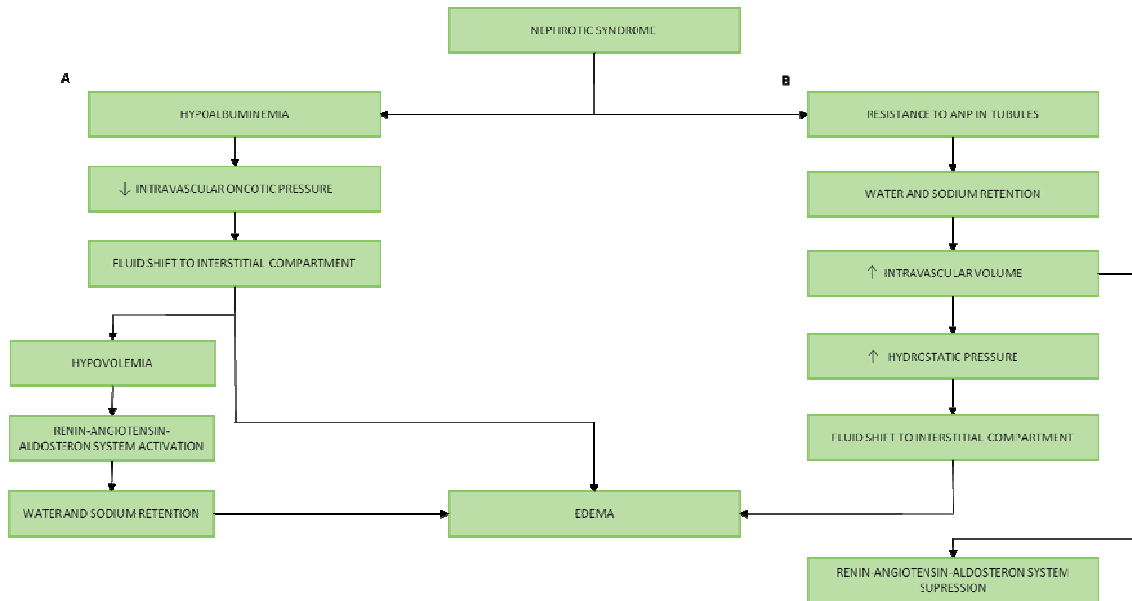

**Figure 8.** Pathophysiological mechanisms of edema formation. A) the underfilling hypothesis and B) the overfilling hypothesis (adapted from Hernando Avendaño 2008).

The finding that most NS patients have normal or elevated intravascular volume suggests that the overfilling hypothesis might prevail in most cases. However, in some children intravascular volume contraction is found. Of note, both hypotheses are not mutually exclusive and the volume status may depend on the stage of disease. It is possible that the underfilled state may be predominant in the acute setting, in which massive proteinuria causes rapid development of hypoalbuminemia and an abrupt drop in plasma oncotic pressure, whereas the overfilled state may be predominant in the chronic phase during which patients may have continuing sodium retention due to persistent low-grade hypoalbuminemia.

### 3.1.4. Hyperlipidemia

Hyperlipidemia is an abnormally high concentration of fats or lipids in blood. The most frequent lipid abnormality is hypercholesterolemia appearing in 85% of patients. The

hypertriglyceridemia is less frequent and only appears when the serum albumin is below 1-2 g/dl. Lipiduria, the excretion of fatty casts in urine, is also characteristic.

The pathogenesis of hyperlipidemia is multifactorial. Hypercholesterolemia seems to be the consequence of the decrease in the intravascular oncotic pressure that results in an increase in the hepatic synthesis of lipids and apolipoproteins. In addition, lipoproteins clearance is decreased due to the low level of tissue low density lipoproteins receptors. Hypertriglyceridemia is not due to the increase in triglycerides synthesis but a decrease in triglycerides catabolism. It is correlated with the albumin clearance but not with the decrease in the intravascular oncotic pressure.

The clinical significance of hyperlipidemia in NS is uncertain. Patients with NS and hyperlipidemia have an increased cardiovascular mortality, although these patients also have other cardiovascular risk factors. In animal models, hyperlipidemia accelerates the glomerular damage, promoting the inflammatory infiltrate and renal fibrosis.

## **3.2. COMPLICATIONS**

---

### **3.2.1. Thrombosis**

Renal-vein thrombosis and thromboembolic events in general constitute one of the most severe complications in NS. Its incidence is estimated to be 5-60% of patients being more frequent at the beginning of the disease. In addition, only 10% of patients with renal-vein thrombosis present with symptoms: flank pain, gross hematuria, increased renal size, and loss of renal function. In children, thromboses are more severe and in half of cases affect the arterial tree. In adults, arterial thrombosis is less common than venous thrombosis, but it is a serious complication causing important morbidity.

Severe hypoalbuminemia (less than 25 g/l), high proteinuria (more than 10 g/24h), high fibrinogen levels, low antithrombin III levels (less than 75% of normal), and hypovolemia are significantly associated with an excessive risk of thrombotic complication.

### **3.2.2. Acute renal insufficiency**

Acute renal insufficiency appears in patients treated with diuretics with severe hypoalbuminemia. Its main cause is intravascular volume depletion.

### 3.2.3. Endocrin alterations

NS alters the regulation of several endocrine systems due to the urinary loss of hormones or due to the change in their intravascular and extravascular distribution.

### 3.2.4. Infections

The risk of infections is increased in children. The most common and serious type of infection is primary bacterial peritonitis, which is estimated to have an incidence of 5% in NS children. Risk factors include low serum IgG levels due to urinary loss of IgG, abnormal T lymphocyte function, and decreased levels of factors B and D, resulting in a decreased ability to opsonize encapsulated bacteria. In addition, the administration of steroids and immunosuppressive drugs during relapses further increases the risk of infection.

## 3.3. ETIOLOGY OF NEPHROTIC SYNDROME

---

NS may be caused by a variety of glomerular and systemic diseases. Approximately 90% of the pediatric cases are primary or idiopathic but a small proportion of them are secondary to infectious agents and other glomerular and systemic diseases. Separation of these two categories is not always easy but it is important to decide the therapeutic approach. This thesis is only focused on the idiopathic nephrotic syndrome (INS).

INS can be associated with a variety of distinct clinic and pathological conditions largely dependent on the age at disease onset. The identification of the histological lesion may help to elucidate the pathogenesis of the disease.

### 3.3.1. Congenital Nephrotic syndrome of Finnish Type

Congenital nephrotic syndrome (CNS) appears within the first 3 months of life. CNS of Finnish type (CNF) represents the most severe form of NS. It was first described in Finland, where it has an incidence of 1/8200 births but it has been reported worldwide.

CNF is an autosomal recessive (AR) inherited disorder characterized by massive proteinuria even in utero, a large placenta, and characteristic microcystic dilatation of the proximal tubules. Mutations in *NPHS1* gene are the major cause of CNF, (explained in the next section) (Kestilä *et al.*, 1998).

A prenatal diagnosis of CNF is suspected as early as 16 to 18 weeks of gestation if elevated  $\alpha$ -fetoprotein levels are detected in the maternal serum or the amniotic fluid, reflecting fetal proteinuria. The abnormally large placenta (placental/weight ratio over 0.25) constricts the fetus likely causing premature delivery of the fetus with postural deformities. The child is typically small for the gestational age, with widened cranial fontanelles, a small low-bridged nose, and edema in approximately 25% of cases. Proteinuria is detectable at birth and it is extremely high ranging from 1 to 6 g/day. Initially, proteinuria is highly selective but it becomes poorly selective as the disease progresses. Heavy and constant proteinuria inevitably leads full-blown NS soon after birth with life-threatening edema, malnutrition, failure to thrive, and secondary complications. Microhematuria or signs of tubular dysfunction (aminoaciduria and glycosuria) may also be present. Renal function is usually normal at birth but it progressively declines reaching end-stage renal disease (ESRD) within the first 2 to 3 years of life. There is a high mortality within the first year due to the complications of NS, particularly infections and sepsis.

The histological lesions are detected more frequently after 3 months of age. The earliest manifestation is focal cystic dilatation of proximal tubules (Figure 10), although it is not present in all the cases, and/or an increase in mesangial cellularity and matrix, producing slight glomerular enlargement. As disease progresses, the characteristic lesions of CNF appear consisting of radial dilatations of the proximal tubules, mesangial proliferation and glomerular lesions of focal segmental sclerosis. Immunofluorescence does not detect immune deposits although as the disease progresses, IgM and complement C3 can be found. Effacement of podocytes foot processes and disappearance of the slit diaphragm are seen in electronic microscopy.

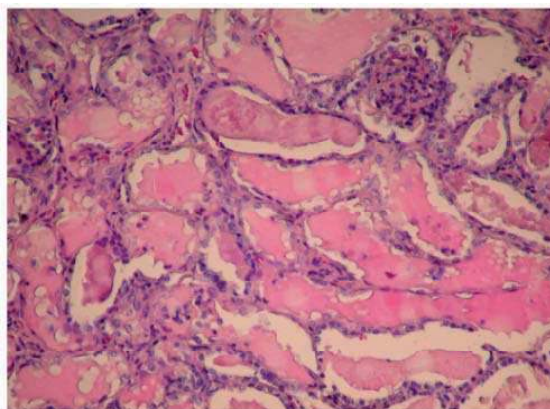

**Figure 10.** Histological lesions of congenital nephrotic syndrome of Finnish type at light microscopy. Hematoxylin eosin staining (Duicu *et al.*, 2009).

### 3.3.2. Diffuse mesangial sclerosis

Diffuse mesangial sclerosis (DMS) accounts for approximately 10% of CNS cases and one third of infantile NS cases (from 3 to 12 months) (Gbadegesin *et al.*, 2008).

DMS is characterized by onset of NS in the first year of life and rapid progression to ESRD, often within 1 to 3 months. This entity has been described as an isolated disorder or as part of syndromes with renal and extrarenal abnormalities such as Denys-Drash or Pierson Syndrome.

DMS is pathologically defined by mesangial expansion and sclerosis that evolves towards obliteration of the capillary lumen and contraction of the glomerular tuft (Figure 11). Immunofluorescence shows no glomerular immune deposits although nonspecific staining of the glomerular mesangium for IgM, C3, and C1q may be identified in some glomeruli. The major finding in electronic microscopy is extensive effacement of foot processes.

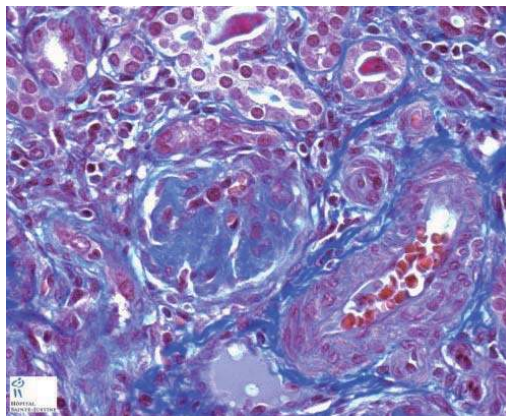

**Figure 11.** Histological lesions of diffuse mesangial sclerosis at light microscopy masson trichrome staining (from D'Agati *et al.*, 2005).

### 3.3.3. Minimal change disease

Minimal change disease (MCD) is the major histological finding in INS children accounting for more than 80%. The most frequent age at onset is 2-6 years (median 2.5) and is more common in males than females (Bansal 2014). In adults, MCD is responsible for around 15-20% of INS cases, there is a higher incidence in elderly than middle-aged adults and the incidence is equal between both genders (Cameron 1996; Korbet *et al.*, 1988; Haas *et al.*, 1997).

MCD virtually always manifests as NS at the onset, thus, the predominant findings are heavy proteinuria, hypoalbuminemia, edema and elevated serum cholesterol. Proteinuria in MCD is usually highly selective, consisting predominantly of albumin. Most children with MCD



do not have evidence of renal insufficiency, hematuria, or hypertension. This entity is highly steroid responsive but in some cases may follow a remitting and relapsing course. Progression to ESRD is not part of the natural history of MCD.

MCD is pathologically characterized by minimal or no glomerular alterations on light microscopy (Figure 12). The “minimal” findings include podocyte swelling and mild mesangial expansion. Immunofluorescence does not detect glomerular immune deposits although in a minority of cases, there may be weak mesangial positivity for immunoglobulin IgM, with or without C3. Electronic microscopy shows extensive effacement of foot processes in the absence of other abnormalities of the peripheral capillary walls.

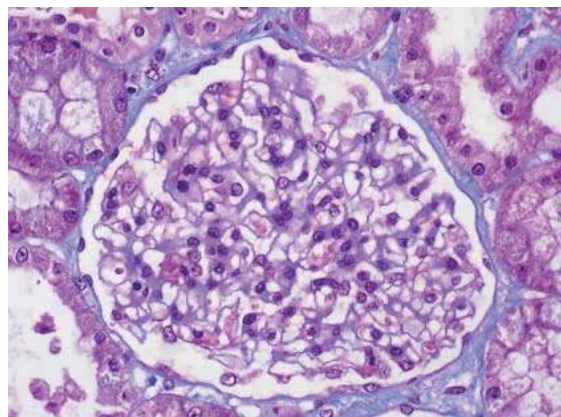

**Figure 12.** Histological lesions of minimal change disease at light microscopy. Masson trichrome staining (from kidney pathology website).

### 3.3.4. Focal segmental glomerulosclerosis

Focal segmental glomerulosclerosis (FSGS) is one of the most frequent patterns of injury found in INS accounting for approximately 10% of children, 20-50% of adolescents and around 20-30% of adults (Hogg *et al.*, 2007; Cameron 1996; Korbet *et al.*, 1988; Haas *et al.*, 1997). FSGS lesions can occur as a result of many causes, including circulating factors, mutations in podocyte genes or be secondary to drugs, infections or maladaptive responses to nephron loss (Bose & Cattran 2014).

Ethnicity plays important roles in the incidence of FSGS being 3-7 times higher in young black men as compared with whites (Freedman *et al.*, 2009). The reported annual incidence rates for FSGS is 5 cases per million population in whites, compared with 24 cases per million population in African Americans. This increased incidence is partly explained by genetic risk factors in 2 important podocyte function proteins: nonmuscle myosin heavy chain-9 (MYH9) and apolipoprotein L1 (APOL1). Three polymorphisms in *MYH9* gene were reported to confer



risk for idiopathic FSGS and hypertensive ESRD among blacks in AR model (Kopp *et al.*, 2008). Further investigation revealed two variants, called G1 and G2, in the last exon of the neighboring gene *APOL1* that had stronger association with FSGS and were under strong selection only in Africa (Genovese *et al.*, 2010).

Proteinuria is a defining feature of FSGS, typically accompanied by hypoalbuminemia, hypercholesterolemia, and edema. Approximately 75-90% of children and 50-60% of adults with FSGS have NS at presentation (D'Agati *et al.*, 2011). FSGS is associated with a poor response to corticosteroid treatment (only about 50% of patients respond to therapy). It is usually a progressive disorder with <5% spontaneous remission and a 50% ESRD rate over a period of 5-8 years from the time of the renal biopsy in patients that are either unresponsive to treatment or not treated (Bose & Cattran 2014). Black race, increased degrees of proteinuria, and renal insufficiency are associated with a worse outcome. Approximately 40% of patients who undergo kidney transplantation develop recurrence of the disease in the allograft (D'Agati *et al.*, 2011).

FSGS is pathologically defined as glomerular sclerosis involving a subset of glomeruli (focal) and a portion of the glomerular tuft (segmental) (Figure 13). Because juxtamedullary nephrons are often affected first, adequate glomerular sampling is needed to identify the diagnostic lesions. As the disease progresses, a more diffuse and global pattern of sclerosis evolves and tubular atrophy and interstitial fibrosis develop. Immunofluorescence typically reveals coarse segmental staining for IgM and C3 entrapped in areas of hyalinosis. On electronic microscopy, the major finding is extensive effacement of the foot processes without other abnormalities in the GBM. There are several FSGS variants based on the pathologic findings, from best to worst prognosis: tip, FSGS not otherwise specified, cellular, collapsing, and perihilar, being the most common FSGS not otherwise specified. Also, increased severity of interstitial fibrosis and tubular atrophy in biopsy specimens are associated with worse outcome.

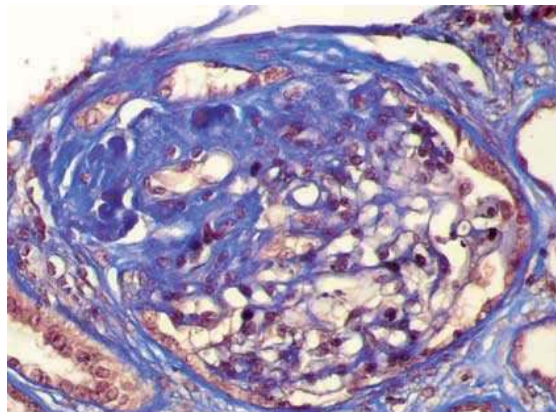

Figure 13: Histological lesions of focal segmental glomerulosclerosis at light microscopy. 400x, masson trichrome staining (from kidney pathology website).

### 3.3.5. Membranous nephropathy

Membranous nephropathy (MN) is one of the most common forms of NS in adults, accounting for about 20% of cases (Glasscock 2010). It comprises less than 2% of all idiopathic NS cases in children under the age of 5 years, but its incidence increases progressively through adolescence and into adulthood with a peak incidence in individuals aged 30-50 years. The disease incidence is also influenced by sex being more common in males than females (sex ratio 2:1). This condition is idiopathic in approximately 70-80% of cases, whereas the remaining are secondary to a variety of autoimmune, infectious, neoplastic, and other systemic diseases, or following exposure to certain medications (Glasscock 2010).

The predominant clinical presentation of patients with MN is NS, occurring in 60-80% of them. The remaining patients present with subnephrotic proteinuria, often asymptomatic that may be detected as an incidental finding during a routine medical examination, and about 60% of them will progress to full NS (Fervenza *et al.*, 2008; Hladunewich *et al.*, 2009). Microscopic hematuria occurs in up to 50% of patients with MN, but red blood cells casts and macroscopic hematuria are rare (Wasserstein 1997). About 80% of patients with MN have normal blood pressure and glomerular filtration rate at presentation. Acute renal failure is uncommon (Ronco & Debiec 2015).

IMN natural history follows three major clinical courses: spontaneous remission, stable but persistent proteinuria, or progression to ESRD. Spontaneous remission occurs in approximately one third of patients, usually within the first two years after presentation (Polanco *et al.*, 2010; Polanco *et al.*, 2012). The other two thirds of patients can be divided equally into those with persistent proteinuria who will maintain normal renal function long term and those patients who will progress to renal failure despite immunosuppressive therapy (Glasscock 2003). MN is the second or third leading cause of ESRD in patients with primary glomerulonephritis and the glomerulopathy that recurs most frequently after kidney transplantation (in about 40% of cases) and threatens graft function (Ronco & Debiec 2015).

MN is pathologically defined as a capillary wall thickening, normal cellularity, positive IgG and C3 staining along capillary walls on immunofluorescence, and accumulation of immune deposits on the outer aspect of the GBM on electron microscopy called spikes (Figure 14).

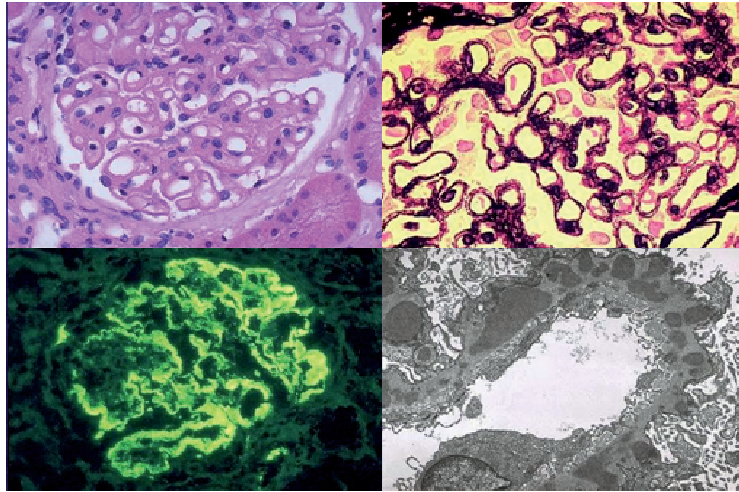

**Figure 14:** Histological lesions of membranous nephropathy. A) Hematoxylin eosin staining at light microscopy: capillary loops are thickened and prominent but cellularity is not increased. B) Silver staining at light microscopy: there are characteristic “spikes” of glomerular basement membrane between the immune deposits. C) Immunofluorescence micrograph: subepithelial deposits of mainly IgG and complement appear in a diffuse granular pattern in the glomerular basement membrane. D) Electron microscopy: electron dense immune deposits are seen scattered within the thickened glomerular basement membrane (renal pathology website).

### 3.4. TREATMENT

---

INS treatment requires a global therapeutic approach to counteract the glomerular lesion but also the derived systemic complications. General measures to treat proteinuria and edema are common in most patients, whereas specific treatment depends on the age at onset and/or the histological lesion.

Renal biopsy is considered mandatory in adult patients to distinguish among the different renal lesions because the treatment approach differs among the different entities. In children the renal biopsy is only performed when the NS is steroid resistant as most of patients are respondent.

#### 3.4.1. General management

Proteinuria is treated with renin-angiotensin-aldosterone system (RAAS) blockers including both, angiotensin-converting-enzyme inhibitors (ACEi) and angiotensin II receptor antagonists (AIIRA) as they have a synergic effect. These drugs avoid the formation and action of angiotensin II, a hormone that has a vasoconstrictive action and increases blood pressure. The vasodilation of the glomerular efferent arteriole decreases the intraglomerular pressure and therefore decreases protein leakage.

General measures to control edema include salt restriction, lying in supine position, and use of diuretics drugs. Moderate exercise, a low cholesterol diet, hydroximetilglutaril-CoA reductase inhibitors, and weight lost in obese patients are recommended to reduce hiperlipidemia. Hygienic, dietetic and pharmacological measures are needed to counteract the high morbidity and mortality associated with NS and its complications.

### **3.4.2. Treatment in CNS**

The goals of therapy during the first months are to control edema and possible uremia, prevent and treat complications such as infections and thromboses, and provide optimal nutrition so that the child grows and develops as normally as possible.

CNS patients are resistant to corticosteroids and immunosuppressive therapy, therefore the only curative approach is renal transplantation. Bilateral nephrectomy and dialysis may be necessary to avoid the complications of NS.

### **3.4.3. Treatment in children and FSGS/MCD adults**

#### **3.4.3.1. Corticosteroid therapy**

Corticosteroids are the first-line treatment for most INS. Children presenting with INS are treated empirically with corticosteroids because there is a high incidence of MCD, which is associated with a high rate of steroid responsive. A complete remission is considered if proteinuria  $< 100\text{mg}/\text{m}^2/\text{day}$  or  $< 1+$  on urine dipstick for 3 consecutive days, and urine protein/creatinine ratio  $< 20\text{ mg}/\text{mmol}$ . Partial remission consists of a proteinuria of  $0.1\text{-}1\text{ g}/\text{m}^2/\text{day}$  and absolute urine protein/creatinine ratio between 20 and 200  $\text{mg}/\text{mmol}$  (Trautmann *et al.*, 2015).

Adults with FSGS or MCD as renal lesion are also initially treated with corticosteroids. A complete remission is defined by proteinuria  $< 0.3\text{ g}/\text{day}$  and normalization of serum albumin to at least  $3.5\text{g}/\text{dl}$ . Partial remission is considered if proteinuria  $0.3\text{-}3.5\text{ g}/\text{day}$  with a reduction in proteinuria by at least 50% from the baseline.

Based on patients' response to steroid therapy, INS can be divided into:

- Steroid-Sensitive Nephrotic Syndrome (SSNS): patients who achieve remission in response to corticosteroid treatment alone. Approximately 80-90% of these patients have one or more relapses, but they mostly continue to respond to corticosteroids throughout their subsequent course and the long-term prognosis, including the maintenance of normal kidney function, is good. The most frequent renal histological lesion of SSNS is MCD.
- Steroid-Dependent Nephrotic Syndrome (SDNS): patients that initially respond to corticosteroid treatment by achieving complete remission but develop a relapse either while still receiving steroids at lower doses or within 2 weeks of discontinuation of treatment following a steroid taper. Such patients typically require continued low-dose treatment with steroids to prevent development of relapse.
- Steroid-Resistant Nephrotic Syndrome (SRNS): Patients who fail to achieve remission after 8 weeks (children) or >4 months (adults) of corticosteroid treatment. The most frequent renal histological lesions of SRNS are FSGS or DMS. Steroid resistant MCD adults should be re-evaluated for other causes of NS.

It is estimated that about 80% of children and 60% of adults with INS respond to steroid therapy with complete resolution of proteinuria and edema. Among this steroid sensitive group, the clinical course is variable, with up to 60% having frequent relapses or becoming dependent on steroid therapy to maintain them in remission. The remaining 20% of children and 40% of adults with INS do not achieve a sustained remission after standardized corticosteroid therapy (Arbeitsgemeinschaft für Pädiatrische 1988; Antignac 2002; Troyanov *et al.*, 2005).

#### **3.4.3.2. Immunosuppressive therapy**

Immunosuppressive therapy is considered in patients with SRNS, frequent relapses or steroid dependency. There are different immunosuppressive therapies available and different therapeutic schemes depending on the age at onset and/or the histological lesion (reviewed in KDIGO guidelines (Glomerulonephritis Work Group 2012)).

#### **3.4.4. Treatment in MN**

Spontaneous remission is a well-known characteristic of MN occurring in approximately one third of patients, but it may be delayed for as long as 18-24 months (Polanco *et al.*, 2010).

Thus, the initial approach in MN patients consists of a 6-month observational period, in which only antiproteinuric agents are given. Patients with persistent proteinuria and no decline after 6 months are treated with immunosuppressors according to KDIGO guidelines (Glomerulonephritis Work Group 2012).

IMN patients presenting with non-nephrotic proteinuria typically only receive ACEi and AIIRA and they have a very favorable long-term prognosis (Hladunewich *et al.*, 2009; Ponticelli & Glassock 2014). However, a delay in immunosuppressive treatment in patients presenting with NS would expose them to the complications of NS (van den Brand *et al.*, 2012). In these patients, controversy exists regarding the proper timing of immunosuppression and the best therapeutic regimen, due to the low therapeutic index of immunosuppressive drugs and their side effects (Remuzzi *et al.*, 2002; Perna *et al.*, 2004; Glassock 2004; du Buf-Vereijken *et al.*, 2005). A number of clinicians propose to restrict immunosuppressive therapy to patients with sustained heavy proteinuria or in the face of worsening renal function (Cattran 2005).

Several markers of disease progression help clinicians to predict the clinical outcome of the disease. Predictors of spontaneous remission are baseline proteinuria less than 8 g/day, female sex, age younger than 50 years old and preserved renal function at presentation (Cattran 2005). However, even in patients with large proteinuria, spontaneous remission can occur in up to 20-25% of them (Polanco *et al.*, 2010).

The Toronto Risk Score is calculated by a validated algorithm that correctly identifies patients at risk of disease progression with 85-90% accuracy. This score is based on the level of proteinuria during a 6-month period of maximum proteinuria, creatinine clearance at the start of that period, and the change in creatinine clearance over the course of those 6 months. According to the score obtained, patients are grouped into low-, middle-, and high-risk for progression and a different treatment approach is indicated (Figure 15) (Pei *et al.*, 1992; Cattran *et al.*, 1997). The main disadvantage of this model is that an observational period of at least 6 months (or more if the period of maximum proteinuria does not correspond with the onset of the disease) is needed to calculate the score, which prolongs patient exposure to risks associated with NS.

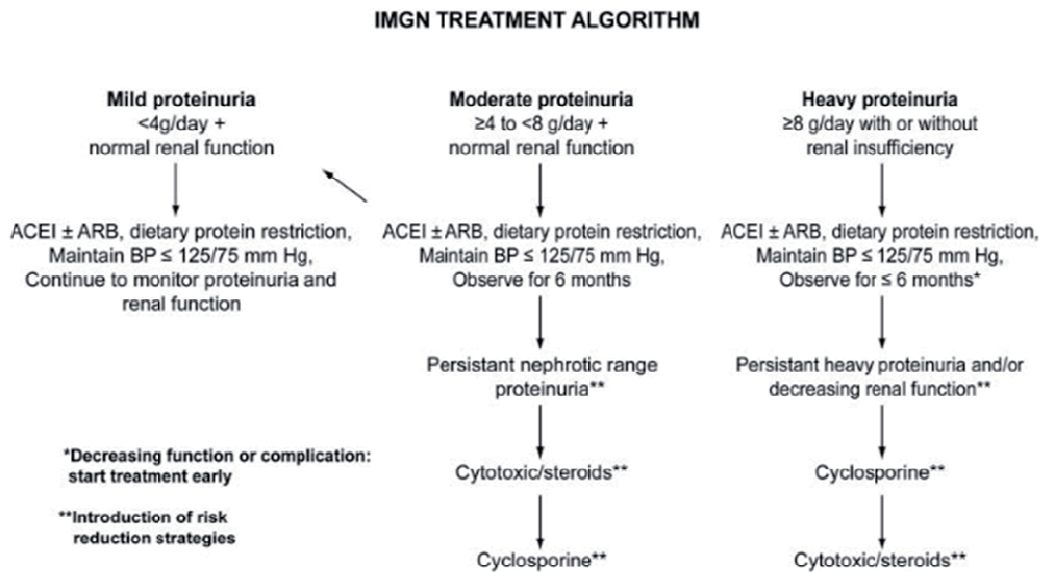

**Figure 15.** A treatment algorithm that combines the predictive factors and best evidence for conservative and then immunosuppressive treatment (Cattran 2005).

Measurement of the urinary excretion of  $\beta$ 2-microglobulin and  $\alpha$ 1-microglobulin in spot urine samples was also shown to accurately predict progressive loss of kidney function (Branten *et al.*, 2005; Hofstra *et al.*, 2008). Van den Brand *et al.* compared the prognostic value of the Toronto Risk score with the urinary low-molecular weight proteins ( $\beta$ 2-microglobulin and  $\alpha$ 1-microglobulin) and showed that both prognostic methods had high sensitivity and specificity with no significant differences between them. However, urinary markers have the advantage that the prognosis can be established with a single measurement (van den Brand *et al.*, 2012). The clinical complexity of the disease suggests that a combination of prognostic markers would be the best option for prediction of clinical outcome.

#### 4. PATHOGENESIS OF IDIOPATHIC NEPHROTIC SYNDROME

INS is due to the development of structural and functional defects in the GFB, resulting in its inability to restrict urinary loss of protein. Podocyte foot process effacement is the invariable feature observed not only in NS patients but also in all proteinuric glomerular diseases, and it can result from several triggers including immune causes and genetic abnormalities (Deegens *et al.*, 2008). Briefly, idiopathic MN (IMN) is considered an organ-specific autoimmune disease. SSNS and SDNS patients, generally presenting with MCD or FSGS on renal biopsy, are considered to be caused by a T-cell dependent circulating factor. Finally, in CNS and SRNS patients, the latter usually showing FSGS or DMS as histological lesion, a genetic defect is considered to be responsible for the disease.



## 4.1. IMMUNE COMPLEXES DEPOSITION: MN

---

MN is an immunologically mediated disease characterized by the deposition of immune complexes in the subepithelial space, which causes a thickening of the GBM. The immune deposits consist of several components, including IgG, antigens, and the membrane attack complex. IgG4 is usually the most prominent IgG subclass deposited in idiopathic IMN, although variable amounts of IgG1 are also associated with immune deposits; by contrast, deposition of IgG1, IgG2 and IgG3 exceeds deposition of IgG4 in secondary MN (Imai *et al.*, 1997; Kuroki *et al.*, 2002; Ohtani *et al.*, 2004; Segawa *et al.*, 2010).

In the past 10 years, great progress has been made in the understanding of the molecular pathomechanisms of human MN inspired by studies of experimental models. Studies on Heymann nephritis rats led to the concept that a podocyte antigen, megalin, could serve as a target of circulating antibodies leading to the *in situ* formation of immune complexes (Figure 16) (Heymann *et al.*, 1959; Kerjaschki & Farquhar 1982). However, megalin is neither expressed in human podocytes nor detected in the subepithelial deposits in patients with MN (Herrmann *et al.*, 2012).

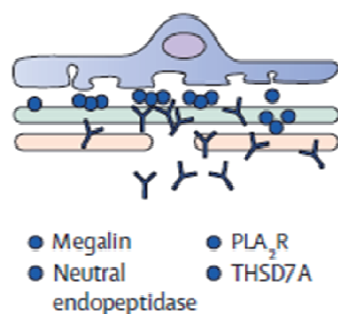

**Figure 16.** *In-situ* formation of immune deposits. Circulating antibodies bind to an endogenous podocyte antigen (adapted from Ronco & Debiec 2015).

In humans, a number of podocyte antigens have been identified (Figure 16). Antibodies that target podocyte antigens accumulate as immune deposits leading to complement activation, functional impairment of the GFB and proteinuria (Ronco & Debiec 2012).

Circulating antibodies against neutral endopeptidase (NEP) were identified in a child with neonatal MN (Debiec *et al.*, 2002). NEP is a membrane-bound enzyme that can digest biologically active peptides (Turner *et al.*, 2001). The mother was NEP deficient due to mutations on *MME* gene, which codifies for a membrane metallo-endopeptidase. She became alloimmunized to the paternally inherited NEP antigen expressed in the placenta during pregnancy and transplacentally transferred NEP antibodies to the child causing MN. The fact



that rabbits injected with the IgG fraction from the mother also developed MN and proteinuria was an additional proof that the disease was related to circulating anti-NEP antibodies (Debiec *et al.*, 2002). In the five cases with alloimmune neonatal MN identified so far, the mothers were NEP deficient due to homozygous truncating deletion in exon 7 or compound heterozygote for this mutation and a second mutation in exon 15 of the *MME* gene (Debiec *et al.*, 2004; Vivarelli *et al.*, 2015). This finding provided the proof of concept that a podocyte antigen could be responsible for human MN, as is the case for megalin in rats, and laid the foundation for the identification of podocyte autoantigens in adults with IMN.

The identification of antibodies to the M-type phospholipase A2 receptor (PLA2R1) in about 70% of patients with IMN indicated that PLA2R1 is the major target antigen in this disease (Beck *et al.*, 2009). Recently, Tomas *et al.* detected circulating antibodies to thrombospondin type-1 domain-containing protein 7A (THSD7A) in 8-14% of patients negative for anti-PLA2R1, identifying THSD7A as the second major autoantigen in IMN (Tomas *et al.*, 2014). PLA2R1 and THSD7A proteins are detected in normal human podocytes, and both antigens colocalize with IgG4 in subepithelial deposits. Both proteins have quite similar structural and biochemical properties consisting of a large extracellular region with multiple and repeated disulfide-bonded and N-glycosylated domains. IgG4 antibodies against these antigens were present in sera from patients with IMN but not in the serum of healthy controls, or patients with secondary MN. Furthermore, IgG eluted from biopsy samples reacted with recombinant PLA2R or THSD7A. Autoantibodies to both proteins recognize their target antigens only under non-reducing conditions. Interestingly, patients with IMN have an autoimmune response against either PLA2R or THSD7A, but not both. This finding suggests PLA2R-associated and THSD7A-associated MN are two separate entities (Beck *et al.*, 2009; Tomas *et al.*, 2014).

Antibodies against the cytosolic proteins superoxide dismutase 2 (SOD2), aldose reductase, and  $\alpha$ -enolase were identified in both, serum and glomeruli of patients with IMN (Prunotto *et al.*, 2010; Bruschi *et al.*, 2011). These proteins are not present or minimally expressed on normal podocyte membranes but are “neo-expressed” in glomeruli of patients with IMN. Mechanisms of translocation of these intracellular molecules have been proposed to explain the development of these autoantibodies. *In vitro* studies have shown that SOD2 can be induced by oxidative stress such as exposure to hydrogen peroxide. Anti- $\alpha$ -enolase antibodies are not specific for MN as they have been detected in a wide range of autoimmune diseases

without glomerular involvement and in healthy individuals. The pathogenic role of these antibodies remains uncertain.

There are still 15-25% of IMN cases in which no target antigen has been identified indicating that there may be as-yet unidentified antigens or that these patients have been wrongly classified as idiopathic owing to an undetected secondary cause of the disease (Tomas *et al.*, 2014).

It has long been known that IMN is associated with certain HLA class II immune response genes (Klouda *et al.*, 1979; Le Petit *et al.*, 1982; Vaughan *et al.*, 1989; Ogahara *et al.*, 1992; Chevrier *et al.*, 1997). The single-nucleotide polymorphism (SNP) rs35771982 in *PLA2R1* gene was associated with IMN in Korean and Taiwanese cohorts (Liu *et al.*, 2010; Kim *et al.*, 2011). Genome-wide association studies have reported highly significant association of an *HLA-DQA1* allele on chromosome 6p21 and a *PLA2R1* allele on chromosome 2q24 with IMN in white European patients. Interestingly, carrying the risk alleles of both genes had an additive effect, thus, for a person who is homozygous for both risk alleles the odds ratio for developing IMN is close to 80, compared to individuals homozygous for the protective alleles. These findings suggest that genetic background plays a significant role in the predisposition of the primary MN (Stanescu *et al.*, 2011).

#### 4.2. T CELL DEPENDENT CIRCULATING FACTOR: SSNS AND SDNS

---

An underlying immune defect is supposed to cause SSNS, SDNS and the subset of SRNS that respond to immunosuppressive agents and/or relapse after kidney transplantation. These patients generally present with MCD or FSGS on renal biopsy.

In 1954, Gentili *et al.* hypothesized that INS was caused by a circulating factor, based on daring experiments in which they administered plasma from infants with INS to non-nephrotic children and observed a minimal increase in proteinuria (Gentili *et al.*, 1954). In 1974, Shalhoub suggested that INS was mediated by a T-cell-dependent circulating factor that would affect glomerular permeability (Shalhoub 1974).

Clinical evidence for the existence of a circulating permeability factor in idiopathic MCD was based on the responsiveness of most forms of primary MCD to corticosteroids, alkylating agents, calcineurin inhibitors, and mycophenolate mofetil, all of which are known inhibitors of T lymphocyte function (Gbadegesin & Smoyer 2008). Regarding FSGS, the best evidence for

the existence of circulating permeability factor came from clinical observations of proteinuria and FSGS recurrence after kidney transplantation (Hoyer *et al.*, 1972). Additional evidence came from studies reporting remission of proteinuria by plasma exchange or immunoadsorption, especially if instituted early in the course of recurrent disease (Dantal *et al.*, 1994; Artero *et al.*, 1994; Deegens *et al.*, 2004). Moreover, serum or plasma from patients with recurrent FSGS induced proteinuria in rats and increased albumin permeability in isolated glomeruli. In the past four decades, many investigators have searched the responsible factors, thus far with little success (Maas *et al.*, 2014).

In 2011, soluble urokinase plasminogen activator receptor (suPAR) was proposed to be the permeability factor causing FSGS. suPAR is a 20-50 kD protein with three homologous domains produced by cleavage and release of membrane bound urokinase plasminogen activator receptor (uPAR) (Behrendt *et al.*, 1990). In cultured podocytes and in animal models, increased podocyte uPAR expression resulted in foot process effacement and actin cytoskeleton rearrangement due to the activation of integrin  $\beta 3$ , one of the main proteins anchoring podocytes to the GBM (Wei *et al.*, 2011).

In humans, a significantly increased serum suPAR levels was found in patients with FSGS compared to healthy and disease controls but these relationships disappeared when adjusting for renal function. Of note, the ELISA test used in these studies did not discern between full-length glycosylated suPAR from fragments. In addition, both short-term and prolonged administration of recombinant suPAR in mice did induce neither albuminuria, nor foot processes effacement. Based on these findings, full-length suPAR is not the cause of FSGS. However, the specific pathologic type of suPAR could be unglycosylated and/or suPAR fragments, likely explaining the negative results in ELISA experiments and with recombinant suPAR (Deegens & Wetzels 2014; Reiser *et al.*, 2014).

### 4.3. GENETIC CAUSE: SRNS

---

Inherited structural defects of GFB are responsible of a proportion of SRNS patients. These patients are mostly resistant to immunosuppressive agents, almost invariably progress to ESRD and do no relapse after renal transplantation (Machuca, Benoit, *et al.*, 2009).

Mutations in more than 30 genes have been associated with SRNS to date. Most of these mutations are in podocyte genes and disrupt podocyte function either through slit diaphragm disassembly, damaging cell architecture or metabolism, disturbing cell-matrix interactions,

and/or impeding signaling pathways. Syndromic forms of NS are caused by inherited defects in structures nonspecific to the kidney, such as mitochondrial and lysosomal organelles that may also lead to podocyte dysfunction. Mutations in a few genes encoding GBM proteins have also been associated with NS (Figure 17) (Vivante & Hildebrandt 2016).

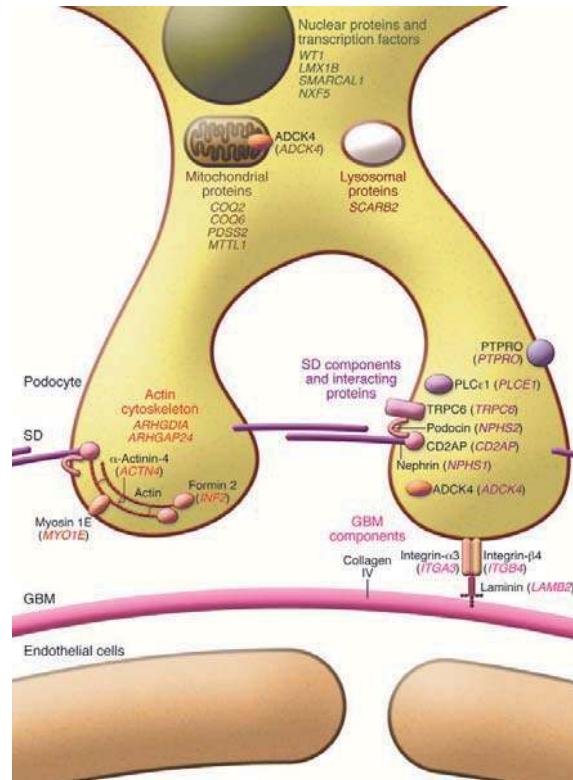

**Figure 17.** Genetic causes of SRNS. Most of the mutated proteins reside in the podocyte (Malaga-Dieguez & Susztak 2013).

Inherited genetic defects in all these genes only explained approximately 30% of SRNS cases consisting of 70% of familial and 15-25% of sporadic SRNS cases (Santín, Bullich, *et al.*, 2011; McCarthy *et al.*, 2013). The percentage of patients with mutations decreases as the age at onset increases (Figure 18). Mutation screening of the largest cohort of SRNS patients studied so far, consisting of 2016 patients (1783 families), identified a genetic disease cause in 29.5% of cases. Specifically, mutations were identified in 69.4% of congenital cases (onset from 0-3 months), 49.7% of infantile cases (from 4 to 12 months), 25.3% of young children cases (from 13 months to 6 years), 17.8% of older children cases (from 7 to 12 years), 10.8% of adolescents (from 13-18 years) and 21.4% of young adults (from 19 to 25 years). In this study the most frequent mutated gene was *NPHS2* accounting for 49.8% of patients, followed by *WT1* in 17.3% of patients and *NPHS1* in 14.8% of patients. Most of the remaining genes identified are rare mutations involving a few families (Sadowski *et al.*, 2014).

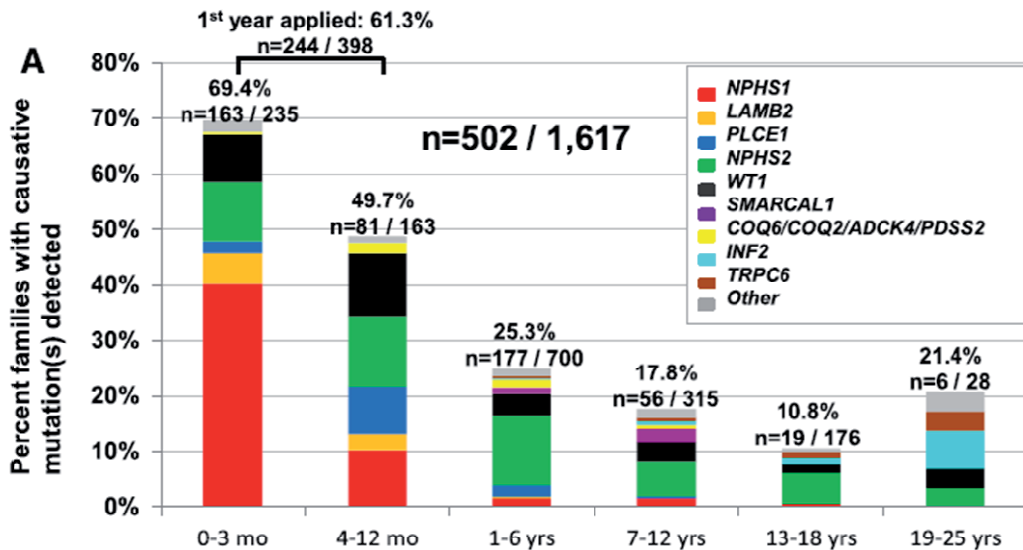

**Figure 18.** Percentage of patients with causative mutation detected in one of the 21-SRNS genes analyzed in relation to age of onset of proteinuria (Sadowski *et al.*, 2014).

Mutation screening of the most frequently mutated genes in large cohorts revealed that the distribution of the causative gene depends on the age at onset, the familial/sporadic status, and the mode of inheritance. Based on these criteria, our group proposed a genetic testing approach in children and adults with SRNS (Figure 19). Mutations in *NPHS1* are responsible for most of the CNF patients but CNS is genetically heterogeneous in non-Finnish populations. Most patients in whom the disease began in the first week of life had mutations in the *NPHS1* gene, whereas mutations in *NPHS2* were the main genetic cause of CNS in patient in whom NS began more than 1 month after birth (Machuca *et al.*, 2010). The most frequent cause of infantile and childhood onset SRNS (from 13 months to 12 years) are *NPHS2* mutations although *NPHS1* mutations are also found. *WT1*-related SRNS is mostly detected in sporadic patients with an onset ranging from congenital to childhood. In adolescence and adult onset patients the p.R229Q variant in compound heterozygosity with a pathogenic mutation in *NPHS2* gene and *INF2* mutations are the most frequent causes of the disease (Santín, Bullich, *et al.*, 2011).

Most of the genes involved in pediatric SRNS follow an AR inheritance, including mutations in *NPHS1*, *NPHS2*, and *PLCE1* among others. The exception is *WT1*-related SRNS which follows and autosomal dominant (AD) pattern. The AD forms of SRNS (*INF2*, *TRPC6* among others) are generally characterized by a milder disease course with typically adolescent (from 13 to 18 years) or adult (>18 years) onset, variable degrees of proteinuria, and slow progression to ESRD (Conlon *et al.*, 1995; Rana *et al.*, 2003). Since most patients do not exhibit full-blown NS, these forms are usually referred to as AD FSGS (Boyer *et al.*, 2015).

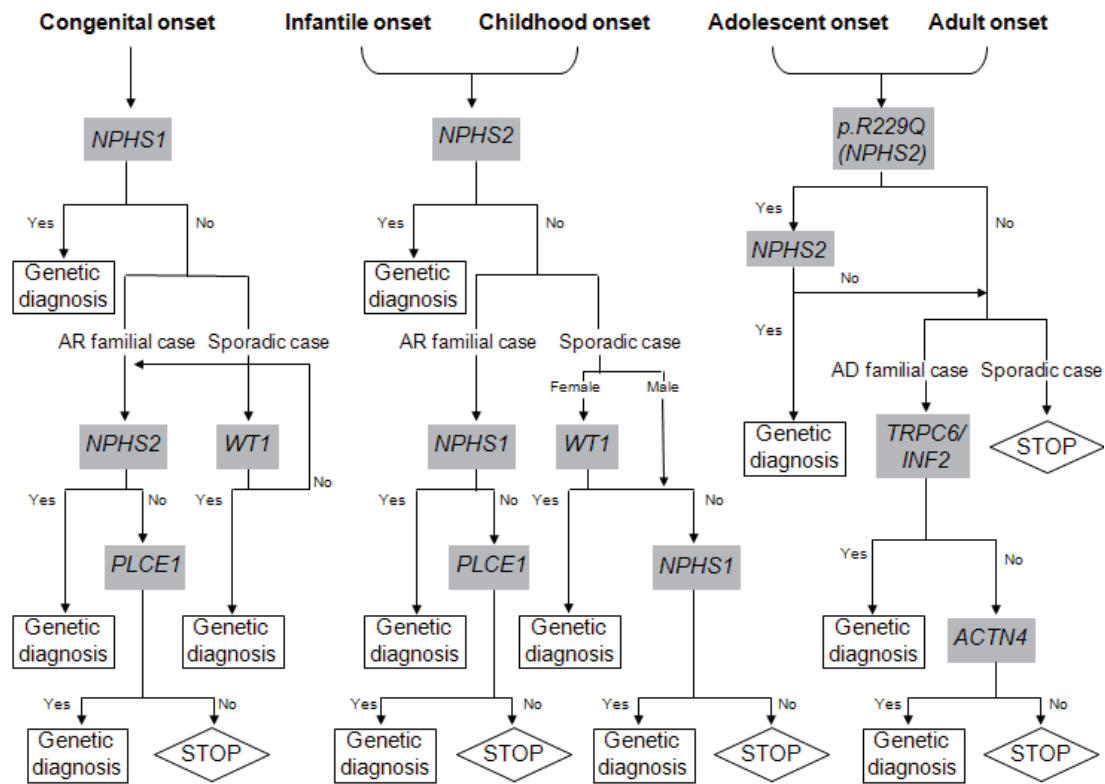

**Figure 19.** Genetic approach in children and adults with SRNS (Santín, Bullich, *et al.*, 2011).

Of note, the renal histological lesion is not considered in our genetic testing algorithm because in most children renal biopsy is not performed. In addition, the renal histological lesion is not specific as most cases present with FSGS independently of the mutated gene. The exception is DMS lesion, which is suggestive of *WT1* or *PLCE1* mutations.

The high genetic heterogeneity and phenotypic variability of SRNS hampers the genetic diagnosis of the disease. The advent of next-generation sequencing technologies has revolutionized the genetics field facilitating the identification of new genes associated with SRNS and providing the tools to deal with the high genetic heterogeneity of SRNS. However, there are still a large proportion of SRNS patients with no underlying genetic defect found; therefore, numerous further genes are expected to be identified as causative of SRNS.

## 5. GENETICS OF SRNS

### 5.1. Autosomal recessive isolated SRNS and FSGS

**Table1.** Genes causative of autosomal recessive isolated SRNS and FSGS.

Gene	Reference	MOI	Typical age at diagnosis of proteinuria/NS	Typical histology	Age at ESRD	Number of families (patients) published
<b><i>NPHS1</i></b>	Kestila M <i>et al.</i> , 1998	AR	0-10 years	CNF, MCD, FSGS	7 months – 15 years	> 270 (>300)
<b><i>NPHS2</i></b>	Boute N <i>et al.</i> , 2000	AR	0-40 years	MCD, FSGS	2-50 years	>600 (>850)
<b><i>PLCE1</i></b>	Hinkes B <i>et al.</i> , 2006	AR	0-8 years	DMS, FSGS	5 months – 12 years	50 (71)
<b><i>CD2AP</i></b>	Lowik MM <i>et al.</i> , 2007	AR-(AD)	10 months	FSGS	3 years	1 (1)*
<b><i>CUBN</i></b>	Ovunc <i>et al.</i> , 2011	AR	4-5 years	ND	ND	1 (2)
<b><i>PTPRO</i></b>	Ozaltin F <i>et al.</i> , 2011	AR	5-14 years	MCD, FSGS	18 years	2 (5)
<b><i>MYO1E</i></b>	Sanna-Cherchi S <i>et al.</i> , 2011	AR	2 months-9 years	FSGS	6 - >15 years	10 (14)
<b><i>CFH</i></b>	Sethi <i>et al.</i> , 2012	AR	childhood	FSGS	ND	1 (1)
<b><i>ARHGDI1</i></b>	Gupta IR <i>et al.</i> , 2013	AR	2-3 weeks	DMS	3 months	3 (6)
<b><i>ADCK4</i></b>	Ashraf S <i>et al.</i> , 2013	AR	<1-21 years	FSGS	7-23 years	20 (41)
<b><i>TTC21B</i></b>	Cong EH <i>et al.</i> , 2014	AR	9-30 years	FSGS	12-35 years	7 (13)
<b><i>EMP2</i></b>	Gee <i>et al.</i> , 2014	AR	3 years	MCD	ND	1(1)**
<b><i>CRB2</i></b>	Ebarasi L <i>et al.</i> , 2015	AR	9 months-6 years	FSGS	NA	5 (4)
<b><i>NUP107</i></b>	Miyake <i>et al.</i> , 2015	AR	2-11 years	FSGS	4-12 years	5 (9)
<b><i>NUP93</i></b>	Braun <i>et al.</i> , 2016	AR	1-6 years	FSGS	1-11 years	6 (7)

Abbreviations: AD, autosomal dominant; AR, autosomal recessive, CNF, congenital nephrotic syndrome of Finnish type; DMS, diffuse mesangial sclerosis; ESRD, end-stage renal disease; FSGS, focal segmental glomerulosclerosis; MCD, minimal change disease; MOI, mode of inheritance; ND, no data; NS, nephrotic syndrome

\*only the AR patient is considered

\*\*Mutations in this gene in 3 families (4 patients) with steroid-sensitive NS have been reported.



### 5.1.1. *NPHS1* gene

The *NPHS1* gene spans 26 kb on chromosome 19q13 and contains 29 exons (Kestilä *et al.*, 1994). *NPHS1* encodes nephrin, the major structural protein of the GFB. Nephrin is a transmembrane adhesion protein of 1241 amino acids and approximately 135 kDa that belongs to the immunoglobulin superfamily. This protein contains 8 C2-type Ig-like domains and a fibronectin type III repeat in the extracellular regions, a single transmembrane domain, and a cytosolic C-terminal end. The extracellular domain of nephrin forms homodimers and heterodimers with NEPH1. Nephrin-NEPH1 interactions control nephrin signaling, glomerular permeability and podocyte cell polarity (Figure 20) (Garg *et al.*, 2007; Liu *et al.*, 2003; Hartleben *et al.*, 2008).

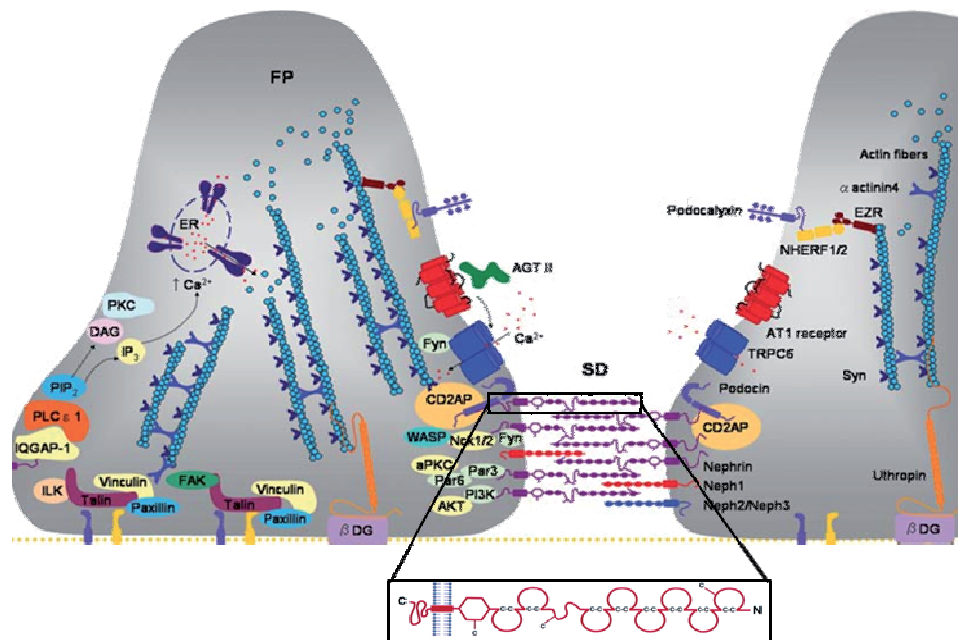

**Figure 20.** Structure and location of the nephrin protein in the slit diaphragm. FP, foot processes; SD, slit diaphragm (adapted from Machuca, Benoit, *et al.*, 2009).

Mutations in *NPHS1* are the major cause of CNS including CNF, the most severe form (Kestilä *et al.*, 1998). In Finland, two founder mutations account for more than 94% of all mutations. The Fin-major (p.L41fs\*91) account for 78% of patients and consists of a two-base pair deletion in exon 2 that results in a truncated protein of only 90 amino acids. The Fin-minor (p.R1109\*) accounts for 16% of patients and is a nonsense mutation in exon 26 that results in a premature stop codon leading to a protein of 1108 aminoacids. These two mutations both lead to the absence of nephrin in the podocyte slit diaphragm (Kestilä *et al.*, 1998). In non-Finnish populations, the Fin-major and Fin-minor mutations are rare and most patients have private mutations. The frequency of *NPHS1* mutations in non-Finnish patients is lower than in Finnish



patients, accounting for 39% to 58% of congenital NS cases (Hinkes *et al.*, 2007; Heeringa *et al.*, 2008; Schoeb *et al.*, 2010).

To date, more than 250 different mutations have been described, including nonsense, missense, frameshift insertions/deletions, and splicing mutations spanning over the whole gene. *In vitro* functional assays have shown that most *NPHS1* missense mutations lead to protein retention in the endoplasmic reticulum, possibly as a result of protein misfolding, resulting in defective intracellular nephrin trafficking out to the cell surface (Liu *et al.*, 2001). Interestingly, *in vitro* treatment with chemical chaperone rescued several of the missense mutants from the endoplasmic reticulum to the cell surface (Liu *et al.*, 2004).

The spectrum of renal disease related to *NPHS1* mutations has broadened with the identification of patients with *NPHS1* mutations and childhood and even adult onset SRNS (Philippe *et al.*, 2008; Santín, García-Maset, *et al.*, 2009). Philippe *et al.* found *NPHS1* mutations in 10 of 160 patients presenting with SRNS at a mean age of 3 years (from 6 months to 8 years), MCD or FSGS on renal biopsy, and ESRD at a mean age of 13.6 years (from 6 to 25 years). Santín *et al.* detected *NPHS1* mutations in a patient diagnosed at 27 years of age and with unimpaired renal function after two years of follow-up (Santín, García-Maset, *et al.*, 2009). All these patients carried a severe mutation and one mild mutation in compound heterozygous state. Mild mutations exhibited normal trafficking to the plasma membrane and maintained the abilities to form nephrin homodimers and to heterodimerize with NEPH1, suggesting that partial structural and signaling function was preserved (Philippe *et al.*, 2008). Patients carrying two mutations in the cytoplasmic domain were also associated with a mild phenotype (Machuca *et al.*, 2010). The homozygous p.R1160\* mutation has been reported to result in a mild CNF disease in about 50% of cases, mostly females. These patients have histological findings consistent with CNF and either mild proteinuria or complete remission up to 19 years of age (Koziell *et al.*, 2002). A summary of the mild mutations reported to date is shown in Figure 21.

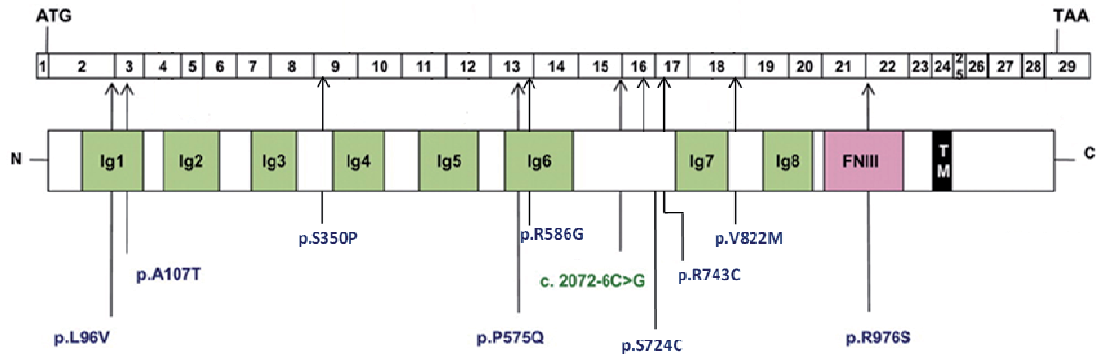

**Figure 21.** *NPHS1* mutations detected in the following studies: Liu *et al.*, 2001; Philippe *et al.*, 2008; Machuca *et al.*, 2010, and Schoeb *et al.*, 2010. Schematic representation of the localization of the mutations with respect to exons and protein functional domains. Ig, Ig-like domain; FNIII, fibronectin type III domain; TM, transmembrane domain (adapted from Philippe *et al.*, 2008).

### 5.1.2. *NPHS2* gene

The *NPHS2* gene spans approximately 25 kb on chromosome 1q25-q31 and contains 8 exons (Boute *et al.*, 2000). *NPHS2* encodes podocin, a 42-kDa integral membrane protein of 383 amino acids that belongs to the stomatin family. Podocin is almost exclusively expressed in the kidney at the podocyte slit diaphragm. It is predicted to be an integral membrane protein inserted in the membrane through a short hydrophobic region resulting in a hairpin-like topology with intracellular N- and C-terminal ends. It also contains a prohibitin homology domain that allows podocin binding to cholesterol in plasma membrane. This protein was shown to accumulate in oligomeric form in lipid-raft microdomains and to recruit nephrin in these specialized microdomains of the slit diaphragm plasma membrane (Huber, Simons, *et al.*, 2003). By also interacting with CD2AP and TRPC6, podocin represents an important link between the slit diaphragm and the podocyte cytoskeleton.

The classical phenotype associated with *NPHS2* mutations is early-childhood NS (nearly all before 6 years of age), resistant to corticosteroids and immunosuppressive agents, and rapid progression to ESRD (before the end of the first decade of life) with low recurrence after renal transplantation. Histological findings show FSGS in approximately 80% of cases although MCD are also found (Boute *et al.*, 2000; Weber *et al.*, 2004; Hinkes *et al.*, 2008). *NPHS2* mutations also are a frequent cause of CNS (15-39%), infantile SRNS (29-35.2%) and, to a lesser extent, adult onset SRNS (16%) (Bouchireb *et al.*, 2014; Sadowski *et al.*, 2014).

Mutations in *NPHS2* gene account for approximately 30-40% of familial cases (Karle *et al.*, 2002; Weber *et al.*, 2004; Berdeli *et al.*, 2007; Hinkes *et al.*, 2007; Hinkes *et al.*, 2008) and 10-

30% of sporadic (Caridi *et al.*, 2001; Caridi *et al.*, 2003; Berdeli *et al.*, 2007; Gbadegesin *et al.*, 2008; Megremis *et al.*, 2009; Jungraithmayr *et al.*, 2011).

To date, more than 110 *NPHS2* pathogenic mutations have been reported (LOVD mutation database). They are distributed throughout the entire gene and consist of all kinds of alterations, including missense, nonsense, frameshift, and splicing mutations. Missense mutations are the most frequent type of alteration accounting for 42% of the mutations (Bouchireb *et al.*, 2014).

*NPHS2* mutations are frequently found in patients from Central Europe, North America, Turkey, the Middle East, North Africa, and South America. However, they are not a major cause of SRNS in African American and Asian patients. Several founder mutations have been identified: p.R138Q in Europe, p.R138\* in the Israeli-Arab populations, p.V260E in the Comoros Islands, and p.A284V in South America. The R138Q mutation is the most prevalent mutation in European patients accounting for 32% and 44% of all affected *NPHS2* alleles in two large European series (Weber *et al.*, 2004; Hinkes *et al.*, 2008). However, in Spanish population it was only found in 2 of 14 alleles, accounting for 14% of all *NPHS2* affected alleles (Santín, Tazón-Vega, *et al.*, 2011). The arginine residue at position 138 is highly conserved among the stomatin-like protein family members and is crucial for podocin function (Boute *et al.*, 2000). The protein resulting from the substitution of glutamine for arginine is retained in the endoplasmic reticulum, impairing the intracellular trafficking of podocin to cell membrane and losing its ability to recruit nephrin in lipid rafts (Huber, Simons, *et al.*, 2003).

The nature of the mutations correlates with the age at onset of NS (Figure 22). Patients with frameshift or nonsense mutations in homozygous or compound heterozygous state have an earlier age at NS onset than those carrying two missense mutations (mean 1.75 years vs. 4.17 years) (Hinkes *et al.*, 2008). Missense mutations leading to retention of the mutant protein in the endoplasmic reticulum (such as the p.R138Q or the p.R168H) result in an earlier onset of disease than mutations that do not disrupt the mutant protein traffic to the plasma membrane ( $20.8 \pm 4$  vs.  $128.7 \pm 9$  months, respectively) (Roselli *et al.*, 2004). In congenital and infantile SRNS, the 94.1% of patients with *NPHS2* mutations were found to carry at least one truncating mutation or homozygous p.R138Q mutations, (Hinkes *et al.*, 2007). Missense mutations like the p.G92C, p.V180M and p.R238S are associated with a milder phenotype, a later age at onset of NS and ESRD. These mutations allow the targeting of the podocin mutant to the cell membrane, likely resulting in a partial function of the podocin that may explain the later age at onset of NS (around 10 years) (Weber *et al.*, 2004) and the less severe disease.

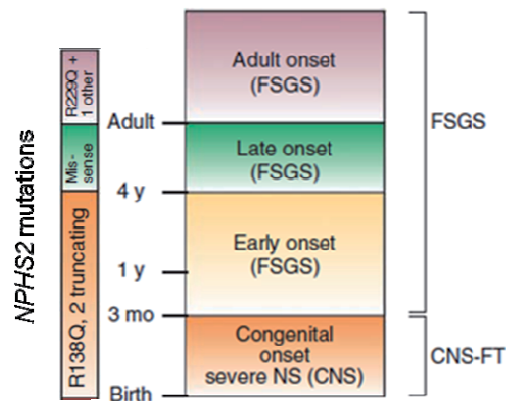

**Figure 22.** The nature of *NPHS2* mutation determines the age at onset of SRNS. CNS-FT, congenital nephrotic syndrome of Finnish type; FSGS, focal segmental glomerulosclerosis; mo, months; y, years (adapted from Hildebrandt & Heeringa 2009).

Patients carrying the p.R229Q and a pathogenic mutation have been associated with a significantly later onset of the disease. These patients represent almost all the adult onset cases with *NPHS2* mutations and they develop ESRD at a mean age of  $26.1 \pm 18.9$  years (Tsukaguchi *et al.*, 2002). The p.R229Q is the most frequently reported non-synonymous *NPHS2* variant in Caucasians (Franceschini *et al.*, 2006). A higher frequency of p.R229Q allele was found in SRNS, particularly in European or South American populations, than in controls (Machuca, Hummel, *et al.*, 2009). In Spanish population, p.R229Q was found in 5.3% of SRNS patients and in only 1.98% of controls (Santín, Tazón-Vega, *et al.*, 2011). In addition, *in vitro* studies demonstrated decreased binding of the p.R229Q mutant protein to nephrin, suggesting that this variant may be pathogenic (Tsukaguchi *et al.*, 2002). Recently, Tory *et al.* demonstrated that the pathogenicity of the p.R229Q variant depends on the trans-associated mutation. The p.R229Q variant lead to disease phenotype only when it is associated with certain specific C-terminal *NPHS2* mutations, which exert a dominant negative effect on p.R229Q podocin through altered dimerization and mislocalization. In contrast, patients carrying the p.R229Q in homozygous state are asymptomatic (Tory *et al.*, 2014). Interestingly in Spanish patients with late onset SRNS, the p.R229Q was frequently found in compound heterozygosity with the p.A284V pathogenic mutation, which is found in a conserved haplotype (Santín, Tazón-Vega, *et al.*, 2011).

### 5.1.3. *PLCE1* gene

The *PLCE1* gene spans 334.4 kb on chromosome 10q23 and contains 34 exons. This gene encodes the phospholipase C epsilon 1 (PLC $\epsilon$ 1) protein, a cytoplasmic enzyme that belongs to the phospholipase family of proteins and catalyzes the hydrolysis of polyphosphoinositides to

generate the second messengers: inositol 1,4,5-triphosphate (IP3) and diacylglycerol (DAG). These products initiate the cascade of intracellular pathways of cell growth and differentiation. This protein has two isoforms: PLC $\epsilon$ 1 isoform A of 2302 amino acids (258 kDa), and PLC $\epsilon$ 1 isoform B of 1994 amino acids (224 kDa). The PLC $\epsilon$ 1 protein contains the following putative protein domains: RasGEF\_CDC25 (guanine nucleotide exchange factor for Ras-like small GTPases domain), PH domain (Pleckstrin homology domain), EF hand, phospholipase catalytic domains (PLC\_X and PLC\_Y), C2 motif (protein kinase C conserved region 2, subgroup 2) and RA1 and RA2 domains (RasGTP binding domain from guanine nucleotide exchange factors) (Hinkes *et al.*, 2006). PLC $\epsilon$ 1 is expressed in the podocytes, neural tissue, and skeletal muscle of mouse embryos, as well as the skin, skeletal muscle and heart of adult mice (Tadano *et al.*, 2005; Wu *et al.*, 2003; Bai *et al.*, 2004). PLC $\epsilon$ 1 has an important role during glomerular development, and recruits nephrin to the plasma membrane via IQGAP1.

Mutations in *PLCE1* gene were identified in patients with early-onset NS and DMS or FSGS on renal histology (Hinkes *et al.*, 2006). Studies in large cohorts revealed that *PLCE1* mutations are the major cause of idiopathic DMS, accounting for approximately 28.6-33% of idiopathic DMS patients (Gbadegesin *et al.*, 2008). Mutations in this gene were also detected in about 8% of FSGS cases without *NPHS2* mutations. Patients with *PLCE1* mutations have an early-onset NS, mean age of  $22.8 \pm 5.0$  months, and lead to ESRD at a mean age of  $39.1 \pm 6.3$  months (Boyer *et al.*, 2010).

To date, more than 40 different mutations have been described, predominantly truncating mutations with no clustering around a specific gene region. In the initial cohort reported, all the individuals with homozygous truncating mutations presented DMS as histological lesion whereas two patients carrying homozygous non-truncating mutations presented FSGS (Hinkes *et al.*, 2006). However, in a more extensive study of 139 patients with early-onset SRNS, truncating and missense mutations led to similar renal presentation and evolution and were detected in patients with both, DMS and FSGS histological lesions. Recently, an earlier age of onset has been reported for patients carrying splice site mutations compared with C-terminal truncating mutations (after amino acid residue 1000) or missense mutations (Sadowski *et al.*, 2014). Renal prognosis is worst in patients with DMS compared to those with FSGS: mean age at onset of NS  $15.3 \pm 6.0$  months vs.  $30.5 \pm 7.7$  months, and mean age at ESRD  $20.9 \pm 5.8$  vs.  $57.2 \pm 7.3$  months, respectively (Boyer *et al.*, 2010).

In individuals with *PLCE1* mutations, the presence of DMS lesions with the appearance of immature glomeruli, together with the reduced nephrin and podocin expression, indicates that

PLCε1 is necessary for proper progression of glomerular development at the capillary loop stage. PLCε1 might interact with IQGAP1 in the vicinity of foot processes and might serve as an assembly scaffold for the organization of a multimolecular complex involved in morphogenetic processes of glomerular development at the capillary loop stage (Hinkes *et al.*, 2006).

Four families with transiently affected or asymptomatic family members carrying homozygous truncating mutations have been reported (Gilbert *et al.*, 2009; Boyer *et al.*, 2010). This finding raised the possibility that modifier genes or environmental factors could play a role in the renal phenotypic variability observed in individuals carrying *PLCE1* mutations, but additional variants in 19 candidate genes, including 16 phospholipases, were ruled out (Boyer *et al.*, 2010). The effect of modifiers genes could also explain the absence of an obvious renal phenotype in the *Plce1* knockout mouse model (Hinkes *et al.*, 2006).

#### 5.1.4. *CD2AP* gene

*CD2AP* spans approximately 170 kb on chromosome 6p12.3 and contains 18 exons. This gene encodes the CD2-Associated Protein (CD2AP), a protein of 639 aminoacids and 80 kDa. CD2AP protein was originally cloned as an interaction partner of CD2, a cell adhesion molecule found on the surface of T lymphocytes and natural killer cells that is implicated in T-cell adhesion to antigen-presenting cells. In the kidney CD2AP is expressed in proximal tubules, collecting ducts and podocytes, where it interacts with nephrin (Shih *et al.*, 1999), podocin (Schwarz *et al.*, 2001) and F-actin (Lehtonen *et al.*, 2002) suggesting its role in anchoring the slit diaphragm to the actin cytoskeleton.

The *Cd2ap* null mouse model was found to present not only an impaired T-cell function *in vitro* but also CNS leading to ESRD by 6-7 weeks of age (Shih *et al.*, 1999). In addition, mice with *Cd2ap* haploinsufficiency developed glomerular changes at 9 months of age and had increased susceptibility to glomerular injury by nephrotoxic antibodies or immune complexes (Kim *et al.*, 2003).

To date, only one homozygous *CD2AP* mutation in an infantile form of NS (Lowik *et al.*, 2007), two compound heterozygous *CD2AP* mutations in a congenital onset NS (Al-Hamed *et al.*, 2013), and five heterozygous mutations in pediatric and adult FSGS cases have been described (Kim *et al.*, 2003; Lowik *et al.*, 2008; Gigante *et al.*, 2009). The homozygous patient had failure to thrive secondary to nephrotic-range proteinuria and microscopic hematuria at the age of 10 months, FSGS on histology, and progressed to ESRD by the age of 3 years with no

recurrence after renal transplantation. Both parents were heterozygous and asymptomatic, discarding a haploinsufficient phenotype in this family (Lowik *et al.*, 2007). Studies in large international cohorts did not identify any mutation in *CD2AP*, suggesting that the contribution of this gene to SRNS is limited (Sadowski *et al.*, 2014).

#### 5.1.5. *PTPRO* gene

*PTPRO* gene encodes the protein tyrosine phosphatase receptor type O. This protein was identified in rabbit as a podocyte-specific transmembrane protein localized to the apical side of foot processes. This receptor might play a role in maintaining foot process structure and/or function by regulating tyrosine phosphorylation of podocyte proteins (Thomas *et al.*, 1994).

*PTPRO* mutations were identified in two Turkish consanguineous families (five individuals) by genome-wide analysis followed by homozygosity mapping. Patients with *PTPRO* mutations had an onset of SRNS between 5 and 14 years old with FSGS or MCD on histology and severe foot process effacement. One patient reached ESRD at the age of 18 years whereas the others had preserved renal function at 7, 11, 12 and 15 years old (Ozaltin *et al.*, 2011).

#### 5.1.6. *MYO1E* gene

*MYO1E* encodes myosin 1E (MYO1E), a member of the ubiquitously expressed class I myosins. In podocytes MYO1E is associated with the plasma membrane and is implicated in podocyte actin cytoskeleton organization and motility (Nabet *et al.*, 2009; Mele *et al.*, 2011).

Mutations in the *MYO1E* gene have been described in 5 families (7 individuals) with isolated SRNS, accounting for approximately 6% of patients. However, all the families reported to date had some degree of consanguinity. Thus, *MYO1E* mutations do not appear to be a common cause of SRNS in familial or sporadic cases but to account for a number of consanguineous families (Mele *et al.*, 2011; Al-Hamed *et al.*, 2013).

All the families presented with isolated SRNS and, in some cases, microhematuria was also described. They had an age at onset ranging from 4 months to 9 years and developed ESRD between 10 and 13 years of age, although four patients preserved normal renal function at 11, 13 and 14 (n=2) years old. Renal biopsy showed FSGS in all the cases except one with MCD (Mele *et al.*, 2011; Sanna-Cherchi *et al.*, 2011; Al-Hamed *et al.*, 2013). Affected members were resistant to treatment with corticosteroids but some of them responded to immunosuppressive treatment with cyclosporine (Mele *et al.*, 2011)(Mele C *et al.* 2011).



Myo1e-knockout mice have proteinuria, podocyte foot processes effacement, and chronic renal disease, mimicking the phenotype of individuals with *MYO1E* mutations (19 Mele). Functional studies in some of the mutations found revealed an abnormal subcellular localization of the protein or an impaired function due to the loss of important *MYO1E* domains (Mele).

### 5.1.7. *ARHGDI*A gene

The *ARHGDI*A gene encodes the Rho-GDP dissociation inhibitor-alpha (RhoGDI $\alpha$ ), which sequesters Rho-GTPases in an inactive state in the cytosol. A homozygous mutation in-frame deletion in *ARHGDI*A was found in two siblings of consanguineous Pakistani parents by whole-exome sequencing. Both siblings presented CNS with generalized edema, severe proteinuria and hypoalbuminemia. The renal biopsy performed in one of them revealed DMS. One sibling reached ESRD at 3 months whereas the other died. The mutation in this family led to a loss-of-function of RhoGDI $\alpha$  likely disturbing the balance of RHO-GTPases within podocytes, which would cause dearrangement of the actin cytoskeleton, podocyte injury, and NS (Gupta *et al.*, 2013). Gee *et al.* identified two more families with homozygous missense mutations in *ARHGDI*A gene by combining homozygosity mapping with whole-exome sequencing. These families presented with early onset SRNS (from 14 days to 2.4 years), DMS on renal biopsy (when performed), and rapidly progressed to ESRD (from 6 weeks to 3 years). Extrarenal features such as intellectual disability, sensorineural hearing loss, seizures or cortical blindness were reported in some patients. The missense mutations in these families abrogate interaction with RHO GTPases, increase active GTP-bound RAC1 and CDC42, and result in a migratory phenotypic change in podocytes (Gee *et al.*, 2013).

### 5.1.8. *ADCK4* gene

The *ADCK4* gene encodes the AarF Domain Containing Kinase-4, a protein of 544 amino acids and approximately 60 kDa. This protein localizes to the mitochondria and foot processes in podocytes and is suggested to be involved in coenzyme Q10 (CoQ<sub>10</sub>) biosynthesis (Ashraf *et al.*, 2013).

Recessive mutations in *ADCK4* have been identified in a total of 20 SRNS families (41 individuals), accounting for approximately 2% of SRNS screened. However, this prevalence might be overestimated by the fact that most families were consanguineous (Ashraf *et al.*, 2013; Korkmaz *et al.*, 2015).



The disease first manifested in adolescence, typically with mild to moderate proteinuria and no or mild edema. Hematuria was present in 25% of patients at diagnosis. All patients showed FSGS on biopsy. Advanced CKD was present in almost half of patients at time of diagnosis and progression to ESRD occurred exclusively in the second decade of life (Korkmaz *et al.*, 2015).

Patients with *ADCK4* mutations were found to have reduced cellular CoQ<sub>10</sub> content (Ashraf *et al.*, 2013; Desbats *et al.*, 2015). Hereditary defects of CoQ<sub>10</sub> biosynthesis cause SRNS as a part of multiorgan involvement but may also contribute to isolated SRNS. Patients with *ADCK4* mutations showed largely renal-limited phenotype, with only seven patients presenting signs and symptoms compatible with neurologic dysfunction (Ashraf *et al.*, 2013; Korkmaz *et al.*, 2015).

### 5.1.9. *TTC21B* gene

The *TTC21B* gene spans 96.37 Kb on chromosome 2q24 and contains 29 exons. This gene encodes the retrograde intraflagellar transport protein 139 (IFT139), consisting of 1216 amino acids and 151 kDa. It contains multiple tetratricopeptide repeat domains (TRP) that bind specific peptide ligands and are thought to mediate protein–protein interactions (Brinker *et al.*, 2002). IFT139 is a component of the intraflagellar transport-A complex that associates with the motor protein dynein2 to regulate retrograde trafficking in the primary cilium (Taschner *et al.*, 2012).

The primary cilium is a microtubule-based antenna-like organelle present on the surface of most cells. It is composed of the axoneme (a microtubule-based core structure) surrounded by a ciliary membrane that is continuous with the plasma membrane. The primary cilium plays an important role in sensing flow changes and mediating signaling pathways involved in the establishment of cell polarity during development (Ishikawa & Marshall 2011). The intraflagellar transport involves movement of large protein complexes, including IFT particles consisting of two distinct complexes: A and B. The anterograde movement (from cytoplasm to ciliary tip) is powered by kinesin-2 while the retrograde movement (from the ciliary tip to cytoplasm) is powered by dynein2 (Figure 24).

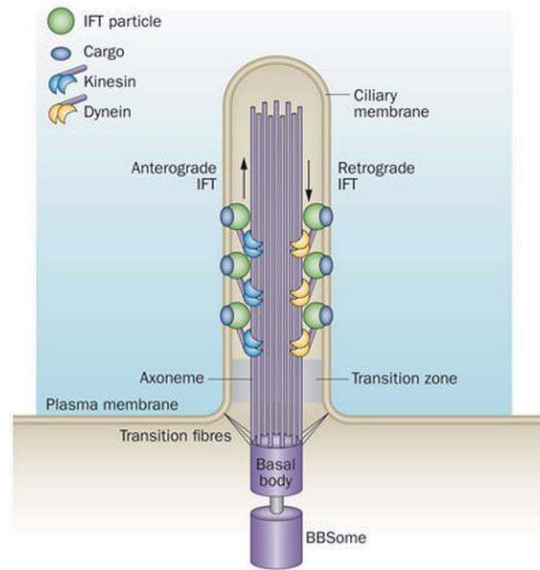

**Figure 23.** Structure and organization of the primary cilium (Valente *et al.*, 2014).

Mice carrying a homozygous null mutation in *Ttc21b* were embryonic lethal and their phenotype overlapped with the clinical features of severe ciliopathies in humans (Tran *et al.*, 2008). Mutations in *TTC21B* gene have been identified in nine individuals with different ciliopathies: Jeune Asphyxiating Thoracic Dystrophy (a chondrodysplasia that often leads to death in infancy); nephronophthisis with extra-renal manifestations; and isolated nephronophthisis (Davis *et al.*, 2011; Otto *et al.*, 2011; McInerney-Leo *et al.*, 2014). Of note, all patients with isolated nephronophthisis carried the homozygous p.P209L mutation. Unexpectedly, this same mutation has recently been identified in seven families with FSGS and tubulointerstitial lesions. All the reported patients with the p.P209L mutation share the same haplotype, indicating a founder effect for this mutation in patients of Portuguese or North African origin. Therefore, *TTC21B* is the first ciliary gene involved in a glomerular disorder (Huynh Cong *et al.*, 2014).

The clinical phenotype associated with *TTC21B* mutations is characterized by late-onset proteinuria (9-23 years), high blood pressure and ESRD at ages 15-32 years. Renal biopsies show FSGS together with characteristic alterations of nephronophthisis such as tubular basement membrane thickening, indicating the coexistence of primary glomerular and tubulointerstitial alterations (Huynh Cong *et al.*, 2014).

The IFT139 protein is expressed at the base of primary cilium in distal tubules but also in podocytes. Fetal podocytes have a primary cilium but it is lost in the maturation, then IFT139 expression is enhanced and relocalized along the microtubule network. Functional studies on the effect of the p.P209L mutation in glomerulus suggested that it causes cytoskeleton

alterations that may destabilize podocyte architecture leading to FSGS (Huynh Cong *et al.*, 2014).

#### 5.1.10. *CRB2* gene

The *CRB2* gene encodes the putative transmembrane Crumbs homolog 2 protein, a protein required for podocyte foot process arborization, slit diaphragm formation, and proper nephrin trafficking (Ebarasi *et al.*, 2015).

Homozygous or compound heterozygous mutations in *CRB2* gene have been identified by homozygosity mapping and whole exome sequencing in four families with childhood-onset (9 months-6 years) isolated SRNS and FSGS as histological lesions (Ebarasi *et al.*, 2015). All affected children carried a missense mutation in at least one allele, in accordance with the embryonic lethality of *Crb2* knockout mice (Xiao *et al.*, 2011). Of note, *CRB2* mutations were also detected in five fetuses and one infant with cerebral ventriculomegaly and echogenic kidneys with histopathological findings of congenital nephrosis (Slavotinek *et al.*, 2015).

#### 5.1.11. *NUP107* gene

The *NUP107* gene encodes the essential scaffold protein of the nuclear pore complex NUP107. This protein facilitates the efficient transfer of macromolecules between the nucleus and cytoplasm in a highly selective manner and plays pivotal roles in the nuclear framework and gene expression (Strambio-De-Castillia *et al.*, 2010).

Recessive mutations in *NUP107* gene have been identified by whole-exome sequencing in five SRNS families (nine individuals). In four of the five families, all the individuals showed early-onset SRNS manifesting at 2-3 years of age and reached ESRD before 10 years of age. In the remaining family, the two affected individuals had a disease onset after 10 years old, one of them reached ESRD at 12 years old whereas the other has preserved renal function at the current 34 years of age. In all the affected individuals renal biopsies revealed FSGS and they were resistant to corticosteroid therapy but partially responsive to immunosuppressive drugs. None of the five patients that underwent renal transplantation experienced recurrence of SRNS (Miyake *et al.*, 2015).

A total of four different mutations were found in the five families. Interestingly, the heterozygous p.D831A mutation was common in all the five families. This mutation is likely to be specific to East Asian because it has only been reported in Japanese population.

Furthermore, haplotype analysis confirmed that all the families shared the same haplotype confirming a common ancestor for this mutation. Mutations in *NUP107* are likely to cause immature and/or hypoplastic podocytes, or at least impaired podocytes that are progressively destroyed by increased filtration pressure after birth (Miyake *et al.*, 2015).

#### 5.1.12. *NUP93* gene

Mutations in *NUP93*, encoding nuclear pore protein 93 likely involved in nuclear pore complex assembly, have been recently identified in six families with SRNS (Braun *et al.*, 2016).

Phenotypically, affected members had SRNS that manifested between 1 and 6 years of age and caused ESRD between the ages of 1 and 11 years. Renal biopsy showed FSGS or DMS. In addition, there was a renal tubular phenotype involving tubular dilation with protein casts and interstitial cell infiltration. Electron microscopy showed partial podocyte foot process effacement. One patient showed partial response to corticosteroids, and two patients responded to immunosuppressive therapy with cyclosporine A (Braun *et al.*, 2016).

Five different mutations were detected in homozygous or compound heterozygous state including three missense mutations, one small deletion and one splicing mutation. The mutations p.G591V and p.Y629C apparently represent European and Turkish founder alleles, respectively. Functional studies revealed that *NUP93* mutations caused disrupted nuclear pore complex assembly and abrogated interaction with SMAD4, thus identifying aberrant SMAD signaling as a new disease mechanism of SRNS (Braun *et al.*, 2016).

## 5.2. Genes implicated in autosomal dominant isolated SRNS and FSGS

**Table2.** Genes causative of autosomal dominant isolated SRNS and FSGS.

Gene	Reference	MOI	Typical age at diagnosis of proteinuria/NS	Typical histology	Age at ESRD	Number of families (patients) published
<b>WT1</b>	Coppes <i>et al.</i> , 1992	AD	3-59 years	FSGS	10-69 years	7 (31)
<b>ACTN4</b>	Kaplan <i>et al.</i> , 2000	AD	3-54 years	FSGS	6-59 years	12 (>75)
<b>TRPC6</b>	Reiser <i>et al.</i> , 2005	AD	2-75 years	FSGS	0-20 years after onset	>28 (>62)
<b>INF2</b>	Brown <i>et al.</i> , 2010	AD	5-72 years	FSGS	13-70 years	>60 (>221)
<b>LMX1B</b>	Boyer <i>et al.</i> , 2013	AD	5-70 years	FSGS	28-70 years	8 (>28)
<b>ARHGAP24</b>	Akilesh <i>et al.</i> , 2011	AD	ND	FSGS	12-29 years	1 (3)
<b>ANLN</b>	Gbadegesin <i>et al.</i> , 2014	AD	9-69 years	FSGS	35-75 years	2 (12)
<b>PAX2</b>	Barua <i>et al.</i> , 2014	AD	7-68 years	FSGS	30-58 years	7 (24)

Abbreviations: AD, autosomal dominant; ESRD, end-stage renal disease; FSGS, focal segmental glomerulosclerosis; MOI, mode of inheritance; ND, no data; NS, nephrotic syndrome.

### 5.2.1. WT1 gene

The *WT1* gene spans 47.86 kb on chromosome 11p13 and contains 10 exons. This gene encodes Wilms Tumor protein 1 (WT1), a zinc finger transcription factor of 449 amino acids and 49 kDa that contains an N-terminal transactivation domain (exon 1) and four zinc-fingers at the C-terminal (exons 7-10). *WT1* encodes numerous isoforms, which are products of alternative translation start sites, alternative splicing, and RNA editing. Of particular interest are WT1(+KTS) and WT1(-KTS) variants, which differ by the presence of three amino acids (KTS) between the zinc fingers three and four. The presence of this insert influences the molecular biochemical properties of the resulting protein. While WT1(-KTS) bind DNA efficiently and acts as a transcriptional activator, WT1(+KTS) seem to have higher affinity to RNA and splicing factors (Hammes *et al.*, 2001).

WT1 protein plays a crucial role in kidney and genital tract development (Pritchard-Jones *et al.*, 1990; Rivera & Haber 2005). In the fetal kidney, WT1 is abundantly expressed in areas of

active glomerulogenesis whereas in the adult kidney, WT1 expression persists in podocytes and its integrity is required for proper GFB function (Morrison *et al.*, 2008).

Mutations in *WT1* gene are associated with a wide spectrum of AD syndromes in children including Wilms tumor (Gessler *et al.*, 1990), syndromic forms of glomerular disease and genitourinary abnormalities: Denys-Drash (Pelletier *et al.*, 1991), Fraiser Syndromes (Klamt *et al.*, 1998) and WAGR syndrome (Wilms tumor, Aniridia, Genitourinary abnormalities, and mental Retardation)(Miller *et al.*, 1964), and isolated SRNS (Jeanpierre *et al.*, 1998; Schumacher *et al.*, 1998; Ito *et al.*, 1999; Denamur *et al.*, 2000; Dharnidharka *et al.*, 2001; Ito *et al.*, 2001). Interestingly, *WT1*-associated disorders may include SRNS either as an initial symptom or as a later development in a patient diagnosed on the basis of extrarenal features.

The type and localization of the mutations has been clearly associated with the renal and extrarenal phenotypes. Germline alterations, usually truncating mutations, located throughout the entire coding sequence predispose to Wilms tumor. Heterozygous missense or truncating mutations in exons 8 and 9, mostly *de novo*, cause Denys-Drash syndrome or isolated SRNS (Mucha *et al.*, 2006). These mutations affect the DNA- and RNA-binding affinity of the second and third zinc finger domains. Heterozygous mutations in the donor splice site of intron 9 result in Fraiser Syndrome. These mutations lead to a reduction of the +KTS isoform causing the alteration of the normal ratio of +KTS/-KTS isoforms in the cell (Barboux *et al.*, 1997). Finally, large genomic rearrangement affecting chromosome 11p13 may disrupt *WT1* among several genes, resulting in WAGR syndrome.

The renal phenotype associated with *WT1* mutations is characterized by an early-onset SRNS and rapid progression to ESRD. In patients with mutations in exons 8 and 9 affecting the DNA binding capacity (classically associated with Denys-Drash Syndrome) NS presents in the first months of life, may be preceded by isolated proteinuria, and is always resistant to corticosteroid therapy. Progression to ESRD occurs most often before 4 years of age, and no recurrence is observed after renal transplantation (Habib *et al.*, 1985). Histological findings show DMS in most patients. In contrast, patients with KTS mutations, causing Fraiser syndrome, have a childhood-onset proteinuria usually between 2 and 6 years of age, almost invariably FSGS on biopsy, and slow progression leading to ESRD in adolescence or early adulthood.

The renal phenotype of patients carrying other exonic mutations is determined by the type of mutation. Most subjects with truncating mutations develop Wilms tumor early in life

whereas SRNS occurs later, typically in the second decade after nephrectomy. Missense mutations affecting amino acids in non-DNA binding positions are characterized by an intermediate renal phenotype manifesting within the first 5 years of life, usually presenting with DMS on biopsy, and progressing to ESRD at approximately 10 years old.

Female patients (46, XX) carrying either missense or splice-site *WT1* mutations commonly do not exhibit genital anomalies, have normal puberty, and therefore present with isolated sporadic SRNS (Ruf, Schultheiss, *et al.*, 2004; Mucha *et al.*, 2006). Missense mutations in exon 8 or 9 (p.R458Q, S461F, or R471K) affecting the second and third zinc fingers have been identified in families with isolated AD FSGS, including males without genital abnormalities or developmental tumors who transmitted the mutation (Coppes *et al.*, 1992; Benetti *et al.*, 2010; Guaragna *et al.*, 2013; Zhu *et al.*, 2013; Hall *et al.*, 2015).

Recently, a detailed study compared 61 patients with *WT1*-related SRNS with 700 SRNS patients negative for *WT1* mutations and revealed several genotype-phenotype correlations. *WT1* mutated patients presented more frequently with chronic kidney disease and hypertension at diagnosis and exhibit more rapid disease progression compared to *WT1* negative patients. FSGS is the most prevalent histopathological finding in *WT1* nephropathy but DMS is largely specific for *WT1* disease and is present in 34% of DMS cases (Lipska *et al.*, 2014). This finding goes against the results obtained by Gbadegesin *et al.* who identified mutations in *PLCE1* in 28.6% of families with DMS whereas mutations in *WT1* were only found in 8.5% of these families (Gbadegesin *et al.*, 2008). Extrarenal phenotypes are almost exclusive to *WT1* and mostly comprise: sex reversal and/or urogenital abnormalities (52%), Wilms tumor (38%), and gonadoblastoma (5%) (Lipska *et al.*, 2014).

### 5.2.2. *ACTN4* gene

A genome-wide scan performed in a 100-member kindred allowed Mathis *et al.* to map the first locus of AD FSGS on chromosome 19q13 (Mathis *et al.*, 1992; Mathis *et al.*, 1998). Linkage analysis including additional families helped to reduce the size of the region and led to the identification of three nonconservative missense mutations in the *ACTN4* gene (Kaplan *et al.*, 2000). *ACTN4* gene comprises 21 exons and encodes the  $\alpha$ -actinin-4 protein, a protein of 911 amino acids and about 105 kDa that belongs to the spectrin gene superfamily.  $\alpha$ -actinin-4 is an ubiquitously expressed actin-binding protein, that interconnects actin filaments in podocyte foot processes (Ichimura *et al.*, 2003). Its structure is a head-to-tail antiparallel homodimer with the following parts: two calponin homologous domains (CH1, CH2) with actin binding sites

in the N-terminal, followed by four spectrin repeats and two EF hand domains that can bind  $\text{Ca}^{2+}$  ions in the C-terminal (Baron *et al.*, 1987; Imamura *et al.*, 1988; Leinweber *et al.*, 1999).

Affected cases typically present with proteinuria starting in the adolescence or later, with FSGS lesions on kidney histology, and slowly progress to ESRD in the fifth decade of life. Also, heterozygous *ACTN4* mutations have seldom been reported in childhood-onset NS (Kaplan *et al.*, 2000; Weins 2005; Pollak *et al.*, 2007; Choi *et al.*, 2008). Disease incomplete penetrance and germline mosaicism has been described (Weins 2005; Choi *et al.*, 2008).

Mutations in the *ACTN4* gene were reported to account for approximately 2% of AD FSGS (Barua *et al.*, 2013). However, recent studies in large cohorts did not identify any patient carrying *ACTN4* mutations, suggesting an even lower contribution of mutations in this gene to AD FSGS (Sadowski *et al.*, 2014).

To date, 16 mutations have been reported. Most of them are missense mutations involving residues within or next to the actin binding site of  $\alpha$ -actinin-4 (Kaplan *et al.*, 2000; Ichimura *et al.*, 2003; Weins 2005; Barua *et al.*, 2013; Giglio *et al.*, 2015). Some of these mutations have been shown to increase the affinity of  $\alpha$ -actinin-4 to F-actin and/or induce  $\alpha$ -actinin-4 mislocalization and the formation of  $\alpha$ -actinin-4 and F-actin aggregates around the nucleus with subsequent impairment of podocyte spreading and motility (Kaplan *et al.*, 2000; Weins 2005; Yao *et al.*, 2004; Michaud 2003; Michaud *et al.*, 2006). Knock-in and knockout mouse models and *in vitro* data suggest both gain-of-function and loss-of-function mechanisms (Yao *et al.*, 2004).

### 5.2.3. *TRPC6* gene

*TRPC6* spans approximately 421 kb on chromosome 11q22 and contains 13 exons. This gene encodes the short transient receptor potential canonical 6 (TRPC6), a protein of 931 amino acids and around 106 kDa. TRPC channels are tetrameric proteins composed of six transmembrane-spanning domains and N- and C-terminal facing the cytosol (Venkatachalam & Montell 2007). The fifth and sixth transmembrane domains line the pore of the ion channel (Hofmann *et al.*, 2002) (Figure 26). TRPC6 is a receptor-operated non-selective cation channel, which allows intracellular  $\text{Ca}^{2+}$  to flow into the cell in response to activation by DAG secondary to phospholipase C mediated signal coming from stimulation of specific cell surface receptors (Hofmann *et al.*, 1999; Montell 2005). In the kidney, TRPC6 is expressed in renal tubules and in glomeruli, with predominance in podocytes. TRPC6 co-localizes with podocin and nephrin and



immunoprecipitation studies showed physical interaction between TRPC6 and these proteins, indicating that the channel is integrated into the signaling complex at the slit diaphragm. Therefore, TRPC6 is critical in adjusting the cationic ion flux close to the slit diaphragm (Reiser *et al.*, 2005). In addition, Moller *et al.* demonstrated that TRPC6 is functionally connected to the actin cytoskeleton in the podocyte (Möller *et al.*, 2007).

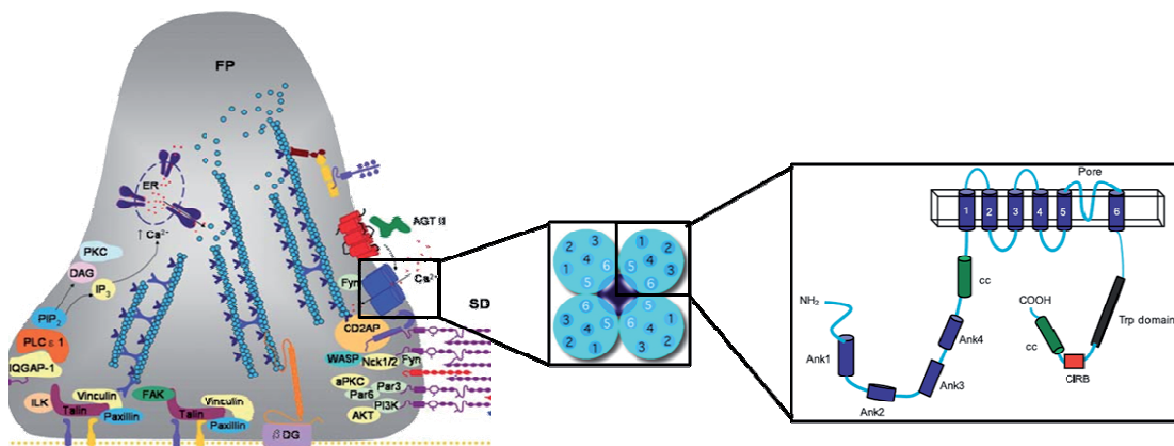

**Figure 24.** Structure and location of the TRPC6 protein in the slit diaphragm. FP, foot processes; SD, slit diaphragm. Ank, ankyrin repeat; cc, coiled-coil; CIRB, calmodulin and IP3 receptor-binding (adapted from Machuca *et al.*, 2009; Dryer & Reiser 2010).

Linkage analysis of a 399-member family with FSGS identified a locus on chromosome 11q21-q22 that linked to the disease (Winn *et al.*, 1999). This region contained several known genes as well as multiple novel and predicted genes, which were systematically screened for mutations by direct sequencing. After examination of 42 genes, *TRPC6* emerged as a candidate on the basis of reports of detection of TRPC6 mRNA in the kidney (Riccio *et al.*, 2002; Garcia & Schilling 1997). Sequencing of the 13 exons of this gene identified a missense mutation p.P112Q in exon 2 that segregated with the disease in all available family members consistent with an autosomal dominant pattern (Winn 2005). Additional work was reported by Reiser *et al.* who identified five families with mutations in *TRPC6* that segregated with FSGS, although incomplete penetrance was observed (Reiser *et al.*, 2005).

Based on these two studies the phenotype associated with *TRPC6* mutations is late-onset AD FSGS and variable rate of progression to ESRD (Winn 2005; Reiser *et al.*, 2005). However, a significant number of sporadic and childhood-onset FSGS cases have been identified. Childhood-onset SRNS has been reported in nine patients carrying *TRPC6* mutations (Santín, Ars, *et al.*, 2009; Heeringa *et al.*, 2009; Buscher *et al.*, 2012; Gigante *et al.*, 2011; Mir *et al.*, 2012). Renal biopsy typically showed FSGS but collapsing glomerulopathy (Gigante *et al.*, 2011; Liakopoulos *et al.*, 2011) and MCD have been reported (Gigante *et al.*, 2011; Mottl *et al.*,

2013). This high phenotypic variability can also occur within members of the same family even with mutation carriers showing either no signs or mild signs of the disease, indicating that the disease is not fully penetrant (Reiser *et al.*, 2005; Santín, Ars, *et al.*, 2009). Studies in large cohorts revealed that *TRPC6* mutations account for approximately 8% of AD FSGS patients (Sadowski *et al.*, 2014).

To date, 19 different mutations have been reported in 22 familial/sporadic patients from different ethnic background. Three mutations are located in the ANK1, two in the ANK2, one in ANK3, one in ANK4, and five additional N-terminal mutations are located outside of the predicted ANK domains (Reiser *et al.*, 2005; Winn 2005; Santín, Ars, *et al.*, 2009; Gigante *et al.*, 2011; Heeringa *et al.*, 2009; Buscher *et al.*, 2012; Hofstra *et al.*, 2013; Mir *et al.*, 2012). Seven other *TRPC6* mutations were located to the C-terminal cytoplasmic tail (Reiser *et al.*, 2005; Santín, Ars, *et al.*, 2009; Gigante *et al.*, 2011; Zhu *et al.*, 2009; Mottl *et al.*, 2013), four of them mapping to a predicted coiled-coil domain at the C-terminal (Gudermann *et al.*, 2004). No mutations have been identified in the transmembrane, extracellular or pore-forming regions of the channel.

Several of these mutations are gain-of-function mutations leading to increased channel activity by increasing calcium current amplitudes or by delaying channel inactivation. The p.N143S, p.S270T and p.K874\* mutations did not modify the calcium influx during the functional assays, suggesting that an abnormality other than increased current amplitude is the cause of disease in individuals with these mutations. The several possibilities include altered channel regulation (despite normal amplitude), altered interaction with other slit diaphragm proteins and altered protein turnover (Reiser *et al.*, 2005).

#### 5.2.4. *INF2* gene

The *INF2* gene spans approximately 33 kb on chromosome 14q32 and contains 23 exons. This gene encodes the inverted formin 2 (*INF2*), a protein of 1249 amino acids and around 136 kDa that belongs to formin family. Formins are widely expressed proteins governing several dynamic events that require remodeling of the actin cytoskeleton such as cell polarity, cell and tissue morphogenesis, and cytokinesis (Boyer, Benoit, *et al.*, 2011). The *INF2* protein has the unique ability to accelerate both polymerization and depolymerization of actin (Chhabra *et al.*, 2009). This protein contains the following domains, from N-terminal to C-terminal: the diaphanous inhibitory domain (DID), the formin homology domains FH1 and FH2, and the diaphanous regulatory domain (DAD). The FH2 domain directly mediates actin assembly, and

the FH1 domains accelerate filament elongation. Interaction between DID and DAD blocks the ability of FH2 to interact with actin, inhibiting actin depolymerization but not actin polymerization. This step is inhibited by the binding of Rho GTPases to DID impeding its interaction with DAD (Boyer, Benoit, *et al.*, 2011; Gbadegesin *et al.*, 2012).

Mutations in *INF2* gene were identified as a cause of AD FSGS by Brown *et al.* (Brown *et al.*, 2010). Studies in large cohorts described that *INF2* mutations account for approximately 9%-17% of familial AD FSGS and <1% of sporadic cases (Boyer, Benoit, *et al.*, 2011; Gbadegesin *et al.*, 2012; Barua *et al.*, 2013). Mutations in this gene are also the main cause of Charcot-Marie-Tooth disease with FSGS (Boyer, Nevo, *et al.*, 2011).

The clinical phenotype of individuals with *INF2* mutations is characterized by moderate proteinuria, without overt NS, manifesting at early adolescence or adulthood that is progressive and often led to ESRD. However, nephrotic range proteinuria and full-blown NS at onset have been described. Microscopic hematuria and hypertension at onset have been noted in some individuals. Most individuals have an onset of the disease in the second to fourth decade of life with onset of renal failure in the third decade (Barua *et al.*, 2013) but significant variability has been reported. Considering all the patients published to date, age at proteinuria onset ranges from 5 years to 72 years and age at ESRD onset from 13 to 70 (Brown *et al.*, 2010; Boyer, Benoit, *et al.*, 2011). Intra-familial variability in the clinical expression of the disease is also wide with clinically unaffected members carrying the same mutation that their affected son or daughter, consistent with incomplete penetrance that is often seen in AD diseases (Lee *et al.*, 2011; Boyer, Benoit, *et al.*, 2011; Gbadegesin *et al.*, 2012).

All the mutations described to date (more than 40) are highly conserved residues within the DID domain. Most of them cluster in exon 4 and 2, accounting for approximately 80% and 10% of mutations, respectively. Mutations in exons 3 and 6 have been reported in two and one families, respectively (Barua *et al.*, 2013; Sanchez-Ares *et al.*, 2013).

Many of the mutations reported are recurrent with certain codons appearing to be hotspots, such as Arg218 or Arg214. Mutations in Arg218 have been described in eight unrelated families, six of them carry the p.R218Q mutation (Brown *et al.*, 2010; Boyer, Benoit, *et al.*, 2011; Gbadegesin *et al.*, 2012; Barua *et al.*, 2013) whereas the remaining 2 families carry the p.R218W mutation (Barua *et al.*, 2013). Mutations in Arg214 have been described in eight families four of them carry the p.R214H (Brown *et al.*, 2010; Gbadegesin *et al.*, 2012) mutation while the remaining four families carry the p.R214C mutation (Boyer, Benoit, *et al.*, 2011;

Gbadegesin *et al.*, 2012; Barua *et al.*, 2013). A possible founder effect of these mutations was studied by haplotype analysis but no common ancestral disease-associated haplotype was found (Boyer, Benoit, *et al.*, 2011).

*INF2* mutations have been suggested to cause defects in actin-mediated podocyte structural maintenance and repair (Brown *et al.*, 2010). Most of the mutations reported have been shown to cause mislocalization of INF2 in podocyte culture and some of them also inhibit the interaction between INF2-DID and mDias-DAD (mouse Diaphanous-related formins), suggesting that changes are functionally important for regulation of actin cytoskeleton (Gbadegesin *et al.*, 2012).

### 5.2.5. *LMX1B* gene

The *LMX1B* gene encodes the LIM homeodomain-containing transcription factor 1B (LMX1B) that is essential during development. Mutations in *LMX1B* cause Nail-Patella syndrome associating dysplasia of the patellae, nails and elbows, iliac horns, glaucoma and, in some cases, FSGS with specific lesions characterized by the presence of type III collagen fibrils in the GBM by electron microscopy (Dreyer *et al.*, 1998). However, *LMX1B* mutations have been identified in four families (14 individuals) with AD FSGS but no glomerular membrane anomaly suggestive of nail-patella-like renal disease by electron microscopy and no extrarenal features (Boyer *et al.*, 2013; Edwards *et al.*, 2015). These patients presented significant albuminuria between 5 and 70 years of age, and some of them reached ESRD between 26 and 70 years of age. The three different mutations detected (p.R246Q, p.R246P and p.R249Q) are located in the LMX1B homeodomain. The affected residues are likely to play an important role in strengthening the interaction between the homeobox domain of LMX1B and DNA, by holding interactions with the DNA (Boyer *et al.*, 2013).

### 5.2.6. *ANLN* gene

The *ANLN* gene encodes for anillin, an F-actin binding protein that is enriched in the cytoskeleton. Heterozygous missense mutations in *ANLN* have recently been described in two families with AD FSGS by genome-wide linkage study and whole-exome sequencing. The age at proteinuria onset varied from 9 to 69 years and ESRD occurred between 35 and 75 years (Gbadegesin *et al.*, 2014).

### 5.2.7. *PAX2* gene

*PAX2* is a transcription factor expressed from the fourth week of gestation in the kidney and play a critical role in kidney development (Nakanishi & Yoshikawa 2003). Mutations in this gene have typically been associated with congenital abnormalities of the kidney and urinary tract (CAKUT) as part of a syndrome known as renal coloboma or papillorenal syndrome (Sanyanusin *et al.*, 1995). Barua *et al.* identified a *PAX2* mutation in a family with AD FSGS by exome sequencing. Sequencing of the *PAX2* gene in FSGS families revealed a *PAX2* mutation in 7 of the 175 families analyzed (24 patients), suggesting that mutations in *PAX2* might account for approximately 4% of families with FSGS (Barua *et al.*, 2014).

The affected patients had various degrees of proteinuria diagnosed between 7 and 68 years old (mostly second to fourth decades) and FSGS on biopsy. ESRD occurred in nine patients between 30 and 58 years old. Kidney ultrasound in patients with *PAX2*-related FSGS either was normal or could reveal echoic or small kidneys, dilated renal pelvis, or calyceal diverticulum. Most patients did not exhibit any extrarenal symptom, but renal coloboma was diagnosed retrospectively in one family (Barua *et al.*, 2014).

Interestingly, a patient with a *PAX2* mutation together with the homozygous p.R229Q in the *NPHS2* gene has been reported. This patient presented with sub-nephrotic proteinuria at 7 months. At 20 years old he presented nephrotic-range proteinuria, FSGS on renal biopsy and his renal function progressively deteriorated reaching ESRD at 33 years of age. No recurrence of the disease was observed after one year of renal transplantation. Additionally, he presented ocular abnormalities in accordance with the ocular abnormalities seen in renal coloboma (Kerti *et al.* 2013).

### 5.3. Genes implicated in syndromic forms of SRNS and FSGS

Gene	Reference	MOI	Typical age at diagnosis of proteinuria/NS	Typical histology	Age at ESRD	Syndrome: recurrent extrarenal involvement	N° families (patients) published
<b>SRNS with genitourinary features</b>							
<b>WT1</b>	Pelletier <i>et al.</i> , 1991	AD	0 – 10 years	DMS	0 – 15 years	Dennys-Drash sd: Wilms tumor in both genders, genital anomalies in 46,XY patients	>170
<b>WT1</b>	Klamt <i>et al.</i> , 1998	AD	7 months to 34 years	FSGS	5 to ≥ 34 years	Fraiser sd: Pseudohermaphroditism, gonadoblastoma in 46,XY patients	>60
<b>SRNS with osseous dysplasia</b>							
<b>LMX1B</b>	Dreyer <i>et al.</i> , 1998	AD	9 – 76 years	FSGS, NPS-nephropathy	22-52	Nail-Patella sd: hypoplastic nails/patellae, iliac horns	>35 (>54)
<b>SMARCAL1</b>	Boerkoel <i>et al.</i> , 2002	AR	2 – 12 years	FSGS	3.8 – 22 years	Schimke Immuno-osseous dysplasia: spondyloepiphyseal dysplasia, T-cell deficiency, cerebral ischemia, broad nasal tip, hyperpigmented macules	>90
<b>Mitochondriopathies with SRNS</b>							
<b>MTTL1</b>	Goto <i>et al.</i> , 1990	Maternal	5 – 47 years	FSGS	13 – 51 years	MELAS: myopathy, encephalopathy, lactic acidosis, and stroke-like episode, diabetes, and deafness	>30 (>45)
<b>COQ2</b>	Quinzii <i>et al.</i> , 2006	AR	0 – 30 months	FSGS	0 to ≥ 5 years	COQ10 deficiency: encephalomyopathy, hypotonia, seizures, lactate acidosis	10 (13)
<b>PDSS2</b>	Lopez <i>et al.</i> , 2006	AR	0-23 months	ND	No data	COQ10 deficiency: encephalomyopathy, hypotonia, seizures, lactate acidosis	3 (3)
<b>COQ6</b>	Heeringa <i>et al.</i> , 2011	AR	2 months to 6.4 years	FSGS	5 months to 9.3 years	COQ10 deficiency: sensorineural deafness, seizure	8 (16)
<b>SCARB2</b>	Balreira <i>et al.</i> , 2008	AR	9 to > 59 years	FSGS	9 to > 59 years	Progressive myoclonic epilepsy, cerebral and cerebellar atrophy, peripheral neuropathy, hearing impairment	18 (24)
<b>SRNS with cutaneous features</b>							

Gene	Reference	MOI	Typical age at diagnosis of proteinuria/NS	Typical histology	Age at ESRD	Syndrome: recurrent extrarenal involvement	N° families (patients) published
<b>ITGB4</b>	Kambham <i>et al.</i> , 2000	AR	2 months to 10 years	FSGS	NA	Junctional epidermolysis bullosa, nail dystrophy, recurrent hemorrhagic cystitis, desquamation of laryngeal mucosa	2 (2)
<b>LAMB3</b>	Hata <i>et al.</i> , 2005	AR	≤4 months	DMS	NA (5 months*)	Epidermolysis bullosa, nail dystrophy	1 (1)
<b>ITGA3</b>	Nicolaou <i>et al.</i> , 2012	AR	0-4 years	FSGS	2 weeks to ≥ 4 years	Interstitial lung disease, epidermolysis bullosa	6 (6)
<b>CD151</b>	Karamatic <i>et al.</i> , 2004	AR	ND	ND	Thickening of GBM	Pretibial epidermolysis bullosa, sensorineural deafness, lacrimal duct stenosis, nail dystrophy	2 (2)
<b>SRNS with intellectual disability</b>							
<b>ARHGDI1</b>	Gupta <i>et al.</i> , 2013	AR	0 – 2.4 years	DMS	6 weeks to 3 years	Intellectual disability	3 (6)
<b>KANK4</b>	Gee <i>et al.</i> , 2015	AR	2 months	FSGS	ND	Intellectual disability, short stature, facial dysmorphism, atrial septal defect, dilative cardiomyopathy, leukocytosis	2 (2)
<b>XPO5</b>	Braun <i>et al.</i> , 2016	AR	2 years	MCD	ND	Speech development delay	1 (1)
<b>SRNS with other features</b>							
<b>LAMB2</b>	Hasselbacher K <i>et al.</i> , 2006	AR	0 – 6 years	DMS	0-21 years	Pierson sd: microcoria, abnormal lens, VI, hypotonia, motor delay	>60 (>70)
<b>WDR73</b>	Colin <i>et al.</i> , 2014	AR	5 to > 13 years	FSGS	≥ 5 years	Galloway-Mowat sd: secondary microcephaly, intellectual deficiency, cortical and cerebellar atrophy, facial dysmorphism, optic atrophy	2 (3)
<b>INF2</b>	Boyer <i>et al.</i> , 2011	AD	10 – 46 years	FSGS	12 – 47 years	Charcot–Marie–Tooth neuropathy, deafness	27 (44)
<b>NUP205</b>	Braun <i>et al.</i> , 2016	AR	2-3 years	FSGS	7 years	Bicuspid aortic valve, aortic insufficiency, aortic root enlargement	1 (2)

Abbreviations: AD, autosomal dominant; AR, autosomal recessive, diffuse mesangial sclerosis; ESRD, end-stage renal disease; FSGS, focal segmental glomerulosclerosis; MCD, minimal change disease; MOI, mode of inheritance; ND, no data; NPS, Nail-patella syndrome; NS, nephrotic syndrome; sd, syndrome.

## 6. CLINICAL UTILITY OF GENETIC TESTING

---

The identification of the genetic cause of SRNS has several clinical implications:

- Provides an unequivocal molecular diagnosis for the patients and their family members and may diagnose previously unrecognized affected family members.
- Predicts resistance to corticosteroid and/or immunosuppressive therapy. Therefore, the unnecessary extension of corticosteroid treatment as well as the potential risk and side effects associated with these treatments can be avoided (Weber *et al.*, 2004; Ruf, Lichtenberger, *et al.*, 2004; Buscher *et al.*, 2010; Giglio *et al.*, 2015).
- A low risk of relapse after renal transplantation, hence, living donor renal transplantation is encouraged.
- Genetic counseling (prenatal or preimplantation genetic diagnosis) for family planning can be offered to couples with known risk for severe NS, in whom the causative mutations have been identified in a first affected child.
- Prognosis information depending on which gene is mutated and the type of mutations considering the genotype-phenotype correlations explained in the previous section.

Although these clinical implications are generally applicable to all patients with a genetic cause of SRNS identified, specific particularities and/or exceptions have been described depending on the mutated gene.

Most patients with *NPHS1* mutations are resistant to corticosteroids and immunosuppressive treatment. However, five patients (three families) with compound heterozygous or homozygous missense mutations and partial remission have been reported (Kitamura *et al.*, 2007; Heeringa *et al.*, 2008; Schoeb *et al.*, 2010). Two siblings with frequent relapsing NS that carried compound heterozygous p.C265R and p.V822M mutations in *NPHS1* gene achieved remission of proteinuria without immunosuppressive treatment. Functional studies showed that the p.C265R mutation was trapped in the endoplasmic reticulum whereas the p.V822M mutation partially reached the plasma membrane, likely explaining their milder disease (Kitamura *et al.*, 2007). In the remaining three patients (two families) partial remission due to steroid treatment was achieved (Heeringa *et al.*, 2008; Schoeb *et al.*, 2010).

Post-transplantation recurrence in *NPHS1* mutated patients is very low. However, in a study of patients with Fin-Major or Fin-minor mutations (that lead to the absence of nephrin) recurrence occurred in 25% of patients at a mean time of 12 months post-transplantation. All



these patients were homozygous for the Fin-major mutation, which leads to an early stop-codon and total absence of nephrin in the native kidney. In almost half of them antibodies against nephrin were detected (Patrakka *et al.*, 2002). Similarly, Kuusniemi *et al.* reported post-transplant recurrence rate in 30% of patients homozygous for the Fin-major mutation and 70% of them showed anti-nephrin antibodies (Kuusniemi 2007). Two patients with mutations different from the Fin-major and post-transplant recurrence have also been reported (Srivastava *et al.*, 2006; Chaudhuri *et al.*, 2012). In one of them anti-nephrin antibodies were detected (Chaudhuri *et al.*, 2012). Thus, recurrence in these patients was considered an immune process against the nephrin present in the graft and treatment with immunosuppressive agents led to remission in some cases (Flynn *et al.*, 1992).

During pregnancy, elevated AFP in the maternal serum and amniotic fluid is indicative of CNS. However, elevated AFP is not a specific marker of CNS as it has also been observed in *NPHS1* heterozygous fetal carriers and in a fetus with Denny-Drash syndrome (Devriendt *et al.*, 1996; Patrakka *et al.*, 2002). Therefore, prenatal genetic diagnosis is required to confirm CNS before considering medical termination of pregnancy.

*NPHS2* mutated patients do not generally respond to corticosteroid or immunosuppressive therapy, but a partial reduction of proteinuria has been reported with cyclosporine A in eight patients (Ruf, Lichtenberger, *et al.*, 2004; Malina *et al.*, 2009; Machuca, Hummel, *et al.*, 2009). However, complete remission in SRNS caused by *NPHS2* mutations have not been reported (Ruf, Lichtenberger, *et al.*, 2004; Buscher *et al.*, 2010). Post-transplant disease recurrence is significantly low in patients with *NPHS2* mutations than in patients without mutations, 4.5% vs. 28.5%, respectively according to a recent study in a large international cohort (Trautmann *et al.*, 2015). However, post-transplant disease recurrence has been described in 12 patients (Carraro *et al.*, 2002; Bertelli *et al.*, 2003; Billing *et al.*, 2004; Weber *et al.*, 2004; Hocker *et al.*, 2006; Becker-Cohen *et al.*, 2007; Trautmann *et al.*, 2015). The most common mutations in these patients was the p.R138\* and the p.R138Q. There is no evidence of podocin antibodies in these patients, thus the pathomechanism of disease recurrence in *NPHS2* mutated patients remains unknown and is probably multifactorial (Holmberg & Jalanko 2014).

The identification of *PLCE1* represents the first molecular cause of NS that might respond to therapy in some individuals. Two children responded to treatment with corticosteroids or cyclosporine A achieving a complete remission and remained free of proteinuria after several years of follow-up (Hinkes *et al.*, 2006). Based on these findings, it has been speculated that the arrest of glomerular development through *PLCE1* mutations may be reversible by

treatment with corticoids or cyclosporine A *via* induction of a redundant mechanism such as the activity of another phospholipase C (Hinkes *et al.*, 2006). Thus, corticosteroid and immunosuppressive treatment is advised in patients with *PLCE1* mutations. No post-transplant recurrence has been described to date.

Patients with *WT1* mutations were described to be unresponsive to therapy. However, a partial response to immunosuppressive agents has been described in some patients (Gellermann *et al.*, 2010; Buscher *et al.*, 2010). Gellermann *et al.* reported a favorable response to a therapy consisting of cyclosporine A in combination with corticosteroids in 3 patients with FSGS associated with *WT1* mutations (Gellermann *et al.*, 2010). B scher *et al.* reported 2 patients who achieved a partial response to cyclosporine A: one phenotypically female Fraiser patient (karyotype XY) affected by a *WT1* splice-site mutations and one patients (karyotype XX) with isolated FSGS affected by a *WT1* missense mutation (Buscher *et al.*, 2010).

In patients with *WT1* mutations, the karyotype of females should be investigated in order to exclude the 46 XY karyotype with pseudohermaphroditism. These patients should also be screened for the development of for the development of Wilms Tumor or gonadoblastoma (Rood *et al.*, 2012). Genetic counseling is essential in both female and males, as they have a 50% risk to transmit the mutation. Although most *WT1* mutations are *de novo*, parents of a child with a *WT1* mutation should be advised of a low probability of recurrence due to the possibility of germinal mosaicism, which has an unknown likelihood.

Potential therapy is available for some rare causes of SRNS. For instance, identification of mutations in a gene encoding enzymes of the CoQ<sub>10</sub> biosynthesis (*COQ2*, *COQ6*, *ADCK4* or *PDSS2*) may warrant experimental treatment with CoQ<sub>10</sub> (Heeringa *et al.*, 2011; Montini *et al.*, 2008) as partial response to treatment with coenzyme Q<sub>10</sub> has been described in individuals with SRNS and mutations in *COQ2* (Montini *et al.*, 2008), *COQ6* (Heeringa *et al.*, 2011) and *ADCK4* (Ashraf *et al.*, 2013). Similarly, individuals with *TRPC6* mutations may potentially be amenable to treatment with calcineurin inhibitors (Schlondorff *et al.*, 2009), patients carrying *CUBN* mutations may be amenable to treatment with vitamin B12, and individuals with *ARHGDI1* mutations may theoretically be responsive to the eplerenone treatment (Gee *et al.*, 2013).

Genetic testing in SRNS should be strongly advised in those patients with a likely a genetic cause of the disease: 1) in CNS patients, 2) in childhood-onset SRNS patients, both familial and sporadic, 3) in adult onset patients with a family history of the disease, and 4) in patients from

consanguineous marriages. This advice is based on the relatively high prevalence of genetic causes in these groups.

**AIMS**

---



The global aim of the present thesis was to increase our knowledge on the contribution of genetics to the pathogenesis and clinical outcome of idiopathic membranous nephropathy (IMN) and SRNS/FSGS.

The first part of this thesis was focused on the association of genetic polymorphisms: SNPs and Copy number variants (CNVs), with the risk to develop IMN and its clinical course. Specific aims of this part were:

- To validate the association of *HLA-DQA1* and *PLA2R1* genes with the risk to develop IMN in Spanish population.
- To test the putative association of CNVs within *FCGR3A* and *FCGR3B* genes with susceptibility to IMN in Spanish population.
- To assess the contribution of these genetic factors to predict the clinical outcome and renal function decline.

The second part of this thesis aimed to analyze the genetic causes of SRNS/FSGS as well as to identify genetic modifiers of disease severity. Particular aims of this part were:

- To improve the genetic testing of SRNS/FSGS.
- To assess the putative influence of mutations in multiple glomerular genes on SRNS/FSGS phenotype variability.
- To study the causative and modifying role of *TTC21B* gene

The final aim of the present thesis was to develop an efficient and comprehensive genetic diagnosis including all known genes causative of glomerular and cystic inherited kidney diseases.

