

Date of publication xxxx 00, 0000, date of current version xxxx 00, 0000.

Digital Object Identifier 10.1109/ACCESS.2017.Doi Number

Monitoring Method on Loosened State and Deformational Fault of Transformer Winding Based on Vibration and Reactance Information

CHEN CAO ¹, BOWEN XU ², XUEBIN LI ³

¹ School of Electrical Engineering, School of Information Science and Engineering, Shenyang University of Technology, Shenyang110870, People's Republic of China

² Department of Civil Engineering, Xi'an Jiaotong-Liverpool University, Suzhou215123, People's Republic of China

³ State Grid Liaoning Electric Power Supply Co.,LTD. ,Shenyang 110004,People's Republic of China

Corresponding author: BOWEN XU (e-mail: Bowen.Xu@xjtlu.edu.cn).

This work was supported in part by National Natural Science Foundation of China (51177104), Scientific Research Project of The Educational Department of Liaoning Province LQGD2019004 and State Key Laboratory of Reliability and Intelligence of Electrical Equipment in Hebei University of Technology EERIKF2019010.

ABSTRACT In order to monitor loosened state and deformational fault for transformer winding, the monitoring method based on vibration and reactance information is proposed in this paper. Theoretical models of winding deformational state with vibration and reactance information are established and calculated. Multi-information monitoring model is established, which include vibration and reactance information monitoring method. Multi-information integrated monitoring strategy is proposed. The CEEMD-energy entropy transformation method is proposed to extract vibration feature information, and reactance feature information is extracted by reactance identification method. Aiming at a 500kVA, 35kV transformer prototype, experiment of short circuit current impact is carried on, three types of deformational windings including radial extend in middle position, axial stretching loosened and coil folding in end position are developed. Monitoring experiment on loosened state winding after multi-short circuit current impacts and three types of deformational fault windings are carried on. The monitoring results are consistent with the actual deformational state of transformer windings. Loosened state and deformational fault of windings can be monitored by proposed monitoring method based on vibration and reactance information effectively, which provide basis for multi-information monitoring.

INDEX TERMS transformer winding; Loosened state; deformational fault; vibration information; reactance information;

I. INTRODUCTION

With the development of the smart grid, higher requirements are put forward for operation reliability and state monitoring technology of transformers[1-2]. Previous research indicate, the winding of transformer will be severe deformation due to the multi impacts of short circuit current[3-5]. The insulation level of the transformer will be reduced, which will finally cause equipment to be burn down, transformer to be explosion, power interruption in substations and other severe power accidents[6-7]. Therefore, many scholars calculate the amplitude and distribution characteristic of electromagnetic force in the transformer under the condition of short circuit current[8-9], and study the effect of short circuit current impacts on the deformation mechanism and mechanical strength of transformer winding[10-11].

According to research of winding deformation mechanism[12-13], deformational state of winding includes loosened state and deformational fault. The deformational fault

of winding is not instantaneous, but a process of gradual deterioration. Before the severe deformational fault of winding, there will be a early latent fault, namely winding loosened state. Although deformational fault does not occur in winding at this stage, the compression force has become obviously loosened, the ability to resist short circuit current impacts has been decreased significantly, which will cause the severe deformational fault under a long time of operation[14-15]. Therefore, monitor method for early latent loosened state and severe deformational faults of winding are urgently needed, in order to master the operation state of winding in whole life cycle, avoid sudden fault of transformer, improve the monitoring accuracy of transformer and the maintenance efficiency of power system.

In the field of deformational state monitoring of transformer winding, the conventional methods such as frequency response, low voltage pulse and short circuit reactance are generally accepted by operation departments in

power system[16-18]. Frequency response and low voltage pulse method have been widely used in the power industry, they are mainly be tested after the transformer quit operation in actual application[19-20]. Although short circuit reactance method can be used to monitor the winding deformation online[21], it cannot diagnose the early latent fault of winding loosened state. Recently, state monitoring method based on vibration information is becoming one of the research directions in transformer winding monitoring field[22-24]. Liu et al. [25] established the dynamic model of transformer winding based on finite element method, calculated the magnetic field distribution and axial electromagnetic force of winding in the condition of short circuit, and studied the influence of compression force on winding vibration. Zhang et al. [26] established a operation analysis model of transformer winding modal, vibration signal was obtained under random excitation, aiming at a transformer prototype, the change rule of natural modal after winding deformation was studied. Zheng et al. [27] built the electrical-mechanical dynamic model of the transformer windings, Lipschitz criterion was put forward to monitor the windings fault based on change rule of vibration, and the deformational fault of a winding prototype was diagnosed by testing and analyzing the current and vibration signal characteristics of transformer.

To sum up, short circuit resistance method consider the transformer as a circuit network, and identify deformational fault by analyzing the changes of circuit parameters corresponding to winding structure, but it cannot diagnose the winding loosened state caused by loosened compression force. The vibration information monitoring method considers the windings as a mechanical kinetic model[28-30]. By monitoring the vibration signal, the changes of parameters such as the compression force and electromagnetic force can be diagnosed. However, no matter the winding is loosened state or deformational fault, the compression force will be changed [3], so further research is still needed to distinguish the latent loosened state from deformational fault of the winding by vibration information.

This paper proposes monitoring method on loosened state and deformational fault of transformer winding. The

vibration information is calculated by proposed CEEMD - energy entropy transformation method. Normal state or abnormal state (loosened state or deformational fault) of winding can be diagnosed in established vibration information monitoring model. Aiming at abnormal state of winding, reactance identification calculation method is studied, and winding loosened state or deformational fault can be diagnosed in established reactance information monitoring model. In order to realize and verify the proposed monitoring method, the monitoring system of winding deformational state is developed. Multi-short circuit current impacts experiment are carried out on transformer, three kinds of deformational fault windings are designed. Finally, monitoring experiment on loosened state and deformational fault of transformer winding are carried out, in order to monitor the loosened state and deformational fault of winding in whole life cycle, and provide guidance for the safe operation of the transformer.

II. THEORETICAL MODEL OF WINDING DEFORMATIONAL STATE

In this paper, the S11-M-500/35 transformer is taken as the research object. The main parameters of the transformer model are shown in Table 1. By establishing and solving the mathematical equations and the simulation model of the relationship between winding deformational state with vibration and reactance information, the principle of correlation between winding deformational state with vibration and reactance information are studied. The simulation model of transformer winding is shown in Fig. 1.

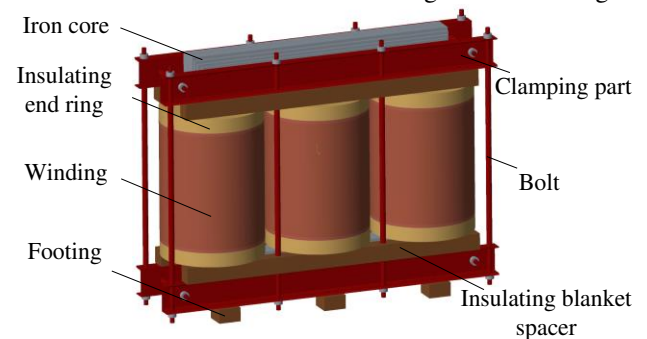

FIGURE 1. The simulation model of transformer

TABLE 1. Parameters of S-11-M-500/35 transformer

Project	Value	Project	Value
Capacity	500kVA	Vector group	Yyn0
Rated current	11.67A/1020.64A	Rated voltage	35000V/400V
Impedance voltage	6.63%	Load loss	6937W
No-load current	0.4 A	No-load loss	0.39 W
Inner diameter of secondary winding	206mm	Inner diameter of primary winding	295mm
External diameter of secondary winding	251 mm	External diameter of primary winding	368mm
Height of secondary winding	403mm	Height of primary winding	425mm
Turns of secondary winding	24	Turns of primary winding	2202
Resistance of secondary winding	1.541E-3Ω	Resistance of primary y winding	16.29Ω

A. MATHEMATIC MODEL AND SOLUTION OF LOOSENED WINDING WITH VIBRATION INFORMATION

The current pass through winding of the transformer will generate periodic vibration signal in the leakage magnetic field, which will be transmitted to the box wall through the

connection of liquid cooling medium and solid. According to the structural characteristics of the transformer windings, the mechanical kinetic model of winding is established, as shown in Fig. 2. Considering such factors as circuit, magnetic field, coil structure, insulation stiffness coefficient and dielectric

damping, the equivalent mathematical equation of winding motion can be derived as follows:

$$F_i = IB'2\pi R = kI^2 \left(\frac{1}{2} + \frac{1}{2} \cos 2\omega t \right) \quad (1)$$

$$M \frac{d^2 S}{dt^2} + C \frac{dS}{dt} + K'S = F' + Mg \quad (2)$$

$$C = \sum_{i=1}^{n+1} C_1 \quad (3)$$

$$K' = K_1 + K_2 \quad (4)$$

$$F' = \sum_{i=1}^n F_i \quad (5)$$

$$M = \sum_{i=1}^n m \quad (6)$$

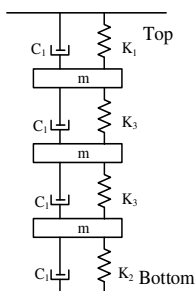

FIGURE 2. The winding mechanical kinetic model

Where F_i is the axial electromagnetic force received by the winding along the direction of winding reactance height, I is current in per phase winding, k is the coefficient of electromagnetic force received by coil in proportion to the current, K_1 and K_2 are the equivalent stiffness coefficient of the insulating material in both ends coils near the yoke clamp of the iron core, K' is the sum of equivalent stiffness coefficient of the insulating material in both ends coils, K' is influenced by compression forces mainly, C is the damping parameter of the cooling medium between the windings, B is the magnetic density component along the radial direction of the winding, S is the displacement of the winding vibration along the axial direction of winding reactance height, F' is the total electrical force applied to the winding along the axial height of the reactance, M is the total mass of the winding.

By solving the above equations, the vibration acceleration of the coil can be calculated as,

$$a = \frac{d^2 S}{dt^2} = -\omega_0^2 Y e^{-\frac{Ct}{2M}} \sin(\omega_0 t + \theta) - 4\omega^2 G \sin(2\omega t + \psi) \quad (7)$$

Where Y and θ are integration constant,

$$\omega_0 = \sqrt{\frac{K}{M} - \left(\frac{C}{2M}\right)^2}, \quad \psi = \arctan\left(\frac{-2C\omega}{K - 4M\omega^2}\right),$$

$$G = \frac{kI^2}{\sqrt{(K - 4M\omega^2)^2 + 4C^2\omega^2}}$$

According to mathematical equation of winding vibration and the main parameters in Table 1, the vibration model of the transformer winding is established as shown in Fig. 1. Under the experimental condition of rated load (short circuit is on the secondary side of the transformer, and the voltage is applied on the primary side, the current on the secondary side increases to the rated load current), the winding vibration of transformer model is solved. Firstly, the peripheral simulation circuit of three-phase windings is established as shown in Fig 3. The load current curves of three-phase high-voltage and low-voltage windings are calculated in the Fig 4.

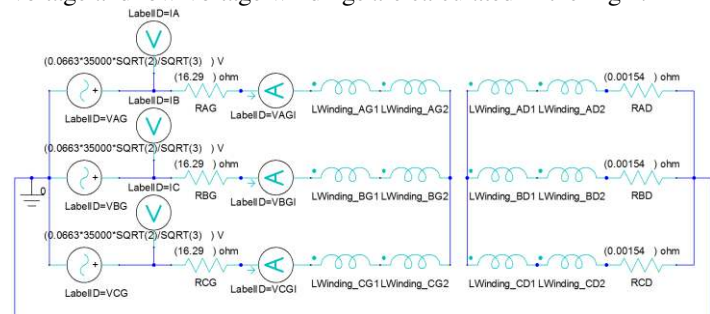
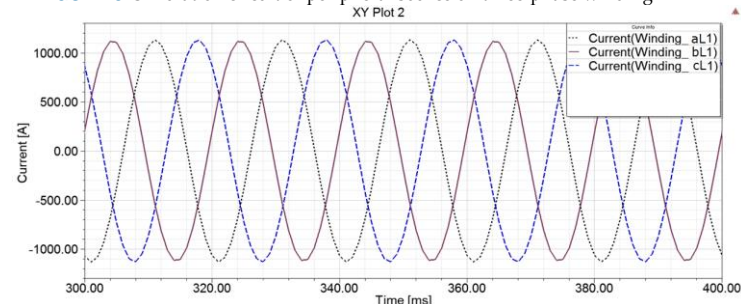
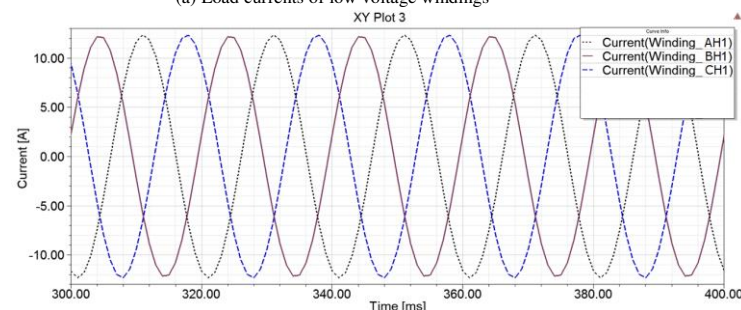

FIGURE 3. Simulation circuit of peripheral source on three-phase winding



(a) Load currents of low-voltage windings



(b) Load currents of high-voltage windings

FIGURE 4. Load current curves high-voltage and low-voltage windings

As is shown in Fig.4, under the rated load condition, the current amplitude of three-phase low-voltage winding are 1074.73A, 1060.15A and 1075.98A respectively, the current amplitude of three-phase high-voltage winding are 12.32A, 12.13A and 12.30A respectively. The phase difference of the three - phase current is 120 degree angle. The accuracies of calculation results exceed 94.43%. The calculated results are in good agreement with the actual

parameters of transformer. Then the vector distribution of electromagnetic force in windings is further solved, as shown in Fig.5. The calculated results in Fig.5 shows that, the electromagnetic force of high and low voltage windings are opposite in direction, which will cause in mutually exclusive effects between high and low voltage windings.

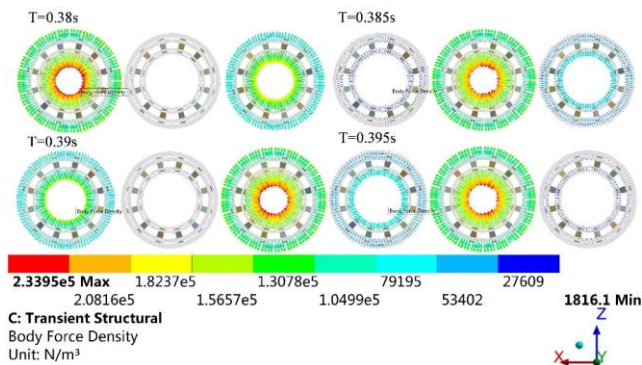

FIGURE 5. The electromagnetic force density vector diagram

Finally, the vibration signal of winding under electromagnetic force are calculated. In order to research the changing law of winding vibration during the loosening process of compression force, the end compression force is loaded in the transformer winding vibration model, as shown in Fig 6. Under four compression forces of 2000N, 1750N, 1500N and 1250N, vibration signals at end position of transformer winding are calculated respectively. The vibration measuring point at the end position of winding model is shown in Fig. 7. And the variation characteristics of vibration information at end position of winding after loosened compression force are calculated in Fig. 8.

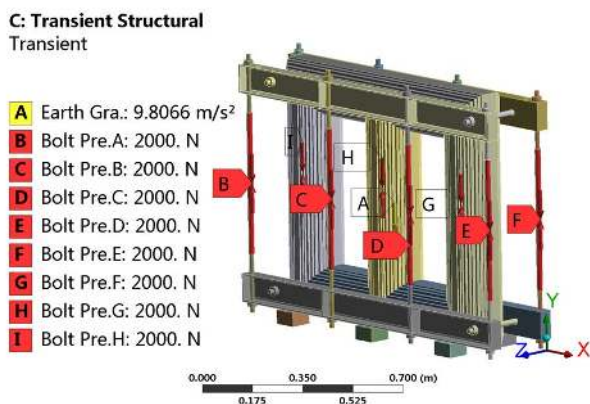

FIGURE 6. Compression force on winding vibration model

As can be seen from Fig. 8, the acceleration of the winding vibration signal increases significantly with the decrease of the end compression force in winding, the vibration information changes with the winding loosened state. According to the established mathematical relationship model of winding loosened state with vibration information, and the calculated result of simulation model, the vibration information is related to the load current, the elastic coefficient of insulating material, the quality of

winding and the damping medium. When the load current, medium damping and other parameters remain unchanged, the vibration information is mainly affected by the equivalent stiffness coefficient of the end insulation material and the end compression force. Therefore, by monitoring and analyzing the vibration information, the winding loosened state caused by loosened compression force can be diagnosed.

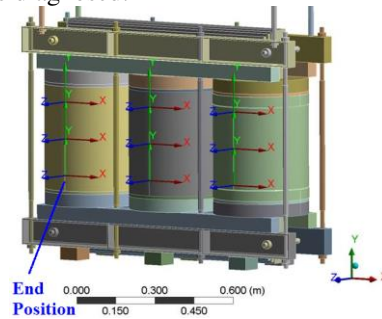

FIGURE 7. The vibration measuring point at end position of winding model

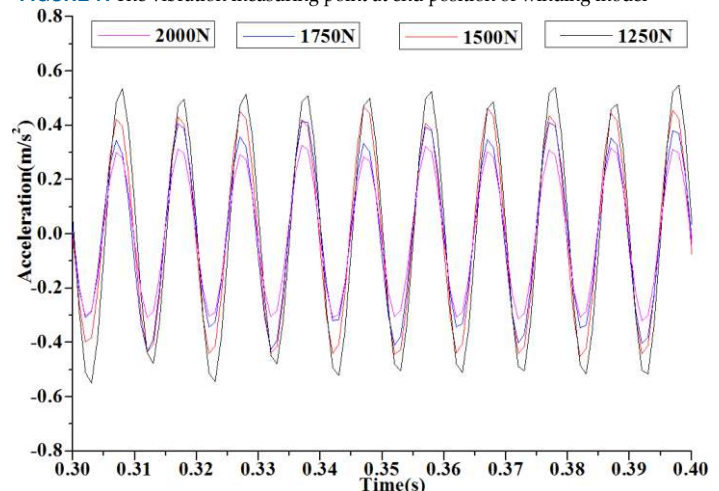

FIGURE 8. Vibration calculation results in different compression forces

B. MATHEMATIC MODEL AND SOLUTION OF DEFORMATIONAL WINDING WITH REACTANCE INFORMATION

The short circuit reactance of power transformers is an important index to represent the deformational fault of windings. The principle is that, both the leakage inductance and short circuit reactance of transformers are affected by the deformational parameters such as the size, space position and inter-turn distance of the coils. The short circuit reactance calculation mathematical model is established by magnetic field energy method as,

$$W_s = \frac{1}{2} L_k I^2 = \frac{1}{2\mu_0} \int_V B^2 dV \quad (8)$$

$$X_k = 2\pi f L_k = \frac{2\pi f \mu_0}{I^2} \int_V H^2 dV \quad (9)$$

Where μ_0 is the permeability of free space, X_k is short circuit reactance, L_k is leakage inductance, B is the flux

density, H is magnetic field intensity, f is the current frequency.

Aiming at concentric transformer, structure of winding is shown in Fig.9. Where L_1 and L_2 are thicknesses of secondary and primary winding, L_3 is thicknesses of gap between secondary and primary winding, r_1 is the distance from secondary winding axis to core, r_2 is the distance from primary winding axis to core, r_3 is the distance from gap axis of secondary and primary winding to core, l is height of winding.

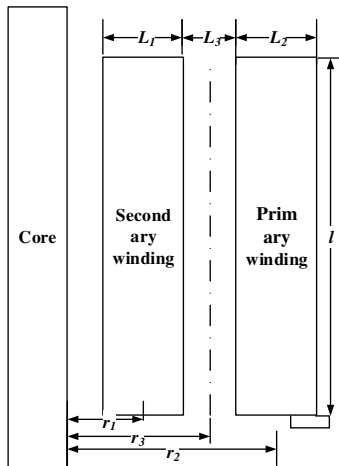

FIGURE 9. Structure of transformer winding

The equivalent reactance height parameter of transformer winding is introduced as,

$$l' = \frac{l}{1 - \frac{L_1 + L_3 + L_2}{\pi d}} \quad (10)$$

For calculating short circuit reactance, the winding integral space is divided into three sections. According to the axial symmetry equivalent integral principle, magnetic field energy is calculated by integral along circumferential direction of winding cylinder in the unit length. The three sections are as follows: section 1 (secondary winding area), section 2 (primary winding area) and section 3 (the area of oil gap between primary and secondary winding). The equivalent mathematical model of the relationship between winding deformational fault and reactance information can be established.

The volume integral of H^2 in the area of oil gap between primary and secondary side winding is,

$$\int_V H^2 dV = \frac{2\pi n^2 I_N^2}{l'} L_3 r_3 \quad (11)$$

The volume integral of H^2 in primary and secondary side winding areas are,

$$\int_V H^2 dV = \frac{2\pi n^2 I_N^2}{l'} \frac{1}{3} L_2 \left(r_2 + \frac{3}{4} L_2 \right) \quad (12)$$

$$\int_V H^2 dV = \frac{2\pi n^2 I_N^2}{l'} \frac{1}{3} L_1 \left(r_1 - \frac{3}{4} L_1 \right) \quad (13)$$

Add the three above equations and substitute result into formula (9), mathematical model of short circuit reactance can be obtained as,

$$X_k = f\mu_0 n^2 \frac{4\pi^2}{l'} \left(\frac{L_1 r_1 + L_2 r_2}{3} + L_3 r_3 \right) \quad (14)$$

The mathematic model shows that short circuit reactance is related to the structural parameters of winding. The deformation can change structural parameters and leakage inductance of winding, and change short circuit reactance finally.

According to the above mathematical equations of winding reactance, the relation and change rule between winding deformational fault with reactance can be studied by solving the magnetic field distribution inside the winding space position of transformer. Based on main parameters in Table 1, the finite element calculation model of transformer windings magnetic field is established as shown in Fig. 10 (a). Fig. 10 (b) and 10 (c) are partial subdivision results of normal winding and amplitude deformational winding respectively. Under the experimental condition of rated load, the distribution and the amplitude of leakage magnetic field for the normal and deformational winding are calculated as shown in Fig. 11.

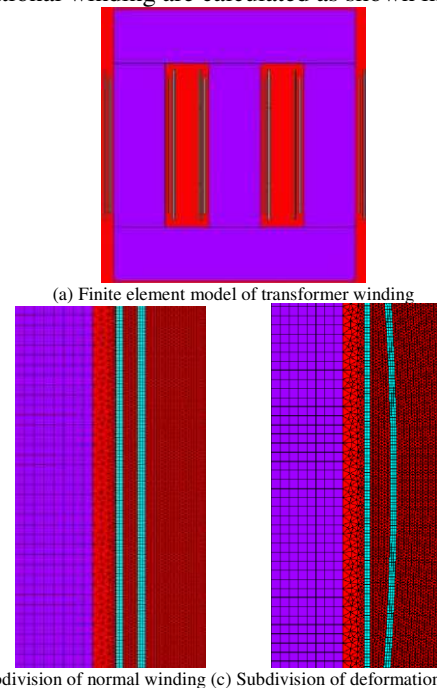

(a) Finite element model of transformer winding
(b) Subdivision of normal winding (c) Subdivision of deformational winding
FIGURE 10. Finite element simulation model of transformer winding

As shown in the magnetic field calculation results of the finite element model from Fig. 11, the distribution of magnetic leakage field in the transformer space changes after winding deformation. Compared with the normal windings, the maximum magnetic flux density increases after winding deformation. According to the mathematical model and the solution results, when the deformational fault occurs in windings, the spatial distance parameters between the core and the winding will change, which can change the distribution of leakage magnetic field. As can be seen from equation (8) - (14), the reactance information of the

transformer windings will also change accordingly. Therefore, the reactance information of transformer is mainly affected by the deformational degree of winding. By detecting and identifying the reactance information of the transformer, winding deformational fault can be monitored.

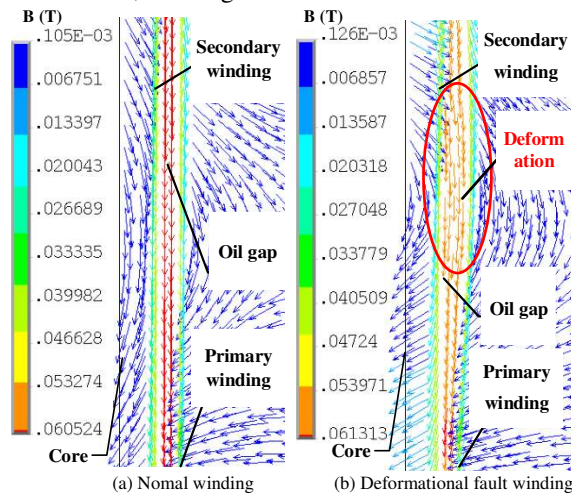

FIGURE 11. Magnetic field results for normal and deformational windings

III. MONITORING METHOD ON LOOSENED STATE AND DEFORMATIONAL FAULT OF TRANSFORMER WINDING

A. MONITORING METHOD OF VIBRATION INFORMATION

The vibration signal of transformer winding contain a wealth of state information. By extracting and analysing the vibration information and variation rules, deformational state of winding can be monitored. In order to extract the characteristics of deformational state for transformer winding accurately, complete ensemble empirical mode decomposition (CEEMD) method is proposed to eliminate the residual auxiliary noise in reconstructed signals, and maintain the characteristics of original signal. The specific decomposition steps and principles of CEEMD method are as follows:

I white noises are added to the original signal in the form of positive and negative pairs, and $2I$ signals can be obtained, that is,

$$\begin{bmatrix} x_+ \\ x_- \end{bmatrix} = \begin{bmatrix} 1 & 1 \\ 1 & -1 \end{bmatrix} \begin{bmatrix} x \\ \omega_i \end{bmatrix} \quad (15)$$

Each signal in the set is decomposed by empirical mode decomposition respectively, signal $IMF_n^i[n]$ can be obtained. The first intrinsic mode function (IMF) is calculated as,

$$IMF_1[n] = \frac{1}{2I} \sum_{i=1}^{2I} IMF_n^i[n] \quad (16)$$

The first remaining component is,

$$r_1[n] = x[n] - IMF_1[n] \quad (17)$$

The k remaining component can be calculated as,

$$r_k[n] = r_{(k-1)}[n] - IMF_k[n] \quad (18)$$

Then the decomposed function becomes $r_k[n] + \varepsilon_k E_k(\omega_i[n])$, new intrinsic mode function (IMF) is calculated as,

$$IMF_{(k+1)}[n] = \frac{1}{2I} \sum_{i=1}^{2I} E_1[r_k + \varepsilon_k E_k[\omega_i[n]]] \quad (19)$$

Repeat (18)-(19) until the calculation terminates, calculated result of CEEMD method is,

$$x[n] = \sum_{k=1}^k IMF_1[n]_k + R[n] \quad (20)$$

Where coefficient ε_k is signal-to-noise ratio.

After a series of calculations, a set IMF signal can be obtained. This method can extract original signal characteristics according to the energy spectrum distribution of decomposition layer effectively.

When the loosened state or deformational fault occurs in transformer windings, the energy distribution of each IMF component obtained by CEEMD method will also change accordingly. Therefore, CEEMD method and energy entropy theory are fused in this paper. The energy distribution is calculated by CEEMD method of winding vibration signal, and energy entropy of each IMF component is extracted as the vibration information for monitoring the deformational state of transformer winding.

The original vibration signal $x[n]$ of transformer winding can be decomposed by CEEMD method to obtain n IMF components and a residual component r_n . The signal energy of IMF component is calculated as,

$$E_i = \int_{t_{i-1}}^{t_i} |A_i(t)|^2 dt \quad (21)$$

Where $A_i(t)$ is vibration signal amplitude of IMF component, $i=1,2,\dots,n$.

The energy value is normalized. The normalized formula of the vibration signal energy of IMF components is,

$$p_i = \frac{E_i}{\sum_{i=1}^n E_i} \quad (22)$$

Since CEEMD is orthogonal, the sum of IMF components energy should be equal to the total energy of the original vibration signal. IMF components contain different energy components, so the energy distribution set of vibration signal for transformer winding is calculated as $E = \{E_1, E_2, \dots, E_n\}$. Therefore, the energy entropy of IMF components calculated by CEEMD can be defined as,

$$H_{EN} = -\sum_{i=1}^n p_i \log p_i \quad (23)$$

B. MONITORING METHOD OF REACTANCE INFORMATION

The short circuit reactance of power transformer is mainly affected by the winding structure parameters, which can represent deformational fault of winding effectively. When deformational fault occurs in winding, the spatial distance parameters between the core and the winding will change, which will lead to the change of reactance value. Therefore, this paper proposes the reactance identification calculation method to monitor the reactance information of transformer. In order to study the mathematics mechanism of transformer electrical parameters, a double-winding model is established according to the T-type circuit solution principle of transformer reactance information, as shown in Fig. 12.

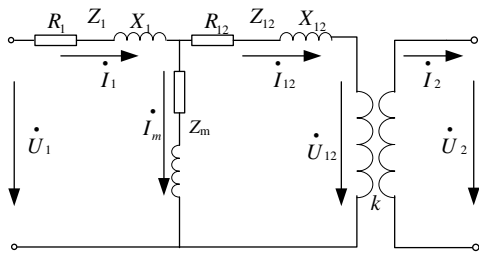

FIGURE 12. Equivalent circuit model

Where R_1 and X_1 are resistance and reactance of primary winding; R_{12} and X_{12} are equivalent resistance and reactance of secondary winding. \dot{U}_1 and \dot{U}_2 are voltage of primary and secondary winding. \dot{I}_1 and \dot{I}_2 are current of primary and secondary winding. \dot{U}_{12} and \dot{I}_{12} are equivalent voltage and current of secondary winding. k is the ratio of primary and secondary coil turns.

The mathematical equation of the T-type circuit is,

$$\frac{\dot{U}_1 - k\dot{U}_2}{\dot{I}_1} = Z_1 + \frac{\dot{I}_2}{k\dot{I}_1} Z_{12} \quad (24)$$

$$R_1 + jX_1 = Z_1 \quad (25)$$

$$R_{12} + jX_{12} = Z_{12} \quad (26)$$

Four parameters (m , n , a , b) are introduced for complex transformation as,

$$\frac{\dot{U}_1 - k\dot{U}_2}{\dot{I}_1} = m + jn \quad (27)$$

$$\frac{\dot{I}_2}{k\dot{I}_1} = a + jb \quad (28)$$

The vector-value of voltage and current under two loads are monitored, real part m and a , imaginary part n and b can be calculated based on corresponding formulas (24) - (28). By establishing the following identification matrix, the reactance value X_1 of primary winding and the equivalent reactance value X_{12} of secondary winding can be solved as,

$$\begin{pmatrix} 1 & 0 & a_1 & -b_1 \\ 0 & 1 & b_1 & a_1 \\ 1 & 0 & a_2 & -b_2 \\ 0 & 1 & b_2 & a_2 \end{pmatrix} \begin{pmatrix} R_1 \\ X_1 \\ R_{12} \\ X_{12} \end{pmatrix} = \begin{pmatrix} m_1 \\ n_1 \\ m_2 \\ n_2 \end{pmatrix} \quad (29)$$

Short circuit reactance of transformer winding can be calculated as reactance information,

$$X_k = X_1 + X_{12} \quad (30)$$

For transformer windings in different state, the change rate of reactance information can also be calculated to diagnose the winding deformational fault, that is,

$$X_k \% = \frac{|X_k - X|}{X} \quad (31)$$

Where $X_k\%$ is change rate of reactance information, X is initial nameplate value of reactance information.

C. MONITORING METHOD BASED ON VIBRATION AND REACTANCE INFORMATION

In the practical application of monitoring method of winding deformational state, short circuit reactance is an important index to reflect the winding deformation. After years of popularization and application, the quantitative diagnosis standard of short circuit reactance has been formed. However, short circuit reactance cannot reflect the latent fault of winding loosened state. The vibration signal can reflect the latent fault of winding loosened state, but it can't distinguish winding loosened state from severe deformational fault. Moreover, the application of vibration information monitoring method on the winding deformational state also needs the auxiliary quantitative diagnosis standard of reactance information monitoring method.

Therefore, monitoring method on loosened state and deformational fault of transformer winding is proposed. Multi-information monitoring model is built which includes vibration and reactance information monitoring method, as shown in Fig. 13. The integrated monitoring strategy of monitoring model is proposed as follows: firstly, the winding vibration signal data is obtained in the vibration information monitoring model. Eight *IMF* components of vibration signal data are extracted by CEEMD method. The normalized energy distribution of the *IMF* components is calculated, and the energy entropy of *IMF* components after CEEMD on the vibration signal is solved as the vibration information based on formula (15) - (23). Compare with the diagnosis threshold: if the vibration information is greater than diagnosis threshold, winding is in a normal state. If the vibration information is less than diagnosis threshold, the winding is diagnosed to be abnormal state, namely, the winding may be loosened state or deformational fault.

Then the reactance information monitoring model is established to diagnose the winding loosened state or deformational fault. The first current and voltage vector data set of the primary and secondary side windings are collected. The power factor angle $\cos\phi_1$ is solved. After changing load of transformer, the second current and

voltage vector data set of the primary and secondary side windings are collected. The power factor angle $\cos\phi_2$ is solved. The short circuit reactance of transformer winding is identified and calculated by formula (24) - (31) as the reactance information. The change rate of reactance information is solved according to the initial nameplate value. Compare with the short circuit reactance diagnosis standard specified in the IEC 60076-5[31]: if the change rate of reactance information is less than the diagnosis standard value, the winding is diagnosed to be loosened state. If the change rate of reactance information is greater than the diagnosis standard value, the winding is diagnosed to be deformational fault. Based on the monitoring results of vibration and reactance information monitoring models, the loosened state and deformational fault of winding can be monitored effectively.

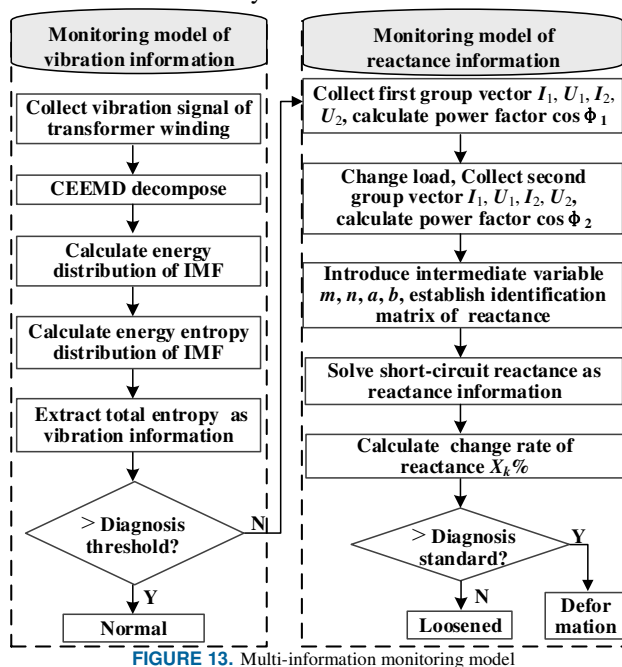
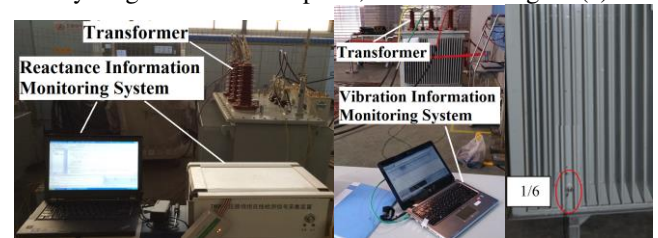

FIGURE 13. Multi-information monitoring model

IV. DEVELOPMENT OF STATE MONITORING SYSTEM AND TRANSFORMER PROTOTYPE

In order to construct the vibration and reactance information data set corresponding to the normal, loosened state and deformational fault of transformer winding, aiming at a 500kVA, 35kV transformer, multi-information monitoring system of winding deformational state is designed. Experiment of short circuit current impacts is carried on, three kinds of deformational windings including radial extension in middle position, axial stretching loosened and coil folding in end position are developed. The experimental prototype of normal winding, loosened winding after multi-short circuit impacts and deformational fault winding are designed respectively. Under the rated load experimental condition, the test experiment of transformer winding prototype in different state are carried out. The reactance information monitoring system mainly includes transformer module, limiter circuit module, digital-analog synchronous sampling module and reactance

information analysis module. The vibration information monitoring system includes acceleration sensor module, synchronous sampling module, communication module and vibration information analysis module. The vibration information monitoring system adopts 10-32UNF coaxial cable and JP0145BNC interface to transmit data. The test site of reactance and vibration information is shown in Fig. 14 (a) and 14 (b). In order to monitor the loosened state in winding end, and avoid noise interference effectively, the vibration sensor is installed on 1/6 test point of the oil tank surface directly corresponding to the transformer winding end by magnetic seat adsorption, as shown in Fig.14 (c).



(a) Reactance test site (b) Vibration test site (c) Vibration test point

FIGURE 14. State monitoring system and test experiment site

In order to obtain the diagnosis threshold of monitoring model, multi-short circuit current impacts experiment are carried out on the A-phase winding under the conditions of 60%, 85% and 100% percentages of short circuit impact current (the peak of short circuit impact current is 32.6 times of rated load current). The short circuit current impacts experiment site is shown in Fig. 15 (a). Hanging core inspection is carried out on the windings after short circuit current impacts to obtain the winding loosened state. Hanging core inspection site on the windings after short circuit current impacts is shown as in Fig. 15 (b). According to Fig. 15 (b), the severe deformational fault does not occur in the A-phase winding after multi-short circuit current impacts experiment. However, hanging core inspection result shows that the end block of the A-phase winding have been shifted and loosened, that is, the end clamping force of the A-phase winding have become loosened. In rated load current condition, the vibration signal data of loosened state winding after multi-short circuit current impacts experiment is shown in Fig. 16. CEEMD-energy entropy transformation method is proposed, normalized energy distribution of *IMF* components in winding loosened state is calculated in Table.2. Energy entropy of *IMF* components in winding loosened state is calculated in Table.3. Based on equations (15) - (23), vibration information diagnosis threshold of such transformer winding loosened state is calculated as 0.5529.

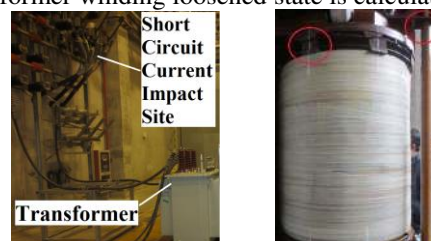

(a) Short circuit current impacts experiment (b) Inspection result of winding

FIGURE 15. Short circuit current impacts experiment and inspection result

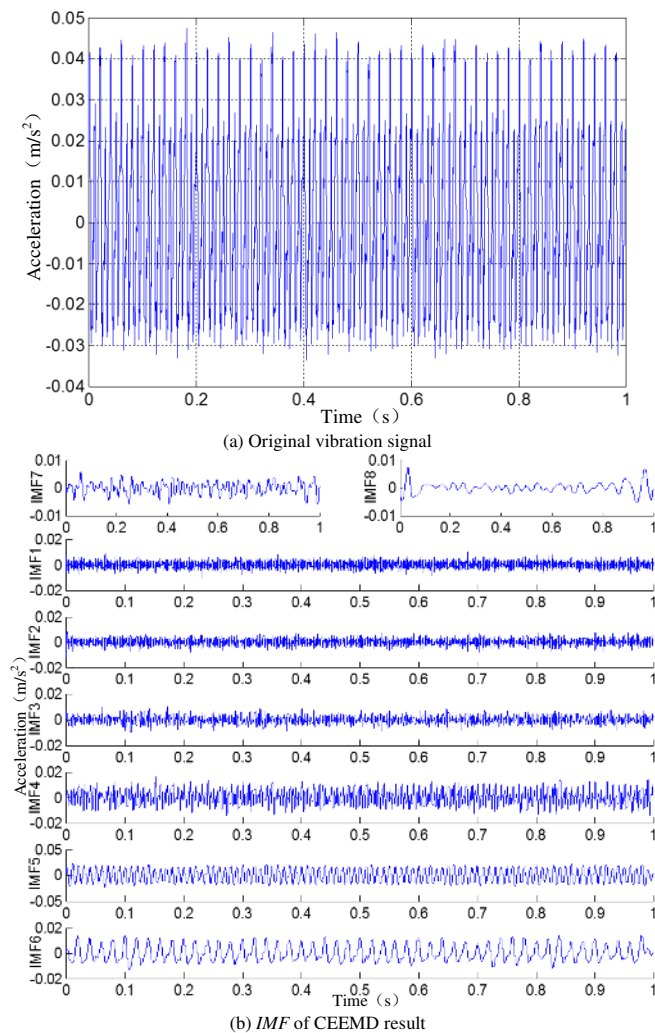

FIGURE 16. Vibration signal and CEEMD result in winding loosened state

TABLE 2. Energy distribution of IMF in winding loosened state

Loosened state	Normalized energy distribution of eight IMF components							
	p_1	p_2	p_3	p_4	p_5	p_6	p_7	p_8
Value	0.01	0.02	0.03	0.13	0.60	0.16	0.01	0.01
Count	8172	1436	2119	233	0919	0316	9571	5138

TABLE 3. Energy entropy of IMF in winding loosened state

Loosened state	Energy entropy of eight IMF components							
	H_1	H_2	H_3	H_4	H_5	H_6	H_7	H_8
Value	0.05	0.06	0.08	0.08	0.15	0.14	0.04	0.02
Count	5505	899	0096	1199	3488	9099	7585	9951

According to the common deformational fault types statistics of transformer winding, three kinds of deformational fault windings are designed: radial extension in the middle position, axial tension loosened and coil folding in end position. Design basis and process of three kinds of deformational fault windings are as follow: (1) The current direction in the primary and secondary windings of the transformer will produce mutually exclusive electromagnetic force in them, which will decrease the radius of secondary side winding and increase the radius of primary side winding at the middle position. Therefore, the fault winding of radial extension in the middle position is designed. (2) Aiming at a large-capacity transformer, once

the short circuit current passes through the winding, the huge electromagnetic force produced by short circuit current will make the end block and insulation rod of the winding to be shifted and loosened, so the fault winding of axial tension loosened is designed by pulling out wedge and end insulation. (3) For the aged transformer operating for a long time, under the combined action of electromagnetic force and end clamping force, coils often become overlapped in upper and lower end positions of winding. Therefore, the fault winding of coil folding in end position is designed. The designed three kinds of deformational fault windings are shown in Fig. 17. According to diagnosis standard of short circuit reactance specified in the IEC 60076-5[31], diagnosis standard of reactance information change rate for such deformational fault winding is 2%.

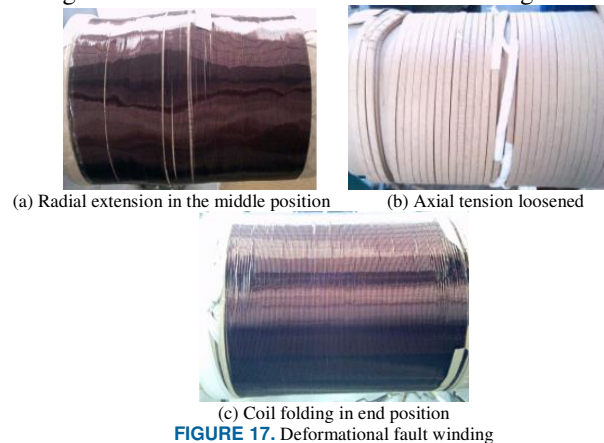

FIGURE 17. Deformational fault winding

V. MONITORING EXPERIMENT OF WINDING

A. MONITORING EXPERIMENT OF WINDING LOOSENED STATE

In order to monitor the winding loosened state, analyze the vibration and reactance information data under winding loosened state, and study the changing trend of the vibration and reactance information after short circuit current impacts on transformer. Aiming at a 500kVA, 35kV transformer winding withstand multi-short circuit current impacts, monitoring experiment on loosened state of transformer winding is carried out based on the monitoring method proposed in this paper.

Firstly, establish the vibration information monitoring model, the vibration signal test experiment on the normal winding and the winding after multi-short circuit impacts are carried out under rated load condition. Vibration signal of the normal winding and the winding after multi-short circuit impacts are obtained in Fig. 18 (a) and Fig. 19 (a). According to Fig. 18 and 19, the time-domain amplitude of vibration signal increases significantly, after the winding withstand multi-short circuit current impacts.

Eight IMF components of vibration signal data are extracted by CEEMD method, as shown in Fig. 14 (b) and Fig. 15 (b). The energy entropy of IMF components for the vibration signal of normal transformer winding and the transformer winding after multi-short circuit impacts are

solved as the vibration information, as shown in Table.4. According to Table.4, the vibration information of the normal transformer winding is 0.6659, which is greater than the diagnosis threshold of 0.5529. The vibration information of transformer winding after multi-short circuit impacts is 0.4268, which is less than the diagnosis threshold of 0.5529. The diagnosis result shows that the transformer winding after multi-short circuit impacts is abnormal state, that is, the winding after multi-short circuit impacts may be latent loosened state or deformational fault.

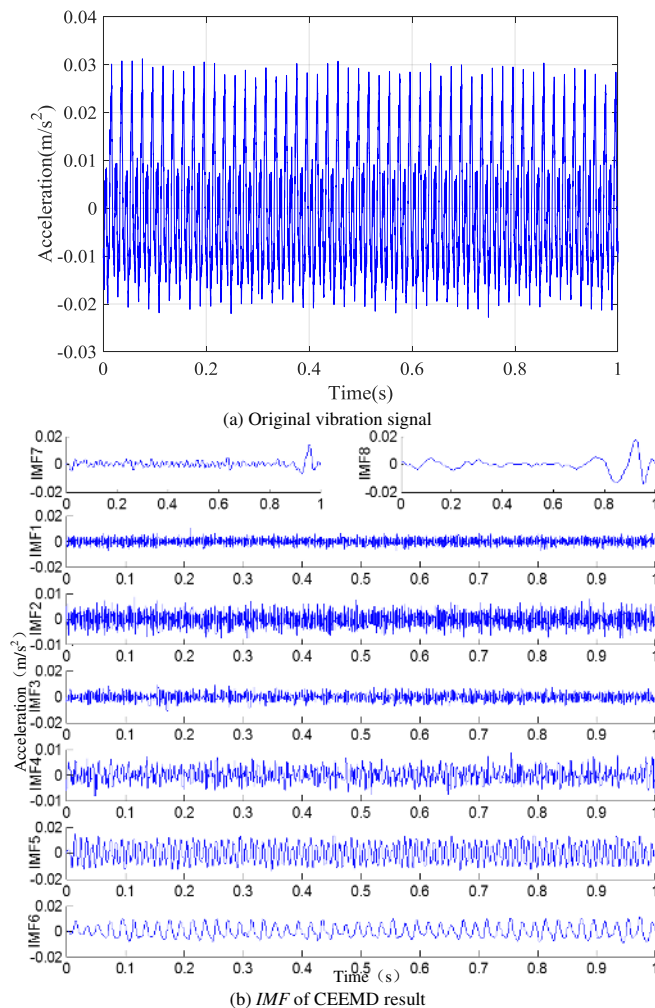

FIGURE 18. Vibration signal and CEEMD result in normal winding state

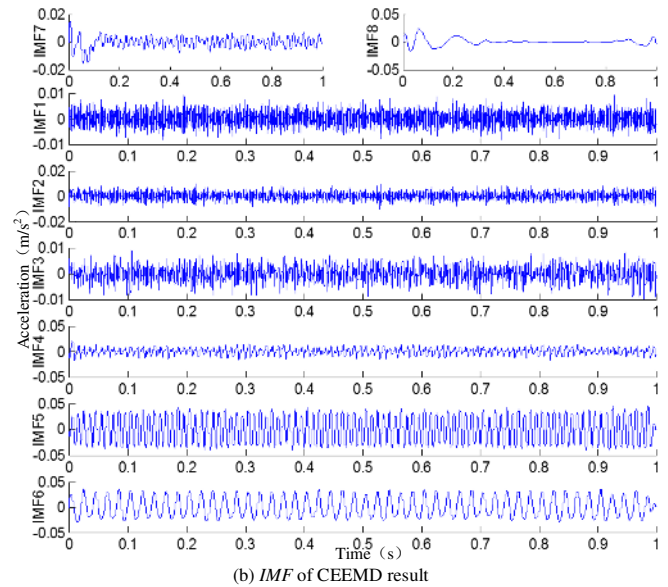
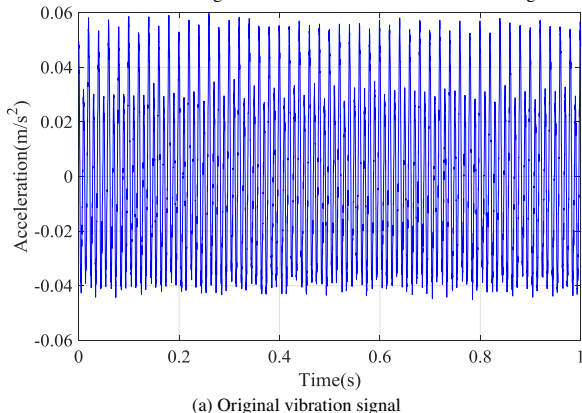

FIGURE 19. Vibration signal and CEEMD result of winding after short circuit current impacts

Then, establish the reactance information monitoring model, the short circuit reactance of transformer winding is identified and calculated, and the change rate of the extracted reactance information is shown in Table.5. According to the data in Table.5, short circuit reactance of normal transformer winding and transformer winding after multi-short circuit impacts are 156.58Ω and 156.73Ω respectively, reactance information change rate of winding after multi-short circuit impacts is 0.096%, which is less than 2% of the diagnosis standard of short circuit reactance specified in the IEC 60076-5[31]. The diagnosis result shows that no deformational fault occurs in winding after multi-short circuit impacts. Combined with the diagnosis results of vibration information monitoring model, it can be compositely diagnosed that the winding of transformer prototype after multi-short circuit impacts has been latent loosened state. In order to verify the accuracy of diagnosis result, the disassembly inspection of the transformer prototype is carried out as shown in Fig.20. The disassembly inspection results show that the winding of transformer prototype after muti-short circuit current impacts is not in deformational fault. However, the screws in the end position of the winding appears to be loosened, that is, the loosened state occurs in end position of winding. The conclusion of disassembly inspection verifies the reliability for the monitoring method based on vibration and reactance information.

TABLE 4. Vibration information and change rates

State	Vibration information	Change rates
Normal winding	0.6659	/
Winding after short circuit current impacts	0.4268	35.91%

TABLE 5. Reactance information and change rates

State	Reactance	Change
-------	-----------	--------

	information	rates
Normal winding	156.58Ω	/
Winding after short circuit current impacts	156.73Ω	0.096%



FIGURE 20. Transformer disassembly inspection experiment

As can be seen from Table.5, when the transformer winding is latent loosened state, compared with the normal winding, the reactance information is almost unchanged, so the latent loosened state of winding cannot be monitored only by reactance information, but the monitoring method proposed in this paper can diagnose the winding loosened state effectively.

B. MONITORING EXPERIMENT OF WINDING DEFORMATIONAL FAULT

In order to study the vibration and reactance information characteristics of the transformer winding under severe deformational fault, based on monitoring method based on vibration and reactance information proposed in this paper, monitoring experiment are made on three kinds of deformational fault windings including radial extension in the middle position, axial tension loosened and coil folding in end position.

Firstly, establish the vibration information monitoring model, the vibration signal test experiment on three kinds of deformational fault windings including radial extension in the middle position, axial tension loosened and coil folding in end position are carried out under rated load condition. Vibration signal of three kinds of deformational fault windings are obtained in Fig .21 (a), Fig .22 (a) and Fig.23 (a). According to Fig. 21-23, when severe deformational fault occur in the winding, the time-domain amplitude of vibration signal increases significantly.

Eight *IMF* components of vibration signal data are extracted by CEEMD method, as shown in Fig .21 (b), Fig .22 (b) and Fig.23 (b). The energy entropy of *IMF* components on the vibration signal of three kinds of windings including radial extension in the middle position, axial tension loosened and coil folding in end position are solved as the vibration information, as shown in Table.6. According to the Table.6, the vibration information of three kinds of windings are 0.2586 、 0.1468 and 0.4672 respectively, those are less than the diagnosis threshold of 0.5529. The diagnosis result shows that three kinds of windings including radial extension in the middle position, axial tension loosened and coil folding in end position are abnormal state, namely, the three kinds of winding may be latent loosened state or deformational fault.

Then, establish the reactance information monitoring model, the short circuit reactance of three kinds of

transformer windings are identified and calculated, and the change rates of the extracted reactance information are shown in Table.7. According to the data in Table.7, short circuit reactance of three kinds of transformer windings are 161.76Ω, 165.37Ω and 171.06Ω respectively. Compared with short circuit reactance value 156.58Ω of normal winding, reactance information change rates of three kinds of transformer windings are 5.61%, 3.31% and 9.25%, those are all greater than 2% of diagnosis standard of short circuit reactance specified in the IEC 60076-5[31]. Combined with the diagnosis results of vibration information monitoring model, it is compositely diagnosed that three kinds of windings of transformer prototypes have been all severe deformational fault. The monitoring results are consistent with actual state of three kinds of windings.

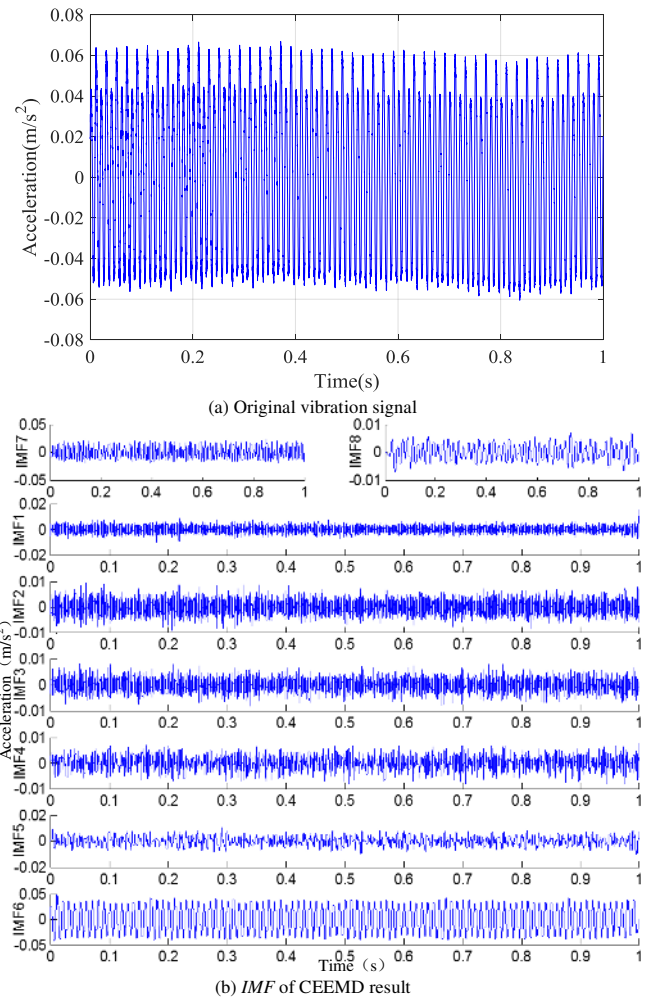

FIGURE 21. Vibration signal and CEEMD result in deformational winding of radial extension in the middle position

TABLE 6. Vibration information and change rates

State	Vibration information	Change rates
Normal winding	0.6659	/
Radial extension in the middle position	0.2586	61.17%
Axial tension loosened	0.1468	77.95%
Coil folding in end position	0.4672	29.84%

TABLE 7. Reactance information and change rates

State	Reactance information	Change rates
Normal winding	156.58Ω	/
Radial extension in the middle position	165.37Ω	5.61%
Axial tension loosened	161.76Ω	3.31%
Coil folding in end position	171.06Ω	9.25%

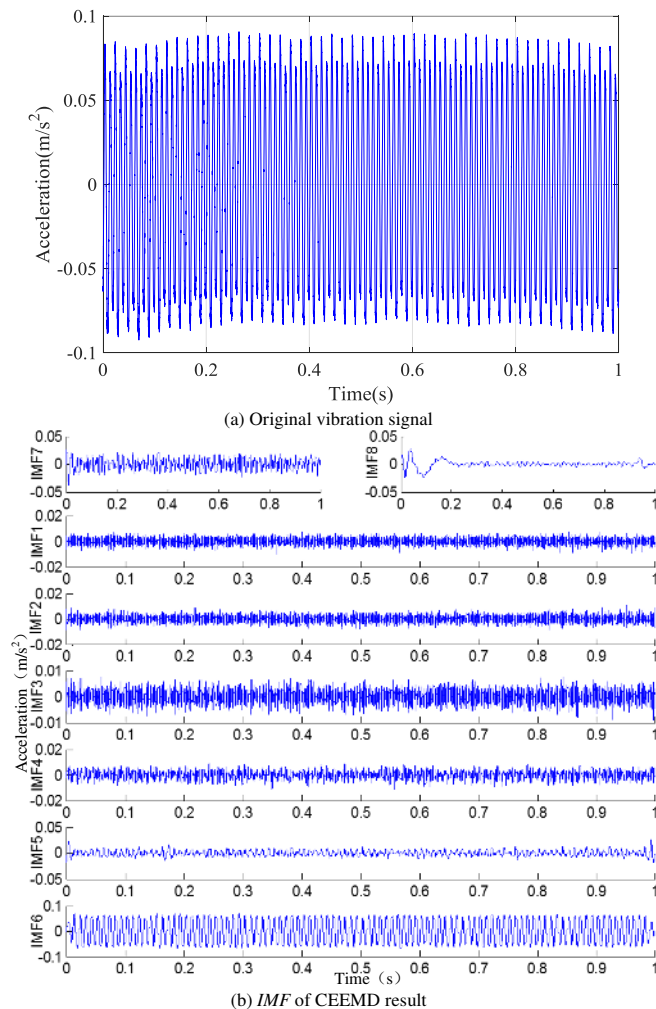

FIGURE 22. Vibration signal and CEEMD result in deformational winding of axial tension loosened

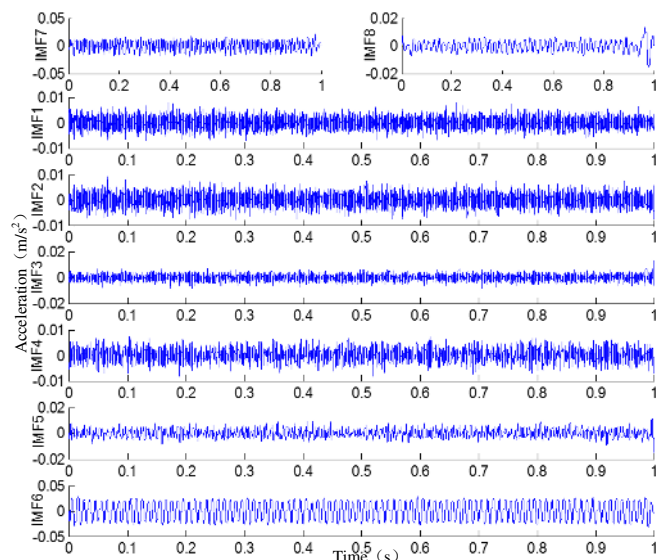
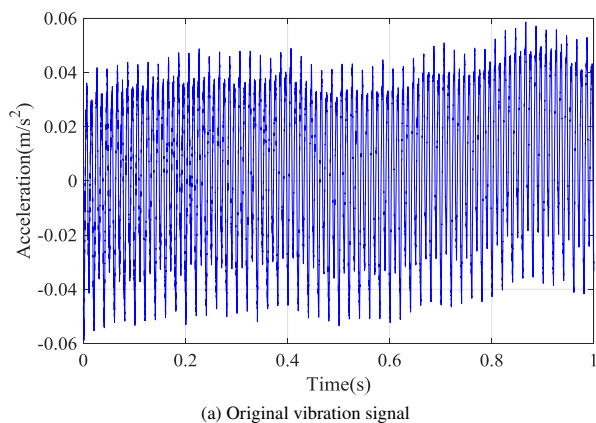

FIGURE 23. Vibration signal and CEEMD result in deformational winding of coil folding in end position

Comparing the vibration information data in Table.4 with Table.6, it can be seen that, although the winding loosened state can be effectively monitored based on the vibration information, the vibration information (0.4268) and change rate (35.91%) of the loosened state winding after short-circuit impacts has exceeded the vibration information (0.4672) and change rate (29.84%) of deformational winding of coil folding in end position. In fact, the winding of coil folding in end position is a severe deformational fault, and its deformational state level is more severe than the loosened winding, the winding is loosened state or severe deformational fault cannot be monitored according to single vibration information. Therefore, single information can't distinguish winding loosened state from severe deformational fault. The monitoring method of transformer winding based on vibration and reactance information proposed in this paper can diagnose winding loosened state and deformational fault effectively.

VI. CONCLUSIONS

1) Multi-short circuit current impacts experiment are carried out on transformer normal winding, three kinds of deformational fault windings are designed. The vibration and reactance information data sets corresponding to the normal, loosened and deformational fault of transformer windings are obtained, and the diagnosis threshold of winding loosened state is established.

2) Aiming at the winding in latent loosened state, the vibration information of the monitoring model is 0.4268, which is less than the diagnosis threshold of 0.5529. Reactance information change rate is 0.096%, which is less than 2% of the diagnosis standard specified in the IEC 60076-5. The monitoring result is consistent with the conclusion of disassembly inspection experiment.

3) Aiming at three kinds of windings including radial extension in the middle position, axial tension loosened and coil folding in end position, the vibration information of the

monitoring model are 0.2586, 0.1468 and 0.4672 respectively, those are less than the diagnosis threshold of 0.5529. Reactance information change rate are 5.61%, 3.31% and 9.25%, those are all greater than 2% of the diagnosis standard specified in the IEC 60076-5. The monitoring results are consistent with the actual state of three windings.

4) For the winding loosened state which cannot be effectively identified by single resistance information, and for the winding loosened state and deformational faults which cannot be distinguished by single information, the monitoring method based on vibration and reactance information proposed in this paper can diagnose them accurately.

REFERENCES AND FOOTNOTES

- [1] G. B. Kumbhar and S. V. Kulkarni, "Analysis of short-circuit performance of split-winding transformer using coupled field-circuit approach", *IEEE Trans. Power Del.*, vol. 22, no. 2, pp. 936-943, Apr. 2007.
- [2] W.H. Portilla and J.P. Guerra, "Detection of transformer faults using frequency response traces in the low frequency bandwidth", *IEEE Trans. Ind. Electronics*, vol. 61, no. 9, pp. 4971-4978, 2014.
- [3] C. Cao, J.Y. Xu, X. Lin, X.L. Li., "State Diagnosis Method of Transformer Winding Deformation Based on Fusing Vibration and Reactance Parameters", *IET Electric Power Applications*, Vol. 14, no.5, pp. 818-826, 2020.
- [4] Z. Bo and L. Yan, "Research on radial stability of large transformers windings under multiple short-circuit conditions", *IEEE Trans. Appl. Supercond.*, vol. 26, no. 7, pp. 1-4, Oct. 2016.
- [5] S. Pramanik, L. Satish, "Localisation of discrete change in a transformer winding: a network-function-loci approach", *IET Electric Power Applications*, vol. 26, no. 7, 5(6), pp. 540-548, 2011.
- [6] S. H. Wang, H. J. Zhang, S. Wang, H. L. Li and D. S. Yuan, "Cumulative deformation analysis for transformer winding under short-circuit fault using magnetic-structural coupling model", *IEEE Latin Amer. Trans.*, vol. 26, no. 7, pp. 1-5, Oct. 2016.
- [7] H. Rahbarimigham, S. Esmaeili, G. B. Gharehpetian, "Determination of transformer HV winding axial displacement occurrence, direction, and extent using time-domain analysis of UWB signals", *IET Science, Measurement & Technology*, vol. 12, no. 4, pp. 514-520, 2018.
- [8] H. M. Ahn, J. Y. Lee and J. K. Kim, "Finite element analysis of short circuit electromagnetic force in power transformers", *IEEE Trans. Ind. Appl.*, vol. 47, no. 3, pp. 1267-1271, May/June. 2011.
- [9] F. Jawad, M. E. Bashir and N. Tahere, "Three and two-dimensional finite element computation of inrush current and short-circuit electromagnetic forces on windings of a three phase core-type power transformer", *IEEE Trans. Magn.*, vol. 44, no. 5, pp. 590-597, May. 2008.
- [10] Haijun Zhang, B. Yang, W. J. Xu, S. H. Wang, G. L. Wang, Y. P. H. Fu, J. Y. Zhang, "Dynamic deformation analysis of power transformer windings in short-circuit fault by FEM", *IEEE Trans. Appl. Supercond.*, vol. 24, no. 3, pp.1-4, Jun. 2014.
- [11] A. Bakshi and S. V. Kulkarni, "Analysis of buckling strength of inner windings in transformers under radial short-circuit forces", *IEEE Trans. Power Del.*, vol. 29, no. 1, pp. 241-245, Feb. 2014.
- [12] A. Bakshi, "An investigation of winding curvature effect on the mechanical strength of transformer windings", *IEEE Trans. Power Del.*, vol. 30, no. 4, pp. 1821-1826, Aug. 2015.
- [13] E. Rahimpour, C. Jochen and F. Kurt, "Transfer function method to diagnose axial displacement and radial deformation of transformer windings", *IEEE Trans. Power Deliv.*, vol. 18, no. 2, pp. 493-505, Apr. 2003.
- [14] G. Belén, C. B. Juan and M. A. Ángel, "Transformer tank vibration modeling as a method of detecting winding deformations—Part I: Theoretical foundation", *IEEE Trans. Power Deliv.*, vol. 21, no. 1, pp. 157-163, Jan. 2006.
- [15] S. Michael and F. Klaus, "The impacts of inrush currents on the mechanical stress of high voltage power transformer coils", *IEEE Trans. Power Del.*, vol. 17, no. 1, pp. 155-160, Jan. 2002.
- [16] K. Usha, S. Usa, "Inter disc fault location in transformer windings using SFRA", *IEEE Trans. Dielectric. Elect. Insul.*, Vol. 22, no. 6, pp. 3567-3573, 2015.
- [17] J.A.S.B. Jayasinghe, Z.D. Wang, P.N. Jarman and A.W. Darwin, "Winding Movement in Power Transformers: A Comparison of FRA Measurement Connection Methods", *IEEE Trans. Dielectric. Elect. Insul.*, vol. 13, no. 6, pp. 1342-1349, 2006.
- [18] K. Ludwikowski, K. Siodla and W. Ziomek, "Investigation of Transformer Model Winding Deformation Using Sweep Frequency Response Analysis", *IEEE Trans. Dielectr. Elect. Insul.*, vol. 19, no. 6, pp. 1957-1961, 2012.
- [19] J.N. Liu, Z. Y. Zhao, C. Tang, C. G. Yao, C. X. Li, And S. ISLAM, "Classifying Transformer Winding Deformation Fault Types and Degrees Using FRA Based on Support Vector Machine", *IEEE Access*, vol. 7, pp. 112494-112504, 2018.
- [20] A. A. Reykherdt and V. G. Davydov, "Effects of Test Cable Ground Extensions on Repeatability of Frequency Response Analysis Measurements on Power Transformers", *IEEE Electr. Insul. Mag.*, vol. 28, no. 3, pp. 26-31, 2012.
- [21] Z. Huang, Y. H. Chen, S. M. Shi, and L.F. Luo, "Study on Characteristic Parameters of Short-Circuit Impedance for a Four-Winding Inductive Filtering Transformer in Power System Supplying Nonlinear Loads", *IEEE Access*, vol. 7, pp. 115273-115280, 2018.
- [22] M. Bagheri, A. Zollanvari and S. Nezhivenko, "Transformer fault condition prognosis using vibration signals over cloud environment", *IEEE Access*, vol. 6, pp. 9862-9874, 2018.
- [23] K. Hong, L. Wang, S. Xu, "A Variational Mode Decomposition Approach for Degradation Assessment of Power Transformer Windings. *IEEE Transactions on Instrumentation and Measurement*", Vol. 68, no.4, pp. 1221-1229, Apr. 2019.
- [24] J. H. Wang, R. J. Liao, L. Cheng, and Z. D. Cheng, "Effects of Winding Vibration on the Mechanical-Thermal Aging Properties of Insulating Paper", *IEEE Access*, vol. 8, pp. 67912-67920, 2020.
- [25] Y. Q. Liu, S.H. Wang, X.J. Meng, J. Qiu, B. Feng, C.X. Wei and F.H. Liu, "Kinetic characteristics of transformer windings under short circuit condition", *Int. J. Appl. Electromagn. Mech.*, vol. 33, no. 1, pp. 457-464, 2010.
- [26] F. Zhang, S. C. Ji, H. Ma, and T. K. Saha, "Operational Modal Analysis of Transformer Windings", *IEEE Transactions on Power Delivery*, Vol. 35, no.3, pp. 1285-1298, 2020.
- [27] J. Zheng, H. Huang, J. Pan, "Detection of Winding Faults Based on a Characterization of the Nonlinear Dynamics of Transformers", *IEEE Transactions on Instrumentation and Measurement*, Vol. 68, no. 1, pp. 206-214, Jan. 2019.
- [28] J. Seo, H. Ma, and T. K. Saha, "A joint vibration and arcing measurement system for online condition monitoring of on-load tap changer of the power transformer", *IEEE Transactions on Power Delivery*, Vol. 32, no. 2, pp. 1031-1038, 2017.
- [29] M. Zhao, and G. Xu, "Feature extraction of power transformer vibration signals based on empirical wavelet transform and multiscale entropy", *IET Science, Measurement & Technology*, Vol. 12, no. 1, pp. 63-71, 2018.
- [30] P. S. Shin, J. Lee, and J. W. Ha, "A free vibration analysis of helical windings of power transformer by pseudospectral method", *IEEE Transactions on Magnetics*, Vol. 43, no. 6, pp. 2657-2659, 2007.
- [31] IEC 60076-5, "Power transformers – Part 5: Ability to withstand short circuit", International Electrotechnical Commission, Geneva, Switzerland, 2006.



CHEN CAO was born in Liaoning, China, in 1987. He received the Ph.D. degree from Shenyang University of Technology, in 2018. He is currently a Lecturer in School of Electrical Engineering, Shenyang University of Technology. And he works in Key Laboratory of Special Machine and High Voltage Apparatus, Ministry of Education.

His research interest includes fault diagnosis and online monitoring technology of the electrical equipment in the power system.



BOWEN XU was born in Liaoning, China in 1989. He is currently a lecturer (assistant professor) in the Department of Civil Engineering at Xi'an Jiaotong-Liverpool University. He acquired Ph.D. degree in Civil Engineering from the Imperial College London. His research focus on the experimental and numerical study of the comprehensive behaviour of cementitious composites incorporating sustainable components, and dynamic behaviour of constructional materials as well as electric transformers.



XUEBIN LI was born in Liaoning, China. He received the B.S. and M.S. degrees in School of Electrical Engineering from Shenyang University of Technology. He works in State Grid Liaoning Electric Power Supply Co.,LTD.

His research focus on high voltage and electrical equipment technology.