

MONOPOLE-BASED RECTENNA FOR MICROWAVE ENERGY HARVESTING OF UHF RFID SYSTEMS

G. Monti^{*}, F. Congedo, D. De Donno, and L. Tarricone

Department of Engineering for Innovation, University of Salento, Via per Monteroni, Lecce 73100, Italy

Abstract—This paper presents a rectifying antenna (rectenna) for the harvesting of the microwave energy associated to UHF (Ultra-High Frequency) Radio Frequency IDentification (RFID) systems. The proposed device uses a capacitively loaded T-shaped monopole with a coplanar waveguide feeding line as receiving antenna and a five-stage voltage multiplier as rectifier. Experimental results demonstrating an RF-to-DC conversion efficiency of about 54% with an input power density of $80 \mu\text{W}/\text{cm}^2$ will be presented and discussed.

1. INTRODUCTION

The widespread diffusion of services and devices using wireless communications has led to a growing interest in electromagnetic (EM) energy harvesting applications. As a consequence, the development of efficient rectifying antennas (rectennas) has become a hot research topic [1–14]. In fact, a rectenna is a device designed to collect the energy associated to a free propagating EM wave and to transform it into Direct Current (DC) power, thus representing the key element for EM energy harvesting and wireless power transmission applications.

A block scheme of the basic architecture of a rectenna is illustrated in Fig. 1: the Radio Frequency (RF)/microwave EM energy is collected by an antenna (the harvester) and converted into DC power by a rectifying circuit (the rectifier). Due to the small amount of energy usually available at the output port of the rectifier in harvesting applications, the load is represented by a low-power device (such as, for instance, a sensor).

As highlighted in Fig. 1, in order to improve the rectenna RF-to-DC conversion efficiency two blocks can be added respectively between

Received 15 June 2012, Accepted 11 July 2012, Scheduled 15 July 2012

^{*} Corresponding author: Giuseppina Monti (giuseppina.monti@unisalento.it).

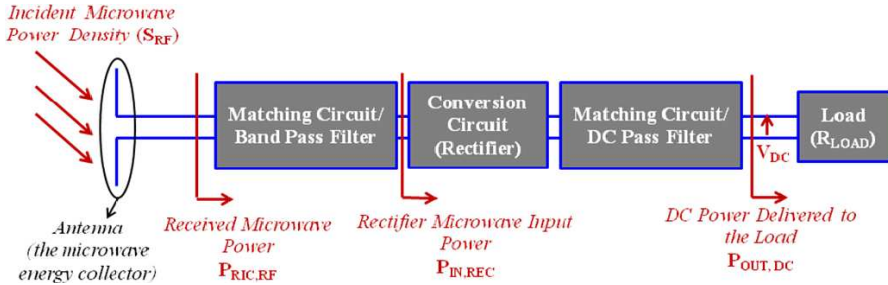

Figure 1. Schematic representation of a rectenna: the microwave energy received by the antenna is converted into a DC signal by the rectifier.

the antenna and the rectifier and between the rectifier and the load. These blocks act both as filtering and as matching sections; they should be optimized in order to simultaneously fulfill the following functions:

- to match the antenna and the load to the rectifier;
- to preserve the antenna from re-irradiating the high order harmonics generated by the rectifier (to this end the block between the antenna and the rectifier should be a pass-band filter);
- to preserve the load from any RF signals (to this end the block between the rectifier and the load should be a DC pass filter).

The rectenna presented in this paper was designed to harvest the EM energy associated to UHF (Ultra-High Frequency) Radio Frequency IDentification (RFID) systems. The target application could be the powering of low-power sensors in industrial environments using UHF RFID systems.

Recently, several rectenna devices have been proposed in the literature [1–14]. In particular, rectennas operating in the UHF-RFID band have been proposed in [8–13].

The solution proposed in [9] uses a loop with a meander design as antenna; a conversion efficiency of 4.7% is obtained with an input power of 1 mW and a resistive load of 5 k Ω . A rectifying circuit for UHF RFID tag is proposed in [10]; a conversion efficiency higher than 30% when the RF input power is 0.1 mW is demonstrated.

In [11] the authors propose a three-band (900 MHz, 1760 MHz, 2450 MHz) rectenna. A conversion efficiency of about 40% is achieved at 900 MHz when the input power is 2.1 mW.

In [12, 13], a rectenna using a bowtie antenna is presented. A conversion efficiency of about 65% with a power density incident on the antenna of 60 $\mu\text{W}/\text{cm}^2$ is experimentally demonstrated.

The rectenna here presented consists of a compact capacitively loaded monopole and a five-stage voltage multiplier. Varactors were used in designing the matching network between the antenna and the rectifier, thus resulting in the possibility of adjusting the rectenna performance as a function of the signal to be harvested. With respect to the solution presented in [12,13], where the antenna and the rectifier must necessarily be on orthogonal planes, the design strategy here proposed allows the positioning of the antenna and of the rectifier on the same plane.

Experimental results, referring to a power density incident on the antenna of $80 \mu\text{W}/\text{cm}^2$, demonstrate an RF-to-DC conversion efficiency higher than 48% over the entire European UHF RFID band (i.e., 865.6–869.6 MHz).

The paper is structured as follows. The architecture of the proposed rectenna is briefly described in Section 2; experimental data of the conversion efficiency are given and discussed in Section 3. Finally, some conclusions are drawn in Section 4.

2. PROPOSED RECTENNA ARCHITECTURE

A photograph of the rectenna presented in this paper is illustrated in Fig. 2. The rectifier is a five stage Cockcroft-Walton voltage

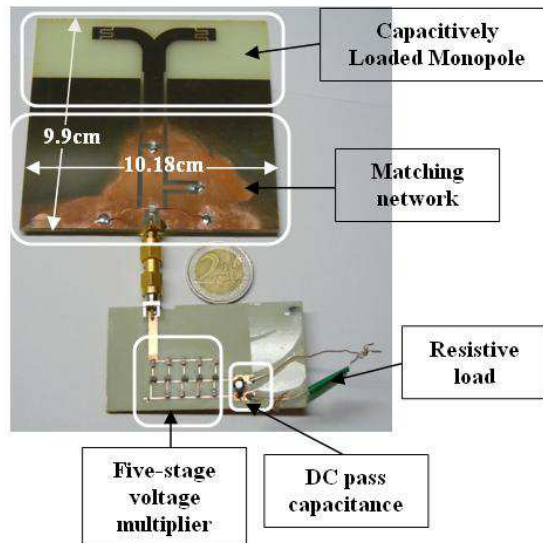

Figure 2. Photograph of the proposed UHF rectenna.

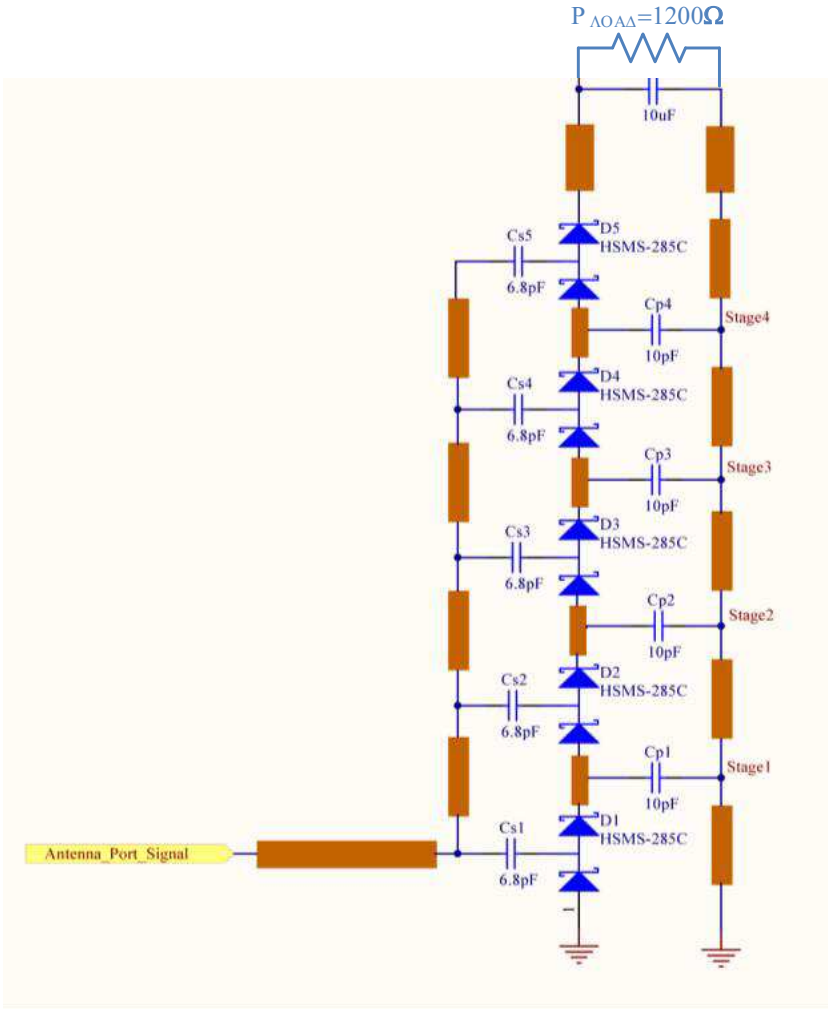

Figure 3. Rectifier equivalent circuit: a five-stage voltage multiplier. A DC pass capacitor was also used to preserve the load from unwanted AC signals and to improve the RF-to-DC conversion efficiency.

multiplier whose circuit schematic is illustrated in Fig. 3. Diodes are the *HSMS-285C* by Avago Technologies [15], while capacitors are 251R15 (0805) *S*-series by Johanson [16]. The presence of a $10\ \mu\text{F}$ DC pass capacitor can be also noticed. A double-sided copper clad FR4 laminate ($\epsilon_r = 3.7$, $\tan(\delta) = 0.019$, $h = 1.6\ \text{mm}$) was used for fabrication.

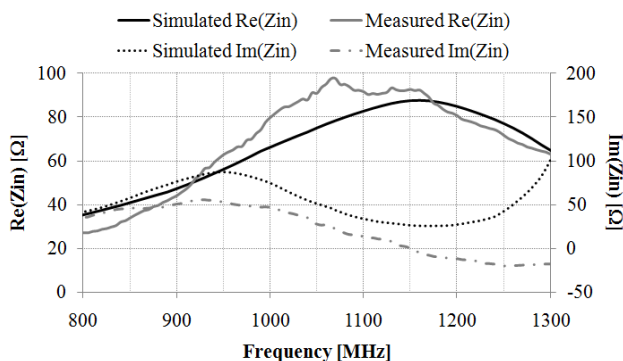

Figure 4. Comparison between circuit simulations and measurements performed for the schematic in Fig. 3 and the realization in Fig. 2, respectively.

By assuming an input power of 10 dBm, capacitors, microstrip lines and the resistive load have been optimized to have a value of about $50\ \Omega$ for the real part of the rectifier input impedance and to maximize the conversion efficiency.

Figure 4 compares experimental data obtained for the realization shown in Fig. 2 and circuital simulation results calculated for the circuit schematic illustrated in Fig. 3. In both cases, an input power of 10 dBm and a resistive load of $1200\ \Omega$ were assumed. Measurements were performed with the ZVL6 vector network analyzer by Rohde&Schwarz, while the Advanced Design System (ADS) software by Agilent Technologies [17] was used for circuital simulations. The mismatch between simulations and measurements is mainly due to parasitic effects associated to the soldering process of capacitors and diodes.

At the central frequency of the European UHF-RFID band (866.6 MHz), the measured value of the rectifier input impedance was approximately $(40 + j40)\ \Omega$. This value was used during the design process of the antenna and of the matching network.

More specifically, the starting geometry of the antenna was a T-shaped monopole with a coplanar waveguide feeding line (see Fig. 5) on a single-sided copper clad FR4 laminate ($\epsilon_r=3.7$, $\tan(\delta) = 0.019$, $h = 1.6\ \text{mm}$). In order to simplify the process of customization of the antenna input impedance and to reduce its dimensions, both arms of the monopole were loaded with an interdigitated capacitor (see Fig. 5).

We firstly optimized the antenna dimensions to have a resonance frequency at 866.6 MHz and an input impedance of $50\ \Omega$. Optimizations were performed by means of the full-wave simulator

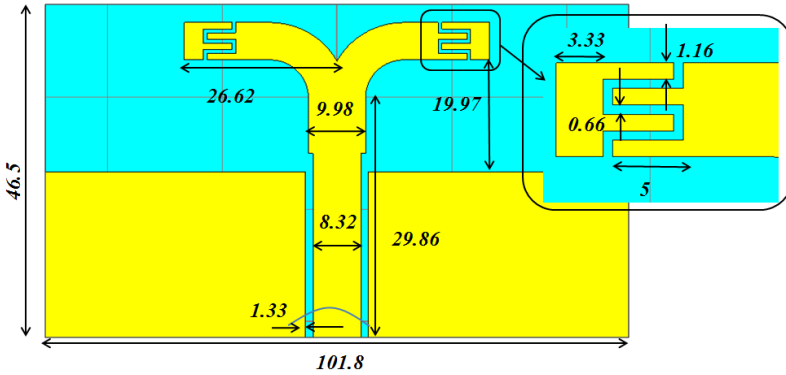

Figure 5. Layout of the capacitively loaded T-shaped monopole. All dimensions are in millimeters.

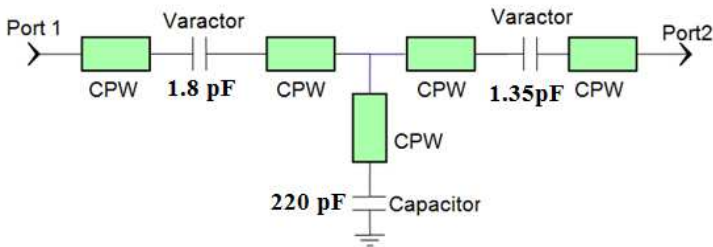

Figure 6. Equivalent circuit of the network used to match the monopole antenna to the rectifier. In order to have during experimental tests the possibility of improving the level of matching between the antenna and the rectifier, varactors were used instead of fixed capacitors.

CST Microwave Studio [18]. The antenna input impedance calculated this way was used in circuit simulations to design a network for matching the monopole antenna to the rectifier. To this regard, the rectifier was modeled as a black-box component described by measurements performed for an input power of 10 dBm. Fig. 6 illustrates the schematic of the matching network designed with ADS. Finally, full-wave optimizations were performed for the overall layout corresponding to the antenna integrated with the matching network (see Fig. 7).

Dimensions calculated this way are given in Figs. 5 and 7. The antenna and the matching network occupy a total area of $(99.6 \times$

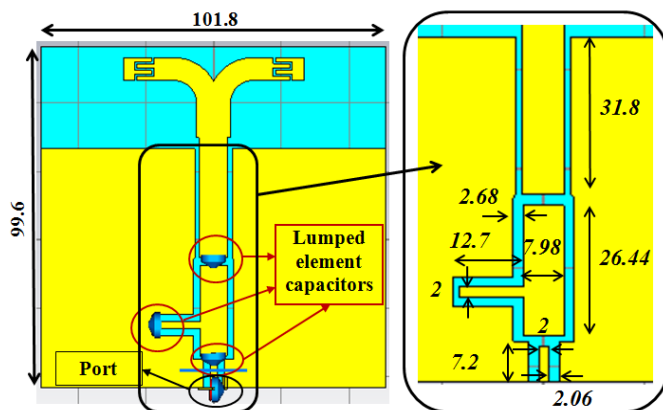

Figure 7. Layout of the antenna integrated with the matching network. All dimensions are in millimeters.

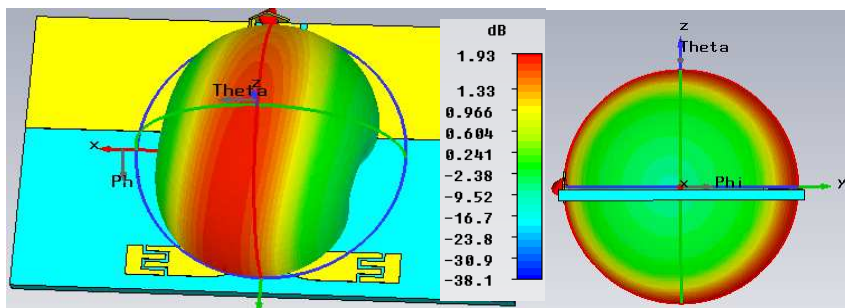

Figure 8. Three-dimensional radiation pattern of the antenna illustrated in Fig. 7. Results obtained at 866.6 MHz by means of full-wave simulations.

101.8) mm²; with reference to the wavelength calculated at 866.6 MHz, these dimensions approximately correspond to $(0.28 \times 0.29)\lambda^2$. Figs. 8 and 9 show the antenna gain calculated by means of full wave simulations. It can be noticed that at 866.6 MHz the antenna exhibits a dipole-like radiation pattern with 2 dB maximum gain. The simulated gain values have been used to calculate the effective area of the proposed antenna according to the following formula:

$$A_{eff} = \left(\frac{\lambda_0^2 G}{4\pi} \right) \tag{1}$$

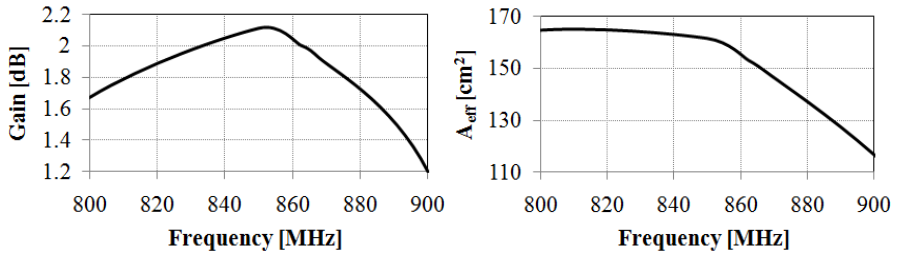

Figure 9. Antenna gain and effective area calculated by means of full-wave simulations along the z -axis direction.

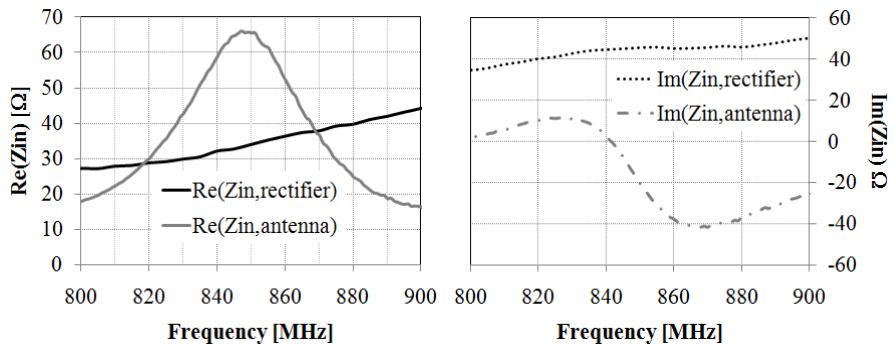

Figure 10. Comparison between experimental data of the input impedance of the layout in Fig. 7 (i.e., antenna and matching network) and the one of the rectifier.

Corresponding results are reported in Fig. 9.

As for the realization of the prototype illustrated in Fig. 2, varactors from Murata Electronics [19] (TZY2Z2R5A001R00) with a capacitance range of 0.65–2.5 pF were used as series capacitors in the matching network (see Figs. 6 and 7). Such variable capacitors were exploited during experimental tests to adjust the input impedance of the layout illustrated in Fig. 7 so to satisfy the conjugate match condition with respect to the input impedance of the rectifier. Results obtained this way are shown in Fig. 10, where the measured input impedance of the layout in Fig. 7 is compared with the one obtained for the rectifier by using an input power of 10 dBm. It can be seen that, in the frequency range of interest, the conjugate matching is satisfied with a good approximation. In fact, at 866.6 MHz the measured input impedance of the rectifier and the one of the layout shown in Fig. 7 were approximately equal to $(40 + j40) \Omega$ and to $(42 - j41) \Omega$, respectively.



Figure 11. The software-defined radio (SDR) platform used in the experimental tests of the RF-to-DC conversion efficiency.

3. EXPERIMENTAL RESULTS ON CONVERSION EFFICIENCY

The Software-Defined Radio (SDR) platform in Fig. 11 was used for experimental tests of the RF-to-DC conversion efficiency. The signal incident on the rectenna was generated by means of the GNUradio toolkit [20] and the Universal Software Radio Peripheral (USRP) equipped with the RFX-900 daughterboard [21].

Measurements were performed in a large outdoor area, thus guaranteeing that spurious reflections were not present. In all measurements, the distance between the rectenna and the USRP transmitting dipole was 70 cm.

Furthermore, loss due to polarization mismatches was minimized by adjusting the relative position of the transmitting and receiving antenna. To this regard, it is worth underlining that the proposed rectenna has an almost x -directed linear polarization.

Experiments were performed for different values of the resistive load and power density of the microwave signal incident on the antenna. The following definition has been used to calculate the RF-to-DC conversion efficiency (η):

$$\eta = \frac{P_{\text{OUT,DC}}}{S_{\text{RF}}A_G} = \left(\frac{V_{\text{DC}}^2}{R_{\text{LOAD}}} \right) \frac{1}{S_{\text{RF}}A_G} \quad (2)$$

where S_{RF} is the power density incident on the antenna, V_{DC} is the DC output voltage (see Fig. 1), R_{LOAD} is the resistive load. A_G is the geometric area of the antenna, which is approximately equal to $(10.18 \times 4.65) \text{ cm}^2$.

The PMM 8053A broadband field meter with the EP-183 isotropic probe was used to measure S_{RF} . Results obtained this way are given in Figs. 12 and 13.

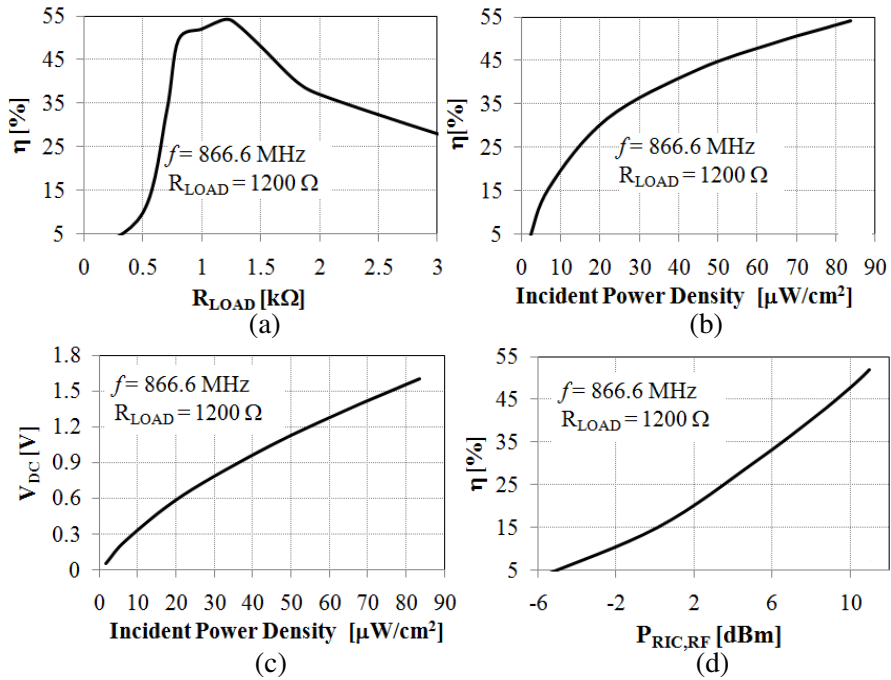

Figure 12. Experimental data obtained at 866.6 MHz for the conversion efficiency of the proposed rectenna. (a), (b) Conversion efficiency as function of the resistive load and of the power density incident on the antenna, (c) output voltage as function of the incident power density, (d) conversion efficiency as function of the power received by the antenna.

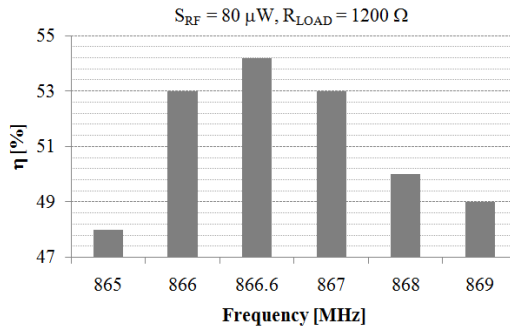

Figure 13. Measurements of the proposed rectenna conversion efficiency as a function of the incident signal frequency.

In order to verify the performance of the proposed rectenna when used for the scavenging of RF power associated with UHF RFID systems, measurements of η were performed by setting the frequency of the microwave signal generated by the USRP to 866.6 MHz (i.e., the center frequency of the European UHF-RFID band) Results are shown in Fig 12.

A first set of experiments was performed by setting the power transmitted by the USRP to its maximum value and by varying the resistive load of the rectifier (R_{LOAD}) (see Fig. 12(a)). Experimental data confirmed that the best value of R_{LOAD} is the same calculated by circuit and full-wave simulations (i.e., 1200 Ω). A second set of experiments was performed by keeping a constant value of 1200 Ω as resistive load and by varying the power transmitted by the USRP (and therefore the value of S_{RF}). Achieved results are reported in Figs. 12(b) and 12(d). In correspondence of the maximum value obtained for S_{RF} (83.7 $\mu\text{W}/\text{cm}^2$), a maximum of 54.2% was calculated for η (see Fig. 12(b)) The voltage values measured at the output port of the rectifier that have been used in calculating η are given in Fig. 12(c). It can be noticed that the maximum value of η corresponds to an output voltage of about 1.6 V. The conversion efficiency of the proposed rectenna as a function of the received power ($P_{RIC,RF}$) is illustrated in Fig. 12(d). $P_{RIC,RF}$ has been calculated by using the value calculated at 866.6 MHz for the effective area of the antenna:

$$P_{RIC,RF} = A_{eff} S_{RF} \quad (3)$$

It is worth noticing that the maximum value of S_{RF} obtained with our experimental setup corresponds to a value of $P_{RIC,RF}$ (i.e., the power at the input port of the rectifier) approximately equal to the one for which the performance of the proposed rectenna was optimized (10 dBm).

Finally, experiments were also performed by varying the frequency of the microwave signal incident on the antenna while maintaining constant its power density at approximately 80 $\mu\text{W}/\text{cm}^2$. Experimental results collected in the European UHF RFID band (865.6–869.6 MHz) are illustrated in Fig. 13. As shown, the proposed rectenna exhibits an RF-to-DC conversion efficiency higher than 48% over the entire band of interest.

4. CONCLUSION

A rectenna for the harvesting of electromagnetic energy associated to the European RFID band has been presented. The proposed device consists of a compact T-shaped monopole and a five-stage voltage multiplier with RF-Schottky diodes. Experimental data

have been reported and discussed, demonstrating that the proposed rectenna exhibits an RF-to-DC conversion efficiency higher than 48% over the entire European UHF RFID band. More specifically, from measurements performed with a power density incident on the monopole of about $83 \mu\text{W}/\text{cm}^2$, a conversion efficiency of about 54% has been achieved at 866.6 MHz. These results confirm the suitability of the rectenna here presented for powering sensors and other low-power devices by scavenging the electromagnetic energy associated to UHF RFID systems.

REFERENCES

1. Takhedmit, H., et al., "A 2.45-GHz low cost and efficient rectenna," *Proc. of the 4th EuCAP*, Barcelona, Spain, Apr. 2010.
2. Monti, G., L. Tarricone, and M. Spartano, "X-band planar rectenna," *Antenn. and Wirel. Propag. Lett.*, Vol. 10, 1116–1119, 2011.
3. Heikkinen, J. and M. Kivikoski, "Low-profile circularly polarized rectifying antenna for wireless power transmission at 5.8 GHz," *IEEE Microw. and Wirel. Compon. Lett.*, Vol. 14, No. 4, Apr. 2004.
4. Monti, G., L. Tarricone, and M. Spartano, "X-band planar rectenna," *Antenn. and Wirel. Propag. Lett.*, Vol. 10, 1116–1119, 2011.
5. Ali, M., G. Yang, and R. Dougal, "A new circularly polarized rectenna for wireless power transmission and data communication," *IEEE Antenn. Wirel. Propag. Lett.*, Vol. 4, 205–208, 2005.
6. Heikkinen, J. and M. Kivikoski, "A novel dual-frequency circularly polarized rectenna," *IEEE Antenn. Wirel. Propag. Lett.*, Vol. 2, 330–333, 2003.
7. Strassner, B. and K. Chang, "Highly efficient C-band circularly polarized rectifying antenna array for wireless microwave power transmission," *IEEE Trans. on Antenn. Propag.*, Vol. 51, No. 6, 1347–1356, Jun. 2003.
8. Tikhov, Y., I.-J. Song, and Y.-H. Min, "Rectenna design for passive RFID transponders," *Proc. of the 37th EUMC*, Munich, Germany, Oct. 2007.
9. Chen, R. H., Y. C. Lee, and J. S. Sun, "Design and experiment of a rectifying antenna for 900 MHz wireless power transmission," *PIERS Proceedings*, Beijing, China, Mar. 2009.
10. Seeman, K. and R. Weigel, "Ultra low power rectification in

- passive RFID tags at UHF frequencies,” *Frequenz*, No. 59, 112–115, 2005.
11. Rizzoli, V., G. Bichicchi, A. Costanzo, F. Donzelli, and D. Masotti, “CAD of multi-resonator rectenna for micro-power generation,” *Proc. of the 4th EuMIC*, Rome, Italy, Sep. 2009.
 12. Congedo, F., G. Monti, and L. Tarricone, “Broadband bowtie antenna for RF energy scavenging applications,” *Proc. of 4th EuCAP*, 11–15, Rome, Apr. 2011.
 13. Monti, G. and F. Congedo, “UHF rectenna using a bowtie antenna,” *Progress In Electromagnetic Research C*, Vol. 26, 181–192, 2012.
 14. Riviere, S., F. Alicalapa, A. Douyere, and J.-D. Lan Sun Luk, “A compact rectenna device at low power level,” *Progress In Electromagnetic Research C*, Vol. 16, 137–146, 2010.
 15. Avago technologies, HSMS-285x Series Surface Mount Zero Bias Schottky Detector Diodes data sheet, retrieved in June 2012, from www.avagotech.com/pages/home/.
 16. Johanson technology, R15S (0805) S-Series, Low ESR Capacitor Multi-Layer High-Q data sheet, retrieved in June 2012, from www.johansontechnology.com/.
 17. Agilent, Advanced Design System brochure, retrieved in June 2012, from www.agilent.com/find/eesof-ads.
 18. Computer Simulation Technology, www.cst.com/ [visited on June 30, 2012].
 19. Murata Europe, www.murata.eu/.
 20. gnuradio.org/ [visited on June 30, 2012].
 21. Ettus Research LLC, RFX-900 daughterboard product details, retrieved in June 2012, from <http://www.ettus.com>.