



12-1987

# Monopoly Power and Market Power in Antitrust Law

Thomas G. Krattenmaker

*Former Dean, William & Mary Law School*

Robert H. Lande

*University of Baltimore School of Law, rlande@ubalt.edu*

Steven C. Salop

*Georgetown Law, salop@law.georgetown.edu*

Follow this and additional works at: [http://scholarworks.law.ubalt.edu/all\\_fac](http://scholarworks.law.ubalt.edu/all_fac)

 Part of the [Antitrust and Trade Regulation Commons](#), and the [Law and Economics Commons](#)

## Recommended Citation

Monopoly Power and Market Power in Antitrust Law, 27 J. Reprints Antitrust L. & Econ. 585 (1997)

This Article is brought to you for free and open access by the Faculty Scholarship at ScholarWorks@University of Baltimore School of Law. It has been accepted for inclusion in All Faculty Scholarship by an authorized administrator of ScholarWorks@University of Baltimore School of Law. For more information, please contact [snolan@ubalt.edu](mailto:snolan@ubalt.edu).

# Monopoly Power and Market Power in Antitrust Law

THOMAS G. KRATTENMAKER\*

ROBERT H. LANDE\*\*

STEVEN C. SALOP\*\*\*

## INTRODUCTION

This article seeks an answer to a question that should be well settled: for purposes of antitrust analysis, what is “market power” or “monopoly power”? The question should be well settled because antitrust law now requires proof of actual or likely market power or monopoly power to establish most types of antitrust violations. These legal rules follow prevailing antitrust policy analysis, which suggests that concepts of market power or monopoly power should play a crucial role in defining the reach of most antitrust proscriptions.

Examination of key antitrust law opinions, however, shows that courts define “market power” and “monopoly power” in ways that are both vague and inconsistent. We conclude that the present level of confusion is unnecessary and results from two different but related errors: (1) the belief or suspicion that market power and monopoly power are two different concepts, when they are in fact, for antitrust purposes, qualitatively identical, and (2) the failure to recognize that anticompetitive economic power may manifest itself in two distinct ways. We argue that attempting to distinguish between market power and monopoly power creates a false dichotomy. Real differences, with significant legal and policy implications, do exist, however, between anticompetitive economic power that is exercised by restricting one’s own output and such power exercised by restricting the output of one’s rivals. Identifying this fundamental distinction and discarding the false one can help to clarify other troublesome antitrust issues as well.

The body of this article describes these conclusions, and the bases for them, in some detail. The appendix presents a shorter, more technical description of the principal argument. Readers already familiar with the main

---

\* Professor of Law, Georgetown University Law Center.

\*\* Assistant Professor of Law, University of Baltimore School of Law.

\*\*\* Professor of Economics and Law, Georgetown University Law Center.

This article refines and extends some of the analyses by the same authors in “Revitalizing Section 2,” a paper presented at the Airlie House Conference on Antitrust Alternatives. For helpful comments on this article and the earlier paper, we are grateful to Jon Baker, Joe Brodley, Ronald Cass, Victor Kramer, Howard Marvel, Peter Menell, Wendy Perdue, Robert Pitofsky, Joe Simons, Joe Sims, Tom Sullivan, and Donald Turner. Ilyse Schuman provided very valuable research assistance.

body of antitrust law and conversant with antitrust economics may wish to begin by reading the appendix.

## I. THE RELEVANCE OF MONOPOLY POWER AND MARKET POWER TO ANTITRUST ANALYSIS

### A. FORMAL LEGAL STANDARDS

Most antitrust rules require the plaintiff to show that the defendant has or is likely to obtain "market power" or "monopoly power." The offense of monopolization requires, of course, proof that the defendant has monopoly power.<sup>1</sup> An illegal attempt to monopolize occurs, according to the majority view, only when there is a dangerous probability that the defendant will succeed in obtaining a monopoly.<sup>2</sup> The Department of Justice measures the antitrust legality of corporate mergers against a set of guidelines whose "unifying theme" is said to be "that mergers should not be permitted to create or enhance 'market power' or to facilitate its exercise."<sup>3</sup> The first step in determining the antitrust legality of joint ventures for research and development or for production is to ask whether the partners, if merged, would achieve market power.<sup>4</sup> According to the Supreme Court's latest formulation, a tying arrangement is not illegal unless the seller has "market power" in the tying product.<sup>5</sup> Virtually any summary of the relevant factors in a case to be judged under the "rule of reason" will include the presence or absence of "market power" as a key factor.<sup>6</sup>

Certain antitrust violations, conventionally described as "per se" offenses, do not require proof of market or monopoly power.<sup>7</sup> Indeed, the label "per se" seems to point to the irrelevance of market power. An essential characteristic of a "per se" offense, however, seems to be that it constitutes behavior that, if engaged in by a firm with market power, would be egregiously anticompetitive.<sup>8</sup> Market power is treated as irrelevant only because "per se" offenses involve behavior that courts have determined virtually always lacks plausible efficiency justifications; no harm is done, therefore, by condemning the practice without undergoing the expense of an inquiry into monopoly or market power.<sup>9</sup>

---

1. *United States v. Grinnell Corp.*, 384 U.S. 563, 570 (1966).

2. P. AREEDA & D. TURNER, *ANTITRUST LAW* ¶ 820 (1978).

3. U.S. Dep't of Justice Merger Guidelines, 49 Fed. Reg. 26,823 (1984).

4. T. BRUNNER, T. KRATTENMAKER, R. SKITOL & A. WEBSTER, *MERGERS IN THE NEW ANTITRUST ERA 69-72* (1985). Of course, joint ventures may contain agreements that constitute per se violations of the Sherman Act.

5. *Jefferson Parish Hosp. Dist. No. 2 v. Hyde*, 466 U.S. 2, 16-17 (1984).

6. *Ball Memorial Hosp. v. Mutual Hosp. Ins.*, 784 F.2d 1325, 1334-35 (7th Cir. 1986).

7. *ANTITRUST LAW DEVELOPMENTS (SECOND)* § 22 (ABA 1984).

8. *White Motor Co. v. United States*, 372 U.S. 253, 263 (1963).

9. *Northwest Wholesale Stationers v. Pacific Stationery & Printing Co.*, 472 U.S. 284, 294

corporation's headquarters from a small town to a big city;<sup>16</sup> because it is part of a trend toward lessening the number of single-store groceries;<sup>17</sup> because it may eliminate a potential market entrant to whom no firm in the market pays any attention;<sup>18</sup> and because it may eliminate competition among firms that may or may not compete in a relevant market.<sup>19</sup> Conversely, certain agreements among competitors to restrict their outputs have been held permissible because they permitted a dying industry to keep up its profits until rigor mortis set in;<sup>20</sup> because they enabled firms to shorten their work days;<sup>21</sup> and because they assisted firms who wished not to compete to achieve that goal.<sup>22</sup>

These opinions cannot all be correct. If antitrust law is required to maximize simultaneously the welfare of small communities, the number of Mom-and-Pop stores, the absolute freedom of entry, all interfirm competition, the wealth of creditors of firms nearing bankruptcy, workers' leisure time, and the ability of firms to avoid competing with each other, then antitrust law is paralyzed. Most business behavior will advance at least one of these interests while retarding at least one other.

Today, a consensus is emerging that the solution to this dilemma is not to call on antitrust enforcers and judges to balance, in some unstated fashion, every social, political, or economic interest or value affected by a business decision. Rather, antitrust should be viewed as "a consumer welfare prescription."<sup>23</sup> Under this interpretation, a practice restrains trade, monopolizes, is unfair, or tends to lessen competition if it harms consumers by reducing the value or welfare they would have obtained from the marketplace absent the practice.<sup>24</sup>

Deciding to interpret the antitrust laws to fashion rules designed to protect

16. *United States v. Falstaff Brewing Corp.*, 410 U.S. 526, 541-42 (1973) (Douglas, J., concurring).

17. *United States v. Von's Grocery Co.*, 384 U.S. 270, 278 (1966).

18. *Falstaff*, 410 U.S. at 537.

19. *United States v. Pabst Brewing Co.*, 384 U.S. 546, 549 (1966).

20. *National Assoc. of Window Glass Mfrs. v. United States*, 263 U.S. 403, 412 (1923).

21. *Chicago Bd. of Trade v. United States*, 246 U.S. 231, 241 (1918).

22. *Appalachian Coals v. United States*, 288 U.S. 344, 376-77 (1933).

23. R. BORK, *THE ANTITRUST PARADOX* 66 (1978); see R. POSNER, *ANTITRUST LAW: AN ECONOMIC PERSPECTIVE* 18 (1976) (one political argument is that monopoly power transfers wealth from consumers to stockholders of monopolistic firms). This is not to deny that social or political values have a role to play in setting antitrust rules. For example, Lande has argued that the legislative history of the Sherman Act shows that Congress intended the antitrust laws to protect small business to the extent that this could be accomplished without harming consumers. Lande, *supra* note 11, at 101-05, 120-21, 139-40; see Pitofsky, *The Political Content of Antitrust*, 127 U. PA. L. REV. 1051 (1979) (discussing political values involved in antitrust).

24. This appears to be the rationale underlying such Supreme Court opinions as *Continental T.V., Inc. v. GTE Sylvania Inc.*, 433 U.S. 36 (1977); *Broadcast Music Inc. v. CBS*, 441 U.S. 1 (1979); *Copperweld Corp. v. Independence Tube Corp.*, 467 U.S. 752 (1984); *NCAA v. Board of Regents*, 468 U.S. 85 (1984); and *Northwest Wholesale Stationers v. Pacific Stationery & Printing*

Market power or monopoly power, then, is a crucial and central issue in almost any complex antitrust case today. Even for the theoretically simpler cases involving claims of "per se" violations, the concepts of market and monopoly power lurk in the shadows because these concepts are relevant to the threshold question of whether the type of behavior at issue is properly characterized as "per se" illegal.<sup>10</sup>

## B. POLICY ANALYSIS

The widespread and increasing emphasis on the role of market power in antitrust rules fits well with the current dominant strains of antitrust policy analysis. Indeed, antitrust law's increasing absorption of market power standards is due in some measure to the influence of these analytical theories.

Confusion exists over the theoretical bases of antitrust law, confusion which stems directly from the fact that no one can tell from the plain language of the predominant antitrust statutes<sup>11</sup> what interests they are designed to protect. Section one of the Sherman Act forbids "restraint of trade";<sup>12</sup> section two makes it unlawful to "monopolize" or "attempt to monopolize;"<sup>13</sup> the Federal Trade Commission Act forbids "unfair methods of competition;"<sup>14</sup> and the Clayton Act condemns tying arrangements, exclusive dealing contracts, and mergers that may "substantially lessen competition or tend to create a monopoly."<sup>15</sup> None of these phrases has any fixed meaning. Indeed, it is questionable whether a more ambiguous antitrust statute could be devised.

Because the statutes do not explicitly tell judges whose interests to protect, judges feel free to choose their own favorite candidates. Consequently, Supreme Court Justices have expressed the opinions, in various cases, that a corporate merger might be held illegal because it would lead to removing a

(1985). Another reason for per se rules is to provide clear signals to business and to increase judicial economy.

10. Indeed, the Supreme Court made this link explicitly in the *Hyde* case when it held that tie-ins are per se illegal, but only if the seller has market power in the tying product. *Jefferson Parish Hosp. Dist. No. 2 v. Hyde*, 466 U.S. 2, 16-17 (1984).

11. The statutes are collected as appendix A to M. HANDLER, H. BLAKE, R. PITOFKY & H. GOLDSCHMID, *TRADE REGULATION* (2d ed. 1983). When we refer in this article to "antitrust law," we have in mind the case law flowing from these statutes. Despite the different language in the various antitrust statutes, there is no indication that Congress intended to require different types of economic power under the different statutes. See Lande, *Wealth Transfers as the Original and Primary Concern of Antitrust: The Efficiency Interpretation Challenged*, 34 HASTINGS L.J. 65 (1982) (discussing goals of various antitrust statutes).

12. 15 U.S.C. § 1 (1982).

13. 15 U.S.C. § 2 (1982).

14. 15 U.S.C. § 45 (1982).

15. 15 U.S.C. §§ 12-27 (1982).

consumer welfare, however, does not make antitrust analysis uncomplicated or as readily predictable as the late-season demise of the Boston Red Sox. For example, the precise meaning of "consumer welfare" is debatable.<sup>25</sup> Further, antitrust analysis often requires predicting what may happen in the future as a result of recent or proposed behavior.<sup>26</sup> Predicting the effects of behavior on future consumer welfare is no easier than, say, predicting its effects on the number of Mom-and-Pop grocery stores.<sup>27</sup>

Whatever the merits of this view, treating consumer welfare as the key interest in antitrust law brings market power to center stage. Consumer welfare is reduced most obviously when market prices exceed competitive levels. When economists use the terms "market power" or "monopoly power," they usually mean the ability to price at a supracompetitive level.<sup>28</sup> The view of consumer welfare as the central policy goal of antitrust therefore suggests that the law of antitrust is correct as it increasingly focuses on market power.

## II. JUDICIAL DEFINITIONS OF MARKET POWER AND MONOPOLY POWER

Today, courts appear to be confused about whether market power and monopoly power are similar or distinct concepts. Furthermore, because the definitions that have evolved for market power and monopoly power may be incompatible, courts may face the difficult task of determining which stan-

Co., 472 U.S. 284 (1985). See Lande, *supra* note 11, at 67 n.2 (emphasizing judicial uncertainty of goals of antitrust laws).

25. See Krattenmaker & Salop, *Anticompetitive Exclusion: Raising Rivals' Costs to Achieve Power over Price*, 96 YALE L.J. 209, 279-81 (1986) (highlighting complexities in defining consumer welfare); H. HOVENKAMP, *ECONOMICS AND FEDERAL ANTITRUST LAW* 45-49 (1985) (notion of consumer welfare is ambiguous, but often used to mean optimal allocative efficiency).

Some believe that the congressional concern for "consumer welfare" amounts to nothing more than a desire to enhance economic efficiency. Those analysts believe that the only cognizable harm from market power is allocative inefficiency. See generally R. BORK, *supra* note 23, at 72-89. Others argue that the "consumer welfare" Congress intended to protect is a broader concept. They believe that Congress disapproved of market power principally because it "unfairly" extracts wealth from consumers. See generally Lande, *supra* note 11, at 65 (discussing goals of antitrust law).

26. For example, those with a pure economic efficiency orientation would first determine whether a challenged practice would cause supracompetitive pricing. If so, they would balance the resulting allocative inefficiency against any accompanying production efficiency gains. See generally Muris, *The Efficiency Defense Under Section 7 of the Clayton Act*, 30 CASE W. RES. L. REV. 381 (1980) (explicating theory in detail). Those with a consumer perspective also would start by asking whether the practice could result in market power. If so, they would condemn the practice unless it also generated production efficiencies large enough to prevent prices from rising. See Fisher & Lande, *Efficiency Considerations in Merger Enforcement*, 71 CALIF. L. REV. 1580 (1983) (discussing efficiencies); Fisher, Lande & Vandaele, *Afterword: Could a Merger Lead to Both a Monopoly and Lower Price?*, 71 CALIF. L. REV. 1697 (1983) (same).

27. See Krattenmaker & Salop, *supra* note 25, at 253-66 (measuring likelihood and magnitude of anticompetitive effects); Fisher & Lande, *supra* note 26 (discussing elements involved in prediction).

28. See F.M. SCHERER, *INDUSTRIAL MARKET STRUCTURE AND ECONOMIC PERFORMANCE* 14-16 (2d ed. 1980) (discussing economic meaning of market power and monopoly power).

dard is more appropriate for the various types of antitrust violations.<sup>29</sup> We believe that market power and monopoly power are qualitatively identical concepts—both terms refer to anticompetitive economic power that ultimately can compromise consumer welfare. Courts should be less concerned with labeling the type of anticompetitive economic power exerted by a firm; rather, they should focus on the methods by which this power is achieved.

Supreme Court opinions demonstrate a marked inconsistency as to whether market power and monopoly power are similar or distinct concepts. We can find no Supreme Court opinion that contrasts the terms “market power” and “monopoly power” deliberately and explicitly, i.e., that finds the existence of one but not the other. Recently, in *Matsushita Electric Industrial Co. v. Zenith Radio Corp.*,<sup>30</sup> Justice Powell’s majority opinion appeared to use both terms to mean the power to price profitably above cost.<sup>31</sup> Other Supreme Court opinions also appear to treat market power and monopoly power as identical concepts.<sup>32</sup>

Despite these references, however, the Supreme Court, in other cases, seems to have articulated standards for “monopoly power” and “market power” that, at least linguistically, are incompatible. In *NCAA v. Board of Regents*,<sup>33</sup> the Court defined “market power” as “the ability to raise prices above those that would be charged in a competitive market.”<sup>34</sup> By contrast,

---

29. In some cases, the terms of the authority defining the antitrust violation will specify whether “market power” or “monopoly power” should be used to label the anticompetitive economic power at issue. For example, § 2 of the Sherman Act makes it unlawful to “monopolize” or “attempt to monopolize.” In a case brought under § 2, therefore, the “monopoly power” standard would be applicable. If “market power” and “monopoly power” are qualitatively identical, the label used to describe the conduct in question should make little practical difference. Of course, even under our unified approach, courts would have to identify quantitatively lower degrees or probabilities of market power to interdict a merger under § 7 of the Clayton Act than to proscribe a monopoly under § 2 of the Sherman Act.

If, on the other hand, “market power” and “monopoly power” are fundamentally different, courts may be required to determine which standard is appropriate in cases where the authority defining the antitrust violation prohibits only something as ambiguous as a “restraint of trade” or an “unfair method of competition.”

30. 475 U.S. 574 (1986).

31. *Id.* at 1358.

32. See *Hanover Shoe v. United Shoe Mach. Corp.*, 392 U.S. 481, 486 n.3 (1968) (market power); *id.* at 486 (monopoly power); *United States v. Grinnell Corp.*, 384 U.S. 563, 580 (1966) (market power); *id.* at 577 (monopoly power).

In *Fortner Enterprises v. United States Steel Corp.*, 394 U.S. 495 (1969), Justice White’s dissenting opinion appears to define “market power” as a lesser degree of economic power than “monopoly power.” *Id.* at 510 (White, J., dissenting, joined by Harlan, J.). Perhaps for reasons such as this, Posner at one time described market power as a “debased” form of monopoly power. R. POSNER, *supra* note 23, at 102.

33. 468 U.S. 85 (1984).

34. *Id.* at 109 n.38. This is the Court’s most recent definition of market power. Although the Court in *NCAA* articulated a definition of “market power” that was linguistically different from the definition of “monopoly power” articulated in *du Pont*, the *NCAA* Court nonetheless cited *du Pont*

the Supreme Court has consistently defined "monopoly power," at least for section two cases, in accordance with the definition articulated in *United States v. E.I. du Pont de Nemours & Co.*<sup>35</sup>—i.e., as "the power to control prices or exclude competition."<sup>36</sup> Strictly construed, the Court's language appears to require a higher burden of proof to establish "market power" than to demonstrate "monopoly power," because proof of a defendant's ability to exclude competition would not suffice to demonstrate the existence of "market power." Moreover, even the price portion of the *du Pont* monopoly power definition is broader than the *NCAA* market power standard because the latter ignores the ability to prevent price decreases.

Economists use both "market power" and "monopoly power" to refer to the power of a single firm or group of firms to price profitably above marginal cost.<sup>37</sup> Less technically, the terms both refer to the ability to price above competitive levels.<sup>38</sup> Of course, this anticompetitive economic power can exist in varying degrees. One firm may be able to price well above competitive levels consistently and profitably while another may be able only to price slightly above the competitive norm for a short time. But the type of power described is qualitatively identical in both cases.

We believe that antitrust law should dispense with the idea that market power and monopoly power are different concepts. Rather, courts should focus on distinguishing clearly between two alternative and independent methods of achieving anticompetitive economic power.<sup>39</sup> These two alterna-

for the definition of both terms (*id.* at 109 n.38 ("market power"); *id.* at 112 ("monopoly power")). The only term used in *du Pont*, however, is "monopoly power."

35. 351 U.S. 377 (1956) (decision is sometimes referred to as the *Cellophane* case). For a critique of *du Pont*, see Turner, *Antitrust Policy and the Cellophane Case*, 70 HARV. L. REV. 281 (1956). See *infra* note 75 and accompanying text (explicating "Cellophane fallacy").

36. *Id.* at 391. The Court reiterated the *du Pont* formulation in *United States v. Grinnell Corp.*, 384 U.S. 563, 571 (1966), and in *Aspen Skiing Co. v. Aspen Highlands Skiing Corp.*, 472 U.S. 585, 596 n.20 (1985).

37. The concept of marginal cost is easy to state. In practice, however, marginal cost sometimes is controversial to define and difficult to measure. These complications are beyond the scope of this article.

38. In a perfectly competitive market, firms take the market price as given. That is, as price-takers they ignore any effects of their production decisions on the market price. In such a market, each firm maximizes its profits by expanding its output until its marginal cost (i.e., its cost of producing an additional unit) equals the market price (i.e., the firm's perceptions of the additional revenue the unit of output will create). In a perfectly competitive market, all firms have the same marginal cost at the levels of output they produce. More efficient firms (i.e., those with lower marginal costs for particular levels of output) produce more output. They earn higher profits because they have lower average costs, although their marginal costs at the level of output they produce is the same as their less efficient competitors.

39. Other precepts of antitrust law demonstrate the appropriateness of focusing antitrust analysis on the method by which anticompetitive economic power is achieved. For example, the existence of monopoly power is not considered "per se" illegal under the antitrust laws. If a firm acquires monopoly power from superior skill, foresight, and industry, or if monopoly power is granted by the government, a firm will not be deemed to have committed an antitrust violation. See *United States*



tive routes roughly correspond to the twin prongs of the *du Pont* formulation, achieving supracompetitive prices by exercising either the power to control prices or the power to exclude competition. Proof of either element should suffice when market power or monopoly power is required.

### III. TOWARD A MORE PRECISE DEFINITION

None of the various judicial formulations recounted above is fundamentally erroneous. Although the standards articulated may stand at odds with each other when the courts' language is strictly interpreted, the tests they imply are not radically incompatible. Rather, most judicial formulations treat market power and monopoly power as roughly identical, but leave unclear whether they are precisely the same and, if not, which is the lesser degree of anticompetitive power. Further, reflecting the present antitrust policy consensus, these judicial definitions of market power and monopoly power focus on the phenomenon of pricing above competitive levels, but they leave unclear certain associated issues, particularly whether anticompetitive power includes the ability to prevent prices from falling or the power to exclude competition.

We believe that these marginal ambiguities and inconsistencies stem from a sensible judicial intuition that has not been clearly expressed. In brief, judges have correctly perceived that the economic power antitrust law seeks to avoid is two-dimensional; however, the distinction arises not from the type of power achieved but from the manner in which it may be exercised. Our central argument is that precision in defining this central concept in antitrust law and policy could be achieved by treating monopoly power and market power as qualitatively identical, but recognizing explicitly that anticompetitive power can be exercised by either of two methods: raising one's own prices or raising competitors' costs. These two methods of exercising market power correspond, respectively, to the "power to control price" and "power to exclude competitors" distinction expressed in the *du Pont* formulation. Both methods reduce consumer welfare.<sup>40</sup> Once this distinction is made, one then can distinguish among degrees of economic power. This quantitative

---

v. Aluminum Co. of Am., 148 F.2d 416, 429-30 (2d Cir. 1945) (no § 2 violation simply because monopoly power was thrust upon a firm). An antitrust violation will exist, however, if a firm achieves monopoly power by collusion. The method of achieving power, therefore, is of paramount importance while the label used to describe the anticompetitive economic power in question is of minimal concern.

40. See Landes & Posner, *Market Power in Antitrust Cases*, 94 HARV. L. REV. 937, 977 (1981) (suggesting a similar distinction); see also *infra* note 57 (discussing view of Landes and Posner on definition of market power in *Cellophane*); R. POSNER & F. EASTERBROOK, *ANTITRUST: CASES, ECONOMIC NOTES AND OTHER MATERIALS* 348 (2d ed. 1981) (discussing market power in *Cellophane*).

distinction, however, does not alter the conclusion that market power and monopoly power are qualitatively identical.

The core concept underlying the notion of market power or monopoly power is a firm's ability to increase profits and to harm consumers by charging prices above competitive levels.<sup>41</sup> A single firm or group of firms that is not constrained by competition from a sufficient number of equally efficient existing and potential competitors can profitably raise price or prevent price from falling in two ways.<sup>42</sup>

First, the firm or group of firms may raise or maintain price above the competitive level directly by restraining its own output ("control price"). The power to control price by restraining one's own output is the usual focus of Chicago School antitrust analysts.<sup>43</sup> For this reason, we denote the power to control price profitably, directly by restraining one's own output, as classical or "Stiglerian" market power.<sup>44</sup>

Second, the firm or group of firms may raise price above the competitive level or prevent it from falling to a lower competitive level by raising its rivals' costs and thereby causing them to restrain their output ("exclude competition"). Such allegations are at the bottom of most antitrust cases in which one firm or group of firms is claimed to have harmed competition by foreclosing or excluding its competitors.<sup>45</sup> We denote this power as exclusionary or "Bainian" market power.<sup>46</sup> Consumer welfare is reduced by the exercise of either Stiglerian or Bainian market power.<sup>47</sup>

---

41. *Jefferson Parish Hosp. Dist. No. 2 v. Hyde*, 466 U.S. 2, 27 n.46 (1984). Landes and Posner define market power as "the ability of a firm (or group of firms acting together) to raise price above the competitive level without losing so many sales so rapidly that the price increase is unprofitable and must be rescinded." Landes & Posner, *supra* note 40, at 937. Landes and Posner do not distinguish between market power and monopoly power, referring only to the "judicial definition of market power set forth in *Cellophane*." *Id.* at 977 (emphasis added).

42. Our focus generally is on price-raising conduct of a single firm. However, the analysis easily can be generalized to cooperative or collusive multifirm conduct by substituting the phrase "group of firms" for "single firm." It can also be generalized to conduct that prevents prices from falling from an initial monopoly level to the competitive level.

43. See Hovenkamp, *Antitrust Policy After Chicago*, 84 MICH. L. REV. 213, 260-83 (1985) (discussing various forms of strategic behavior that Chicago School has ignored).

44. This type of market power was extensively analyzed in G. STIGLER, *THE ORGANIZATION OF INDUSTRY* (1968).

45. See Krattenmaker & Salop, *supra* note 25, at 211-30 (discussing the approaches of courts to claims of anticompetitive exclusion).

46. See J. BAIN, *INDUSTRIAL ORGANIZATION* 324-30 (1959) (extensive analysis of these concepts); see also R. BORK, *supra* note 23, at 156 (on gaining market power by imposing costs on rivals).

47. Academic arguments might arise among antitrust theorists over which form of market power is analytically more fundamental. Those who believe that antitrust is on strongest ground in prohibiting hard core price fixing among competitors probably would focus on Stiglerian power. However, as Stigler himself and others have emphasized, successful price fixing of significant duration depends on the existence of constraints on new entry. In this sense, exclusion, either natural or as the result of deliberate, credible conduct, is the key underpinning to the exercise of market power.

We can illustrate these concepts by considering a hypothetical market for a hypothetical good called widgets.<sup>48</sup> If there are no good substitutes for widgets and only one firm produces widgets, that single firm will have the ability to exercise Stiglerian monopoly power directly by reducing its output and raising its price, and therefore the market price, to the monopoly level.<sup>49</sup> Consumer welfare and allocative efficiency are sacrificed because the firm foregoes sales to those consumers who would be willing to buy widgets at a price above the cost of production but who are unwilling to buy at the price set by the firm.<sup>50</sup>

Bainian market power can be described by altering the market structure in the previous example. Suppose instead that 100 firms with identical, rising supply curves make widgets and that each produces an equal amount. Suppose further that gadgets, a second product, are a good substitute for widgets and vice versa. Given this market structure, consider the effect of a strategy by the widget manufacturers that significantly raises the costs of manufacturing gadgets, thereby effectively removing all gadgets from the market.<sup>51</sup> This would represent an exercise in Bainian monopoly power. As the increased cost of gadgets leads gadget producers to shrink their output, the price of widgets will rise.<sup>52</sup> Widget makers will benefit as their outputs and market shares increase. Their total profits rise, while consumers lose the ability to buy gadgets at all and to buy widgets at the lower competitive price. In this example, widget firms have exercised Bainian market power, even though they could not exercise Stiglerian market power. Consumer welfare and allocative efficiency nonetheless are reduced.

From the perspective of antitrust policy, the exercise of classical, Stiglerian market power and exclusionary, Bainian market power both lead to a consumer welfare loss: restraining output below the efficient competitive level denies to consumers products that they value in excess of the marginal cost

---

Thus, Bainian power may be considered more fundamental. *See also infra* note 54 (discussing the effect of Bainian power on production efficiency).

48. These concepts are further described in the appendix, which provides a more technical illustration of the practices described here.

49. That is, to the point where marginal revenue equals marginal cost.

50. The relationship between consumer welfare and allocative efficiency is discussed in H. HOVENKAMP, *supra* note 25, at 45-49; *see* Krattenmaker & Salop, *supra* note 25, at 279-81 (discussing relevance of claims that certain exclusionary behavior is efficient).

51. For example, suppose that the widget manufacturers use relatively less labor per unit than the gadget manufacturers. If the widget manufacturers were able to cause wages to rise for both groups, this would raise disproportionately the costs of the gadget manufacturers. Thus, the widget producers can gain by achieving a relative cost advantage, even though their own costs rise. *See* Williamson, *Wage Rates as a Barrier to Entry: The Pennington Case in Perspective*, 82 Q.J. ECON. 85, 113 (1968) (wage increases can create barriers to entry).

52. As illustrated in figure 2 in the appendix, this result assumes that the supply curve of widgets is rising with output. It thus assumes that established widget manufacturers are protected by entry barriers and cannot expand output profitably at the current price level.

of production. Exercising either type of power reduces allocative efficiency and transfers wealth from consumers to the owners of the firms exercising monopoly power.<sup>53</sup> In addition, for Bainian market power, production efficiency also is reduced.<sup>54</sup>

These two sources of power over price can occur either independently or simultaneously. The first example above shows how Stiglerian power can exist independently of Bainian power; the second illustrates Bainian power without Stiglerian. However, the exercise of Bainian exclusionary power also can create classical Stiglerian power. For example, once the gadget producers' costs have been increased, they will provide a less effective constraint on tacit or express collusion by the widget producers. If the widget market is sufficiently concentrated and there are barriers to entry and expansion in the market, perhaps as a result of the cost increasing strategy, then the widget producers may be able to restrain output and raise price still further.<sup>55</sup> Finally, firms that possess Stiglerian power may be better situated to profit from raising their rivals' costs because they may stand to gain more from such a strategy than their rivals will lose.<sup>56</sup>

Stiglerian market power is fairly well understood. A firm may achieve this power from superior skill, foresight and industry, it may be thrust upon it, or bestowed by the government. It may also be achieved by collusion or merger.

Although there is virtual unanimity among antitrust commentators in the belief that classical, Stiglerian market power can be achieved through anticompetitive means, Bainian market power arising from exclusionary conduct directed against rivals is still controversial and has not yet received

---

53. This wealth transfer may be converted into an allocative efficiency loss if the producers protect or enhance their power through rent-seeking behavior and strategic entry deterrence. *See generally* Tullock, *The Welfare Costs of Tariffs, Monopolies, and Theft*, 7 W. ECON. J. 224 (1967); Posner, *Theories of Economic Regulation*, 5 BELL J. ECON. & MGMT. SCI. 335 (1974). Alternatively, it may create offsetting long run efficiency benefits by providing added incentives for cost-reducing innovations and new products in much the same way as the potential for receiving a patent increases incentives to innovate. *See* W. BOWMAN, *PATENTS AND ANTITRUST LAW: A LEGAL AND ECONOMIC APPRAISAL* 2-4 (1973).

54. Production efficiency is reduced in two ways. First, aggregate industry costs are not minimized since firms no longer produce in strict accordance with their underlying, relative costs. Second, assuming they do not exit the market altogether, disadvantaged rivals no longer produce efficiently at minimum cost. This raises the cost to society of producing their remaining output. These production efficiency losses can be substantial. Thus, the exercise of Bainian exclusionary power can be described as a form of rent-seeking that produces social losses beyond the usual dead-weight efficiency loss associated with the exercise of classical Stiglerian power. The exercise of Bainian power, however, does not always create a loss in production efficiency. Sometimes the exercise of Bainian power generates offsetting increases in the production efficiency of the excluding firm. In these cases, net production efficiency may rise or fall.

55. Krattenmaker & Salop, *supra* note 25, at 244-47.

56. *Id.* at 268-71.

extensive, systematic exposition and analysis in the antitrust literature.<sup>57</sup> Some antitrust commentators deny the real world ability to exercise Bainian market power because of a large number of factors, including allegedly pervasive and intense competition, an assumption that potentially excluded rivals can protect themselves, and a belief that suppliers and customers supposedly will be unwilling to be parties to an exclusionary strategy. Others believe that Bainian market power can never exist absent Stiglerian power.

These assertions are addressed—and, we believe, rebutted—in previous articles.<sup>58</sup> It is not our purpose to repeat the details of those analyses here. In brief, anticompetitive, exclusionary, Bainian market power occurs when an excluding firm successfully achieves two related goals. First, by denying inputs to its rivals, the excluding firm materially raises its rivals' costs. Second, by thus precluding the competitive check on its price and output decisions that those rivals provide, the excluding firm thereby gains the power to price in its output market above the competitive level. For purposes of this article, we accept these conclusions as established, but note that to date exclusionary Bainian power has been more controversial and less well understood than classical Stiglerian power.

It is this controversy, we suspect, that has led judges to be cautious in fleshing out the meanings of market power and monopoly power in antitrust opinions. Once it is understood, however, that allegations of either Stiglerian or Bainian market power make the same ultimate factual claim—that market output has been reduced to raise prices<sup>59</sup>—antitrust judges, enforcers, practitioners, and commentators should be able to agree with three propositions. First, antitrust analysis should treat market power and monopoly power as qualitatively identical—both terms refer to anticompetitive economic power. Second, antitrust analysis should distinguish clearly between classical Stiglerian and exclusionary Bainian power. Third, proof of either should satisfy the statutory requirement for market or monopoly power.

---

57. For example, as discussed *supra* note 41, Landes and Posner do not distinguish between monopoly power and market power, referring to the “judicial definition of *market power* set forth in *Cellophane*.” Landes & Posner, *supra* note 40, at 977 (emphasis added). They go on to say, “The first part of this definition [the power to control prices] seems equivalent to the economic definition of market power . . . . The second [power to exclude competition] is puzzling. The Court may just have been making the corollary point that any firm that has and exercises the power to raise price above the competitive level must also be able to exclude entrants; otherwise it would not be able to maintain the higher-than-competitive price. . . . Finally, the court may have had in mind the exclusion of equally or more efficient competitors through predatory pricing or other exclusionary practices—a dimension of the monopoly problem to which our analysis does not speak directly.” *Id.* at 977 (emphasis added).

58. Krattenmaker & Salop, *supra* note 25, at 266-77; Krattenmaker & Salop, *Analyzing Anticompetitive Exclusion*, 56 ANTITRUST L.J. 71, 82-89 (1987).

59. In special cases, market power may generate price increases unaccompanied by output reductions, such as perfect price discrimination by a monopolist.

Of course, different antitrust issues may, upon analysis, require different degrees or probabilities of anticompetitive economic power to prove a violation. For example, we may require a strong showing of a substantial degree of monopoly power before condemning practices that often can generate substantial efficiencies, but make the presence or absence of market power irrelevant in challenges to practices whose sole purpose is to suppress competition.<sup>60</sup> Similarly, a greater degree of market power may be required to constitute an antitrust violation when analyzing practices that are anticompetitive only if certain self-correcting tendencies, presumed to be operating in most markets, fail to work.<sup>61</sup> Or, to be faithful to legislative intent, we may adopt simpler approximations of market power or err on the side of overstating or understating the likelihood that a particular degree of concentration reflects monopoly power.

#### IV. RELEVANCE OF THE DEFINITION

##### A. CLARIFYING THE GOALS OF ANTITRUST

We have argued that present antitrust law lacks a clear understanding of a concept central to the application of that law—the concept of market power or monopoly power. If fostering consumer welfare is indeed the primary purpose of antitrust law, then the terms “market power” and “monopoly power” should have an identical qualitative meaning or definition: the power to price profitably above competitive levels.

Were antitrust enforcers and courts to adopt this definition, the goals of antitrust would be better specified and the application of the law clarified. Consider, for example, antitrust merger analysis. Case law establishes that corporate mergers are unlawful only to the extent that they threaten to create or facilitate the exercise of market power by firms in the market.<sup>62</sup> Defining market power exclusively as the ability to price above competitive levels would clarify that law and explain why a merger would not violate the antitrust laws simply because it would result in relocating a company’s headquarters, reducing the number of single-store firms, or enlarging a firm’s gross cash receipts. Antitrust analysts and enforcers instead would key on the relevant question of whether the merger could unreasonably increase the likelihood that market prices would rise or remain above competitive

---

60. The Supreme Court appears to express a view like this in *Northwest Wholesale Stationers v. Pacific Stationery & Printing Co.*, 472 U.S. 284, 293-98 (1985).

61. See *Krattenmaker & Salop*, *supra* note 25, at 266-72 (to determine that exclusion is anticompetitive might require that excluded firm have significantly larger market share than excluded firms, to account for possibility that excluded firms could protect themselves by counterbidding).

62. See *United States v. General Dynamics Corp.*, 415 U.S. 486, 511 (1974) (merger not unlawful when government unable to establish likelihood of substantial lessening of competition in any market).

levels.<sup>63</sup>

#### B. ANALYZING ANTITRUST CLAIMS BY DISTINGUISHING BETWEEN STIGLERIAN AND BAINIAN POWER

There remains the task of demonstrating the utility of distinguishing between the two methods of exercising market power. This section explains why courts should draw the distinction between Stiglerian and Bainian power and how doing so can clarify the structuring of antitrust inquiries, the definition of relevant markets, the measurement of market power, the treatment of unexercised market power, and competitor standing to sue.

##### 1. When Market Power is at Issue, the Inquiry Always Should Extend to Bainian, Exclusionary Power

We have argued that antitrust law would be rationally clarified if courts would recognize that anticompetitive economic power may be exercised in either of two ways: by restricting one's own output or by restricting rivals' output. Put another way, we should understand the classic *du Pont* formulation of monopoly (or market) power to mean that a plaintiff must show that the defendant has either classical, Stiglerian power or exclusionary, Bainian power.<sup>64</sup> In this sense, anticompetitive economic power is, as explained in *du Pont*, "the power to control prices or exclude competition."<sup>65</sup>

By restricting the market power inquiry to the achievement of Stiglerian power, courts unwittingly close their eyes to potential anticompetitive effects. In our judgment, courts adjudicating antitrust complaints should routinely consider whether the defendant has acquired either classical, Stiglerian power or exclusionary, Bainian power. The remainder of this article provides specific illustrations of how such an approach would facilitate the analysis of many antitrust issues.

##### 2. Market Power Cannot be a Threshold Inquiry

Analysis of market power often is treated as a threshold issue in antitrust litigation, to be carried out in an identical fashion irrespective of the defendant's alleged conduct. Indeed, certain antitrust standards call on courts to

---

63. This is the fundamental premise on which the Justice Department's merger guidelines are based. T. BRUNNER, T. KRATTENMAKER, R. SKITOL & A. WEBSTER, *supra* note 4, at 13-15. The approach described in the text would also enable those who would take account of additional factors—such as sheer firm size—to explain precisely why they would do so. Is it because the size of the firm affects consumer welfare? If not, is it because firm size can be modestly regulated without reducing consumer welfare? Or is moderating firm size an additional antitrust goal for which one must pay with some loss of consumer welfare?

64. See notes 40-54 and accompanying text (discussing definition of market and monopoly power).

65. *United States v. E.I. du Pont de Nemours & Co.*, 351 U.S. 377, 391 (1956).

evaluate the market power of the defendant before any analysis of the defendant's conduct is undertaken.<sup>66</sup> This evaluation typically involves a determination of the defendant's market share in the relevant product market along with an analysis of market concentration and entry barriers.<sup>67</sup>

This procedure is seriously flawed for a court concerned with the exercise of Bainian market power by a defendant engaged in exclusionary conduct. In these cases, the evaluation of Bainian market power is not merely the first step of the inquiry; it is the primary focus of the entire analysis. Bainian power cannot be evaluated in a vacuum, independent of and prior to analysis of the allegedly exclusionary conduct. It is the exclusionary conduct that creates the market power being evaluated, not the other way around.

Yet it is not surprising that this flawed procedure has come about. The traditional threshold test focuses on the prior achievement of Stiglerian power. Courts that erroneously think that the prior achievement of Stiglerian market power is necessary for the achievement or exercise of Bainian market power naturally assume that proof of Stiglerian market power is a threshold inquiry. However, as demonstrated earlier,<sup>68</sup> Stiglerian market power is not a prerequisite for a successful exclusionary strategy. Once this is recognized, the use of a threshold market power test in exclusion cases is unwarranted.<sup>69</sup>

### 3. Market Definition, Exclusionary Power, and the Department of Justice Merger Guidelines

Our analysis of market power up to now has not involved any explicit discussion of market definition. In conventional practice, of course, market power and market definition are closely related, because a relevant market is that group of firms that significantly constrains each other's pricing and output decisions.<sup>70</sup> The Justice Department's merger guidelines adopt that definition of relevant markets and then elaborate a methodology for applying

66. See *Aspen Skiing Co. v. Aspen Highlands Skiing Corp.*, 472 U.S. 585 (1985) (monopolization); *Jefferson Parish Hosp. Dist. No. 2 v. Hyde*, 466 U.S. 2 (1984) (tie-in sales).

67. See *Jefferson Parish Hosp. Dist. No. 2 v. Hyde*, 466 U.S. 2, 26-31 (1984) (market share of hospital insufficient to confer market power); *Ball Memorial Hosp. v. Mutual Hosp. Ins.*, 784 F.2d 1325, 1335-40 (7th Cir. 1986) (elastic supply and low market share precluded finding of market power); see also *infra* notes 99-104 and accompanying text (discussing *Cargill*).

68. See *supra* text accompanying note 52 (either type of market power can reduce allocative efficiency).

69. Similarly, this faulty approach appears to have been used in a recent article by Judge Easterbrook, in which he suggests that courts apply at a preliminary stage a number of "filters" to evaluate the plausibility of antitrust allegations of anticompetitive exclusion. One of those filters is the market power of the defendant. See Easterbrook, *The Limits of Antitrust*, 63 TEX. L. REV. 1, 14-16 (1984) (urging use of filters in antitrust). For the use of this market power filter in practice, see Judge Easterbrook's opinion in *Ball Memorial Hosp. v. Mutual Hosp. Ins.*, 784 F.2d 1325, 1334-37 (7th Cir. 1986) (market power analysis used to preclude antitrust claim).

70. T. BRUNNER, T. KRATTENMAKER, R. SKITOL & A. WEBSTER, *supra* note 4, at 83-84.



that definition to specific cases. Unfortunately, however, as presently constituted that methodology has only limited utility for analysis of allegations of Bainian power.

The Justice Department's merger guidelines<sup>71</sup> begin by taking the product of one of the merging firms and asking whether a coordinated, significant price increase above the current level by all the firms making that product would be profitable. The hypothesized increase usually is a five percent price rise lasting one year. If the hypothesized increase would be profitable, those firms constitute a relevant market.<sup>72</sup>

The most obvious problem with this approach, for cases involving claims of Bainian power, is that the guidelines will not identify as a relevant market the product of a profit-maximizing monopolist, even though such a firm may well be able to exercise Bainian power. A single firm that already is maximizing profits cannot, by definition, increase profits by raising its price further. Thus, this single firm cannot constitute a relevant market under the Justice Department's approach.<sup>73</sup> Consider, for example, the case of a firm charged with monopolization for excluding all other producers of a particular product, but which faces a competitive fringe comprised of a large number of small producers of a substitute product, each of which can produce an unlimited amount at some constant unit cost level. That firm might set its price at the level just below the value consumers place on the substitute, such that any further price increase would eliminate virtually all of its sales. As a result, under the Justice Department's test, the relevant market would include the substitute products. If the firm's share of capacity in that broader market was small, the Justice Department would conclude that it had no market power.<sup>74</sup> Because a finding of market power is a prerequisite to a section 2 violation, that firm's exclusionary conduct would be immunized.<sup>75</sup>

---

71. U.S. Dep't of Justice Merger Guidelines, *supra* note 3, at 26,827-30.

72. This same methodology is used in § 6 of the Justice Department's vertical restraints guidelines. See *Justice's Guidelines Allow Quick Look, In-Depth Look For Vertical Restrictions*, [Jan.-June] Antitrust & Trade Reg. Rep. (BNA) No. 1199, at 193, 193-95 (Jan. 24, 1985).

73. In fact, as explained below, the Justice Department's approach also cannot detect *already exercised* Stiglerian market power. One potential solution to this problem would be to expand the Justice Department's test to include the effects of price decreases in addition to price increases. If a price decrease leads to only a modest increase in sales while a price increase leads to a dramatic sales reduction for a firm or group of firms, then that firm or group of firms is likely to have already exercised Stiglerian market power.

74. While this methodology does not logically imply that the firm has no market power, the Justice Department's formulation does bias the conclusion in this direction. (It is not a logical implication, however, because in the broader market that the Justice Department would recognize, the firm could have a market share large enough to satisfy the "leading firm" proviso in ¶ 3.12 of the merger guidelines. U.S. Dep't of Justice Merger Guidelines, *supra* note 3, at 26,831).

75. Of course, this was the faulty approach taken in *du Pont*. There, the Court committed the now classic "Cellophane fallacy" first articulated by Donald Turner in his seminal article, *Antitrust*

The Justice Department's methodology should not be utilized in analyses of exclusion for a more general reason as well. Even if the firm's pricing currently is constrained by the producers of the substitute, the firm still may be able to exercise Bainian power. As discussed earlier, the firm may be able to raise its price by raising the costs of substitutes. The lack of Stiglerian market power, therefore, does not preclude the exercise of Bainian market power.

The Justice Department's test can be expanded, however, to evaluate Bainian market power. This expansion involves, first, an evaluation of the effects of allegedly exclusionary conduct on the input costs of rivals, and second, an evaluation of those increased costs on prices in the output markets in which the defendant and the excluded rivals compete. These determinations entail inquiries into both the input and output markets and the interaction between competition in the two markets. Unlike the standard methodology used by the Justice Department, the analysis of market power must involve study of the two markets in tandem. Moreover, as discussed above, this determination of market power represents the central focus of the analysis, not a threshold inquiry undertaken independently of the analysis of the defendant's conduct.

Once this commitment to the two-market analysis is made, the Justice Department's "five percent test" can be applied to Bainian market power.<sup>76</sup> The operational language can be restated as follows: Suppose the defendant succeeds in significantly raising the costs of rivals by the allegedly exclusionary conduct under consideration. Would those higher costs being borne by rivals allow the defendant profitably to raise its price by five percent? If so, the conduct can be said to permit the exercise of Bainian market power.

This evaluation involves analysis of concentration and entry barriers in the output markets in which the defendant and the excluded rivals compete. However, the analysis must account for any effects of the exclusionary con-

*Policy and the Cellophane Case*, *supra* note 35 (critical assessment of Court's decision in *Cellophane*). See Landes & Posner, *supra* note 40, at 961 (Court committed economic error in *du Pont* in its discussion of cross-elasticity of demand). In *United States v. E.I. du Pont de Nemours & Co.*, 351 U.S. 377, 394-400 (1956), the Court found that at prevailing prices cellophane was actively competing for sales with other flexible packaging material. The Court then concluded that flexible packing material and cellophane were in the same product market, and subsequently ruled that *du Pont* did not have power in this market. *Id.* at 400.

This approach is faulty because a monopolist would continue to increase its price until competition from substitutes constrains further price rises. As Judge Learned Hand observed in *Alcoa*, "There are indeed limits to [a monopolist's] power; substitutes are available for almost all commodities, and to raise the price enough is to evoke them." *Alcoa*, 148 F.2d at 425-26. Thus, the price at which competition from other flexible wrappings constrained further price increases by *du Pont* was not necessarily the competitive price for cellophane, but rather could instead have been the monopoly price.

76. See Krattenmaker & Salop, *supra* note 25, at 253-66 (on measuring the likelihood of anticompetitive effects).

duct under study because exclusionary conduct can significantly alter the competitive structure of the output market. For example, even if initially there are no entry barriers in the market, exclusionary conduct can create entry barriers by raising the costs of potential entrants. If established unexcluded competitors face barriers to expansion, or can coordinate prices successfully, then the exclusionary conduct can create market power. Similarly, the analysis of market concentration is changed. Even if the market initially is relatively unconcentrated, the competitive check provided by rivals' capacity is reduced if their costs are raised and that low cost capacity, in effect, is removed from the market. This too can lead to the exercise of market power if removal of those firms from the market leaves the market of unexcluded firms so concentrated that they can then collude successfully or restrict output unilaterally.

#### 4. Market Power Includes the Power to Prevent Price Decreases

Exclusionary conduct that reduces the likelihood of price decreases should properly be considered a form of monopoly or market power. Preventing likely price decreases reduces consumer welfare as much as causing price increases. This is important because exclusionary conduct can delay or prevent prices from falling altogether by preventing the entry or raising the costs of more efficient potential competitors.<sup>77</sup> Unfortunately, this power is not captured well by the Justice Department's method of defining markets.<sup>78</sup>

The Justice Department's "significant price increase" test would not detect the power to prevent price decreases. This inability to detect the power to prevent price decreases follows directly from the operational language of the guidelines' market definition test—the ability to raise price significantly above the current price level.<sup>79</sup>

---

77. See *Reazin v. Blue Cross & Blue Shield*, 635 F. Supp. 1287, 1315-18 (D. Kan. 1986). In this case, Blue Cross of Kansas terminated its participating hospital agreement with Wesley Hospital upon learning of the purchase of a Wichita, Kansas, health maintenance organization by Wesley's parent, Hospital Corporation of America. *Id.* at 1305. The plaintiffs alleged that the termination of Wesley's contract would both raise its costs and reduce its revenues and, by threatening other hospitals with a similar termination, deter the entry of other more efficient arrangements for providing health care and health insurance. *Id.* at 1310. Whether or not Blue Cross had Stiglerian power to increase price above the current level, such conduct could prevent prices from falling to a lower, more competitive level. (Professor Lande was an attorney and Professor Salop an economic consultant for the plaintiff in the *Reazin* case.)

78. The conclusion that the firm or group of firms lacks market power also may be invalid for merger analysis, the purpose for which the test was designed originally. Applying the Justice Department's test to a group of expressly or tacitly colluding firms that succeeded in raising the price to the monopoly level (where it is constrained by competition from substitute goods or from firms outside the cartel), the Justice Department would find the relevant market included the substitutes. Thus, the Justice Department would allow the conspirators to merge, thereby perfecting their collusion and reducing the likelihood that prices would fall in the future.

79. A similar issue also arises in merger analysis, of course. See *supra* note 78 (discussing lack of

## 5. Market Share Thresholds in Determining Market Power

The conventional test of monopoly power in cases brought under section two of the Sherman Act involves measuring the market share of the excluding firm, however the market is defined. As stated by Judge Learned Hand, a market share of ninety percent "is enough to constitute a monopoly; it is doubtful whether sixty . . . percent would be enough; and certainly thirty-three percent is not."<sup>80</sup> Use of market share as a proxy for market power has rightfully been criticized for ignoring other important market information such as the ability of competing firms to expand or of new competitors to enter.<sup>81</sup> At the extreme, the theory of contestability shows that even a firm with a 100% market share may have no ability to raise price or collect monopoly profits under certain, albeit highly restrictive, circumstances.<sup>82</sup>

More important, the use of market share for gauging the degree of Bainian market power to exclude competitors profitably by raising their costs is somewhat different than its role in detecting classical, Stiglerian market power. First, market share has independent significance and is not just a proxy for residual demand elasticity. The greater the disparity in market shares between the firm seeking to raise its rivals' costs and the rivals, the greater the firm's anticipated reward for achieving a higher price for its output. Hence, such a firm would be willing to spend more in attempting to exclude rivals to gain power over price.<sup>83</sup> It follows that, in evaluating an excluding firm's ability to outbid its rivals for the right to exclude them, the excluding firm's relative market share usually provides a helpful gauge.<sup>84</sup>

---

market power and merger analysis). By using the current price as the benchmark for its "five percent test" of market definition and market power, the Justice Department implicitly made the policy judgment that it will proscribe only those mergers that would raise prices above the current level. It will not preserve the likelihood of future price decreases by blocking mergers that may prevent the market from becoming more competitive in the future.

80. *United States v. Aluminum Co. of Am.*, 148 F.2d 416, 424 (2d Cir. 1945).

81. *See Cargill, Inc. v. Monfort of Colo., Inc.*, 107 S. Ct. 484, 495 n.17 (1986) (it is "important to examine the barriers to entry into the market, because 'without barriers to entry it would presumably be impossible to maintain supracompetitive prices for an extended time.'") (quoting *Matsushita Elec. Indus. Co. v. Zenith Radio Corp.*, 475 U.S. 574, 591 n.15 (1986)); *see also United States v. Waste Management*, 743 F.2d 976, 982 (2d Cir. 1984) (discussing effect of mergers on entry). As demonstrated by Landes and Posner and others, Stiglerian market power involves the elasticity of (residual) demand for a firm or group of firms. Market share sometimes is a highly imperfect proxy for this elasticity. Landes & Posner, *supra* note 40, at 947; *see Ordovery, Sykes & Willig, Herfindahl Concentration, Rivalry and Mergers*, 95 HARV. L. REV. 1857, 1859-63 (1982) (setting forth formula to calculate market power for individual firms). *See generally Baker & Bresnahan, The Gains from Merger or Collusion in Product-Differentiated Industries*, 33 J. INDUS. ECON. 427 (1985) (presenting mathematical approach).

82. Baumol, *On Contestable Market Analysis*, 195 CONF. BOARD RES. BULL. 13, 13 (1986). *See generally W. BAUMOL, J. PANZAR & R. WILLIG, CONTESTABLE MARKETS* (1982).

83. Krattenmaker & Salop, *supra* note 25, at 268-72.

84. If other firms are excluded, unexcluded rival firms still may be able to expand. In that case, barriers to expansion (at constant cost) for unexcluded competitors also are relevant. Under some

Further, the firms' relative purchases of inputs may provide useful information about their relative bargaining power over input suppliers in bidding for exclusionary rights.<sup>85</sup> Finally, the usefulness of market share information in analyzing Bainian market power may be hampered by the market definition problem discussed above; the market may be defined incorrectly because the "price rise" test precludes treating a true monopolist as a relevant market.<sup>86</sup>

Contrary to Judge Hand's intimation, there should be no explicit market share requirement in a section two exclusion case, although one may wish to create a "safe harbor" for cases involving trivial market shares. The inquiry should instead focus directly on the ability of the firm to raise its price by raising its rivals' costs.<sup>87</sup> Market share, therefore, provides some useful information for the analysis of Bainian market power. However, it should be one factor to consider, not the focus of the analysis.

#### 6. Legal Standards Governing the Acquisition and Exercise of Market Power

The foregoing discussion reveals that distinguishing between what we have called Stiglerian and Bainian market power also is helpful in working out the proper answer to the problem, highlighted in the *Alcoa* case, that infects analysis of monopoly claims under section two of the Sherman Act: does the statute condemn the acquisition, or merely the exercise, of monopoly power? In some important cases, the correct answer is that it depends on which type of monopoly power is at issue.

First, if a single firm achieves either Bainian or Stiglerian market power by accident, by government largess, or solely by superior skill, foresight and industry, it acquires that power lawfully, i.e., without violating section two. These conclusions follow from settled case law and from the premise that the Sherman Act is an anticonspiracy and antimonopolization statute, not an anticompetition act.<sup>88</sup>

Second, a single firm that lawfully has acquired Stiglerian market power is permitted, without violating section 2 of the Sherman Act, to exercise that

---

circumstances, the market share of a rival may provide a reasonable proxy of the barriers it faces to expansion.

85. For example, if the excluding firm ties its own input purchases to the supplier's willingness to grant exclusionary rights, then the supplier who refuses to sell the rights loses profits on the excluding firm's input sales. Thus, the supplier must compare the lost input sales to rivals if it grants exclusionary rights to the excluding firm against the lost input sales to the excluding firm if it does not. The firms' relative output market shares may provide a rough proxy for the relative losses of input sales.

86. See *supra* notes 74-75 and accompanying text (discussing "Cellophane fallacy").

87. See Krattenmaker & Salop, *supra* note 25, at 230-72 (providing details of this type of analysis).

88. See *United States v. Grinnell Corp.*, 384 U.S. 563, 571 (1966). The legislative history is more problematic than the case law. See Lande, *supra* note 11, at 91 n.105.

power by raising price and restraining its own output in that market. This follows from the argument, carefully set out by Donald Turner, that federal courts cannot take on the burden of detecting and remedying such price-setting behavior without becoming, in effect, public utility regulatory commissions.<sup>89</sup> For example, if a firm owns the only movie theater in a relevant geographic market capable of supporting only one movie theater, courts can prevent its pricing above the competitive level only by constantly monitoring the theater's prices and costs.

Third, in contrast, a single firm that has lawfully acquired Bainian exclusionary market power does not have unbridled license to exercise it. It is unclear under current law whether the exercise of Bainian power is ever permitted.<sup>90</sup> If it is, a firm lawfully may exercise Bainian power only if the resulting power over price is more than offset by gains in efficiency.<sup>91</sup> A firm that could exercise Bainian power by entering into exclusive contracts with input suppliers would not further any antitrust goal unless the exclusivity provisions of the contract also thereby reduced its own costs sufficiently to provide an efficiency justification. Moreover, unlike the difficulties facing courts in detecting and remedying Stiglerian power, the exercise of Bainian power often involves a discrete, relatively observable practice that can be detected and enjoined.<sup>92</sup>

Fourth, the Sherman Act should prevent groups of firms from acquiring either Stiglerian or Bainian market power, or a dangerous probability thereof, by collusion, joint venture, or merger, absent a showing that sufficient overriding efficiencies are expected from the horizontal combination. This follows from the related precepts that the antitrust legality of horizontal combinations should be judged antecedent to their formation and that it is administratively difficult to disentangle firms after they have been integrated.<sup>93</sup> Perhaps the law might be more permissive in permitting combinations that threaten to yield Bainian power because, in contrast to Stiglerian power, Bainian power sometimes is easier to detect and remedy when exercised.<sup>94</sup> For example, the law might proscribe combinations likely to lead

---

89. Turner, *The Definition of Agreement Under the Sherman Act: Conscious Parallelism and Refusal to Deal*, 75 HARV. L. REV. 655, 681 (1962); cf. Posner, *Oligopoly and the Antitrust Laws: A Suggested Approach*, 21 STAN. L. REV. 1562, 1588-93 (1969) (discussing problem of remedy for Sherman Act violations). Turner's objection may not apply to certain other practices.

90. Krattenmaker & Salop, *supra* note 25, at 278-79.

91. Issues concerning what efficiencies to recognize, what magnitude is necessary, what standard of liability, and what evidence should be employed are explored *id.* at 277-82.

92. See Krattenmaker & Salop, *supra* note 25, at 227-30 (defining exclusionary rights and providing examples of remediable practices); see also *infra* note 94.

93. See T. BRUNNER, T. KRATTENMAKER, R. SKITOL & A. WEBSTER, *supra* note 4, at 151-52 (discussing pre-merger notification).

94. The exercise of Bainian power is not always easier to detect and remedy than the exercise of Stiglerian power. Bainian power sometimes involves "overbuying" inputs or paying more for inputs

only to Bainian power only where entry barriers and concentration are higher.

Fifth, standards governing the exercise of Bainian market power should be more restrictive where the defendant firm or firms also have the ability to exercise Stiglerian power. This is because the existence of Stiglerian power increases the profitability, and hence the likelihood, of successfully exercising Bainian power.<sup>95</sup> It also increases the resulting efficiency losses.<sup>96</sup> This theory provides an additional rationale for more stringent standards governing potentially exclusionary Bainian conduct by firms that already have achieved significant Stiglerian market power, a "monopoly" in traditional legal parlance.

## 7. Competitor Standing

Antitrust policy in some significant measure is dependent on private enforcement for its effectiveness. Private enforcement actions are authorized, however, only for those who, because of the alleged violation, suffer "antitrust injury"; that is, the type of harm antitrust is designed to prevent.<sup>97</sup>

Recently, critics have questioned the legitimacy of allowing rivals to sue their competitors for antitrust violations.<sup>98</sup> If the conduct complained of is truly anticompetitive—that is, if it has the effect of raising or maintaining prices above competitive levels in the market—then one may ask how the complainant-rival is hurt. These critics argue that the rival firm should benefit from higher price levels. It gains the ability to choose between reducing its own output to raise price along with its malefactor-competitor or expanding its output at competitive levels to take up the slack.

This argument may be well taken when the sole asserted harm is the acquisition of Stiglerian power. Bainian power, however, can simultaneously benefit the firm that acquires it, by allowing the firm to raise price and also harm the firm's excluded rivals by raising their costs. Thus, even if competitors should presumptively be denied standing to complain of acts that allegedly threaten to create, maintain, or facilitate Stiglerian market power, no such presumption should operate in those cases where Bainian power is alleged.

In *Cargill, Inc. v. Monfort of Colorado, Inc.*,<sup>99</sup> for example, the Supreme Court held that a rival could seek to enjoin a merger of its competitors if it

---

in exchange for subtle exclusionary rights. See also *supra* note 54 (exercise of Bainian power often entails greater production inefficiencies than exercise of Stiglerian power).

95. Krattenmaker & Salop, *supra* note 25, at 266-77.

96. See *infra* text accompanying note 114.

97. *Brunswick Corp. v. Pueblo Bowl-O-Mat*, 429 U.S. 477, 489 (1977).

98. See T. BRUNNER, T. KRATTENMAKER, R. SKITOL & A. WEBSTER, *supra* note 4, at 218-20 (discussing third-party merger litigation).

99. 107 S. Ct. 484 (1986).

could show a reasonable likelihood of antitrust injury.<sup>100</sup> However, in reaching its conclusion that the plaintiff Monfort had not asserted such a claim, the Court ignored the fact that Monfort apparently alleged and the lower courts found a potentially exclusionary cost-raising strategy, instead of, or in addition to, the price-cutting tactics on which the Court focused.

Monfort's claim, stated the Court, was that defendant "Excel would bid up the price it would pay for cattle, and reduce the price at which it sold boxed beef."<sup>101</sup> The first part of this allegation ("raising the price of cattle") could be, of course, the classic technique of "overbuying" inputs, presumably to raise rivals' costs more than one's own.<sup>102</sup> Yet, in analyzing Monfort's allegations of a "cost-price squeeze," the Court focused only on the pricing component and ignored the cost element.<sup>103</sup> It therefore perceived only two potential injury theories—above-cost price predation and below-cost price predation. The Court did not discuss possible cost-raising strategies in its analysis of either theory. Thus, the Court's taxonomy and analysis of anticompetitive injury theories were incomplete.<sup>104</sup>

## V. CONCLUSION

Market power and monopoly power, as those terms are employed in antitrust law, are not separate and distinct concepts but should be understood to refer to the same phenomenon—the ability to price above the competitive level. For purposes of antitrust analysis, the crucial distinction is not between market power and monopoly power, but between two fundamentally

---

100. *Id.* at 495.

101. *Id.* at 491.

102. This could occur, for example, if the defendant (1) produced internally a significantly greater share of its own cattle, (2) protected itself with a long-term contract to purchase cattle at a fixed price, or (3) enjoyed significantly greater bargaining power over suppliers than its rivals. Under any of these circumstances, an increased price of purchased cattle would raise rivals' costs disproportionately. In addition, the purchase of cattle may be localized. If so, a large company with plants in a number of geographic markets could bid up prices of cattle in one local market without affecting the prices it paid in other markets. Rivals with plants only in the target area would find that all their cattle costs went up while the predator would face an increase only at that one plant. While it appears that there was some exploration at trial of this strategy, the *Cargill* Court does not appear to have made the critical inquiry that one would have liked.

103. We do not assert that *Cargill* was wrongly decided, just that the Court did not properly evaluate Monfort's allegations. (Whether this was the fault of the courts or Monfort's counsel is a separate issue.) Neither the Supreme Court nor the lower court opinions set out a detailed analysis of possible cost-raising allegations. Thus, we cannot tell whether the proffered allegation involved "overbuying" inputs for the purpose of raising rivals' cost or whether an increased price of cattle is simply the natural outcome of a procompetitive increase in industry output, perhaps arising out of cost savings flowing from the merger.

104. In fact, cost-raising techniques could form the basis of claims that price cuts that remain above cost can be anticompetitive. By raising its rivals' costs, the predator gains an immediate advantage in selling output without the need to sacrifice profits in the short run. Indeed, it has no need to drive the competitor out of the market. Thus, it has no need to lower its price below cost.



different ways in which a firm or group of firms may exercise anticompetitive economic power—raising one's own prices (classical Stiglerian power) or raising competitor's costs (exclusionary Bainian power).

These two types of power can be exercised singly or in tandem. Further, the presence of either type of power is likely to facilitate exercise of the other. Consequently, whenever market or monopoly power is an issue in antitrust cases, courts should inquire into both Stiglerian and Bainian power; the presence of either should suffice.

Recognizing the distinction between these two methods of exercising anticompetitive economic power also can clarify many antitrust questions, including the definition of relevant markets, the measurement of market power, the treatment of unexercised market power, and competitor standing to sue. As courts become more familiar and comfortable with the fact that Stiglerian and Bainian power both threaten consumer welfare, we expect antitrust standards to emerge that explicitly take account of these two forms of anticompetitive power.

## APPENDIX

The body of this article argues that the concepts of market power and monopoly power that antitrust law employs are not distinct concepts, but qualitatively identical ones. Both terms refer to the ability of a firm, or group of firms, to price above competitive levels.

The true, and important, distinction is between anticompetitive economic power exercised by restraining one's own output (classical, Stiglerian power) and that exercised by restricting rivals' output (exclusionary, Bainian power). This appendix restates some of the analysis behind that distinction and provides a somewhat more formal, technical illustration.

As discussed in the text, a single firm or group of firms may profitably raise price in two ways. First, it may raise price above the competitive level directly by restraining its own output ("control price"). We denote this power to raise price profitably by restraining one's own output as classical or "Stiglerian" market power. Second, a firm or group of firms may raise price above the competitive level by raising its rivals' costs and thereby causing them to restrain their output ("exclude competition"). We denote this power as exclusionary or "Bainian" market power. Either way consumer welfare is reduced because output below the efficient competitive level denies consumers products that they value in excess of the marginal cost of production and transfers wealth from consumers to producers. In addition, for Bainian market power, production efficiency also is reduced. These two sources of power over price can occur either independently or simultaneously.

We can illustrate these concepts by considering a hypothetical market for a hypothetical good called widgets. Consider Stiglerian power first. If there are no good substitutes for widgets and only one firm produces widgets, that single firm will have the ability to exercise Stiglerian monopoly power directly by reducing its output and raising its (and, therefore, the market) price to the monopoly level. This monopoly price and output occurs at the point where marginal revenue equals marginal cost. Consumer welfare and allocative efficiency are sacrificed because the firm foregoes sales to those consumers who would be willing to buy widgets, even at a price above the cost of production, but who are unwilling to buy at the monopoly price set by the firm. These consumers are harmed because they lose the ability to make these beneficial purchases. This also represents a harm to society because these benefits, which do not come at the expense of anyone else, are lost.

This is illustrated in figure 1, where the marginal cost curve of the widget monopolist is denoted by  $S$  and demand for widgets by  $D$ . As drawn, the monopolist has a constant marginal cost up to its production capacity, denoted by  $K$ . Rather than setting the competitive quantity  $Q_c$  and competitive price  $P_c$  at the point where price equals marginal cost, the monopolist sets a higher price  $P_m$  and reduces its output to  $Q_m$ , the point where marginal reve-

nue equals marginal cost.<sup>105</sup> The deadweight efficiency loss is shown by the cross-hatched triangle ABC. This is the loss in consumer surplus.<sup>106</sup>

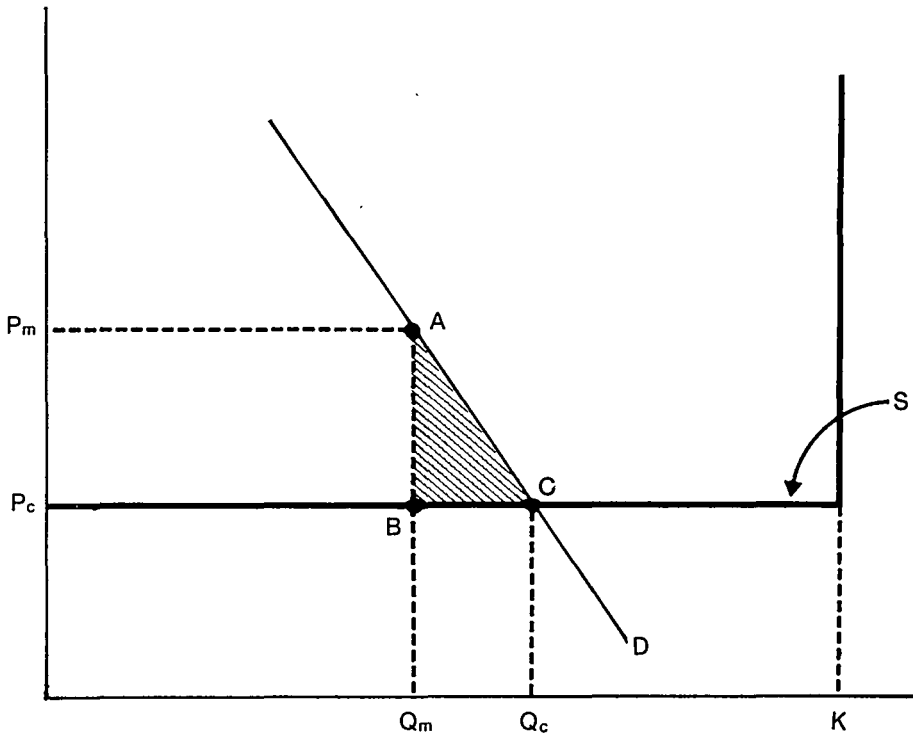

Figure 1

Exclusionary Bainian market power can be described by the following example. Suppose that 100 firms with identical, constant supply curves (constant marginal cost functions) make widgets, and that each produces an equal amount. Given this market structure, suppose further that gadgets, a second product, are the only good substitute for widgets and vice versa; gadgets and widgets therefore are in the same market. Suppose also that the widget manufacturers take steps that significantly raise the costs of manufacturing gadgets. This cost increase would represent an exercise in Bainian monopoly power.

As the increased cost of gadget production leads gadget producers to shrink their output, the price of widgets will rise. Widget makers will benefit as their outputs and market shares increase. Their total profits rise while consumers lose the ability to buy at the lower, competitive price. In this

105. For simplicity, the marginal revenue curve is not pictured in figure 1.

106. If marginal cost were rising with output, there would also be a deadweight loss in producer surplus.

example, widget firms have exercised Bainian market power, even though they could not exercise Stiglerian market power. Consumer welfare and allocative efficiency are reduced.

This is illustrated in figure 2, where S denotes the competitive supply curve of a market comprised of gadgets plus widgets. Total capacity of widget producers is denoted by  $K_G$  and total capacity of widget producers plus gadget producers is denoted by  $K$ .<sup>107</sup> The increase in the cost of gadgets is represented by the upward shift in the supply curve from S to S'.<sup>108</sup> Even if competition maintains a price where demand equals marginal cost, the price rises from  $P_1$  to  $P_2$ , while quantity falls from  $Q_1$  to  $Q_2$ . The efficiency loss involves both the deadweight loss in consumer surplus from the output reduction, illustrated by the cross-hatched area ABC<sup>109</sup> and also the loss in production efficiency, that is, the increased costs of producing the remaining output, illustrated by the cross-hatched rectangle EABF.

For firms that have both classical and exclusionary market power, these results can be derived directly from the Lerner Index.<sup>110</sup> The Lerner Index is the standard definition of the price-cost-margin of a firm in terms of its (residual) demand elasticity, or

$$L = \frac{P - MC}{P} = \frac{s}{e_d + e_s(1 - s)}$$

where L is the Lerner Index, s is the market share of the dominant firm,  $e_d$  is the market demand elasticity, and  $e_s$  is the elasticity of supply of the competitive fringe.<sup>111</sup> Exclusionary practices can be analyzed in the formula as decreases in the elasticity of supply of the fringe competitors.<sup>112</sup>

The analyses underlying figures 1 and 2 show how Bainian power and Stiglerian power can exist independently of each other. Moreover, it follows

107. Thus, the total production capacity of gadget producers is the difference,  $K - K_G$ .

108. In general, the characteristics of the upward shift in the supply curve depend on the technical characteristics of the cost increase and the incidence of the cost increase on different gadget producing firms. The "parallel" shift illustrated would arise from a constant increase in the constant marginal cost of all gadget producers, unaccompanied by any cost increase to widget producers. Thus, the supply curve only shifts up for units produced with the  $K - K_G$  capacity of gadget producers.

109. With this supply curve, there is no producer surplus.

110. The Lerner Index, named after its inventor, Abba Lerner, is the difference between price and marginal cost as a fraction of the price, or  $(P - MC)/P$ . The Lerner Index ranges from zero for a perfect competitor up to  $1/e_d$  for a monopolist, where  $e_d$  is the demand elasticity.

111. For a derivation and discussion of this formula, see Landes & Posner, *supra* note 40, at 945. See also Salop, Scheffman & Schwartz, *A Bidding Analysis of Special Interest Regulation: Raising Rivals' Costs in a Rent-Seeking Society*, in *THE POLITICAL ECONOMY OF REGULATION: PRIVATE INTERESTS IN THE REGULATORY PROCESS* 102, 106 (1984) (derivation of analogous formula for perfectly competitive market).

112. Landes & Posner, *supra* note 40, at 945.

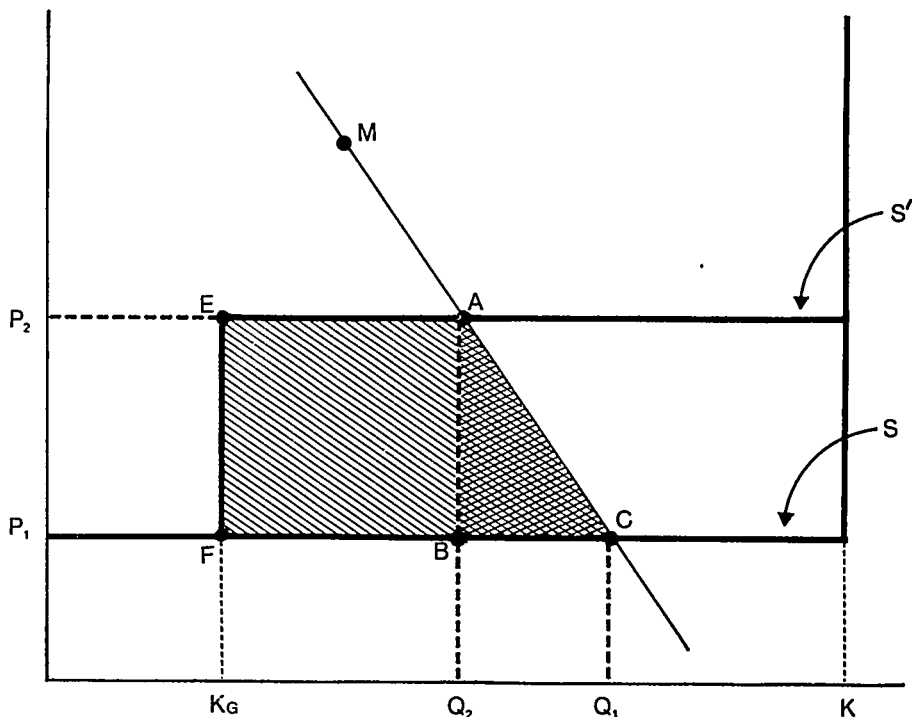

Figure 2

that the exercise of Bainian power also can create Stiglerian power. For example, once the gadget producers' costs have been increased, they will provide less of a constraint on tacit or express collusion by the widget producers. If the market is sufficiently concentrated and there are barriers to entry into that market,<sup>113</sup> perhaps as a result of the cost increasing strategy, then the widget producers may be able to restrain output and raise price still further. As illustrated in figure 2, output may fall and price may rise to the cartel level, represented by point M, leading to a further efficiency loss.

The harms from classical Stiglerian and exclusionary Bainian powers reinforce one another in a second way. The preexistence of classical Stiglerian market power also increases the size of the efficiency loss from the exercise of exclusionary Bainian market power.<sup>114</sup> This is illustrated in figure 3 for the case of constant marginal cost, denoted by S. As in figure 1, pre-existing Stiglerian market power yields an initial price P above marginal cost, and a consumer deadweight loss of ABC. Suppose, by raising rivals' costs, the firms exercising Stiglerian power are also able to exercise Bainian power and raise

113. The necessary barriers to entry and expansion are represented by the capacity constraints.

114. See Jackson, *The Consideration of Economics in Merger Cases*, 43 U. CHI. J. BUS. 439, 443 (1970) (when additional market power is added into new competitive situation, efficiency losses increase).

market price further to  $P_1$ . In that case, the additional deadweight loss in consumer surplus from the further price rise to  $P_1$  equals the cross-hatched rectangle  $FABE$  in addition to the cross-hatched triangle  $GFA$ .<sup>115</sup>

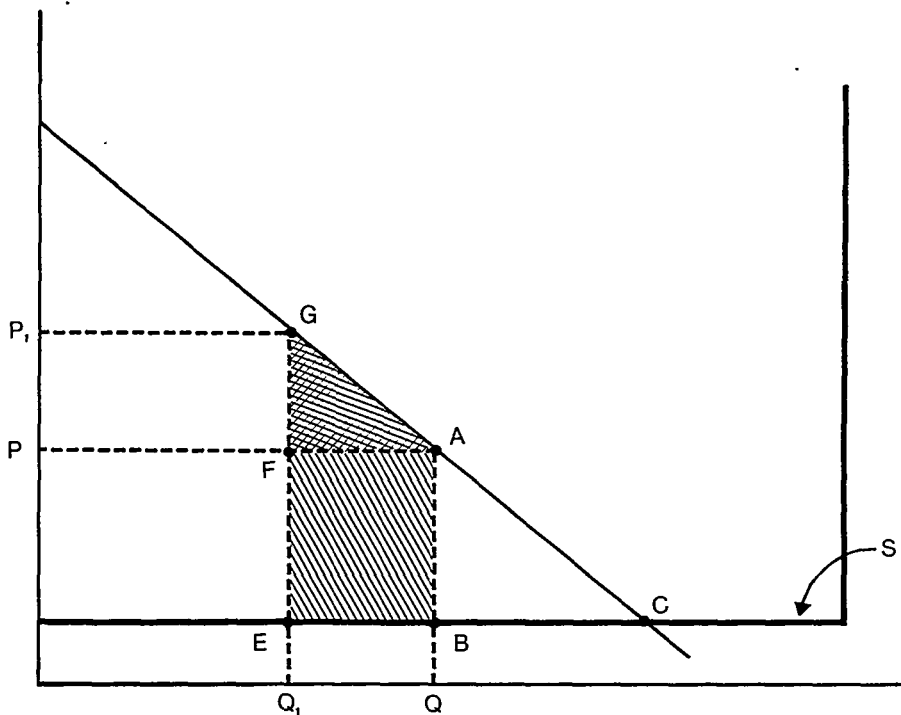

Figure 3

115. This deadweight loss is in addition to any losses in production efficiency, which are not illustrated.