



MIT Open Access Articles

Motors for Ship Propulsion

The MIT Faculty has made this article openly available. **Please share** how this access benefits you. Your story matters.

Citation	Kirtley, James L., Arijit Banerjee, and Steven Englebretson. "Motors for Ship Propulsion." Proc. IEEE 103, no. 12 (December 2015): 2320–2332.
As Published	http://dx.doi.org/10.1109/JPROC.2015.2487044
Version	Author's final manuscript
Citable link	http://hdl.handle.net/1721.1/102381
Terms of Use	Creative Commons Attribution-Noncommercial-Share Alike
Detailed Terms	http://creativecommons.org/licenses/by-nc-sa/4.0/

Motors for Ship Propulsion

James L. Kirtley Jr., *Fellow, IEEE*, Arijit Banerjee, *Student Member, IEEE* and Steven Englebretson, *Member, IEEE*

Abstract—Electric propulsion of ships has experienced steady expansion for several decades. Since the early 20th century, icebreakers have employed the flexibility and easy control of DC motors to provide for ship operations that split ice with back and forth motion of the ship. More recently, cruise ships have employed diesel-electric propulsion systems to take advantage of the flexibility of diesel, as opposed to steam engines, and because the electric plant can also be used for hotel loads. Research vessels, ferries, tankers, and special purpose vessels have also taken advantage of increased flexibility and fuel efficiency with electric propulsion. Today, the US Navy is building an ‘all electric’ destroyer to be named ‘Zumwalt’, that employs two induction motors for propulsion. There are several different classes of motors that might be considered for use in ship propulsion, ranging from DC (commutator) motors through conventional induction and synchronous motors to permanent magnet synchronous machines, doubly fed machines and superconducting AC and Acyclic Homopolar machines. This review paper describes features of some of the major classes of motor that might be used in ship propulsion.

Index Terms—Induction Motors, Synchronous Motors, DC Motors, Permanent Magnet Motors, Acyclic Motors, Ship Propulsion.

I. INTRODUCTION

Motors for Electric Ship Propulsion are, relative to most motors for industrial, commercial and residential purposes, large in terms of rating and slow in speed. Therefore, they are quite large in terms of torque. A number of different motor types have been proposed for this application, including DC (commutator) motors, induction motors, ordinary wound field synchronous motors, synchronous motors with permanent magnets serving in place of the field winding, synchronous motors with superconducting field windings, acyclic (homopolar) motors with superconducting field windings and doubly fed induction motors. Some of these, notably commutator motors, wound field synchronous (permanent magnet synchronous for smaller applications up to a few MW) and induction machines are already in use for ship propulsion, and there has been experimental development work on the others. Other machine types have been proposed, including synchronous reluctance machines and transverse flux

machines but these are ‘long shots’ in the competition for use in ship propulsion.

There is a substantial advantage in having a motor that can drive the propeller of a ship directly, not requiring a speed reducing gearbox, and we will focus on such motors in this paper. Shaft speeds range from about 100 to about 200 RPM for large ships, and power ratings per shaft range from about 12 to about 50 MW. What this means is that motors suitable for ship propulsion, having relatively low rotational speeds, will not be surface speed limited, and sizing considerations will focus on torque production. As an example, one of the latest Azipod[®] electric azimuthing podded propulsion systems made by ABB has an output of more than 20 MW at 150 RPM[1]. As smaller and smaller ships employ electric propulsion, it is expected that the range of motor ratings will become broader, extending to lower overall ratings and higher shaft speeds.

II. GENERAL SIZING CONSIDERATIONS

To start, we will attempt to get some idea of the physical size one might expect for a propulsion motor.

Consider the basic form of an electric machine as shown in **Figure 1**. This actually shows a fairly classical induction motor, but the nomenclature we will develop here could be applied to other machine morphologies. The rotor of the machine is mounted on a shaft which is supported on some sort of bearing(s). Usually, but not always, the rotor is inside. **Figure 1** shows a rotor which is round, but this does not need to be the case. The stator is, in this drawing, on the outside and has windings. With most of the machines of interest for ship propulsion, the stator winding is the armature, or electrical power input element. In ‘DC’ machines with a commutator this is reversed, with the ‘armature’, or power handling set of windings, on the inside.

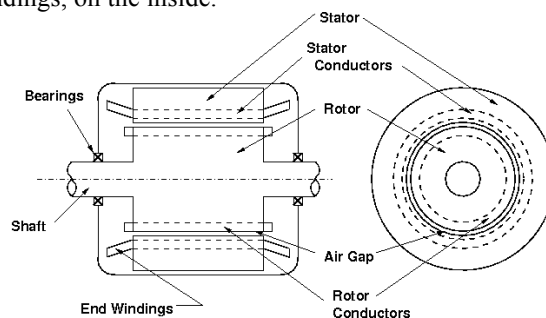

Figure 1: Form of Electric Machine

In most electrical machines the rotor and the stator are made of highly magnetically permeable materials: steel or magnetic iron. In many common machines such as induction motors the rotor and stator are both made up of thin sheets of

silicon steel. Punched into those sheets are slots which contain the rotor and stator conductors.

It is important to note for now that the machine has an air gap g which is relatively small (that is, the gap dimension is much less than the machine radius r). The air-gap also has a physical length ℓ . The electric machine works by producing a shear stress in the air-gap (with of course side effects such as production of “back voltage”). It is possible to define the average air-gap shear stress τ . Total developed torque is force over the surface area times moment (which is rotor radius):

$$T = 2\pi R^2 \ell \langle \tau \rangle$$

Power transferred by this motor is torque times speed, which is the same as force times surface velocity, since surface velocity is $u = \Omega R$, power converted is:

$$P = \Omega T = 2\pi R^2 \ell \langle \tau \rangle \Omega = 2\pi R \ell u \langle \tau \rangle$$

which is peripheral force times area times surface speed.

Active rotor volume V_R is: $\pi R^2 \ell$, so the ratio of torque to volume is just:

$$\frac{T}{V_R} = 2 \langle \tau \rangle$$

This average air-gap shear stress has a surprisingly large range of values. In his paper on the Advanced Induction Motor, the type used in the Zumwalt class of Destroyers for the US Navy, Clive Lewis cites a number of values for air-gap shear for large motors. [2] This is reproduced in **Table 1**.

Table 1: Range of Operational Shear Stress

Motor Type	Average Shear
Standard large industrial induction motor	13 kPa
High performance industrial induction motor	35 kPa
Low Speed Mill Motor	45 kPa
IPS Motor (19 MW, 150 RPM)	76 kPa
Advanced Induction Motor	100 kPa
Large Permanent Magnet Motor	120 kPa
Superconducting Synchronous Motor	340 kPa

So far, only the rotor volume V_R has been defined. To estimate the dimensions of the active machine we must make estimates of the radial extent of the armature winding (and associated teeth) and the back iron to get diameter, and then we must find the axial extent of the armature end windings.

To get started with the radial extent of the armature winding, consider the picture shown in **Figure 2**, which shows, in cartoon form, a flattened version of stator conductors in slots. This figure exaggerates the extent of tooth tips. Armature current is axial and is carried in conductors in

the slots of the armature; magnetic flux density is radial and is carried in the teeth.

Suppose both the radial flux density B_r and the stator surface current density K_z can be considered to be approximately sinusoidal flux waves of the form:

$$B_r = \sqrt{2} B_0 \cos(p\theta - \omega t)$$

$$K_z = \sqrt{2} K_0 \cos(p\theta - \omega t)$$

where B_0 and K_0 are RMS amplitudes.

Note that this assumes these two quantities are exactly in phase, or oriented to ideally produce torque, so we are going to get an “optimistic” bound here. Then the average value of surface traction is:

$$\langle \tau \rangle = \frac{1}{2} \frac{1}{2\pi} \int_0^{2\pi} B_r K_z d\theta = B_0 K_0$$

If we note λ_s as the fraction of the periphery of the machine that is slots and J_s as the RMS current density in the slots, then:

$$K_0 = \lambda_s h_s J_s$$

where h_s is slot height. Note we are ignoring the tooth tip region, assuming it to be negligible.

Similarly, if B_s is the RMS value of maximum flux density in the teeth, working flux density to make torque is $B_0 = B_s (1 - \lambda_s)$. It is a simple exercise to show that, if flux density in the teeth and current density in the slots are what define torque, the maximum torque density will occur when $\lambda_s = 0.5$.

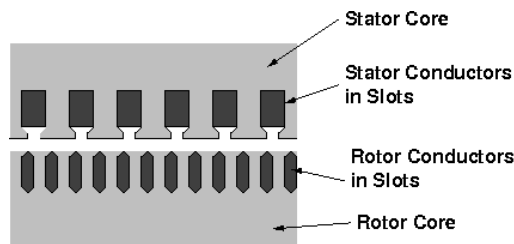

Figure 2: Windings in Slots

If the shear stress is taken as given, one can now estimate the required reaction current density:

$$K_0 = \frac{\langle \tau \rangle}{B_0}$$

So that required radial extent of the slot/tooth region would be:

$$h_s = \frac{K_0}{J_s \lambda_s} = \frac{\langle \tau \rangle}{B_s J_s \lambda_s (1 - \lambda_s)}$$

Azimuthal magnetic flux in the core of height h_c is one half of the total flux in one pole of p pole pairs, or approximately:

$$B_c h_c = \frac{R}{p} B_0$$

So the required radial extent of the core iron, assuming the core iron is operated at saturation flux density is:

$$h_c = \frac{R B_0}{p B_s}$$

Next, consider the end turn profile of the machine, as illustrated by the cartoons of **Figure 3**. The bars emerge from the ends of the stator core and are turned to go azimuthally around, to meet the opposite side bar about half way around. Neglecting short-pitching, each half bar must travel, approximately, $\frac{\pi R}{2p}$ in the azimuthal direction. The axial length associated with this travel is:

$$h_e = \frac{\pi R}{2p} \tan \phi$$

where ϕ is the angle that the bar can achieve. As shown in **Figure 3** the angle ϕ may be as small as 30 degrees, but with allowance for insulation it will likely be a bit more than that.

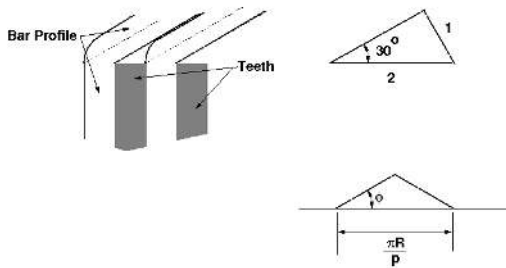

Figure 3: Rough Shape of End Turns

Rough Sizing Example

To get some idea of the physical size of the motors for ship propulsion, consider a 40 MW, 120 RPM machine. Assume a shear stress of 100 kPa as proposed by Lewis for the Advanced Induction Motor. Let's also assume this is a twelve pole ($p=6$) motor. At 120 RPM, the angular velocity is about 12.6 Radians/second, so torque that must be produced by that motor would be:

$$T = \frac{40 \times 10^6 \text{ W}}{12.6 \text{ Rad/S}} = 3.2 \times 10^6 \text{ N-m}$$

Rotor Volume is then:

$$\pi R^2 \ell = \frac{T}{2 < \tau >} = \frac{3.2 \times 10^6}{2 \times 10^5} = 16 \text{ m}^3$$

Now, if we arbitrarily decide that active length and rotor diameter are equal ($\ell = 2R$), rotor radius is easily estimated:

$$R = \sqrt[3]{\frac{16}{2\pi}} \approx 1.37 \text{ m}$$

If we assume that the steel of the stator teeth and back iron can be operated at a peak flux density of 2 T, the maximum

RMS flux density is $B_s = 2 / \sqrt{2} \approx 1.414 \text{ T}$ and air-gap flux density is $B_0 = B_s / 2 \approx 0.707 \text{ T (RMS)}$. Then the reaction surface current is

$$K_0 = 10^5 / .707 \approx 1.414 \times 10^5 \text{ A/m}$$

Now, we might rather arbitrarily assume we can achieve a superficial slot current density of, say, $2.5 \times 10^6 \text{ A/m}^2$. Active slot height is:

$$h_s = \frac{1.414 \times 10^5}{\frac{1}{2} \times 2.5 \times 10^6} \approx 0.115 \text{ m}$$

Core depth is:

$$h_c = \frac{R B_0}{p B_s} = \frac{1.37 \cdot .707}{6 \cdot 1.414} \approx 0.114 \text{ m}$$

End turn axial length, assuming a thirty degree turn angle for the end turns is:

$$h_e = \frac{\pi R}{2p} \tan \phi = \frac{\pi}{\sqrt{3}} \frac{1.37}{12} \approx 0.21 \text{ m}$$

These numbers indicate an overall diameter of 3.20 m and a length over the end turns of 3.16 m. These are electrical dimensions only and do not include provision for mounting, shafting, bearings and other things that must go along with a propulsion motor.

If made small enough, electric motors can be made to fit into propulsion pods, as shown in **Figure 4** [3]. A bit more detail on what a propulsion pod might look like is shown in **Figure 5**.



Figure 4 Podded Propulsors Drive a Cruise Ship

III. MOTOR TYPES SUITABLE FOR SHIP PROPULSION

Electric motors come in a variety of types that have different size and control characteristics. We review the major classes here and discuss how they might work in ship propulsion systems.

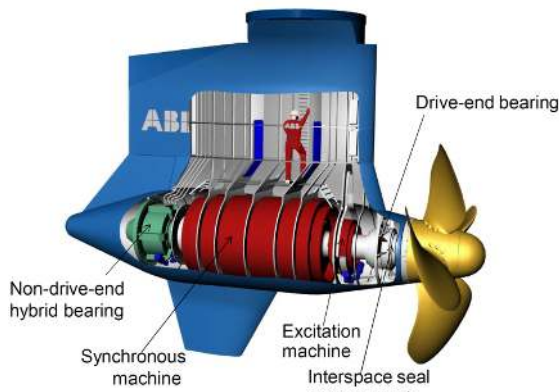

Figure 5: Podded Propulsor (Courtesy ABB)

A. DC (Commutator Motors)

Commutator machines were the first practical electric machines to be built. These machines, as well as the acyclic (homopolar) machines to be discussed below, work on the principal described by a fairly simple transformation that is consistent with observation of charged particles accelerating under the influence of both electric and magnetic fields. The electric field observed in a frame moving with respect to some other frame is:

$$\vec{E}' = \vec{E} + \vec{v} \times \vec{B}$$

where \vec{E}' is the apparent electric field in the 'moving' frame, \vec{E} is the electric field in the 'stationary' frame, \vec{v} is the velocity of the moving frame relative to the stationary frame, and \vec{B} is the magnetic flux density, the same for both frames. Thus, when a conductor is moved through a magnetic field, an electric field is induced in it. In a commutator machine, a mechanical switch, called the 'commutator' rectifies the voltage induced in the moving conductors and switches the coils of the moving armature so that they are always under the poles and so properly under the influence of the magnetic field of the field poles. A schematic representation of a DC machine armature circuit is shown in Figure 4. In this figure, the voltage induced by motion of the rotor is:

$$E_a = G\Omega I_f$$

where G is a constant that reflects the geometry and materials of the machine, I_f is current in the field winding of the motor and Ω is rotational speed.

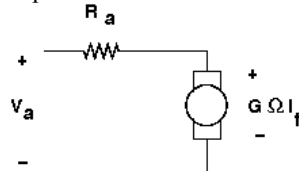

Figure 6: DC Machine Equivalent Circuit

It is pretty clear that power converted in the machine, which must be the product of torque and speed, must be also the product of internal voltage and armature current:

$$P_m = T\Omega = G\Omega I_f I_a$$

which means that torque produced is:

$$T = GI_f I_a$$

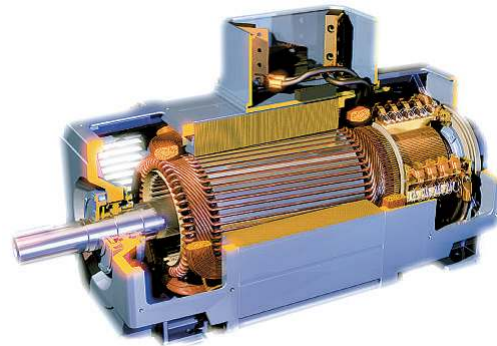

Figure 7: Cutaway View of DC Motor (Courtesy ABB)

Many DC motors have wound field windings to produce the magnetic flux of interaction. The field winding looks, electrically, like a large inductor and typically does not have any coupling with the armature winding.

Particularly in large motors, as would be used in ship propulsion, magnetic fields from the armature winding add to and impact the fields from the field winding, and in many cases compensation windings are added in the pole face of the machine to, in essence, cancel the adverse effects of the armature currents. These are shown, in cartoon form, in **Figure 9**.

The process of commutation involves turning off and then turning on currents in the coils of the armature. The commutator of a DC machine is implemented as a set of copper segments, or plates, arranged in a circle about the axis of the rotor. Rubbing on the commutator segments are two or more blocks of graphite, referred to as 'brushes'. Graphite, often modified with other substances including silver or copper, is used because it is reasonably electrically conductive and can be made to slide along the commutator segments with relatively low friction. In small motors commutation can be carried out using only the brushes of the commutator, which drive current in the coil being commutated by resistive action. But in larger motors it is often necessary to assist this process by using *commutation interpoles* that are excited by coils of wire carrying current in series with the armature. They apply pulses of voltage in the coil being commutated that drive the current in the direction of commutation. These interpoles are illustrated in **Figure 9**.

DC commutator motors have some disadvantages when considered for propulsion applications. They tend to be quite a bit larger, physically, than most other machine types of the same rating. Figure 8 shows the machine casing for the drive motor of the USS Glacier [4]. Note the doorway that gives access for maintenance, to give scale. Further, the commutator is a wear item that produces dust and is sensitive to airborne chemicals. Nevertheless, in addition to icebreakers, DC motors have been used in submarines, where they form part of a Generator/Motor system in which the generator is driven by a diesel engine and control is very simple. The generator voltage is controlled by its field current and a direct connection to the drive motor accomplishes control of motor speed. When submerged and the engine is not available, the

drive motor can be connected to a battery that provides for low speed operation. In naval submarines, it is necessary that in submerged operation the motor produce very little acoustic noise. Low noise can also be an important advantage for ocean research vessels.

Advances in machine design in recent years have improved the outlook for commutator machines, and since they work well with DC distribution systems, there are indications that they may make for more flexible, and possibly even more efficient propulsion systems for some types of ships [5].

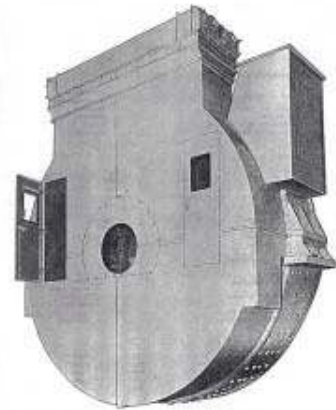

Figure 8: Machine Casing for the Westinghouse 6.3 MW Propulsion Motor of USS Glacier

DC motors are also readily and flexibly controlled with fairly simple apparatus. **Figure 10** shows how a DC motor might be controlled by two 'chopper' circuits (buck converters). Increasing the duty cycle on the armature chopper increases machine speed. Increasing the duty cycle on the field chopper strengthens the interaction field and reduces motor speed. The flexibility of control of DC motors has led them to be used for Icebreakers, where rapid control leads to more effective operation (rapid forward/reverse operation to 'ram' and break up ice formations, for example). Prior to the 1980's, diesel-electric icebreakers used DC motors.

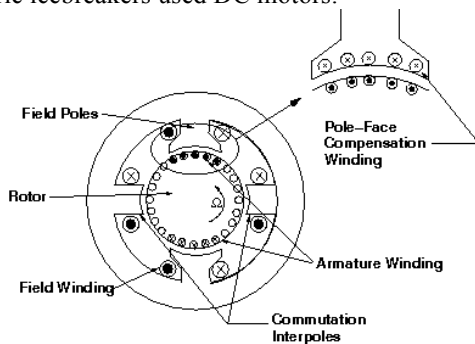

Figure 9: Commutation Interpoles and Pole Face Compensation

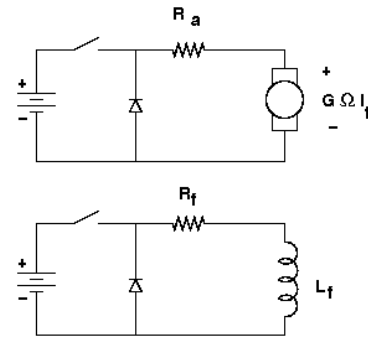

Figure 10: Two Chopper, Separately Excited Machine Hookup

IV. INDUCTION MOTORS

Induction motors are very common in industrial, commercial and residential applications. They are simple and rugged, economical to build and reasonably compact and efficient. Invented by Tesla in 1888, the polyphase induction motor was one of the reasons that Westinghouse's AC power system prevailed over Edison's DC system. It is said that about 2/3 of all generated power in modern utility systems is used to power induction motors that drive a myriad of loads, including pumps, fans, production machinery and so forth. A photograph of a relatively large, low speed induction motor built by Convertteam (now part of General Electric) is shown in **Figure 11**. This picture, stolen from [1], is similar in many design features to the motors built for DD-1000.



Figure 11: Induction Motor Similar to AIM

A cartoon view of an axial section of an induction motor is shown in Figure 8. A polyphase winding, similar to what one would see in a synchronous machine, is contained in slots in the stator. The rotor might have a winding similar to that of the stator or it might, as is shown in **Figure 12**, have a

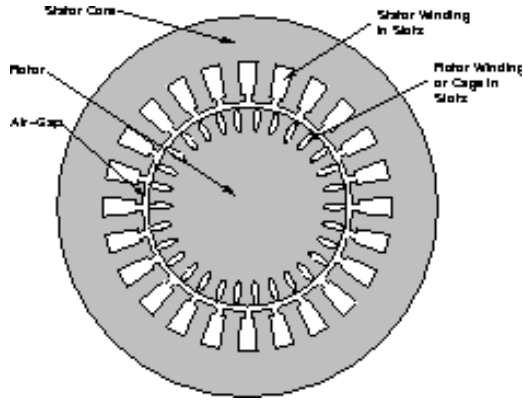

Figure 12: Axial View of an Induction Machine

simple “squirrel cage:” a number of uniformly spaced conductors around the periphery of the rotor, shorted together by conducting “end rings”. Performance of the two types of motor are similar, so the explanation of operation is usually carried out assuming the rotor has a polyphase circuit similar to that of the stator. **Figure 13** shows the situation. The stator is connected to a polyphase voltage source. The rotor is closely coupled to the stator and is turning with a rotational speed ω_m .

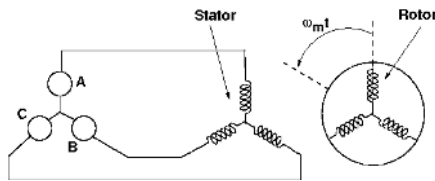

Figure 13: Conceptual Circuit Picture of an Induction Motor

In operation the polyphase voltage source produces a rotating flux wave in the stator and air-gap of the motor, and this rotating flux wave is turning at a speed with respect to the stator that is:

$$\Omega_s = \frac{\omega}{p}$$

where ω is electrical frequency and p is the number of pole pairs. In an induction motor the rotor is generally turning at a speed that is slightly less than this ‘synchronous’ speed, so the flux wave is rotating at a slower speed with respect to the rotor than with respect to the stator. The frequency experienced by the rotor is usually related to that experienced by the stator using the notion of ‘slip’:

$$\omega_r = s\omega = \omega - \omega_m = \omega - p\Omega$$

where s , a dimensionless quantity is the relative ‘slip’ between the rotor and the rotating flux wave.

The motion of the flux wave with respect to the rotor induces currents in the rotor and those currents, in turn, interact with the flux wave to produce torque. Viewed from the terminals of the stator, an equivalent circuit for one phase of the stator winding is as shown in **Figure 14**.

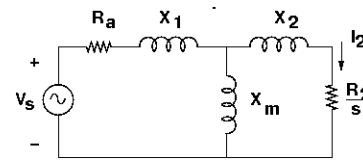

Figure 14: Equivalent Circuit for Induction Motor Operation

In **Figure 14**, the rotor equivalent resistance shows the effect of the relative frequency seen by the rotor by dividing the rotor resistance by slip. This reflects the fact that voltage induced in the rotor windings is proportional to frequency and hence to slip. It is a straightforward circuit problem to find currents in the circuit as a function of slip or rotor speed. Power crossing the air-gap must be:

$$P_{ag} = q|I_2|^2 \frac{R_2}{s}$$

where q is the number of phases, and taking I_2 to be RMS. Dissipation on the rotor must be

$$P_d = q|I_2|^2 R_2$$

and the difference between the two must be power converted from electrical to mechanical form:

$$P_{em} = q|I_2|^2 \frac{R_2}{s}(1-s)$$

Note that this power converted must also be equal to torque times speed:

$$P_{em} = T\Omega = T \frac{\omega}{p}(1-s)$$

and this leads to an expression for developed torque:

$$T = \frac{p}{\omega} q|I_2|^2 \frac{R_2}{s}$$

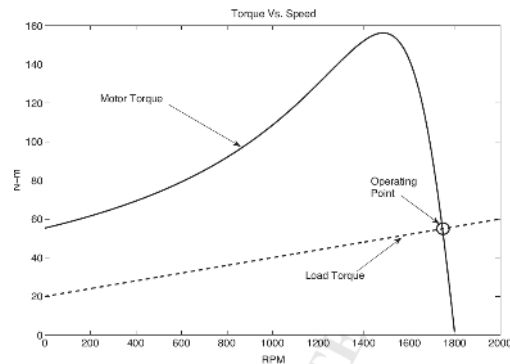

Figure 15: Induction Motor Torque vs. Speed

Figure 15 shows developed torque vs. speed for an induction motor operated against a fixed frequency voltage source. Note the motor torque matches load torque at a stable intersection at relatively low slip. This is commonly the way induction motors are operated in industrial and commercial situations. In a traction operation such as ship propulsion, in which the shaft must turn at variable speeds, it is usual to vary speed by varying drive frequency. **Figure 16** illustrates this. If

the voltage is adjusted to be proportional to frequency ('constant volts/Hz'), the torque-speed curves have nearly the same shape and peak torque. For frequencies higher than some base frequency, voltage might be held constant, in which case flux falls with speed and so does peak torque. It is to be expected that induction motor drives used to propel ships would have base speed equal to maximum speed, since propulsion force requirements rise with ship speed.

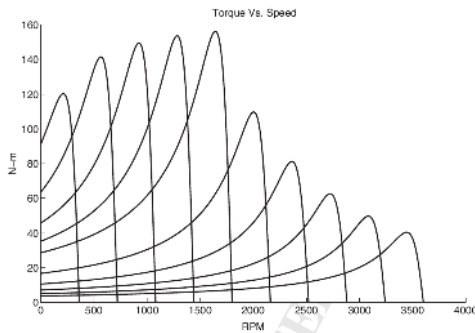

Figure 16: Variable Speed Operation

V. WOUND FIELD SYNCHRONOUS MOTORS

Synchronous machines are most often used as generators in power plants. They have stators that resemble the stator windings of induction machines, but they have rotors that carry windings with DC current. Figure 17 shows, in highly schematic and 'cartoon' form, how a synchronous machine, either motor or generator might be formulated. The rotor has a number of poles with field windings around them. The stator of the machine is not shown in the cartoon, but it would be very much like that of a similarly sized induction motor. The stator would be wound with coils consistent in number of poles with the rotor. (The cartoon of Figure 17 has two poles: a motor to propel a ship would usually have substantially larger pole count).

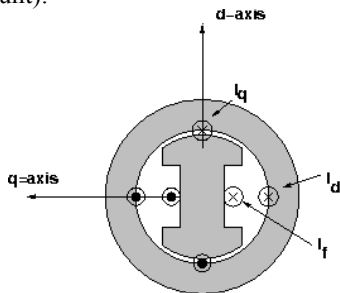

Figure 17: Synchronous Machine Cartoon

Because the synchronous machine has DC current on the rotor, it must turn at 'synchronous' speed. If there is current in the armature winding, flux linked by a phase of the armature would be, using complex amplitude notation, and ignoring any 'saliency', or dependence of inductance on rotor position:

$$\underline{\Delta}_a = L_d I_a + M I_f e^{j\theta}$$

where L_d is the inductance of the stator winding taking into account phase-to-phase mutual inductances of the stator, M is the mutual inductance between the field winding and the

stator, and the angle θ is arbitrary and accounts for the fact that the field winding may be aligned in some arbitrary fashion. Since the rotor is turning at an electrical speed of ω , voltage at the terminals of the phase is:

$$\underline{V}_a = j\omega \underline{\Delta}_a = j\omega L_d I_a + j\omega M I_f e^{j\theta}$$

Now the phase angles may be resolved: assuming that terminal voltage is real, this expression can be re-written as:

$$V_a = jX_d I_a + E_a e^{j\delta}$$

where now the angle δ is the angle of the voltage induced by the field and armature voltage.

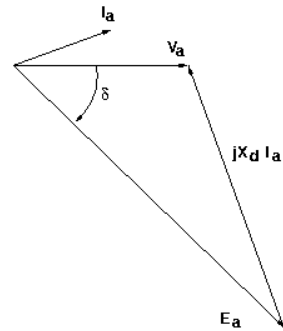

Figure 18: Voltage Diagram (KVL)

The voltage expression may be drawn in two dimensions as is shown in Figure 18. For a q-phase machine, real and reactive power at the terminals of the armature are:

$$P = -\frac{q}{2} \frac{V_a E_a}{X_d} \sin \delta$$

$$Q = \frac{q}{2} \left(\frac{V_a^2}{X_d} - \frac{V_a E_a}{X_d} \cos \delta \right)$$

For operation of a motor, the torque angle δ is negative.

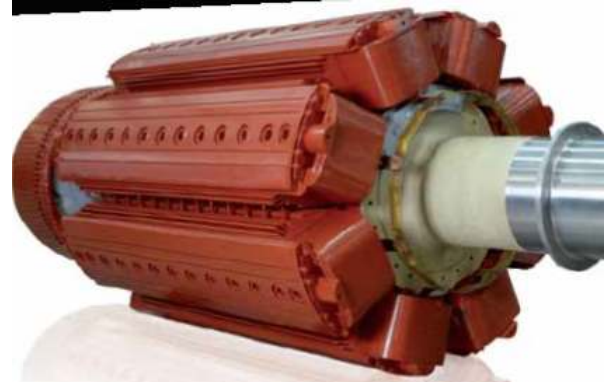

Figure 19: Synchronous Motor Rotor (Courtesy ABB)

Synchronous motors are often, at least in large sizes, a bit more efficient than induction machines. Generally their physical dimensions are about the same as induction motors. Synchronous motors require DC current to be supplied to the rotor, and that typically requires slip rings and brushes. In many cases, however, the slip rings may be avoided by providing DC current to the rotor with a 'brushless' exciter: essentially an inside out synchronous machine with the field winding on the stator, an armature winding on the rotor, and then rectifiers (often a diode bridge) on the rotor. One

advantage of synchronous machines in drive applications is that, by permitting an internal voltage that is larger than the terminal voltage, as is shown in **Figure 18**, the machine can operate at leading power factor and this can permit load commutated inverters such as cycloconverters.

VI. PERMANENT MAGNET SYNCHRONOUS MOTORS

Synchronous machines can be built with permanent magnets to provide field flux. One might think of a permanent magnet synchronous motor as being similar to a wound field motor with a fixed current source supplying the field winding. The advent of Neodymium-Iron-Boron permanent magnets, with their very high remanent magnetic flux density, permits permanent magnet machines to have operating flux densities as high as those of wound field machines. This promises shear stress at least as high as that of induction or wound field synchronous machines. However, there are some features of permanent magnet motors that must be considered [6].

1. Because permanent magnets provide flux energetically 'for free', there is no dissipation in the rotor during operation. This changes the loss budget for the machine, allowing for more dissipation in the stator for the same amount of temperature rise, and this helps to increase the shear stress, making the machine potentially smaller. It also causes the motor to have higher efficiency.
2. In many traction applications, permanent magnets do not add as much efficiency as one might think, because permanent magnet field is always 'on'. For operation at high rotational speeds (which also means high frequency), loss in magnetic iron can be quite high, and for operation at high rotational speed and low torque, the impact of iron loss can be serious. This is not a problem for ship propulsion because torque requirement increases (sharply) with speed. The propulsion motor will be designed to have its 'base' speed at maximum speed.
3. Permanent magnets provide magnetomotive force even if they are cut relatively narrowly in the azimuthal direction. They can, thus, be used to make machines with high pole counts. Wound field machines must expend ampere-turns for every pole, limiting the practical number of poles. The advantage of high pole count does not lie in an increase in air-gap shear, but in the reduction of the amount of passive magnetic material that must be used in back-iron in the stator and, potentially, in the rotor. While this will not have a big impact on motor size, it can have a dramatic impact on total motor weight, as the back iron becomes limited by structural considerations, not magnetics, and the rotor can be hollow.
4. Because a permanent magnet motor is always excited, there is a potential safety issue. In the event of a drive system fault while underway, if the motor cannot be disconnected from either the propeller or the fault, the motor will continue to drive current to the fault as long as the motor is turning. The possibility for acute damage exists. This is a topic for

continued research and development, to see if fault tolerant machine designs can be developed and proven.

VII. SUPERCONDUCTING SYNCHRONOUS MACHINES

Superconducting synchronous machines are fundamentally the same as other wound field machines, but with a few quantitative differences that approach being big enough to be qualitative [7].

Superconducting materials are known to be able to carry truly prodigious current densities: perhaps two orders of magnitude larger than can be practically carried in 'normal' conductors such as copper or aluminum. What this means is that a superconductive field winding does not need a ferromagnetic circuit to provide flux densities high enough to make a compact motor. Further, superconducting magnets dissipate little or no energy, since they have bulk resistivity that is just about zero.

Because superconducting field windings can make magnetic flux density higher than the saturation flux density of iron, it does not pay to use a magnetic circuit, and the armature winding can be built with a plastic composite structure. This leaves more room for conductors and that improves power density. The increased magnetic field also improves power density. Estimates of magnetic shear stress in excess of 300 kPa have been made, and superconducting motors have been built and tested to as high as 36.5 MW [8]. **Figure 20** shows a cartoon drawing of a superconducting motor sized for propulsion of a combatant ship [9].

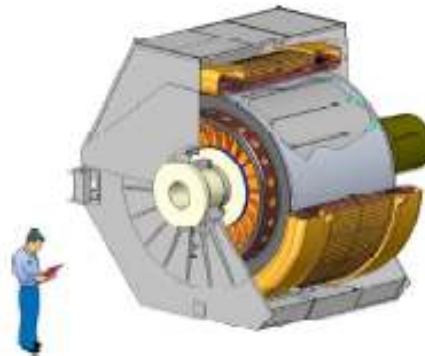

Figure 20: Cartoon of AMSC 36.5 MW motor

The flip side of this is that the field windings of these machines must be cooled to cryogenic temperatures. While many of the advanced 'high temperature' superconducting materials have transition temperatures (at which they abruptly lose essentially all resistivity) above boiling liquid nitrogen, they work better, permitting higher current density and higher magnetic flux density, if operated at lower temperatures. Cryogenic apparatus, while it is improving dramatically with time, is still somewhat 'finicky'. The issue is that at the temperatures at which superconducting field windings are likely to be operated, virtually all substances are solid. Any water, carbon dioxide, even nitrogen will turn solid if it leaks into the machine. One might anticipate the buildup of solid substances inside the machine. This type of rotor would require a rotating seal to transfer cryogenic fluids to the rotor.

A substantial amount of experience will be required to build confidence that a machine of this class will operate for a long time, reliably.

VIII. ACYCLIC (HOMOPOLAR) MOTORS

These are true DC machines that, unlike commutator machines produce both constant torque and constant back voltage. They work on the same principle as was enunciated previously for DC motors. Consider **Figure 21**, which shows a primitive version of an acyclic machine, attributed to Faraday himself. Not shown is the source of the magnetic flux, which is axial. The periphery of the machine, both at the inner and outer radius, has a continuum of current collectors that provide a uniform current that flows radially. This produces a force density that is azimuthal. A back voltage arises because of the motion of the rotor material in the magnetic field. These machines, if operated with superconducting magnets to produce the magnetic flux, can produce very high force densities. It should be noted that the kind of magnets required for this type of machine are the same as those used for medical instrumentation and have been well proven to work for long periods of time. A variation on the Faraday Disk is a drum like machine, shown in **Figure 22**.

The principal issue with the acyclic machine is that it is inherently a '1/2 turn' machine, which for low rotational speed produces low back voltage and therefore

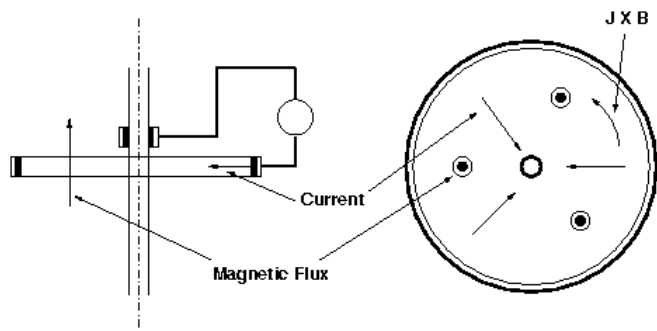

Figure 21: The Faraday Disk

has inherently high current. Further, at least one of the current interfaces must be at the maximum radius of the interaction. Development work for this class of machine has focused on the sliding current collector. Liquid metals have been tried: mercury, sodium-potassium eutectic (NAK) and gallium. Modern efforts have focused on solid metal to metal contact, using copper brushes or foils. This latter brush technology appears to be making progress [10].

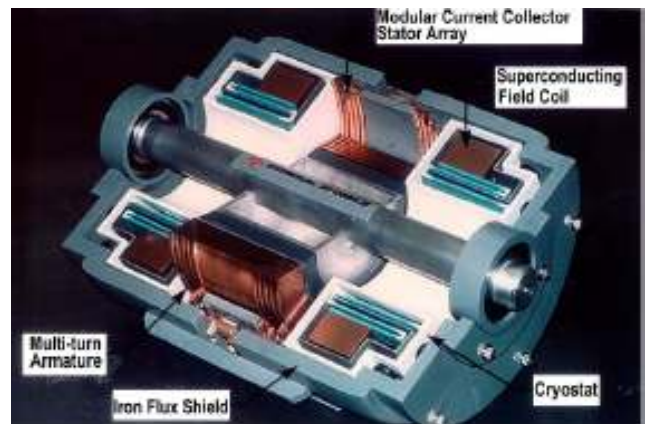

Figure 22: General Atomics Homopolar Motor Concept Model

IX. DOUBLY FED INDUCTION MOTOR

Somewhere in the gap between squirrel cage induction machines and synchronous machines is the doubly fed machine (DFM). This sort of machine was first developed to provide a limited range of adjustable speed operation to an induction motor without having to handle all of the power in a power electronics mechanism. The scheme is shown in schematic form in **Figure 23(a)**. The machine employs a wound rotor induction machine, with the rotor windings brought out through slip rings. At a high level, the DFM can be represented as a three-port electromechanical energy converter with two electrical ports and a mechanical port as shown in **Figure 23(b)**.

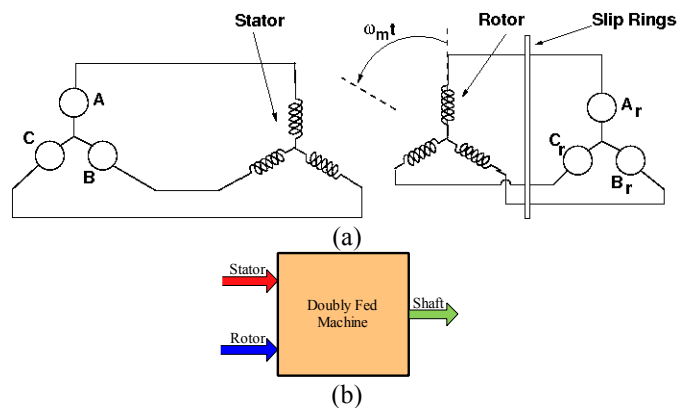

Figure 23: Doubly Fed Induction Motor: (a) Schematic, (b) Block Diagram

Often in wind turbine systems, the stator of the machine is connected to a constant frequency source (ac grid) and the rotor windings are driven by a variable frequency drive that is implemented as back to back converters (active rectifiers) with a DC link in between. This scheme provides variable shaft speed operation with a constant ac grid frequency and a controllable rotor port. With the reduced operating speed range around the ac source frequency (typically to $\pm 30\%$), the rotor variable frequency drive processes only a third of the total electromechanical power [11].

But for ship propulsion, a wide speed range of operation of the propeller is desired. We would argue to have a DFM drive which is represented by the block diagram of **Figure 24**.

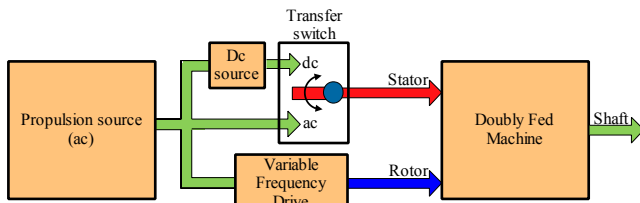

Figure 24: Doubly Fed Machine Drive Scheme Suitable for Ship Propulsion

In this scheme, the rotor is connected to the variable frequency drive, similar to a wind turbine system, while the stator can be connected to either a dc source (which is made from the ship ac source) or the ship ac source through a transfer switch. In low speed operation, with the stator connected to the dc source, a stationary flux wave is established in the stator. One can imagine the DFM in this scenario to be a traditional synchronous machine with functionality of the stator and rotor being interchanged. Assuming the ship propeller is being accelerated using a constant electromagnetic torque, the shaft normalized power is proportional to the shaft speed normalized to the ac source frequency as shown in **Figure 25**. With the dc source connected to the stator, the entire shaft power is provided from the rotor of the DFM. This is shown as dc mode in **Figure 25**. At the transition speed, that is half the ac source synchronous speed, the transfer switch flips the connection of the stator to the ship ac source, initiating the ac mode. In this mode, a constant power is fed from the stator while recovering the balance power of the shaft from the rotor. This can be imagined as a sub-synchronous operation of a standard doubly fed induction motor. As the shaft speed goes past the ac source synchronous speed, the shaft power is fed from both the stator as well as the rotor port, making this as super-synchronous operation of the DFM.

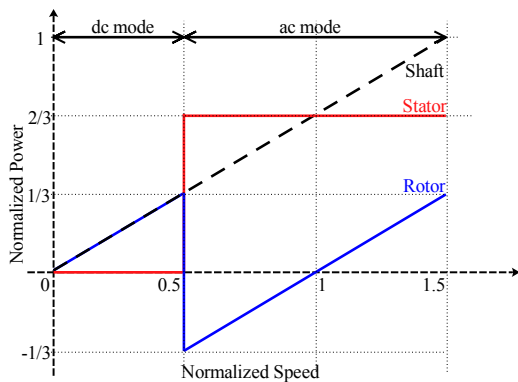

Figure 25: Sharing of the power between the three ports of the DFM: stator rotor and shaft in two different operating mode

As evident from **Figure 25**, the variable frequency drive connected to the rotor needs to be rated only for a third of the rated shaft power while operating across the complete speed range. Different design options can reduce the rotor power electronics rating to even smaller size based on the required drive torque-speed characteristics. Due to the nature of the switching involved in the stator between the two sources, this drive has been termed as “Switched” DFM drive.

A switched DFM drive can be controlled seamlessly at all speeds, including the transition speed. An SCR based transfer switch ensures ‘bumpless’ source transition without any shoot through between the sources [12].

X. CONCLUSION

Electric Propulsion has been used in ships for some time. Between the two world wars of the Twentieth Century, some battleships with steam turbine engines employed synchronous motors for propulsion, ostensibly because this obviated the need for mechanical gear reduction. The first aircraft carrier of the United States Navy, CV-1, was a conversion of a collier that had a similar propulsion system and therefore was an ‘electric ship’ [13]. Icebreakers have long used DC propulsion motors because they permit very flexible operation, including back and forth motion to ‘ram’ ice floes. When sophisticated power electronics devices became available, a move to synchronous and induction machines was made. For example, the Finnish Otso was the first icebreaker using cycloconverters and twin 7.5MW synchronous propulsion motors [5]. Similarly, cruise ships, requiring adjustable speed and frequent stops, required drive systems more flexible than steam turbine drives. They used, first, cycloconverter drives and synchronous motors that could provide load commutation for the cycloconverters. More recently, transistorized drive systems have been used with induction motors [13].

Combat ships typically require substantially larger drives than do commercial ships, and so they have been slower to adopt electric motors for propulsion, but advances in power electronics have made it possible to build a drive system with sufficient rating that now the US Navy is building an all electric destroyer with induction motor drives. The Royal Navy of the United Kingdom is also using electric propulsion in some of its newer ships.

Electric motors are particularly well suited to fit into ‘Pods’, hydraulically efficient bodies mounted below the hull of a ship [14]. They are sometimes likened to outboard motors used in small boats. Podded propulsion schemes, which are difficult to accomplish with mechanical transmissions, clean up and simplify the underside of a ship, eliminating the need for rudders and making propulsion more efficient and improving maneuverability.

References:

- [1] Azipod XO2100 and XO2300 Product Introduction. ABB Oy, Marine and Cranes, Helsinki, July 2012. [http://www05.abb.com/global/scot/scot293.nsf/veritydisplay/6c1b0250efd18e73c1257a530040dcf2/\\$file/XO2100_XO2300_Product_Intro_lowres.pdf](http://www05.abb.com/global/scot/scot293.nsf/veritydisplay/6c1b0250efd18e73c1257a530040dcf2/$file/XO2100_XO2300_Product_Intro_lowres.pdf)

- [2] C. Lewis, "The advanced induction motor," in Power Engineering Society Summer Meeting, 2002 IEEE, vol. 1, July 2002, pp. 250–253 vol.1
- [3] Lateb, R.; Takorabet, N.; Meibody-Tabar, F.; Mirzaian, A.; Enon, J.; Sarribouette, A., "Performances comparison of induction motors and surface mounted PM motor for POD marine propulsion," Industry Applications Conference, 2005. Fourtieth IAS Annual Meeting. Conference Record of the 2005, vol.2, no., pp.1342,1349 Vol. 2, 2-6 Oct. 2005
- [4] The Icebreaker USS/USCGC Glacier, Fairfield County Section
- [5] System Project Guide for Passenger Vessels, ABB OY Marine, Helsinki, Finland, February 2011, [http://www05.abb.com/global/scot/scot293.nsf/veritydisplay/608df0ae42ea2ce8c1257abd004ff506/\\$file/ABB_System_Project_Guide_Passenger_Vessels.pdf](http://www05.abb.com/global/scot/scot293.nsf/veritydisplay/608df0ae42ea2ce8c1257abd004ff506/$file/ABB_System_Project_Guide_Passenger_Vessels.pdf)
- [6] Lateb, R.; Takorabet, N.; Meibody-Tabar, F.; Mirzaian, A.; Enon, J.; Sarribouette, A., "Performances comparison of induction motors and surface mounted PM motor for POD marine propulsion," Industry Applications Conference, 2005. Fourtieth IAS Annual Meeting. Conference Record of the 2005, vol.2, no., pp.1342,1349 Vol. 2, 2-6 Oct. 2005
- [7] A. Hassannia and A. Darabi, "Design and performance analysis of superconducting rim-driven synchronous motors for marine propulsion," Applied Superconductivity, IEEE Transactions on, vol. 24, no. 1, pp. 40–46, Feb 2014
- [8] Kalsi, S.S., Gamble, B.B., Snichler, G., Ige, S.O. 'The Status of HTS Ship Propulsion Motor Developments', IEEE Power Engineering Society General Meeting, 2006
- [9] Thome, R.J.; Creedon, W.; Reed, M.; Bowles, E.; Schaubel, K., 'Homopolar motor technology development', IEEE Power Engineering Society Annual Meeting, 2002
- [10] A. Banerjee, M. Tomovich, S. LEEB, and J. Kirtley, "Power converter sizing for a switched doubly-fed machine propulsion drive," pp. 1–1, 2014.
- [11] A. Banerjee, M. Tomovich, S. Leeb, and J. Kirtley, "Control architecture for a switched doubly-fed machine propulsion drive," vol. PP, no. 99, 2014
- [12] http://en.wikipedia.org/wiki/USS_Langley_%28CV-1%29
- [13] S. Kouro, J. Rodriguez, B. Wu, S. Bernet, and M. Perez, "Powering the future of industry: High-power adjustable speed drive topologies," Industry Applications Magazine, IEEE, vol. 18, no. 4, pp. 26–39, July 2012.
- [14] W.A. Facinelli, D. Muggeridge, 'Integrated System Analysis and Design of Podded Ship Propulsors', Marine Technology, Vo. 35, No. 3, July 1999



James L. Kirtley Jr. is of Professor of Electrical Engineering at the Massachusetts Institute of Technology. He was with General Electric, Large Steam Turbine Generator Department, as an Electrical Engineer, for Satcon Technology Corporation as Vice President and General Manager of the Tech Center and as Chief

Scientist and as Director Dr Kirtley was Gastdozent at the Swiss Federal Institute of Technology.

Dr. Kirtley attended MIT as an undergraduate and received the degree of Ph.D. from MIT in 1971. Dr. Kirtley is a specialist in electric machinery and electric power systems. He served as Editor in Chief of the IEEE Transactions on Energy Conversion from 1998 to 2006 and continues to serve as Editor for that journal and as a member of the Editorial Board of the journal Electric Power Components and Systems. Dr. Kirtley was made a Fellow of IEEE in 1990. He was awarded the IEEE Third Millennium medal in 2000 and the Nikola Tesla prize in 2002. Dr. Kirtley was elected to the United States National Academy of Engineering in 2007. He is a Registered Professional Engineer in Massachusetts.



Arijit Banerjee (S'12) received the B.E. degree in electrical engineering from Bengal Engineering and Science University, Howrah, India, in 2005 and the M.Tech. degree in electrical engineering from the Indian Institute of Technology Kharagpur, Kharagpur, India, in 2007. He is currently working toward the Ph.D. degree at Massachusetts Institute of Technology, Cambridge, MA, USA.

During 2006–2007, he was a Visiting Student with the Institute for Power Electronics and Control of Drives, Technische Universität Darmstadt, Darmstadt, Germany, under a German Academic Exchange Service (DAAD) Fellowship. From 2007 to 2011, he was with the Power Conversion Systems Group, General Electric Global Research Centre, Bangalore, India, where he was working on monitoring and diagnostics of electromechanical systems using electrical signatures. In 2011, he joined the Laboratory for Electromagnetic and Electronic Systems, Massachusetts Institute of Technology. He is the holder of ten issued patents and several patent applications. His research interests include analysis, design, control, and diagnostics of electromechanical systems.



Steven Englebretson is Group Manager of the Electromagnetic Machines Group at the ABB Corporate Research Center in Raleigh, North Carolina. He worked as a research scientist at the ABB US Corporate Research Center on the design and analysis of electric machines after receiving a Ph.D. degree in Electrical Engineering in 2009 from the Massachusetts Institute of Technology and a Bachelor of Science degree in Engineering from the Colorado School of Mines in 2002.