

Multi-Criteria Decision Making for Seismic Retrofitting of RC Structures

NICOLA CATERINO¹, IUNIO IERVOLINO²,
GAETANO MANFREDI², and EDOARDO COSENZA²

¹Dipartimento per le Tecnologie, Università degli Studi di Napoli Parthenope, Naples, Italy

²Dipartimento di Analisi e Progettazione Strutturale, Università degli Studi di Napoli Federico II, Naples, Italy

The upgrading of existing structures that are not adequate to withstand seismic demand is a widely adopted and effective approach aimed at risk reduction. Nowadays, many are feasible retrofit strategies, employing traditional and/or innovative materials, and several options are available to professionals. Each one has different performances in respect to some criteria, i.e., technical and/or economical, by which each alternative can be evaluated. The selection of the most suitable retrofit strategy for a particular structure may be not straightforward since, in many applications, there is no alternative which clearly emerges among others as the best one according to the whole of the criteria considered.

Multi-Criteria Decision Making (MCDM) methods are decision-support procedures used in many fields allowing the evaluation and comparison of a set of alternatives when many evaluation criteria are involved. Ranking the alternative solutions leads to the identification of the optimal solution, which better performs in respect to all relevant goals. This article discusses how such methodological framework may be applied to the seismic retrofit of sub-standard structures. The procedure is presented via an application to an under-designed reinforced concrete (RC) building. Four different seismic upgrading alternative strategies, reflecting common as well as innovative retrofit approaches, are designed to get the required performance level and compared by using the TOPSIS – MCDM method.

Keywords Seismic Retrofit; Multi-Criteria Decision Making; Reinforced Concrete; Fiber-Reinforced Plastics; Steel Bracing; Base Isolation

1. Introduction

Existing structures in southern Europe may be inadequate in respect to the seismic performance required by the codes in force. Many of them were designed without any earthquake resistance criterion, because they were built prior to earthquake resistant building codes; others were designed to resist horizontal actions but without the principles of the *capacity design* or are built at a site in an area where the seismic hazard has been reevaluated and increased. For those cases listed, the seismic upgrading, aimed at improving the seismic performance of the structure in a way such that the seismic capacity is larger than the estimated demand, may be more convenient than demolition and re-construction.

Received 20 December 2006; accepted 13 June 2007.

Address correspondence to Nicola Caterino, Dipartimento per le Tecnologie, Università degli Studi di Napoli Parthenope, Centro Direzionale di Napoli, Isola C4, 80143 Naples, Italy; E-mail: nicola.caterino@uniparthenope.it

In recent years, innovative technologies, along with traditional solutions, have become available to the practitioners to satisfy the structural goals of retrofit, either enhancing the seismic capacity or reducing the demand. These options may be significantly different in respect of various aspects such as costs, time, structural performances, architectural impact, occupancy disruption, etc. The relative relevance of criteria is strictly dependent on the specific application and, moreover, they often represent trade-offs. Therefore, the choice of the retrofit strategy may be a not straightforward task. In the case of critical facilities, as well as for architectural heritage-belonging construction, a quantitative tool supporting the decision on the most suitable retrofit solution may provide a consistent basis for intervention design and construction management. Multi-Criteria Decision Making (MCDM) methods may be helpful in the matter. They are commonly employed to solve similar problems occurring in several fields (i.e., marketing choices, resources allocation planning, natural resources management, medical treatment selection), when the selection among a set of alternative solutions requires accounting for many criteria.

This article discusses the application of an MCDM method, known as TOPSIS (Technique for Order Preference by Similarity to Ideal Solution: Hwang and Yoon, 1981), for the selection of the optimal retrofit strategy in the case of an under-designed RC building. The decision process is made of the following eight steps which also reflect the structure of the article: (1) assessment of the un-retrofitted structure; (2) definition of the set of alternatives; (3) design of the retrofit options; (4) selection of the evaluation criteria; (5) relative weighting of the criteria; (6) evaluation of the alternatives; (7) application of the chosen MCDM method to rank the alternatives and to identify the best retrofit solution; and (8) sensitivity analysis to investigate the stability of the solution in respect to the weights of the criteria.

Some of the procedure's steps require choices which are, to a certain extent, subjective; this includes the relative weighting of the criteria and the qualitative evaluations of the alternatives. In these cases, the role of who has to choose the retrofit solution, the decision maker (DM), is important. The eigenvalue approach proposed by Saaty [1980] is used to give overall consistency to the subjective choices. Starting from linguistic judgments expressed by the DM, this approach allows the definition of the relative importance on the final decision of each criterion as well as obtaining the quantitative evaluations of criteria in respect of qualitative alternatives. Furthermore, a consistency measure of the DM's judgments ensures that no intolerable conflicts exist among them and that the final decision is logically sound and not a result of random prioritization [Shapira and Goldenberg, 2005].

As it will be clear in the following, criteria weights may be determinant for the final selection as they amplify or de-amplify the evaluation of the solutions in respect of each criterion by means of its relative importance. Therefore, a sensitivity analysis on the final result may give a quantitative measure of the actual sensitivity of the results of application of the MCDM method to the criteria weights.

The structure considered in the application is a three-story RC structure built at the European Laboratory for Structural Assessment (ELSA) of the Joint Research Center (JRC) in Ispra, Italy. This building, realized and tested for the EU project SPEAR [Fardis and Negro, 2005], is considered here as a case study, being representative of pre-seismic code constructions in southern Europe. It is supposed to be located in Pomigliano d'Arco (Naples, Italy); in 2003 [OPCM 3274], seismic classification was given to this site, and hence it may be representative of a situation in which existing structures are actually strongly deficient in terms of seismic performance and the retrofit may be required.

In the following, the nonlinear assessment of the un-retrofitted structure is presented first; then four alternatives, reflecting different seismic retrofit approaches, are designed. Three of these aim at enhancing the seismic capacity of the building according to distinct philosophies: (i) improving deformation capacity by columns' confinement with Glass Fiber Reinforced Plastics; (ii) increasing strength and stiffness by adding steel bracing; (iii) enhancing both ductility and strength by concrete jacketing of selected columns; whereas the fourth one (iv) intends to reduce the seismic demand via base isolation. Consequently, the solutions are ranked via the TOPSIS procedure, which allows the final choice of the retrofit strategy suitable for the case examined and evaluation of the stability of the results to the judgment process.

2. Description and Seismic Assessment of the Un-Retrofitted Structure

The SPEAR structure is three stories, the inter-story height is 3.0 m, an RC building designed for gravity loads only according to the design code in force in Greece between 1954 and 1995 [NEAK, 1995; NKOS, 1995]. The standard floor and the elevation view of the building are presented in Fig. 1. All the columns have square cross section ($250 \times 250 \text{ mm}^2$), except column C6 which is $750 \times 250 \text{ mm}^2$. The beams' depth is 500 mm; the slab thickness is 150 mm. The frame can be defined as a weak column-strong beam system and, therefore, it is far from the capacity design principles. The center of stiffness at each floor is away from the centre of mass, this irregularity causes torsion, while the structure can be considered regular in elevation.

Longitudinal smooth steel reinforcement is made of four $\phi 12 \text{ mm}$ bars for the columns (except C6 in which two rows of three $\phi 12 \text{ mm}$ bars close to the opposite sides of the section and two intermediate rows of two bars of the same diameter are present); the beams' reinforcement is composed by two $\phi 12 \text{ mm}$ diameter bars at the top of the section ("montage"); two $\phi 20 \text{ mm}$ bars are added at top over column C3 in beams B9 and B10; two bottom bars (three in B4) continue straight to the supports; some other 12 mm diameter bottom bars are bent up towards the supports. Stirrups are smooth $\phi 8 \text{ mm}$ bars and are 200 mm spaced in the beams, and 250 mm in the columns. They are not continued in the joints. The confinement provided by this arrangement may be considered to be poor.

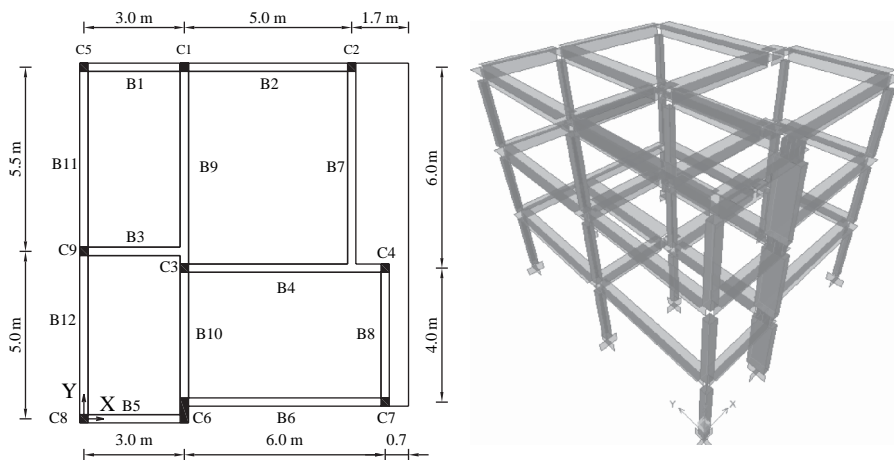

FIGURE 1 Standard floor plan and 3D view of the SPEAR building.

TABLE 1 Steel properties [Jeong and Elnashai, 2005]

| Bar diameter [mm] | Yield strength [MPa] | Ultimate strength [MPa] | Young's modulus [MPa] | Post-yield stiffness [MPa] | Ultimate strain |
|-------------------|----------------------|-------------------------|-----------------------|----------------------------|-----------------|
| 12 | 459 | 571 | 206000 | 650 | 0.174 |
| 20 | 377 | 567 | 206000 | 1147 | 0.168 |

Table 1 summarizes the assumed material properties and stress-strain relationships for steel [Jeong and Elnashai, 2005]. The compressive strength of concrete is 25 MPa. The model proposed by Mander *et al.* [1988] for the stress-strain behavior is adopted, assuming an ultimate strain equal to 0.004. Design gravity loads on slabs are 0.5 kN/m² for finishing and 2.0 kN/m² for live loads. Story masses are calculated by dividing the gravity loads (sum of dead loads and 30% of live loads) by the acceleration of gravity (g).

A finite elements model is implemented for the structure considered using the SAP2000NL 8.2.3 structural analysis software [C.S.I., 2005], beam-type elements are used. Slabs are omitted but their contribution to stiffness and strength is taken into account by assuming for the beams a T-shaped section (the effective flange width is assumed to be the beam width plus 7% of the clear span of the beam on either side of the web as in Fardis, 1994) and introducing a diaphragm-type constraint between all the joints of the same floor, which renders each floor behaving as a rigid body with no in-plane deformations. Columns at the first floor are assumed to be fully restrained at their base.

The modal analysis of the frame as built highlights that all mode shapes have significant translational components along X and Y axes, and rotational around Z, showing that the building is strongly torsionally unbalanced. The predominant modes are along X for the first mode ($T_1 = 0.52$ s), along Y for the second mode ($T_2 = 0.46$ s) and torsional around Z axis for the third mode ($T_3 = 0.37$ s).

In order to assess the building's seismic capacity and compare it with the demand¹, a lumped plasticity model was developed for the site where the structure is supposed to be located. It is obtained by introducing, at both ends of each element, a plastic hinge the nonlinear moment-rotation behavior of which is defined starting from the moment-curvature diagram of the corresponding section and adopting the expressions provided by the code. The latter allows the conversion of the curvatures (at yield and ultimate) into the corresponding chord rotations of the element.

A nonlinear static analysis (pushover) of this model is performed according to the procedure provided by the mentioned norm. A lateral force pattern proportional to the product of floor masses and the first mode along the considered axis (Fig. 2) is used to push the structure along the +X, -X, +Y, -Y directions,. Recording at each step of the analysis the base shear is acting on the structure (F_b) and the roof displacement (d_c), that is the displacement of the center of masses at the last floor, and the so-called capacity curve is obtained.

¹The seismic demand, according to the recent Italian seismic code [OPCM 3274, 2003; OPCM 3431, 2005], is defined in terms of elastic response spectrum, for which a specific shape is assigned with reference to the ground type at the site. This shape is anchored to a design value of the peak ground acceleration on rock (a_g) and amplified by a soil factor (S). The site considered classified as moderate seismicity and the site class is C according to the code, therefore a_g and S are 0.25 g and 1.25, respectively.

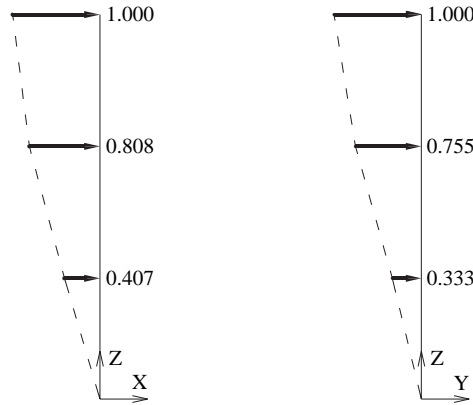

FIGURE 2 Shape of the lateral force pattern assumed for the pushover analysis along the X and Y directions (forces value normalized by the one at the top).

Figure 3 shows the capacity (or pushover) curves along the four directions with the further indication of the attainment of the limit states (LS) defined in the OPCM 3431 [2005]: (a) significant damage (SD), (b) damage limitation (DL), and (c) near collapse (NC). The DL limit state (b) is attained when the maximum interstory drift ratio is 0.005; (a) corresponds to the attainment of 3/4 of the ultimate rotation in at least one of the plastic hinges. In the following, the NC (c) (attainment of the full value of ultimate rotation) limit state will be not considered.

The seismic assessment is carried out comparing the seismic capacity and the demand by the so-called N2 method [Fajfar, 2000]. The capacity of the structure is represented by the force-displacement curve obtained by the nonlinear static analysis. The base shear forces and roof displacements are converted to the spectral accelerations and spectral displacements of an equivalent single-degree-of-freedom (SDOF) system, respectively. These spectral values define the capacity spectrum. The demands of the earthquake ground motion are defined by inelastic spectra. The acceleration-displacement response spectrum (ADRS) format is used, in which spectral accelerations are plotted against spectral displacements. The intersection of the capacity spectrum and the demand spectrum defines the performance point for the structure. In Fig. 4 with reference to the

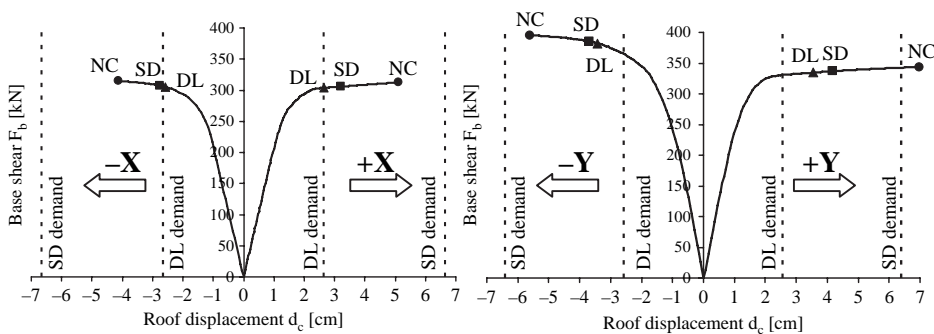

FIGURE 3 SPEAR building: pushover curves. Comparison between displacement capacity and code’s demand at each limit state, for each of the four directions $-X$, $+X$, $-Y$, $+Y$.

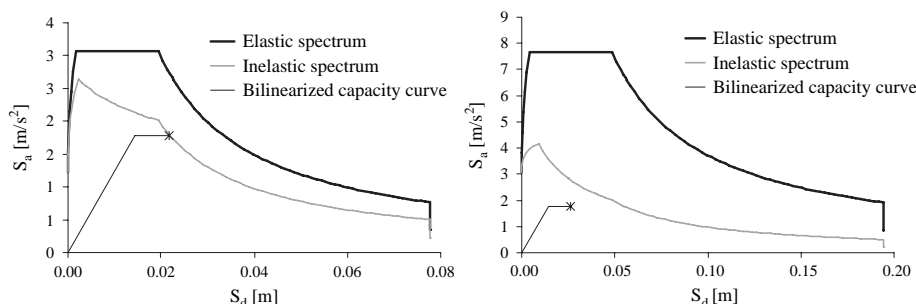

FIGURE 4 Assessment done by the N2 method for the +X direction and for the DL (left) and DS (right) limit states.

+X direction for both DL and SD limit states the application of N2 for the building considered herein is given. From the figure it is possible to conclude that the building does not satisfy the SD LS and barely withstand the DL limit state. The other six performance verifications of the total eight (4 directions \times 2 limit states) are, for sake of brevity, reported in Fig. 3 as a graphical comparison in terms of displacement capacity and corresponding inelastic demand, both referred to the original, multi-degree-of-freedom, system.

In order to improve the structure's behavior in respect of the significant damage limit state (see right panel of Fig. 4), several strategies may be chosen. Aiming at improving the capacity it is possible to enhance the global displacement capacity, the global strength, or a combination of the two. A different approach consists of reducing the seismic demand on the structure.

3. Definition and Design of a Finite Group of Alternatives

A retrofit strategy denotes an approach aiming at improving the seismic performance of an existing structure. A retrofit system is, instead, the specific method and technology used to implement the selected strategy [ATC-40, 1996; Fib bulletin No. 24, 2003]. Some so-called technical strategies modify the demand and/or the response parameters of the building. They include system completion (for structures having the basic features of an earthquake resistant building but lacking some seismic detailing), system strengthening and/or stiffening, enhancing deformation capacity, enhancing energy dissipation capacity and reducing the seismic demand. In addition, a number of alternative management strategies may also be considered. They concern approaches like destination change, or demolition, or the way in which a certain technical strategy can be implemented (e.g., temporary retrofit or phased interventions, while the structure is occupied or vacant, including exterior or interior interventions, and so on).

Focusing on the technical strategies, it is important to note that each one can be carried out in several different manners. For example, there is more than one way to add confinement to RC elements (by innovative techniques, i.e., using fiber-reinforced composite materials, or traditional, as steel or concrete jacketing) or to enhance the strength. Also, the systems able to reduce the seismic demand through the improvement of the energy dissipation capacity of the building include several different specific techniques, as well as those aiming at the base isolation. Therefore, several options are available for upgrading an existing structure and the decision maker has to select the most suitable one. Furthermore, it is hardly possible to define the best retrofit solution in absolute terms, and

the selection process strongly depends on the case under consideration. In order to make such a choice, a set of feasible alternative interventions has to be defined. Depending on the specific features of the structure and on its seismic deficiencies shown during the assessment, it will be more appropriate to include in the set of alternatives some of the alternatives rather than others. Each retrofit option has to be designed to a certain detail level in order to be effectively compared with others.

For the MCDM application included in this article, a group of four alternatives is considered, three of those aiming at a seismic capacity enhancement, the fourth one giving seismic demand reduction. In the following they will be indicated as alternatives A_1 , A_2 , A_3 , and A_4 , respectively. Solution A_1 consists of confinement by Glass Fiber Reinforced Plastics (GFRP) of columns and joints and results in an increase of the building deformation capacity; A_2 provides a global strength and stiffness enhancement by adding steel bracing; A_3 is the concrete jacketing of selected columns, which gives an improvement of both strength and ductility. The retrofit philosophy of these first three options can be graphically explained by means of the schematic representation in Figure 5 (adapted from Sugano, 1996) where (a), (b), and (c) are three different ways, practically corresponding to alternatives A_1 , A_2 and A_3 respectively, by which it is possible to lead the point (in the unsafe region) representing the original state of the building into the safe region. Finally, the seismic demand reduction is referred to as alternative A_4 and it is achieved by base isolation of the structure which lengthens the structure's fundamental period of vibration, and further adds supplemental damping. In the following sections, a brief description of the design and performance evaluation of each of the four alternative interventions is given.

3.1. Alternative A_1 : Confinement by Glass Fiber Reinforced Plastic

This first alternative is designed to increase the global deformation capacity of the building through adding confinement to columns and strengthening external joints with Glass Fiber Reinforced Plastic (GFRP). In general, this purpose can be achieved by using composites in two different ways: the first one consists of establishing a correct hierarchy of strength by relocating the potential plastic hinges; the second one aims at increasing the ductility of plastic hinges without modifying their location [CNR-DT 200, 2004]. The latter approach is adopted here. The detailed description of the composite

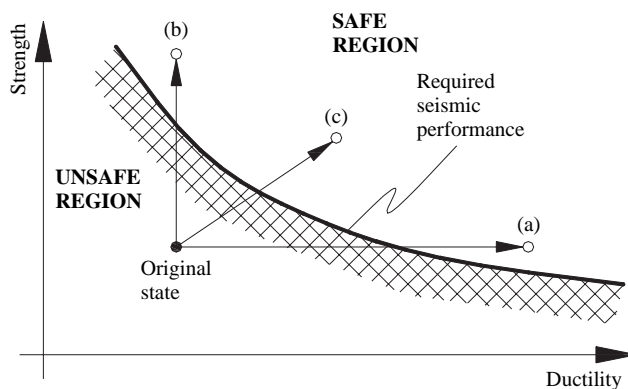

FIGURE 5 Different types of capacity improvement (adapted from Sugano, 1996).

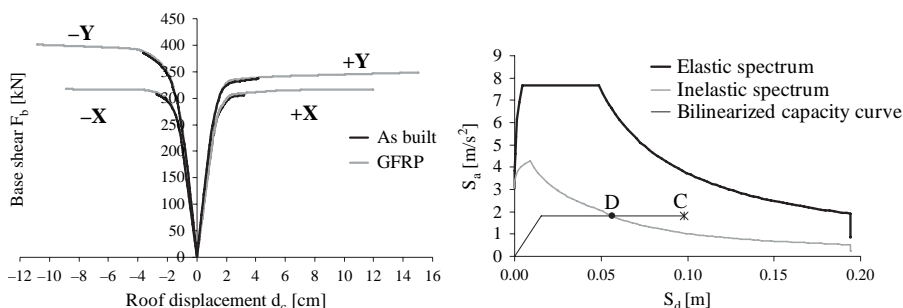

FIGURE 6 Pushover curves (SD limit state) comparison between as-built and retrofitted by GFRP structure (left). Comparison between seismic demand (D) and capacity (C) at the SD limit state of the structure upgraded by alternative A_1 and pushed along the +X direction (right).

intervention² design is reported in Cosenza *et al.*, [2005]. Two superimposed fabric layers of mono-directional glass fibers (weight 900 gr/m², thickness 0.48 mm/layer, tensile strength 2,560 MPa, longitudinal modulus of elasticity 80.7 GPa) are used for all columns, except for C6 which is strengthened by two layers of balanced four-directional glass fabric (weight 1,140 gr/m², thickness 0.11 mm/layer, tensile strength 2,600 MPa, tensile modulus of elasticity 73.0 GPa) that increase the shear capacity of this column. GFRP sheets cover a partial length (related to the local plastic hinge length) of the columns at both ends, except for C6 which is wrapped along its full length. The Spoelstra and Monti [1999] model, for the stress-strain behavior of concrete confined by FRP, was adopted. Confined concrete ultimate strain (0.007; 0.006 only for column C6) was evaluated according to the CNR-DT 200 [2004] provisions as a function of the non confined concrete ultimate strain, concrete strength, and lateral confinement. The moment-curvature relationships of wrapped sections show a significant increase in ductility, especially for those with a high value of axial load. The increase in strength is not significant, as expected. These effects reflect on the global behavior of the building, as shown in Fig. 6 (left side) where the comparison among the four pushover curves corresponding to the as-built and retrofitted by GFRP structure is given (the last point of the curves corresponds to the attainment of the SD limit state). The N2 method is adopted to compare the seismic demand (D in the right side of Fig. 6) to the capacity (C). From the performance assessment it is possible to conclude that the retrofit option A_1 achieves the capacity improvement philosophy (a) described in the previous section, since it leads the building to a safe state by enhancing only its deformation capacity, without changing the global strength.

3.2. Alternative A_2 : Steel Bracing

The retrofit option A_2 aims at increasing the global strength of the structure and at reducing the eccentricity between the center of stiffness and the center of masses. It does not induce any significant variation of displacement capacity. It consists of introducing concentric diagonal braces, as shown in Fig. 7. The chosen steel (Fe430) has yield and ultimate strengths equal to 275 and 430 MPa, respectively. The cross section selected for

²The structure retrofitted in such way was actually tested at the ELSA laboratory for the SPEAR project mentioned above.

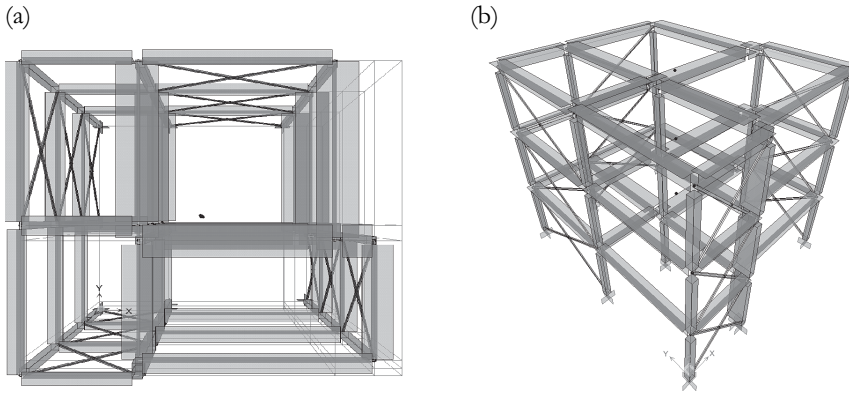

FIGURE 7 Bracing configuration: plan (a) and 3D (b).

the diagonal elements is L-shaped (65 mm \times 100 mm; 7 mm width). This choice was made according to the design criteria described by the last Italian seismic code for steel structures and imposing the use of only one cross section type for all braces, for practical reasons.

The design of the intervention was based on the following considerations: bracing of two parallel frames in each direction (X and Y) is needed to give a sufficient regularity in plan of stiffness, and thus to try to decouple the oscillation modes in the two directions; it is better to brace alternate bays so that, in case of an intense ground motion, the nodal actions due to the diagonal elements is distributed among a larger number of columns; bracing is provided in each story of the building so that the latter remains regular in elevation. According to the recommendations of the Fib bulletin No. 24 [2003], the diagonal braces are supplemented with a steel frame anchored to the surrounding concrete members (columns and beams). The horizontal steel elements (plates with section 250 \times 15 mm²) assist RC beams in resisting load effects and act as collector elements for the transfer of inertia forces to the bracing system. Vertical steel elements, with C-shaped cross section (280 mm height, 95 mm width), assist the existing RC columns [Caterino, 2006].

The comparison among the pushover curves of the original building and its configuration retrofitted by alternative A_2 is shown in Fig. 8a. Even by comparing the bilinearized capacity curves relative to the as-built and upgraded by A_2 structure (pushed up to the SD limit state attainment along the +X direction, assumed as an example; see Fig. 8b) with the elastic spectrum representing the seismic demand, it is possible to conclude that the designed intervention achieves the capacity improvement philosophy (b) described in Fig. 5, since it leads the structure to a safe state by enhancing only its global strength, without changing the lateral displacement capacity.

3.3. Alternative A_3 : Concrete Jacketing

Columns C1, C3, and C4 are selected to be strengthened by a concrete jacket 75 mm thick at each story (average concrete strength $R_{cm} = 50$ MPa, 8 longitudinal bars with diameter 16 mm, stirrups with diameter 8 mm and 150 mm spacing, 100 mm close to the joints) in order to reduce the eccentricity between the centers of strengths and masses, with the consequent reduction of harmful torsional effects in the seismic response. Figure 9 shows the location of the center of masses and that of the strengths (measured by the yielding

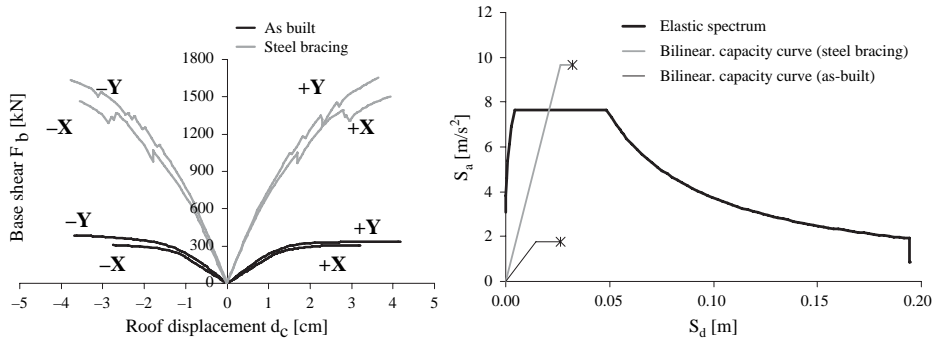

FIGURE 8 Pushover curves (SD limit state) comparison between as-built and retrofitted by steel bracing structure (left). Comparison between seismic demand and capacity at the SD limit state of the structure upgraded by alternative A_2 and pushed along the +X direction (right).

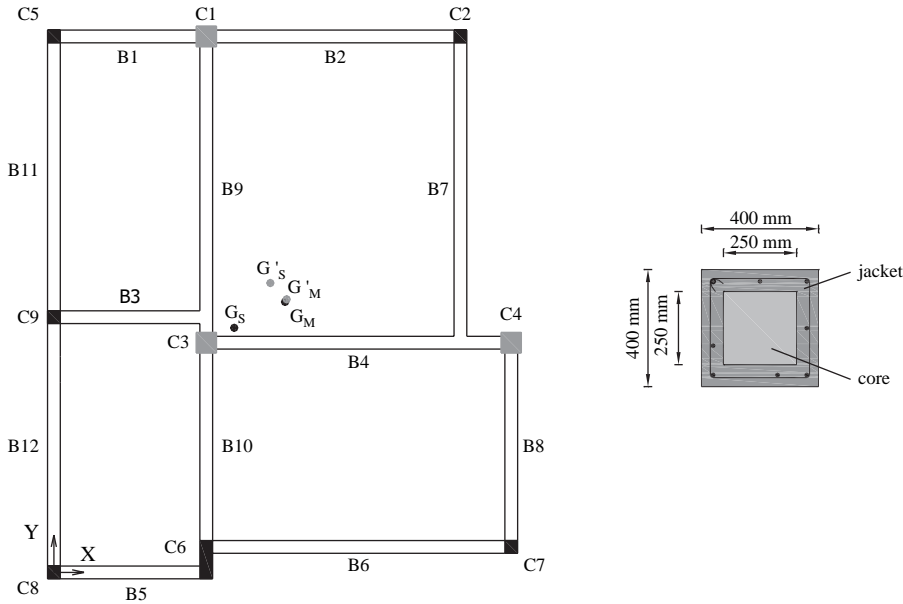

FIGURE 9 Centers of masses and strengths, for both original and retrofitted by RC jackets structure (left); cross section of a jacketed column (right).

moment of the columns) for the original structure (G_M and G_S , respectively) and for the one with the three jacketed columns (G'_M and G'_S , respectively). An increase of strength and ductility of the jacketed sections is furthermore obtained (the ultimate concrete strain is assumed 0.004 for the jacket, as for the core concrete). This reflects on the global behavior of the building, as shown by the pushover curves reported in Fig. 10 (left panel). It is important to observe that RC jacketing has to be considered as a global intervention, since the longitudinal reinforcement of the jackets passes through holes drilled in the slab and additional concrete is cast in the beam-column joints.

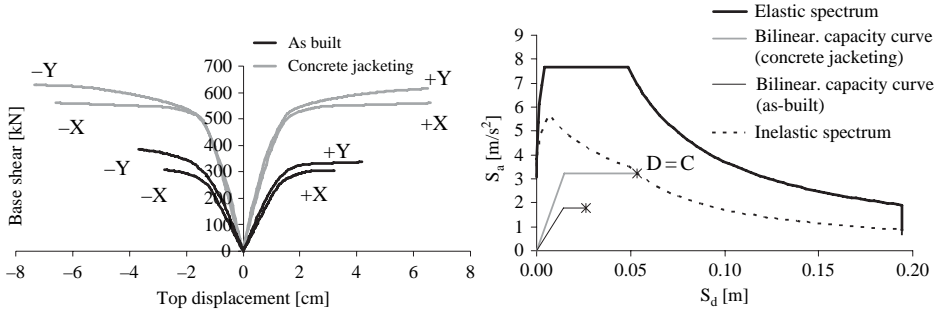

FIGURE 10 Pushover curves (SD limit state) comparison between as-built and retrofitted by A_3 structure (left). Comparison between seismic demand and capacity at the SD limit state of the structure upgraded by alternative A_3 and pushed along the +X direction (right).

As for the previous retrofit alternatives, the N2 method is adopted to compare the seismic demand with the capacity. In the right panel of Fig. 10, the verification of the SD limit state in the +X direction is carried out. The seismic demand (D) results to be practically coincident with the capacity (C), also for the other three directions.

3.4. Alternative A_4 : Base Isolation

This retrofit option is designed to reduce the seismic demand to a lower-level adequate to the present capacity of the structure. This purpose is achieved by lengthening the period of vibration and by enhancing the energy dissipation capacity through a base isolation system constituted of 9 (1 for each column) high-damping rubber bearing (HDRB) devices characterized by an effective damping ratio (ξ) equal to 10%. The superstructure capacity (0.287 g, expressed in terms of spectral acceleration) is determined starting from the pushover analysis of the original building and compared to the demand imposed by the code for the site considered ($a_g = 0.25$ g). In this way, the so-called “minimum isolated period” (that is the value of the period above which the capacity of the structure results to be greater than the seismic demand) $T_{is,min} = 1.11$ s is evaluated (Fig. 11, left) by comparing the superstructure capacity to the elastic demand represented by the elastic acceleration

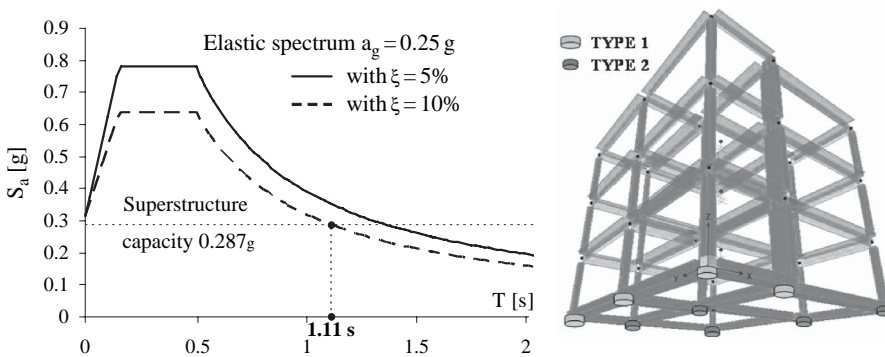

FIGURE 11 Evaluation of the “minimum isolated period” and layout of the selected devices (Types 1 and 2).

spectrum corresponding to a damping ratio equal to 10%. A selection of two different types of device, each of those characterized by a different lateral stiffness value K_h (Type 1: “soft” rubber, diameter 400 mm, $K_h = 480$ kN/m; Type 2: “normal” rubber, diameter 300 mm, $K_h = 710$ kN/m) allows the isolation of the building by a period of vibration greater than $T_{is,min}$ ($T_1 = 1.39$ s). The rational disposition of the isolators also provides centering of the elastic stiffnesses of the isolated structure with consequent decoupling of the X and Y oscillation modes.

The analysis of the structure is carried out via a modal response spectrum analysis according to the mentioned Italian seismic code. Two levels of verification of the SD and DL limit states is needed. The first level refers to the superstructure and it is analogous to the assessment of a fixed-base building in seismic area (strength of each element for the SD limit state, interstory drift ratio for the DL limit state). The second check is related to the devices. In this case, the SD limit state is considered attained if the demand in terms of horizontal displacement reaches a limit threshold according to the devices’ producer. The DL limit state verification of the isolators is assumed to be automatically satisfied if the DS limit state is satisfied [OPCM 3431, 2005].

Since the PGA values needed for the attainment of the SD and DL limit states in the superstructure are larger than those relative to the isolator units, the global capacity of the isolated building will be referred to the latter. Furthermore, given the definition of DL for the devices, the PGA capacity values at the SD and DL assume the same value. Finally, it is important to underline that the superstructure remains elastic up to the SD limit state attainment.

4. Definition of the Evaluation Criteria

After the definition and design of the retrofit options (Steps 2 and 3 of the MCDM procedure), choosing the evaluation criteria (Step 4) must be done. Criteria can be generally defined as different points of view from which the same solution can be evaluated. According to Thermou and Elnashai [2002], criteria can be grouped into two categories: economical/social and technical criteria. Only the criteria that may have a significant influence on the final decision should be considered. They depend on the specific feature of the building and on its destination. Since the building under examination is supposed to be for residential use and the DM is assumed to be the owner, the criteria in the following Table 2 have been selected.

Therefore, obviously, the total cost to be beared for the realization of each alternative has to be taken into account to compare the retrofit options (criterion C_1). But, in a multi-criteria approach, the deferred expenses to be incurred during the economic life of

TABLE 2 Evaluation criteria

| Group | Symbol | Description |
|---------------------|--------|--|
| Economical / Social | C_1 | Installation cost |
| | C_2 | Maintenance cost |
| | C_3 | Duration of works/disruption of use |
| | C_4 | Functional compatibility |
| Technical | C_5 | Skilled labour requirement/needed technology level |
| | C_6 | Significance of the needed intervention at foundations |
| | C_7 | Significant Damage risk |
| | C_8 | Damage Limitation risk |

the building and needed to preserve its original functionality also have to be considered (criterion C_2). The time span necessary to realize each intervention, as well as the disruption of normal building activities it causes, are of course other important aspects to take into account. In the case under examination, the duration of the retrofit installation is considered to cause disruption of use of the building. Furthermore, the functional compatibility of each retrofit option to the existing building also has to play a decisive role in the procedure since it concerns the architectural impact that an intervention implies. Only a qualitative evaluation of alternatives in respect of this criterion (C_4) will be possible and thus its conversion into quantitative terms will be needed.

Alternatives may be discriminate with respect to the skilled labor requirement and the technology level needed for their realization (criterion C_5). It is appropriate to take into account, by means of a specific criterion (C_6), the size of the eventual intervention at foundation for each alternative, since the generally considerable difficulty of realization and costs.

Seismic performance of the upgraded building according to one of the retrofit options is taken into account by evaluating the risk of SD LS attainment (criterion C_7), and the risk of non structural damage to repair, during the economic life of the structure (criterion C_8). Other details about criteria and the specific way of measuring the alternatives' performances according to them will be discussed in the following sections.

Besides the described criteria, others could be considered in the procedure. For example, an additional criterion may be related to the reparability of the retrofiting building after the occurrence of an earthquake inducing the attainment of the SD limit state.³

5. Weighting the Evaluation Criteria

A quantitative evaluation of the relative importance (weight) of each criterion to the final decision is needed. The weights will amplify or de-amplify the evaluations of the alternatives in order to reflect how much each criterion is important relatively to the others in the choice of the best solution. Therefore this step, necessarily involving DM's choices, requires special attention.

The approach used herein to compute weights w_i of the criteria C_i ($i = 1, 2, \dots, 8$) is proposed by Saaty [1980] and is based on pairwise comparisons of criteria and eigenvalues theory. It requires the DM expressing his opinion about a pairwise comparison at a time. In particular, with reference to two generic criteria C_j and C_k ($j, k = 1, 2, \dots, 8$), the DM has to define the relative importance of C_j in respect of C_k choosing among 17 possibilities. Each choice is a linguistic phrase, such as those reported in the second column of Table 3. Then, adopting the linear scale shown in the same table, the linguistic statement can be converted into a crisp number a_{jk} , which is an element of the following set:

$$\{1/9, 1/8, 1/7, 1/6, 1/5, 1/4, 1/3, 1/2, 1, 2, 3, 4, 5, 6, 7, 8, 9\} \quad (5.1)$$

The value of a_{jk} can be considered as a rough estimate of the w_j/w_k ratio. Therefore, a_{jk} is equal to 1 when criteria C_j and C_k are judged to be equally important; greater than 1, if C_j is considered to be more important than C_k ($a_{jk} \in \{2, \dots, 9\}$); lower than 1, if C_j is considered to be less important than C_k ($a_{jk} \in \{1/9, \dots, 1/2\}$). In the last row of Table 3 is underlined that two criteria have to be compared one time only since it should be assumed

³For example, the building retrofitted by base isolation may be repaired through the replacement of some or all the devices, since the superstructure is likely to remain elastic.

TABLE 3 Scale of relative importance [Saaty, 1980]

| Intensity of Importance | Definition |
|-------------------------|---|
| 1 | Equal importance |
| 3 | Moderate importance of one to another |
| 5 | Essential or strong importance |
| 7 | Demonstrated importance |
| 9 | Extreme importance |
| 2, 4, 6, 8 | Intermediate values between the two adjacent judgements |
| Reciprocal of above | If criterion <i>j</i> compared to <i>k</i> gives one of the above, then <i>k</i> , when compared to <i>j</i> , gives its reciprocal |

$a_{kj} = 1/a_{jk}$. After defining all the a_{jk} values⁴, they can be assembled into the matrix (**A**), which results to be a symmetric square matrix of order *n* (*n* = 8 herein because 8 is the number of compared criteria). For the case under consideration, 28 comparisons between criteria in terms of relative importance have been performed, simulating a likely behavior of the DM, and the **A** matrix given in Eq. (5.2) was obtained.

$$\mathbf{A} = [a_{ij}] = \begin{bmatrix} 1 & 1/3 & 1 & 1/5 & 4 & 1/3 & 4 & 1/3 \\ 3 & 1 & 3 & 1/2 & 6 & 1 & 6 & 1 \\ 1 & 1/3 & 1 & 1/5 & 4 & 1/3 & 4 & 1/3 \\ 5 & 2 & 5 & 1 & 6 & 2 & 5 & 2 \\ 1/4 & 1/6 & 1/4 & 1/6 & 1 & 1/6 & 1/2 & 1/5 \\ 3 & 1 & 3 & 1/2 & 6 & 1 & 5 & 3 \\ 1/4 & 1/6 & 1/4 & 1/5 & 2 & 1/5 & 1 & 1/3 \\ 3 & 1 & 3 & 1/2 & 5 & 1/3 & 3 & 1 \end{bmatrix} \tag{5.2}$$

A brief clarification about some of the adopted a_{jk} values in (5.2) is given here to further discuss the weighting process. It is assumed that the owner considers the reduction of the maintenance costs (C_2) moderately more important than the installation cost (C_1) because the former implies additional undesirable disruption of use; then, by adopting the linear scale in Table 3, it has to be assumed $a_{12} = 1/3$. The installation cost (C_1) is considered to be as important as the duration of works (C_3) since the latter results in a monetary loss (e.g. rent revenue) and therefore a_{13} was chosen equal to 1. The functional compatibility (C_4) is considered to be very important with respect to all other criteria ($a_{4k} \geq 1, k = 1, \dots, 8$). In fact, because of the residential destination of the structure and its moderate extension, the building results to be very sensitive to even the small architectural impact that an intervention may have on the normal use of the spaces.

The criterion concerning the significance of the needed intervention at foundation (C_6) is also assumed to be generally important ($a_{6k} \geq 1, k = 1, 2, 3, 5, \dots, 8$), since the corresponding evaluation should account for the additional time, cost and disruption to be sustained. For example, the DM strongly prefers that a retrofit technique requires a small intervention at the foundations even if it implies workers with a high degree of specialization

⁴The comparison of a criterion with itself obviously leads to a value a_{jj} equal to 1. Therefore, the DM has to carry out only $n(n-1)/2$ pairwise comparisons.

(criterion C_5); therefore, $a_{65} = 6$. On the other hand, criterion C_6 is judged to be only moderately more important than the installation cost, duration of works, and limited damage risk ($a_{61} = a_{63} = a_{68} = 3$), and it is assumed as important as maintenance costs ($a_{62} = 1$).

Criterion C_5 , regarding the skilled labor requirement and the technology level, is considered less important than the others ($a_{5k} \leq 1, k = 1, \dots, 8$), for the reasons above, that is, the owner prefers that the retrofit has better performance in terms of compatibility, costs, duration of works, even if the installation team has to be more specialized. Criterion C_7 (significant damage risk) is considered less relevant than C_8 (limited damage risk) since the design target of the alternatives was the SD limit state and it is satisfied by all solutions. Therefore, it is assumed that the owner is more interested in reducing the expected loss related to the repair in case of DL limit state occurrence; consequently, $a_{78} = 1/3$.

After all the pairwise comparisons have been performed and the \mathbf{A} matrix has been filled, a consistency measurement of the DM's judgments is needed, as will be discussed in the next section. If the comparisons among criteria are carried out in a perfectly consistent manner, each a_{jk} value is exactly equal to the ratio w_j/w_k between the weights of criteria C_j and C_k , respectively. In this ideal case, the \mathbf{A} matrix has rank equal to 1 and $\lambda = n = 8$ is its principal right eigenvalue. Moreover, it is also easy to show that the vector (\mathbf{W}) of relative weights w_1, w_2, \dots, w_8 is the principal right eigenvector.

In the more realistic case, a_{jk} deviates from the ratio w_j/w_k and the eigenvalues change consequently. In particular, the maximum eigenvalue λ_{\max} results to be greater than n (but close to it) while the other eigenvalues are close to zero. It is reasonable to assume the vector \mathbf{W} equal to the eigenvector that corresponds to λ_{\max} . In other words, \mathbf{W} has to satisfy the equation $\mathbf{A} \mathbf{W} = \lambda_{\max} \mathbf{W}$. In the case under examination, it results $\lambda_{\max} = 8.447$ and the vector \mathbf{W} results to be the following:

$$\mathbf{W}=\{w_i\} = \{0.073, 0.172, 0.073, 0.280, 0.026, 0.201, 0.035, 0.141\}. \tag{5.3}$$

Weights w_i can be used to rank the criteria with reference to their relative importance as shown in Table 4. Furthermore, the pie chart in Fig. 12 represents the shares of importance that the DM has defined via the pairwise comparisons. As anticipated previously, the weights have a significant influence on the final solution of the decisional problem and represent a subjective part of the procedure. For example, for the case under consideration, it results that the alternatives with the best evaluations in respect to criteria C_4 and C_6 (which are relatively the most important) will be favored, whereas the evaluations according to criteria C_5 and C_7 will play a less critical role in the final decision. Therefore special

TABLE 4 Ranking of criteria according to their weight

| Ranking order | Weights w_i | Criteria | Description |
|---------------|---------------|------------|--------------------------------------|
| I | 0.280 | C_4 | Functional compatibility |
| II | 0.201 | C_6 | Intervention at foundation |
| III | 0.172 | C_2 | Maintenance cost |
| IV | 0.141 | C_8 | Limited damage risk |
| V-VI | 0.073 | C_1, C_3 | Installation cost, Duration of works |
| VII | 0.035 | C_7 | Significant Damage risk |
| VIII | 0.026 | C_5 | Skilled labor requirement |

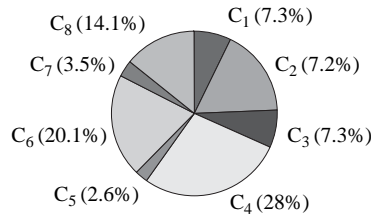

FIGURE 12 Shares of relative importance of criteria.

care is required in expressing the weighting judgements in a consistent manner, and in ensuring that the final solution is stable, i.e., it does not change for slight modifications of the weights' values.

5.1. Consistency Check of the Comparisons Among Criteria

A consistency measurement of the pairwise comparisons described may be useful to ensure that no intolerable conflicts exist and that the final decision is logically sound and not a result of random prioritization [Shapira and Goldenberg, 2005]. In case of a non successful check for consistency, the procedure aimed to draw up the **A** matrix has to be redone, in a more careful and coherent manner.

The pairwise comparisons can be considered conducted in a “perfectly” consistent way when the following condition is verified: if C_i is defined to be more important than C_j by a factor a_{ij} , and C_j is assumed to be more important than C_k by a factor a_{jk} , then C_i should be more important than C_k by the factor $a_{ik} = a_{ij} a_{jk}$. In this ideal case, in fact, it results $a_{ij} = w_i / w_j$ and $a_{jk} = w_j / w_k$; therefore, $a_{ik} = w_i / w_k = (w_i / w_j) (w_j / w_k) = a_{ij} a_{jk}$. Since the DM (adopting the Saaty's procedure described in the previous section) arbitrarily assigns a_{ij} values, without any mathematical constraint, they generally deviate from the w_i / w_j ratios, and the perfect consistency is not achieved. In these cases, a degree of consistency has to be evaluated and then compared with a limit value considered acceptable, depending on the number (n) of compared elements.

First of all, the so-called “Consistency Index” (CI) has to be calculated as follows:

$$CI = \frac{\lambda_{\max} - n}{n - 1}. \quad (5.4)$$

Then the CI has to be normalized by the “Random Consistency Index” (RCI) defined as an average random consistency measure depending on n (0, 0, 0.58, 0.90, 1.12, 1.24, 1.32, 1.41, 1.45 for $n = 1, 2, \dots, 9$, respectively). In this way, the so-called “Consistency Ratio” (CR) is obtained. In general, pairwise comparisons can be considered consistent enough if CR is less than 5% if $n = 3$, 9% if $n = 4$, 10% if $n > 4$. Otherwise, as mentioned, it is necessary to re-examine the pairwise judgements until acceptable consistency is achieved.

For the case under examination, since for $n = 8$ it is $RCI = 1.41$, the **A** matrix can be considered consistent enough since it results $CR = 4.5\% < 10\%$ as per Eq. (5.5);

$$CR = \frac{CI}{RCI} = \frac{\lambda_{\max} - n}{n - 1} \cdot \frac{1}{RCI} = \frac{8.447 - 8}{8 - 1} \cdot \frac{1}{1.41} = 4.5\%. \quad (5.5)$$

6. Evaluation of the Retrofit Alternatives

The sixth step of the decision making procedure consists of evaluating the alternative upgrading solutions in respect to the considered criteria.

C₁ – installation cost: The total cost to be sustained for the realization of each alternative⁵ include: all the materials and labor needed for the necessary demolitions (of structural and non structural elements); the realization of the “core” of each intervention; and the subsequent reconstruction of the non structural elements and finishings. Figure 13 reports the cost corresponding to these three categories, showing that the cost of the labour needed before and after the structural intervention properly defined, may be significant. The total values result to be 23,096 € for A₁, 53,979 € for A₂, 11,175 € for A₃, and 74,675 € for A₄.

C₂ – maintenance cost: Since the application of composite materials to structures is relatively recent, the durability and, consequently, the maintenance needs are still open issues. Given the not easy predictability of the necessary maintenance interventions during the economic life of the building (conventionally assumed to be 50 years), it is considered more realistic to compare the retrofit alternatives in terms of health’s monitoring cost to be sustained. For the alternative A₁ (GFRP), it is assumed that an instrumental inspection is needed every 10 years.

For the option A₂ (steel braces), an anticorrosive treatment it is considered necessary every 20 years, independently on the results of the periodic inspections to be performed every 5 years. The corresponding cost is then included into the evaluation of A₂ according to the criterion in exam.

For A₃ (RC jacketing), an inspection every 5 years and an instrumental examination every 10 years are considered.

For A₄ (base isolation), according to the instructions given by the HDRB devices’ producer, it is assumed that “normal” and “in-depth” inspections are alternatively required every 5 years (starting with an “in-depth” inspection right after the installation

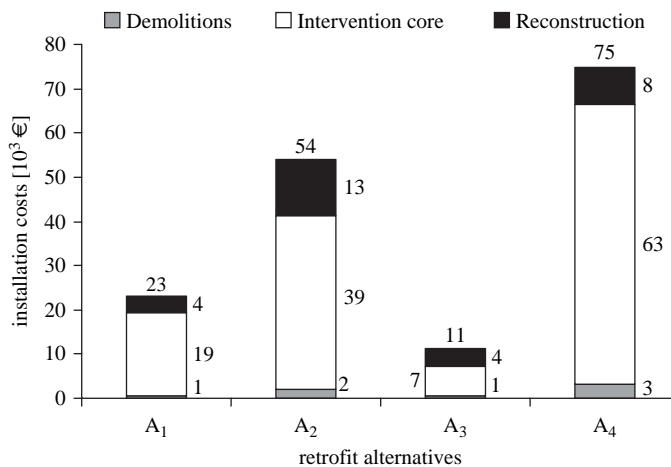

FIGURE 13 Installation cost: shares and total amount for each retrofit option.

⁵Excluding intervention at foundation; the same applies to criteria C₂ and C₃.

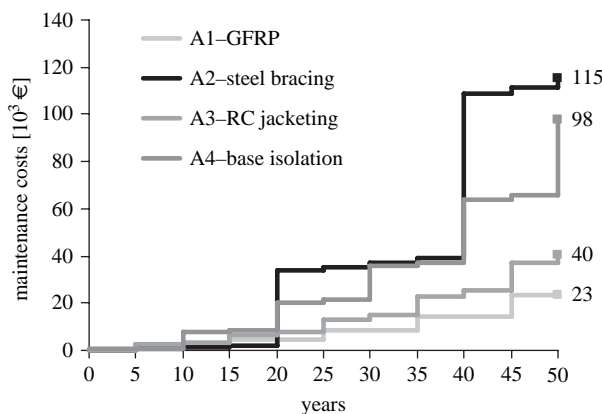

FIGURE 14 Maintenance costs during the economic life of the building, for each retrofit option.

of the isolation system). Moreover, the replacement of a single isolator unit every 10 years is considered, as suggested by the producers, in order to test it and assess the evolution of its mechanical properties.

Figure 14 shows the trend of the maintenance costs for each of the four options under examination. The total maintenance costs, accounting for a 4% revaluation rate, results in the following: 23,206 € (A_1); 115,037 € (A_2); 40,353 € (A_3); 97,884 € (A_4).

- C₃ – duration of works/disruption of use:** The time span needed to install each intervention is calculated by analyzing the time span required for each stage (beginning from the demolitions up to the finishings realization) and considering a team of four workmen (two of those are specialized workers). By assuming that each working day is composed by 8 hours, it results A_1 : 33 days; A_2 : 122 days; A_3 : 34 days; A_4 : 119 days.
- C₄ – functional compatibility** and **C₅ – skilled labor requirement:** The quantitative evaluations according to these qualitative criteria will be done apart (Sec. 6.2).
- C₆ – significance of the needed intervention at foundations:** In a rigorous approach, for each retrofit option, the assessment of the substructure should be performed. For practical reasons, a synthetic evaluation of alternatives according to C_6 is done instead. It consists in calculating a “global” parameter equal to the maximum ratio, measured for each column at the foundation level, between axial load due to the seismic action plus gravity loads and that due to the gravity loads only. It results A_1 : 2.90; A_2 : 15.18; A_3 : 2.97; A_4 : 2.65. As expected, the intervention with steel braces leads to a significant increase of the demand at foundation, due to the large nodal action transferred from the steel elements to the existing RC frame when the design earthquake is considered.
- C₇ – significant damage risk** and **C₈ – damage limitation risk:** The performances measurement with respect of these criteria will be done separately in the next sub-section in order to give the right space they need to be explained in an as much as possible complete manner.

6.1. Evaluation of Alternatives According to Criteria C_7 and C_8

Criteria C_7 (Significant Damage risk) and C_8 (Damage Limitation risk) are related to the seismic capacity of the building being defined as the ground motion intensity (measured by the peak ground acceleration, PGA) at which a certain limit state is attained. For

alternatives A_1 , A_2 , and A_3 , these capacity values are determined on the basis of the non-linear static analysis previously performed. The comparison among the corresponding pushover curves is shown in Fig. 15. It is worth noting that the un-retrofitted building's curves coincide with those relative to the building retrofitted by GFRP up to the vertical dashed lines indicating the attainment of the SD limit state by the original building. Therefore, retrofitting by GFRP leaves substantially unchanged the building capacity at DL limit state in comparison with that of the as-built structure.

The PGA of "failure" values at SD and DL limit states are then obtained by applying the N2 method [Fajfar, 2000] to the 12 pushover curves in Fig. 15. In its original form, the N2 method is used to determine the seismic demands given the earthquake intensity, but it can be adapted in order to determine intensity of the earthquake motion (PGA), given a target displacement of the structure [Stratan and Fajfar, 2003]. Briefly, this method allows the determination of the capacity in terms of PGA as the value that makes coincident the seismic capacity of the structure with the demand. In Fig. 16 it is reported, as an example, a graphical application of the N2 method aimed at determining the PGA capacity (0.43 g) at the SD limit state, for the +X direction, of the structure retrofitted by GFRP. The point D corresponds to the seismic demand imposed by the code for the zone 2 in which the building is located, C represents the seismic capacity and D' is the demand imposed by the

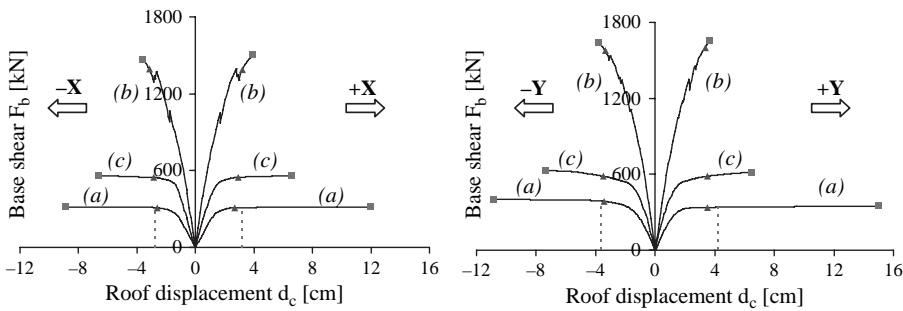

FIGURE 15 Pushover curves for the interventions A_1 (a), A_2 (b), and A_3 (c), along each direction ($\pm X$, $\pm Y$). Triangles and squares indicate the DL and SD limit states attainment, respectively.

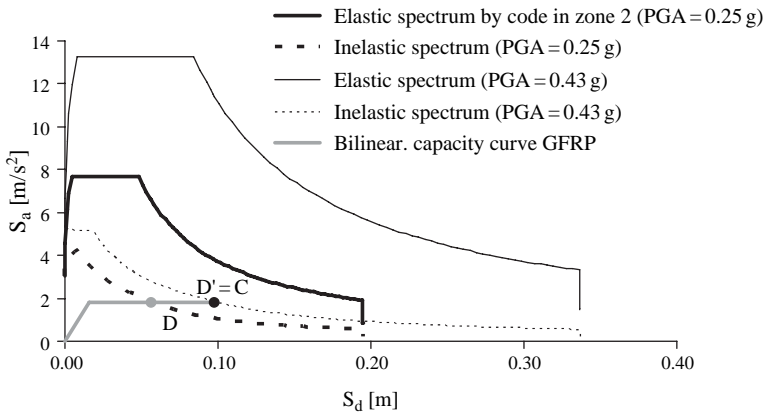

FIGURE 16 PGA capacity measurement according to the N2 method: example.

spectrum “anchored” to a PGA value equal to 0.43 g, determined by subsequent attempts, just in order to make C coincident with D’.

For the alternative A₄ (base isolation), the capacity at SD and DL limit states in terms of PGA is obtained by a modal response spectrum analysis. These limit conditions are attained in the isolator devices first and subsequently, for a larger value of the seismic demand, in the superstructure. Thus, the devices capacity substantially controls the global building seismic capacity when retrofit option A₄ is considered.

The following Table 5 summarizes the capacity values at SD and DL limit states (i.e., the minimum value among those corresponding to the four directions $\pm X$, $\pm Y$) for the original building and for the four considered retrofit alternatives.

The demand defined by the code for the site considered, measured in terms of PGA value on rock, is equal to 0.10 g and 0.25 g for the DL and SD limit states, respectively. Comparing these to Table 5, it is possible to conclude that all retrofit options achieve the structural performance targets of upgrading, since the capacity of the retrofitted building always results to be equal or larger than the demand for both limit states.

To evaluate the four alternatives in respect to criteria C₇ and C₈, the probability of exceeding in 50 years the capacity value PGA of Table 5 is computed. This is a proxy measure of the risk reduction implied by each retrofit solution. These probabilities (Table 6) are calculated by means of the hazard curve for Pomigliano d’Arco (Fig. 17), approximated by the relationship $p = 0.002\text{PGA}^{-2.18}$ (given by the Italian Seismic Survey, 2001).

C₇ – significant damage risk: The performance of each alternative according to this criterion is measured by the values at the SD row of Table 6.

C₈ – damage limitation risk: The evaluation of each of the four options in respect to this criterion, has to be interpreted as the probability of sustaining repair costs in 50 years rather than the probability of exceeding the capacity at DL limit state in 50 years. Therefore, the evaluation in respect to C₈ corresponds to the probability that the seismic capacity at the DL limit state is exceeded and at SD is not (otherwise it is unlikely to be convenient to repair the building) in 50 years. These values are calculated as the maximum difference (among all the four directions) between the probability of exceeding the DL and SD limit states, respectively. It results in A₁: 0.291; A₂: 0.002; A₃: 0.172; A₄: 0.000.

TABLE 5 Capacity values in terms of PGA [g] at Significant Damage (SD) and Damage Limitation (DL) limit states for as-built and retrofitted building

| Limit state | As built | A ₁ GFRP | A ₂ Steel bracing | A ₃ RC jacketing | A ₄ Base isolation |
|-------------|----------|------------------------|---------------------------------|--------------------------------|----------------------------------|
| SD | 0.103 | 0.332 | 0.317 | 0.253 | 0.348 |
| DL | 0.100 | 0.100 | 0.308 | 0.118 | 0.348 |

TABLE 6 Probability of exceeding in 50 years the seismic capacity at SD and DL limit states of the original and retrofitted building

| Limit state | As built | A ₁ GFRP | A ₂ Steel bracing | A ₃ RC jackets | A ₄ Base isolation |
|-------------|----------|------------------------|---------------------------------|------------------------------|----------------------------------|
| SD | 0.284 | 0.022 | 0.024 | 0.040 | 0.020 |
| DL | 0.303 | 0.303 | 0.026 | 0.211 | 0.020 |

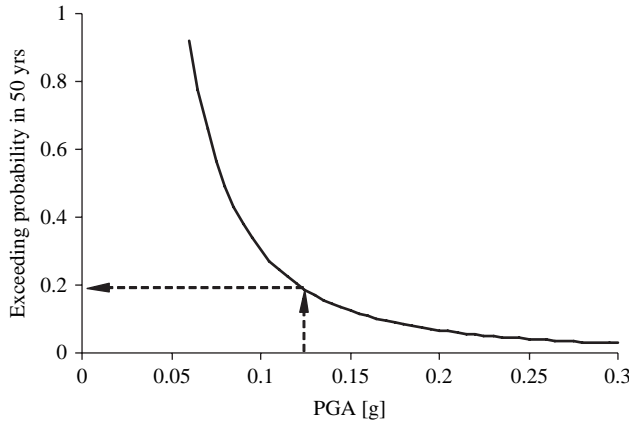

FIGURE 17 PGA on rock exceedance probability in 50 years (hazard curve) for Pomigliano d’Arco (Italy).

6.2. Quantitative Evaluation of Alternatives According to the Qualitative Criteria

In the presented application, only judgments in linguistic terms of retrofit alternatives according to criteria C_4 (functional compatibility) and C_5 (skilled labor requirement/ needed technology level) have been carried out. In order to apply any MCDM method (TOPSIS herein) the conversion of these qualitative variables into crisp numbers is needed. To complete this task, the eigenvalue approach is used, as done for the definition of criteria weights (Sec. 5). Therefore, pairwise comparisons among the alternatives were done in terms of their performances according to qualitative criteria C_4 and C_5 . Then, through the linear scale of Table 3, the a_{ij} crisp number, corresponding to the comparison between alternatives A_i and A_j was defined.⁶ After assembling two 4-by-4 matrices with all the a_{ij} values (Tables 7 and 8 for criteria C_4 and C_5 , respectively), the eigenvalue approach leads to the calculation of the quantitative performances of each retrofit option according to the considered qualitative criterion. A few comments are useful to understand how the procedure leads to the matrices of in Tables 7 and 8.

Criterion C_4 – functional compatibility: Alternative A_1 (GFRP) is much less invasive than A_2 (steel bracing) since the latter involves elimination of existing openings and windows of the braced bays (a significant fraction of bays, considering the relatively

TABLE 7 Quantitative evaluation of alternatives according to criterion C_4 ($\lambda_{max} = 4.042$; CR = 1.6%)

| | A_1 | A_2 | A_3 | A_4 | Priority |
|-------|-------|-------|-------|-------|----------|
| A_1 | 1 | 7 | 2 | 5 | 0.538 |
| A_2 | 1/7 | 1 | 1/3 | 1/2 | 0.074 |
| A_3 | 1/2 | 3 | 1 | 3 | 0.274 |
| A_4 | 1/5 | 2 | 1/3 | 1 | 0.114 |

⁶In Table 3 the relative “importance” has to be interpreted as the relative measure of the A_i and A_j alternatives’ fulfillment to the considered criterion.

TABLE 8 Quantitative evaluation of alternatives according to criterion C_5 ($\lambda_{\max} = 4.037$; CR = 1.4%)

| | A ₁ | A ₂ | A ₃ | A ₄ | Priority |
|----------------|----------------|----------------|----------------|----------------|----------|
| A ₁ | 1 | 4 | 7 | 1 | 0.414 |
| A ₂ | 1/4 | 1 | 3 | 1/4 | 0.120 |
| A ₃ | 1/7 | 1/3 | 1 | 1/7 | 0.052 |
| A ₄ | 1 | 4 | 7 | 1 | 0.414 |

small size of the building). The GFRP intervention (the superimposed plastic fabric layers are less than 1 mm in thickness) practically does not imply any impact on the architectural configuration and functionality of the original structure. Concrete jacketing of the three selected columns (A₃) involves only a small enlargement of the cross sections that may result in a moderately unpleasant appearance of the facades. Base isolation does not imply any intervention on the superstructure, although it results in a use restriction of the building at ground floor since the removal of the existing floor and the laying of removable steel grilles (necessary for the maintenance of isolators).

Criterion C₅ – skilled labor requirement/needed technology level: The installation of the retrofit alternatives A₁ (GFRP) and A₄ (base isolation) requires a relatively high level of workers' specialization, moderately higher in comparison with option A₂ (steel bracing), strongly in respect to A₃ (concrete jacketing).

From Tables 7 and 8 it is possible to compute the Consistency Ratios (like in the Equation (5.5)): 1.6% for C₄ and 1.4% for C₅. They are both much lower than the limit of 9% given by Saaty [1999] for a 4-by-4 matrix, indicating a satisfactory degree of consistency of the pairwise comparisons made above.

7. Ranking of the Alternatives and Selection of the Best Retrofit Solution

The selected MCDM method is the Technique for Order Preference by Similarity to Ideal Solution (TOPSIS). It was developed by Hwang and Yoon [1981] and is based on the geometrical concept that the best alternative should have the shortest distance to an *ideal* solution (A*) and the farthest distance to a *negative-ideal* one (A⁻).

Let x_{ij} indicate the performance measure of the i -th alternative ($i = 1, 2, 3, 4$) in terms of the j -th criterion ($j = 1, 2, \dots, 8$), evaluated in the previous sections. All the x_{ij} have to be collected in the decision matrix $\mathbf{D} = [x_{ij}]$ representing the starting point for any application of the TOPSIS method (Table 9). The normalization of x_{ij} values, each of those being characterized by different units, has to be done. According to the TOPSIS procedure, Eq. (7.1) is adopted to do this. Let r_{ij} indicate the normalized value of x_{ij} . The normalized

TABLE 9 Decision Matrix \mathbf{D}

| | C ₁ [€] | C ₂ [€] | C ₃ [days] | C ₄ | C ₅ | C ₆ | C ₇ | C ₈ |
|----------------|--------------------|--------------------|-----------------------|----------------|----------------|----------------|----------------|----------------|
| A ₁ | 23,096 | 23,206 | 33 | 0.538 | 0.414 | 2.90 | 0.022 | 0.291 |
| A ₂ | 53,979 | 115,037 | 122 | 0.074 | 0.120 | 15.18 | 0.024 | 0.002 |
| A ₃ | 11,175 | 40,353 | 34 | 0.274 | 0.052 | 2.97 | 0.040 | 0.172 |
| A ₄ | 74,675 | 97,884 | 119 | 0.114 | 0.414 | 2.65 | 0.020 | 0.000 |

decision matrix $\mathbf{R} = [r_{ij}]$ is thus obtained (Table 10). The next step is weighting the \mathbf{R} matrix by multiplying each value of the j -th column by the weight (w_j) of the j -th criterion. This leads to obtain the weighted normalized decision matrix, $\mathbf{V} = [w_j r_{ij} = v_{ij}]$, given in Table 11.

$$r_{ij} = \frac{x_{ij}}{\sqrt{\sum_{k=1}^4 x_{kj}^2}} \tag{7.1}$$

The two opposite fictitious solutions A^* and A^- , exactly as for the real alternatives A_1, A_2, A_3 , and A_4 , are defined by eight values, representing the performances (weighted and normalized) measured according the criteria (Table 12). In particular, the ideal solution A^* is obtained by taking for each criterion the “best” performance value among A_1, A_2, A_3 , and A_4 (indicated by an asterisk in Fig. 18). Conversely, the negative-ideal solution A^- is composed by considering for each criterion the “worst” performance measure among the alternatives (indicated by a minus in Fig. 18).

It is important to remark that the best value among performances of all the alternatives in respect of the generic criterion C_i has to be interpreted as the minimum value among those included in the i -th column of the \mathbf{V} matrix if C_i is a “cost” criterion (that is a criterion in respect of which the DM is interested in minimizing the performance value of the intervention). On the other hand, the best value is assumed as the maximum value if C_i is a “benefit” criterion (like C_4 , that is the only benefit criterion among the considered

TABLE 10 Normalized Decision Matrix \mathbf{R}

| | C_1 | C_2 | C_3 | C_4 | C_5 | C_6 | C_7 | C_8 |
|-------|-------|-------|-------|-------|-------|-------|-------|-------|
| A_1 | 0.241 | 0.147 | 0.187 | 0.869 | 0.690 | 0.182 | 0.398 | 0.861 |
| A_2 | 0.564 | 0.728 | 0.690 | 0.120 | 0.200 | 0.951 | 0.434 | 0.006 |
| A_3 | 0.117 | 0.255 | 0.192 | 0.443 | 0.087 | 0.186 | 0.723 | 0.509 |
| A_4 | 0.781 | 0.619 | 0.673 | 0.184 | 0.690 | 0.166 | 0.362 | 0.000 |

TABLE 11 Weighted Normalized Decision Matrix \mathbf{V}

| | C_1 | C_2 | C_3 | C_4 | C_5 | C_6 | C_7 | C_8 |
|-------|-------|-------|-------|-------|-------|-------|-------|-------|
| A_1 | 0.018 | 0.025 | 0.014 | 0.243 | 0.018 | 0.037 | 0.014 | 0.121 |
| A_2 | 0.041 | 0.125 | 0.050 | 0.033 | 0.005 | 0.191 | 0.015 | 0.001 |
| A_3 | 0.009 | 0.044 | 0.014 | 0.124 | 0.002 | 0.037 | 0.025 | 0.072 |
| A_4 | 0.057 | 0.107 | 0.049 | 0.052 | 0.018 | 0.033 | 0.013 | 0.000 |

TABLE 12 Ideal solution A^* and negative-ideal solution A^-

| | C_1 | C_2 | C_3 | C_4 | C_5 | C_6 | C_7 | C_8 |
|-------|-------|-------|-------|-------|-------|-------|-------|-------|
| A^* | 0.009 | 0.025 | 0.014 | 0.243 | 0.002 | 0.033 | 0.013 | 0.000 |
| A^- | 0.057 | 0.125 | 0.050 | 0.033 | 0.018 | 0.191 | 0.025 | 0.121 |

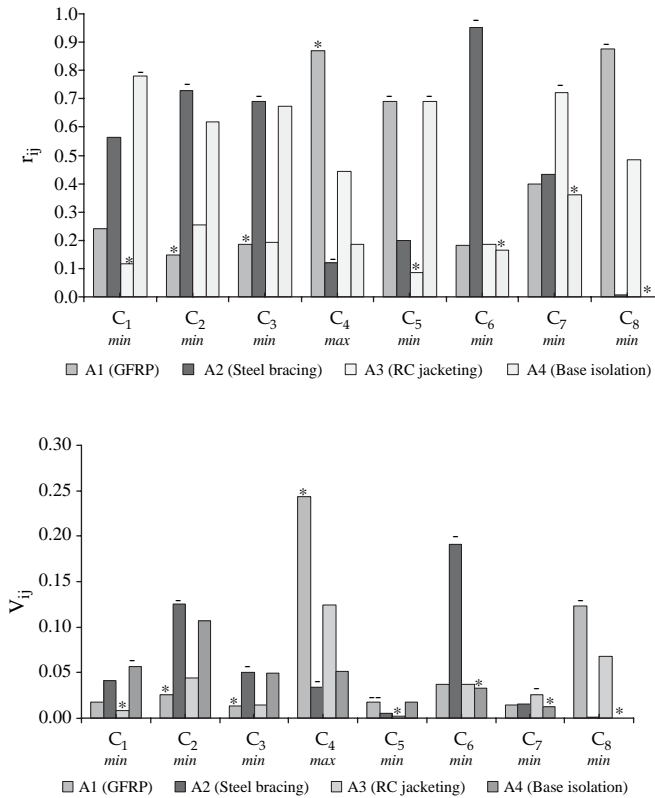

FIGURE 18 Graphical comparison among alternatives in terms of normalized performances r_{ij} (top) and weighted normalized performances v_{ij} (bottom)

criteria: actually the DM is interested in maximizing the compatibility of the retrofit intervention to the existing building).

A comparison among the alternatives in terms of normalized performances r_{ij} is shown by the bar diagram in the top panel of Fig. 18 where it is also indicated, for each criterion, if the Decision Maker’s goal is to maximize or minimize the corresponding performance score. The bar chart in the lower part of Fig. 18 shows, instead, the comparison done with reference to the weighted normalized values $v_{ij} = w_j r_{ij}$. The transformation of the first diagram into the second one, depending on the value of criteria weights, reflects the Decision Maker profile and the building’s destination of use.

Each of the alternatives, real (A_1, A_2, A_3, A_4) and fictitious (A^* and A^-), can be thought of as a point of the 8th dimensional space defined by the axes along which performances according to each of the 8 criteria are measured. Therefore, each row of the \mathbf{V} matrix (Table 11) gives the coordinates of such points. The coordinates for the ideal options are defined by the values in Table 12. Figure 19 reports, as an example, a 3D portion (axis C_4, C_6, C_8) of the criteria space, in order to show the reciprocal position of the alternatives and their distances the A^* and A^- alternatives.

Let S_{i^*} and S_{i^-} indicate the distance of A_i to A^* and A^- , respectively, see Eq. (7.2). The TOPSIS method ranks alternative solutions in terms of the so-called *relative closeness*

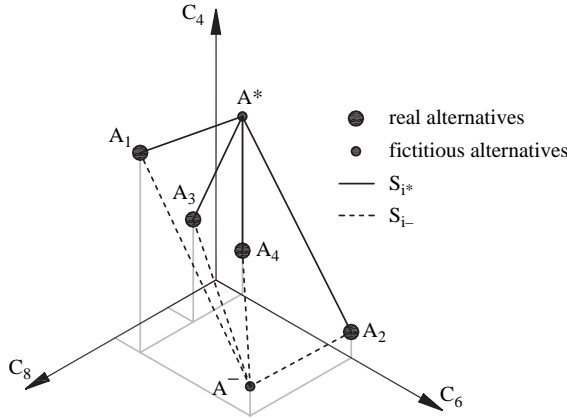

FIGURE 19 A 3D portion of the 8D criteria space: alternatives and distances representation.

C_{i^*} ($0 \leq C_{i^*} \leq 1$) to the A^* , with C_{i^*} defined as in the Eq. (7.3). The best alternative is the one with the highest C_{i^*} value.⁷

$$S_{i^*} = \sqrt{\sum_{j=1}^8 (\nu_{ij} - \nu_{j^*})^2} ; S_{i^-} = \sqrt{\sum_{j=1}^8 (\nu_{ij} - \nu_{j^-})^2} ; i = 1, 2, 3, 4. \tag{7.2}$$

$$C_{i^*} = \frac{S_{i^-}}{S_{i^*} + S_{i^-}}. \tag{7.3}$$

The obtained S_{i^*} , S_{i^-} , and C_{i^*} values for the four alternatives under examination are reported in Table 13. Alternative A_1 (GFRP) results to be the best one, with a relative closeness, C_{i^*} , equal to 0.70. Alternative A_1 also results to have the shortest absolute distance from the ideal solution A^* ($S_{i^*} = 0.123$) and the farthest absolute distance from the negative-ideal solution A^- ($S_{i^-} = 0.285$). A_3 (concrete jackets), A_4 (base isolation), and A_2 (steel bracing) follow.

TABLE 13 Distances S_{i^*} , S_{i^-} and relative closeness to the ideal solution C_{i^*} of each alternative

| Alternative | | S_{i^*} | S_{i^-} | C_{i^*} |
|------------------|-------|-----------|-----------|-----------|
| GFRP | A_1 | 0.123 | 0.285 | 0.70 |
| Steel bracing | A_2 | 0.285 | 0.123 | 0.30 |
| Concrete jackets | A_3 | 0.141 | 0.212 | 0.60 |
| Base isolation | A_4 | 0.217 | 0.201 | 0.48 |

⁷Clearly it results $C_{i^*} = 1$ if $A_i = A^*$ and $C_{i^*} = 0$ if $A_i = A^-$.

8. Sensitivity Analysis

A sensitivity analysis may be useful to assess the stability of the optimal solution under changes in the input parameters (i.e., criteria weights w_i and alternatives' evaluations x_{ij}). In particular, the sensitivity of the assigned weights (according to Triantaphyllou, 2002) is reported here, not covering changes in the x_{ij} values (that would result in $4 \times 8 = 32$ different sensitivity scenarios).

The first step is done by taking one decision criterion at a time and determining the intervals (included between 0 and 1) in which its weight value may vary without affecting the ranking of the alternatives. These intervals, together with the corresponding alternatives' classification, are shown in the Table 14. It is worth noting that criteria C_2 , C_3 , and C_6 can be defined as robust criteria since any arbitrary change in their weight does not affect the existing ranking of any of the alternatives.

In order to measure the sensitivity of each weight to the final decision, absolute or relative (namely divided by the adopted w_i value) changes of their values can be considered. Furthermore, it is interesting to see whether a change in the current weight value causes any two alternatives to reverse their existing ranking or only the change of the best alternative. Thus, four different sensitivity definitions can be considered. Herein the Percent-Top (PT) definition [Triantaphyllou, 2002] is considered, since it is appropriate to survey the best solution changes. In Table 15 the minimum absolute change (indicated as "AT," Absolute-Top) causing the variation of the best solution (starting from the selected one, A_1) is reported for each weight. The corresponding relative PT change is then

TABLE 14 Sensitivity analysis for criteria weights

| Weights | Assumed values | Intervals | Ranking order | | | |
|---------|----------------|---------------|---------------|-------|-------|-------|
| | | | I | II | III | IV |
| w_1 | 0.073 | 0.000 ÷ 0.499 | A_1 | A_3 | A_4 | A_2 |
| | | 0.499 ÷ 0.583 | A_3 | A_1 | A_4 | A_2 |
| | | 0.583 ÷ 1.000 | A_3 | A_1 | A_2 | A_4 |
| w_2 | 0.172 | 0.000 ÷ 1.000 | A_1 | A_3 | A_4 | A_2 |
| w_3 | 0.073 | 0.000 ÷ 1.000 | A_1 | A_3 | A_4 | A_2 |
| w_4 | 0.280 | 0.000 ÷ 0.097 | A_3 | A_4 | A_1 | A_2 |
| | | 0.097 ÷ 0.183 | A_3 | A_1 | A_4 | A_2 |
| | | 0.183 ÷ 1.000 | A_1 | A_3 | A_4 | A_2 |
| w_5 | 0.026 | 0.000 ÷ 0.183 | A_1 | A_3 | A_4 | A_2 |
| | | 0.183 ÷ 0.321 | A_3 | A_1 | A_4 | A_2 |
| | | 0.321 ÷ 0.477 | A_3 | A_1 | A_2 | A_4 |
| | | 0.477 ÷ 1.000 | A_3 | A_2 | A_1 | A_4 |
| w_6 | 0.201 | 0.000 ÷ 1.000 | A_1 | A_3 | A_4 | A_2 |
| w_7 | 0.035 | 0.000 ÷ 0.365 | A_1 | A_3 | A_4 | A_2 |
| | | 0.365 ÷ 0.651 | A_1 | A_4 | A_3 | A_2 |
| | | 0.651 ÷ 1.000 | A_1 | A_4 | A_2 | A_3 |
| w_8 | 0.141 | 0.000 ÷ 0.241 | A_1 | A_3 | A_4 | A_2 |
| | | 0.241 ÷ 0.255 | A_3 | A_1 | A_4 | A_2 |
| | | 0.255 ÷ 0.267 | A_3 | A_4 | A_1 | A_2 |
| | | 0.267 ÷ 0.325 | A_4 | A_3 | A_1 | A_2 |
| | | 0.325 ÷ 0.377 | A_4 | A_3 | A_2 | A_1 |
| | | 0.377 ÷ 1.000 | A_4 | A_2 | A_3 | A_1 |

TABLE 15 Absolute-Top (AT), Percent-Top (PT) changes, and sensitivity of criteria weights

| Weights | Assumed values | AT | PT (%) | Sensitivity |
|---------|----------------|-------|--------|-------------|
| w_1 | 0.073 | 0.425 | 582 | 0.00172 |
| w_2 | 0.172 | N.F. | N.F. | 0 |
| w_3 | 0.073 | N.F. | N.F. | 0 |
| w_4 | 0.280 | 0.098 | 35 | 0.02857 |
| w_5 | 0.026 | 0.156 | 600 | 0.00167 |
| w_6 | 0.201 | N.F. | N.F. | 0 |
| w_7 | 0.035 | N.F. | N.F. | 0 |
| w_8 | 0.141 | 0.099 | 70 | 0.01424 |

obtained by dividing the AT value by the weight w_i of criterion C_i . The PT value for C_i can also be defined as “criticality degree” of the i -th criterion. The sensitivity coefficient of the C_i criterion is the reciprocal of its criticality degree. For the robust criteria, AT and PT values are non feasible (N.F. in the Table 15) and the sensitivity coefficient is set to be equal to zero.

Criterion C_4 (functional compatibility) results to be the PT “critical criterion” since it has the minimum PT value (35%) and consequently the maximum sensitivity coefficient (0.0029). In fact, it frequently happens that when weight changes are measured in relative terms, the most sensitive decision criterion is the one with the highest weight ($w_4 = 0.280$).

Six of the eight criteria weights may assume very large changes in their values without determining a best solution different from A_1 . Only criteria C_4 and C_8 seem to be more sensitive to the optimal alternative, but their PT changes (35 and 70%, respectively) are judged to be large enough to say sufficiently stable the selected optimal retrofit solution.

9. Conclusions

The choice of the technique to implement a retrofit strategy in a seismic upgrading project involves several non homogeneous variables and different objectives, which may require a formal approach for the determination of the optimum. In fact, conversely to what may be expected, often the most relevant criteria for the decision in a seismic upgrading problem are not those related to structural performance or, at least, they should be considered together with others non technical and/or non quantitative. The study presented aimed at exploring a rational and quantitative approach to evaluate and rank different solutions for the seismic retrofit of existing RC structures. As a multi-criteria decision issue, it was tackled herein by a method allowing to quantitatively uniform the relevant scores of any of the alternatives in the pre-defined set, in a way they can be combined in a measure of the relative distance to the “best” and “worst” cases, made of *virtual* solutions.

The MCDM has some critical aspects in the procedure which, more than others, affect the final ranking and the identification of the best intervention. In particular, the choice of the relevant criteria reflects the decision-maker/stake-holder profile. Similarly, the definition of the weight for each criterion represents a subjective step. Also, the conversion of the qualitative evaluations into crisp numbers may be non trivial and may require a careful application of non traditional approaches. Therefore, tools as the consistency index and the sensitivity analysis are useful to control and disaggregate the decision process.

These points have been discussed with reference to an illustrative example referring to a substandard RC structure representing existing buildings, lacking appropriate seismic

features, in southern Europe. A set of solutions spanning a wide range of possible retrofit strategies have been considered. The hypothetical interventions designed have as objectives the improvement of the deformation capacity and/or the enhancement of the strength, or the isolation of the building to control the seismic response.

For the investigated case, results indicate the confinement of elements by FRP as the final choice. In fact, the low architectural impact on the building and the good score in respect to an eventually required foundation upgrading, determined the rank. The sensitivity analysis consistently shows a fairly stable result in respect to the *critical* and *robust* criteria. Similarly, but with opposite consequences, the steel bracing, as expected, results as an unsuitable retrofit solution for such small residential building. How the final ranking reflects the chosen criteria and their weights in the decision may also be argued considering that if the limited damage limit state would be a relevant criterion, the ranking of the solutions would change.

Acknowledgments

Authors would like to thank Mrs. Racquel K. Hagen for proofreading the article.

References

- ATC-40 [1996] Applied Technology Council, Seismic evaluation and retrofit of concrete buildings. Report No. ATC-40, Redwood City, California.
- CNR-DT 200 [2004] Istruzioni per la Progettazione, l'Esecuzione ed il Controllo di Interventi di Consolidamento Statico mediante l'utilizzo di Compositi Fibrorinforzati. Materiali, strutture in c.a. e in c.a.p., strutture murarie, Versione sottoposta ad inchiesta pubblica, Rome, Italy.
- Caterino, N. [2006] "Analisi decisionale multicriterio per l'adeguamento sismico di edifici in c.a.," Ph.D. thesis, Univ. of Naples Federico II, www.dist.unina.it/doc/tesidott/PhD2006.Caterino.pdf. (In Italian)
- Cosenza, E., Di Ludovico, M., Manfredi, G., and Prota, A. [2005] "Design of the FRP retrofit of the SPEAR structure," *Proceedings of the SPEAR International Workshop* (Fardis, M. and Negro, P. Eds.), Ispra, Varese, Italy.
- C.S.I., Computers and Structures Inc., SAP 2000NL, v 8.2.3. [2004]. Static and Dynamic Finite Element Analysis of Structures, Berkeley, CA.
- Fajfar, P. [2000] "A non linear analysis method for performance-based seismic design," *Earthquake Spectra* **16**(3), 573–92.
- Fardis, M. N. and Negro, P. [2005] "Seismic Performance Assessment and Rehabilitation of Existing Buildings," *Proceedings of the SPEAR International Workshop*, Ispra, Varese, Italy.
- Fardis, M. N. [1994] "Analysis and design of reinforced concrete buildings according to Eurocode 2 and 8," *Reports on Prenormative Research in Support of Eurocode 8*.
- Fib bulletin No. 24 [2003] Seismic assessment and retrofit of reinforced concrete buildings.
- Hwang, C. L. and Yoon, K. [1981] "Multiple Attribute Decision Making," *Lecture Notes in Economics and Mathematical Systems 186*, Springer-Verlag, Berlin.
- Italian Seismic Survey [2001] Seismic Hazard for the Italian Territory (CD-ROM), Rome, Italy (in Italian).
- Jeong, S.-H. and Elnashai, A. S. [2005] "Analytical Assessment of an Irregular RC Frame for Full-Scale 3D Pseudo-Dynamic Testing-Part I: Analytical Model Verification," *Journal of Earthquake Engineering*, **9**(1), 95–128.
- Mander, J. B., Priestley, M. J. N., and Park, R. [1988] "Theoretical stress-strain model for confined concrete," *ASCE Journal of Structural Engineering*, **114**(8), 1804–1826.
- NEAK [1995] Greek Code for Earthquake Resistant Design, Athens, Greece.
- NKOS [1995] Greek Code for Reinforced Concrete Design, Athens, Greece.

- OPCM 3274 [2003] Ordinanza del Presidente del Consiglio dei Ministri, Primi elementi in materia di criteri generali per la classificazione sismica del territorio nazionale e normative tecniche per le costruzioni in zona sismica, Rome, Italy.
- OPCM 3431 [2005] Ordinanza del Presidente del Consiglio dei Ministri, Ultime modifiche ed integrazioni all'Ordinanza n. 3274 del 20 marzo 2003, Rome, Italy.
- Saaty, T. L. [1980] *The Analytic Hierarchy Process* McGraw-Hill, New York.
- Saaty T. L. [1999] *Decision Making for Leaders: The Analytic Hierarchy Process for Decision in a Complex World*, RWS Publications, Pittsburgh, PA.
- Shapira, M. and Goldenberg, M. [2005] "AHP-based equipment selection model for construction projects," *ASCE Journal of Construction Engineering and Management*, **131**(12), 1263–1273.
- Spolstra, M. R. and Monti, G. [1999] "FRP-confined concrete model," *ASCE Journal of Composites for Construction*, **3**(3), 143–150.
- Stratan, A. and Fajfar, P. [2003] "Seismic Assessment of the SPEAR Test Structure," University of Ljubljana, www.ikpir.com/projects/spear/.
- Thermou, G. E. and Elnashai, A. S. [2002] Report about SPEAR Project, Performance Parameters and Criteria for Assessment and Rehabilitation, A.S., I.C. of Science, Technology and Medicine, UK, 2002.
- Triantaphyllou, E. [2002] "Multi-criteria decision making methods: a comparative study," *Applied Optimization*, Vol. 44, Kluwer Academic Publishers, Dordrecht, The Netherlands.