

## MULTIBAND CPW-FED TRIANGLE-SHAPED MONOPOLE ANTENNA FOR WIRELESS APPLICATIONS

Y. Song, Y.-C. Jiao, G. Zhao, and F.-S. Zhang

National Laboratory of Antennas and Microwave Technology  
Xidian University  
Xi'an, Shaanxi 710071, P. R. China

**Abstract**—A multiband CPW-fed triangle-shaped monopole antenna for wireless applications covering 2.4- and 5 GHz WLAN bands and 3.4 GHz WIMAX band in IEEE 802.16 is proposed. Prototype of the proposed antenna have been constructed and tested. The experimental results show that the antenna can provide two separate impedance bandwidths of 140 MHz (about 5.8% centered at 2.43 GHz) and 3100 MHz (about 61.4% centered at 4.91 GHz), which meet the required bandwidths specification of 2.4/5 GHz WLAN and 3.4 GHz WIMAX standard. Good omnidirectional radiation in the desired frequency bands has been achieved. The proposed antenna with relatively low profile is suitable for multiband wireless applications.

### 1. INTRODUCTION

Recently, wireless communications have been developed widely and rapidly, which leads to a great demand in designing low-profile, and multiband antennas for mobile terminals [7, 8]. Many antennas, such as the CPW-fed antennas and slot-loaded monopole antennas, with dual-band characteristics for wireless applications have been reported [3–6]. However, there is a limit of these antennas to obtain the wideband characteristic especially at 5 GHz band for both WLAN and WIMAX applications operating simultaneously at 5.2, 5.8 and 3.5 GHz, respectively [3, 4].

In this paper, we propose a novel multiband CPW-fed triangle-shaped planar antenna covering the operating bands of both WLAN in IEEE 802.11 b/a/g at 2.4 GHz (2400–2484 MHz), 5.2 GHz (5150–5350 MHz) and 5.8 GHz (5725–5825 MHz) and Worldwide Interoperability for Microwave Access (WIMAX) based on IEEE

802.16 at 3.4 GHz (3400–3600 MHz). The proposed antenna was simulated using Ansoft High Frequency Structure Simulator (HFSS), and the prototype of the antenna was constructed and tested. By adjusting the dimensions of the stubs in the patch, broad impedance bandwidth and good radiation characteristics suitable for WLAN and WIMAX can be achieved in the upper frequency band. Details of the antenna design and the experimental results are presented and discussed.

## 2. ANTENNA DESIGN

Fig. 1 shows the geometry of the proposed triangle-shaped planar antenna for multiband operation. The antenna is symmetrical with respect to the longitudinal direction. The dimensions of the antenna included the feed structure are  $35 \times 24 \text{ mm}^2$  designed for both WLAN and WIMAX, on a substrate of thickness of 1.6 mm and the dielectric constant of the inexpensive FR4 substrate is  $\epsilon_r = 4.4$ . A  $50\Omega$  CPW transmission line, which consists of a signal strip width of 2 mm and a gap distance of 0.25 mm between the single strip and the coplanar ground plane, is used for feeding the antenna. The basis of the radiating element of the antenna is a modified triangle-shaped patch monopole, which has the dimensions shown in the Fig. 1(c), and is connected at the end of the CPW feed line with a spacing of 1.2 mm from the edge of the ground plane. The modified ground plane is used to achieve broad bandwidth. It should be noted that the cross-shaped strip within the top of the patch and another strips around the ground, denoted as  $S_1$  and  $S_2$ , will affect on the impedance matching of the proposed antenna, the influence will also be discussed in the following section. The major effect of the inserted triangular slit in the patch is to produce another current path operating at 5-GHz band, and thus a new resonant frequency is excited. In this geometry of the prototype antenna on the  $z$ -axis symmetry, the resonant path length (B-C-D-E) is set 30.8 mm close to  $0.25\lambda$  at 2.44 GHz, the slot length (I-C-D-E-F) is about 26.6 mm corresponding to  $0.33\lambda$  at 3.7 GHz, and the slit dimension (A-B-G-H) is 15.5 mm which approximates  $0.29\lambda$  at 5.7 GHz. The photograph of the antenna is shown in Fig. 2.

## 3. RESULTS AND DISCUSSION

A prototype based on the design was fabricated and measured with WILTRON-37269A Vector Network Analyzer. The measured and simulated return losses of the antenna are shown in Fig. 3. It is clearly seen that the lower frequency band is about 140 MHz from 2.36 to

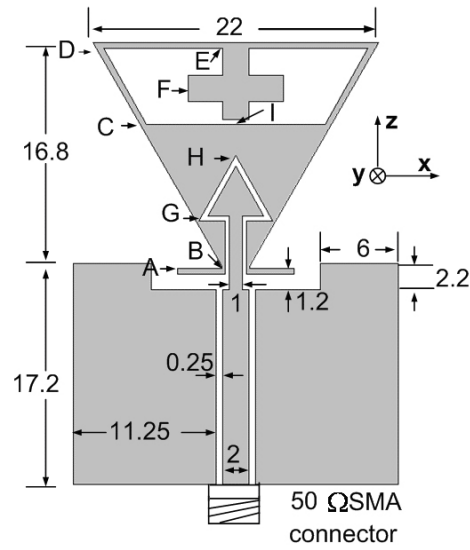

(a) units [mm]



(b)

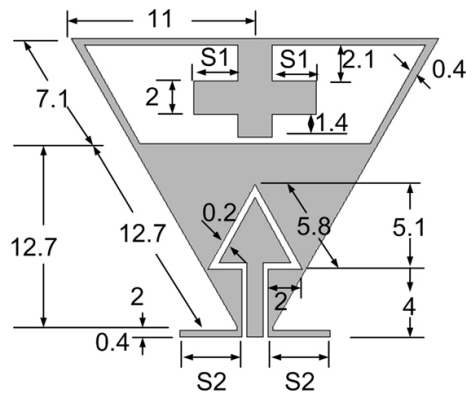

(c)

**Figure 1.** Geometry and dimensions of proposed antenna: (a) Top view; (b) Side view; (c) Detailed dimensions of the radiation element.

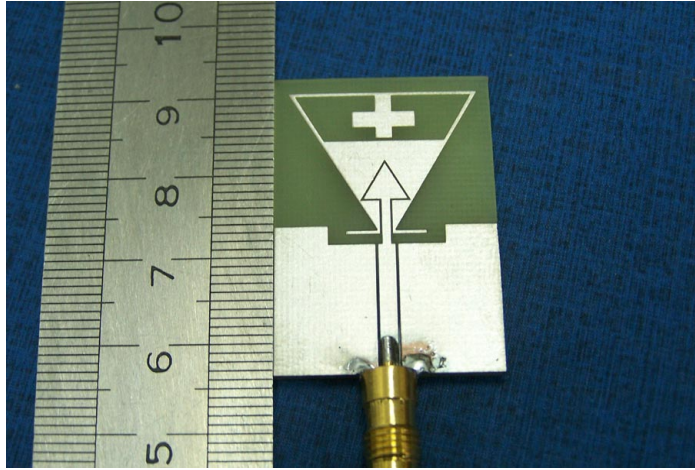

**Figure 2.** Photograph of proposed antenna with  $S_1 = 2.6$  mm and  $S_2 = 3.0$  mm.

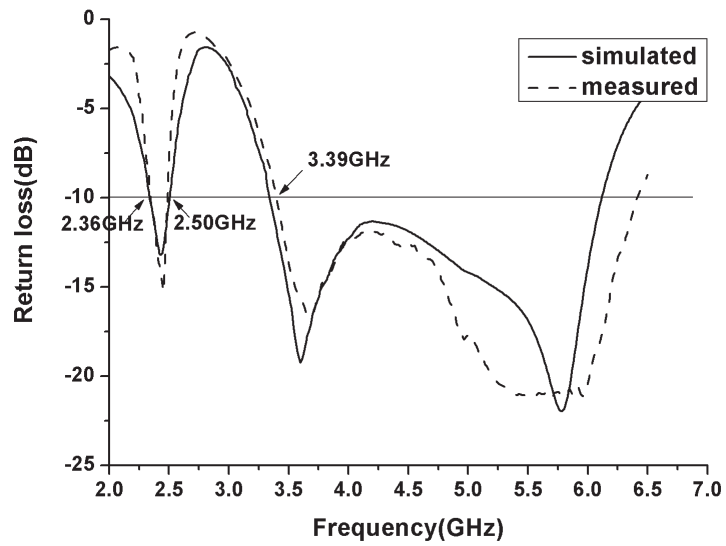

**Figure 3.** Measured and simulated return loss against frequency for proposed antenna with  $S_1 = 2.6$  mm and  $S_2 = 3.0$  mm.

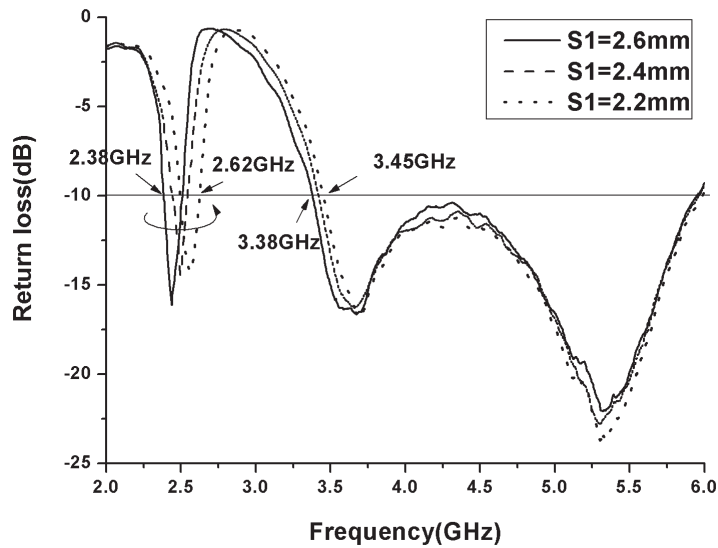

**Figure 4.** Measured return loss against frequency for proposed antenna with various length  $S_1$ ,  $S_2 = 3.7$  mm (other parameters are the same as in Fig. 1).

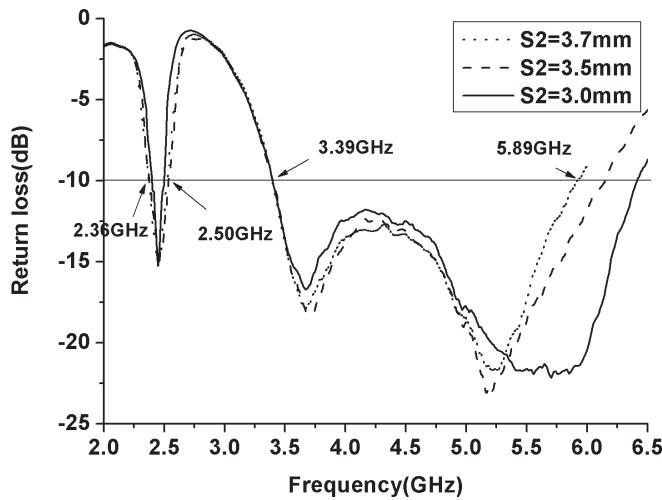

**Figure 5.** Measured return loss against frequency for proposed antenna with various length  $S_2$ ,  $S_1 = 2.6$  mm (other parameters are the same as in Fig. 1).

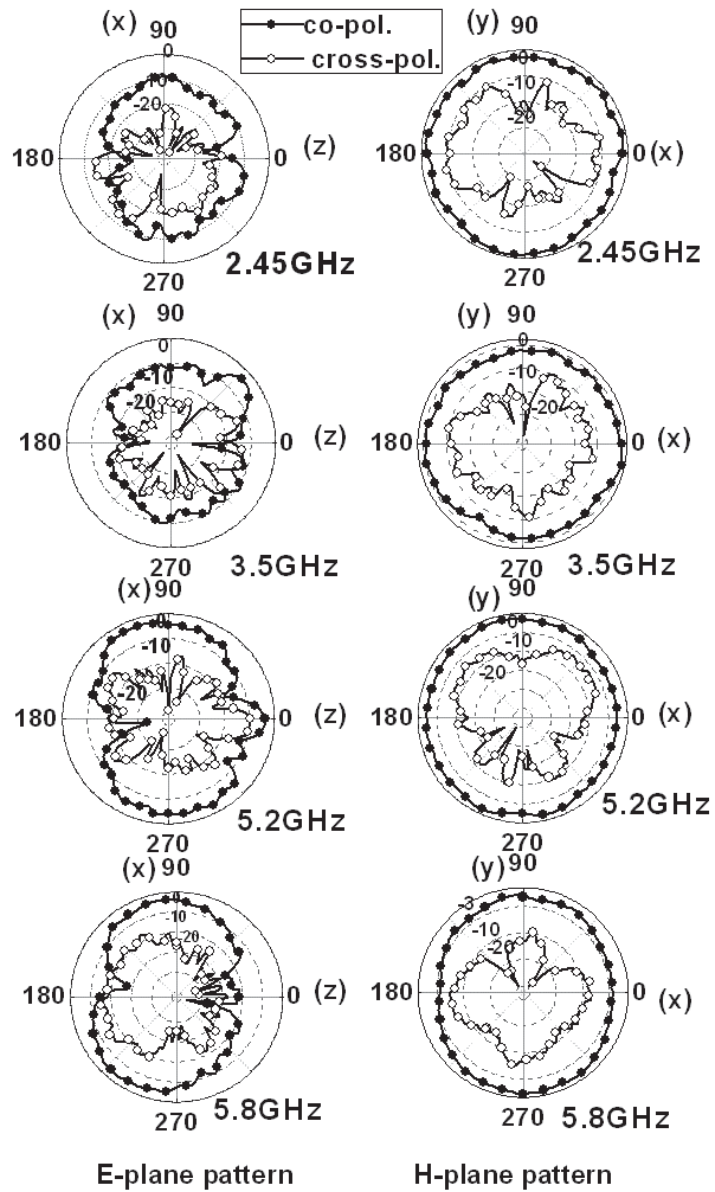

**Figure 6.** Measured radiation patterns for proposed antenna with  $S_1 = 2.6$  mm and  $S_2 = 3.0$  mm.

2.50 GHz for  $S_{11} < -10$  dB, which meets the bandwidth requirement for 2.4 GHz WLAN operation. As for the higher frequency band, the broad bandwidth obtained is 3100 MHz (3.40–6.41 GHz), or 61.4% with respect to the center frequency of 4.91 GHz, which is formed by two resonating modes close to each other and covers both the 5 GHz WLAN bands and the 3.4 GHz WIMAX band in IEEE 802.16. Fig. 4 shows the tuning effect of varying the stub length as  $S_1 = 2.6, 2.4$  and 2.2 mm with a fixed  $S_2$  of 3.7 mm. It is clearly found that, the first two resonance frequencies increase with the length of the strip ( $S_1$ ) reduced while the third resonance frequency is almost not affected. As for varying the strip length  $S_2$  to be 3.7, 3.5 and 3 mm ( $S_1 = 2.6$  mm), it can be seen from Fig. 5 that with reducing length  $S_2$ , the bandwidth for the upper band increases while the bandwidth of the lower band change slightly. For the first two resonant frequencies, to decrease the length of  $S_1$  will shorten effective current path of the second resonant frequency and also degrade the electromagnetic coupling effect which affects the first resonant frequency between  $S_1$  and the trapezoid-shaped ring at the top of the antenna, so as to move the resonant frequencies at 3.75 GHz and 2.4 GHz to higher frequencies slightly. For the third resonance frequency, it also increases with the effective current path (A-B-G-H) reduced.

The radiation characteristics of the proposed antenna are also investigated, and the measured radiation patterns of both  $E$ -plane pattern and  $H$ -plane pattern at 2.45, 3.5, 5.2 and 5.8 GHz are depicted in Fig. 6. The measured results show that the radiation patterns of the antenna are broadside and bidirectional in the  $E$ -plane and almost omnidirectional in the  $H$ -plane. The measured peak gains for the proposed antenna are 2.14, 2.54, 3.59 and 3.05 dBi at 2.43, 3.5, 5.2 and 5.8 GHz, respectively.

#### 4. CONCLUSION

A novel single-layer triangle-shaped planar antenna based on a  $50\Omega$  CPW-fed structure operating in both the WLAN communications covering the 2.4, 5.2, and 5.8 GHz bands and 3.4 GHz WIMAX application has been presented. Adjustable strips are used to enhance the bandwidth, and consequently a wide-band operation is obtained in the higher frequency band. A large operating bandwidth of 61.4% has been demonstrated. In addition, the measured radiation patterns in  $H$ -plane pattern are of a nearly omnidirectional characteristic at operating frequencies. Therefore, this antenna is a good candidate for multiband communication applications.

## REFERENCES

1. Wong, K. L., *Planar Antennas for Wireless Communications*, John Wiley & Sons, Inc., 2003.
2. Chen, S.-B., Y.-C. Jiao, F.-S. Zhang, and Q.-Z. Liu, "Modified T-shaped planar monopole antenna for multiband operation," *IEEE Transactions on Microwave Theory and Techniques*, Vol. 54, No. 8, 3267–3270, August 2006.
3. Liu, W.-C. and C.-F. Hsu, "Dual-band CPW-fed Y-shaped monopole antenna for PCS/WLAN application," *Electron. Lett.*, Vol. 41, No. 18, 390–391, 2005.
4. Liu, W. C., "Broadband dual-frequency meandered CPW-fed monopole antenna," *Electron. Lett.*, Vol. 40, 1319–1320, 2004.
5. Li, J. Y., J. L. Guo, Y. B. Gan, and Q. Z. Liu, "The tri-band performance of sleeve dipole antenna," *Journal of Electromagnetic Waves and Applications*, Vol. 19, 2081–2092, 2005.
6. Shams, K. M. Z., M. Ali, H. S. Hwang, "A planar inductively coupled bow-tie slot antenna for WLAN application," *Journal of Electromagnetic Waves and Applications*, Vol. 20, 861–871, 2006.
7. Rao, A. and R. Sebak, "T-shaped microstrip feeding technique for a dual annular slot antenna," *Journal of Electromagnetic Waves and Applications*, Vol. 19, 605–614, 2005.
8. Guo, Y., B. Gan, and Q. Z. Liu, "The tri-band performance of sleeve dipole antenna," *Journal of Electromagnetic Waves and Applications*, Vol. 19, 2081–2092, 2005.