

UNCLASSIFIED

Defense Technical Information Center  
Compilation Part Notice

ADP017227

TITLE: Multibeam Spatially-Fed Antenna Arrays with  
Amplitude-Controlled Beam Steering

DISTRIBUTION: Approved for public release, distribution unlimited

This paper is part of the following report:

TITLE: Proceedings of the 2003 Antenna Applications Symposium [27th]  
Held in Monticello, Illinois on 17-19 September 2003. Volume 1

To order the complete compilation report, use: ADA429122

The component part is provided here to allow users access to individually authored sections of proceedings, annals, symposia, etc. However, the component should be considered within the context of the overall compilation report and not as a stand-alone technical report.

The following component part numbers comprise the compilation report:

ADP017225 thru ADP017237

UNCLASSIFIED

# Multibeam Spatially-Fed Antenna Arrays with Amplitude-Controlled Beam Steering

Sebastien Rondineau, Stefania Romisch, Darko Popovic, Zoya Popovic  
Department of Electrical and Computer Engineering  
University of Colorado at Boulder, Boulder CO 80309  
[zoya@colorado.edu](mailto:zoya@colorado.edu)

**This paper presents discrete lens antenna array antennas developed for multi-beam communication applications. The lens arrays consist of two back-to-back arrays of antenna element pairs, connected by variable-length transmission lines, which allow the lens to perform a discrete Fourier transform. The array feed is a spatial one, allowing easy and affordable extensions to multiple beams, and straightforward beam reconfigurability. Two prototype arrays at X and K band are discussed. The 10-GHz lens array is designed to have multiple beams up to  $\pm 45$  degrees off broadside and dual polarization. The array is characterized in a multipath fading channel as an angle-diversity array. The K-band array is a full-duplex array operating around 25 and 27GHz with the two frequencies at two polarizations. The applications for this array are formation-flying satellites, and 5-beam performance will be presented. Continuous steering of half of a beamwidth using amplitude-only control is demonstrated.**

## 1. INTRODUCTION

Multibeam antenna arrays have numerous applications in communications. This paper addresses two such applications: angular diversity applied to a wireless mobile link and links between satellites flying in fixed formation. The goal in both cases is a low-cost array with flexibility to choose among several beams. Additionally, the requirement in the satellite link application is continuous beam steering for fine beam adjustments separately for each beam. These goals are achieved using a printed discrete lens array (DLA) with a spatial feed shared by all the beams [1-3].

A schematic of a DLA is shown in Figure 1 and is here discussed in receive mode, although the lens is reciprocal and can also be used in a transmitter. The unit element of the lens array consists of two antennas, interconnected with a delay line [1]. The length of the delay varies across the array such that an incident plane

wave is focused onto a focal point in the near field on the feed side of the array in Figure 1. The transmission lines are of different electrical length for each element: the larger delay at the central element with respect to the external ones mimics an optical lens, thicker in the center and thinner in the periphery. Together with the electrical lengths of the lines, the positions of the array elements on the feed side also determine the focusing properties of the lens. This allows for a design with up to two perfect focal points lying on a focal arc or with a cone of best focus. The two degrees of freedom are the positions of the elements on the feed side and the electrical lengths of the transmission lines connecting the two sides. The main design constraint is the equality of the path length from the feed to each element on the radiating side of the lens. Plane waves incident from different directions are focused onto different points on the focal surface, where receiving antennas and circuitry are placed to sample the image, which is a discrete Fourier transform of the incoming wavefront. Multiple receivers correspond to multiple antenna radiation pattern beams, enabling beam steering and beam forming with no microwave phase shifters.

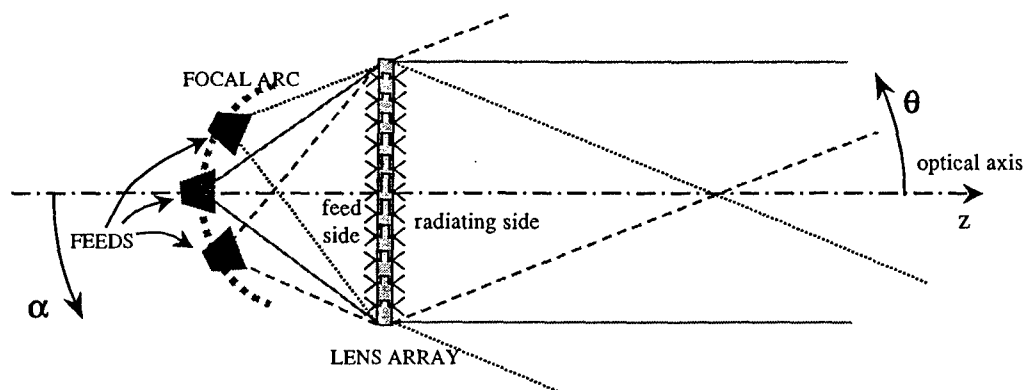

**Figure 1.** Sketch of a discrete lens array.

The lens array is planar and lightweight, fabricated using standard printed circuit technology. A standard  $N$ -element antenna array followed by a feed network is replaced by a discrete lens array in which  $N$  array element pairs perform a Fourier transform operation on the incoming wave front, and  $M < N$  receivers are placed on a focal surface sampling this image. The lens array can include integrated amplifiers in each element, and different lenses have been demonstrated for spatially-fed transmit-receive arrays at X [2] and Ka bands [3]. In active discrete lenses with distributed amplifiers, in transmission the effective radiated power (ERP) is increased with accompanied increase in reliability and efficiency, while in reception the dynamic range is improved as the low-noise amplifier (LNA) noises add incoherently, while the signal adds coherently. The lens array as the

front end of a system performs spatial separation of the input waves, which enables simplified subsequent processing. The front-end processing benefits when using a discrete lens in an adaptive array, as applied to interference and multipath propagation, were investigated in [4,5].

## 2. MULTIBEAM DLA FOR ANGLE DIVERSITY WIRELESS COMMUNICATIONS

The benefits of different types of diversity in wireless communications have been known since the first mobile radio systems [7]. Spatial [8,9,10], polarization [9,10,11], angle [8,9], or frequency diversity have been used or proposed to improve signal to noise ratio, bit error rate, channel capacity and power savings in a mobile link. Here we examine the use of more than one type of diversity in the same front-end antenna array – in specific, polarization and angle diversity. Referring to Figure 1, in a multipath environment, the line-of site wave is focused onto one receiver on the focal arc (surface), while the reflected waves are focused onto different receivers, resulting in angle diversity.

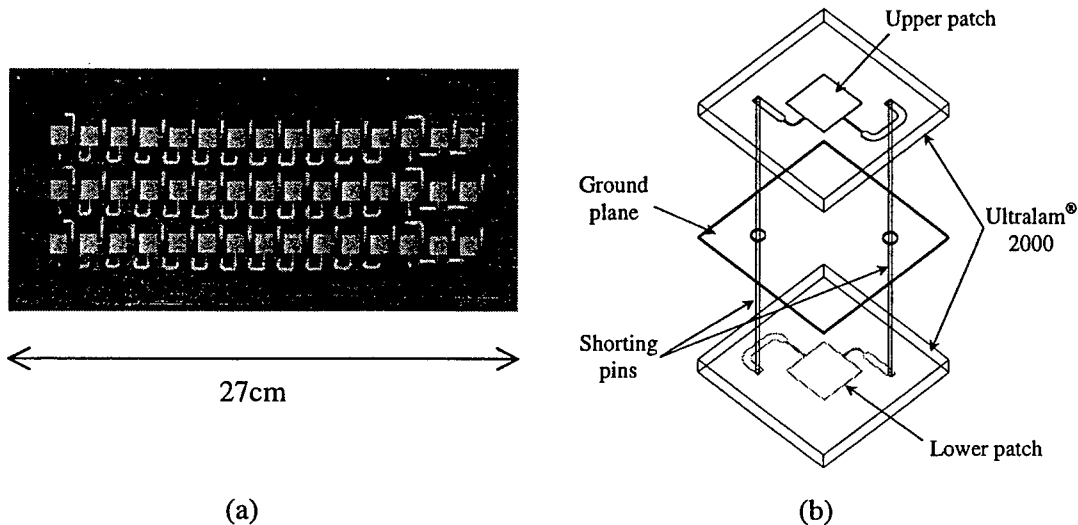
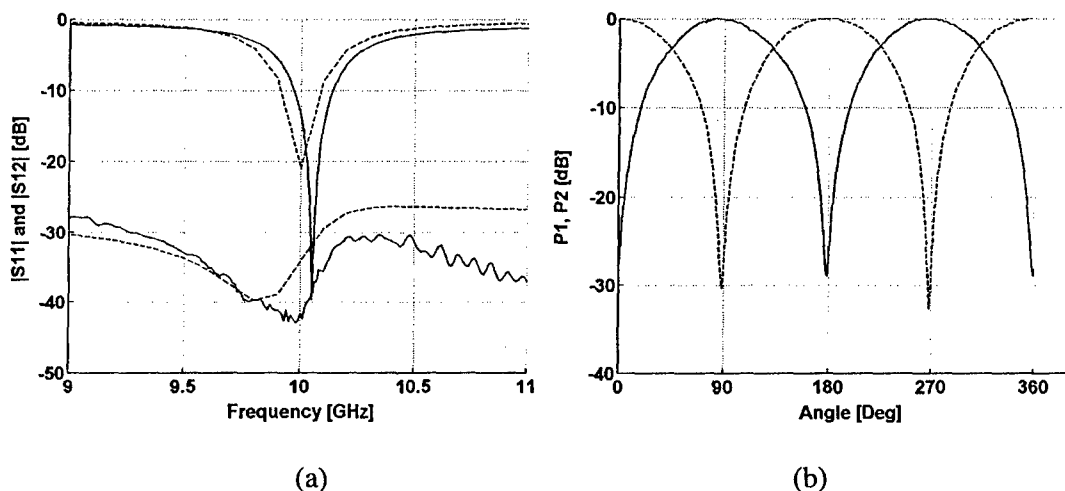

**Figure 2.** (a) Photograph of the 27-element cylindrical lens array. (b) Unit cell schematic, stretched in the vertical direction, shows the connections between antenna pair feeds corresponding to the two linear polarizations.

The lens array designed for this study is a cylindrical 45-element array with three 15-element rows, which serve to provide a fan-shaped beam in the vertical direction. The photograph of one side of the lens, Figure 2(a), shows the patch antenna elements with dual-polarization feed lines and the microstrip delay lines connected with via holes to orthogonally polarized patches on the other side of the

two-layer lens array. Orthogonal polarization between the non-feed and feed sides of the lens improves the isolation between the two sides of the lens. A single element of the lens is schematically shown in Figure 2(b). It consists of a pair of dual-polarized patch antennas printed on two microstrip substrates with a common ground plane. The substrates used in this design have a relative permittivity of 2.5 and are 0.508 mm thick. The patches designed to be resonant at 10GHz are 9.1-mm squares, and the feed points are matched to 50-ohm feed lines with quarter wave 112-ohm matching sections. Each feed line is connected with a via to the corresponding orthogonally polarized feed line of the patch on the other side of the ground plane. The vias are metal posts 0.8 mm in diameter.

The 2-port  $S$ -parameters of the single element of the array were measured using an HP8510 Network Analyzer with a 3.5 mm coaxial calibration and are compared to simulations obtained using Zeland's IE3D Method of Moments software, as shown in Figure 3(a). From these measurements, it can be seen that the isolation between the two ports of the patch is about 35 dB at resonance, which implies that the two polarization channels are practically independent and can provide polarization diversity. The axial ratio at the two ports is about 30 dB as shown in Figure 3(b), and the two feeds are seen to be in perfect quadrature, i.e. the peak of one polarization coincides with the null of the other.



**Figure 3.** (a) Measured  $s$ -parameters of one of the two ports of the dual-polarized antenna element. The other port is identical and is not shown here. (b) Measured axial ratio for the two ports of the dual-linearly polarized patch.

The element spacing in the array from Figure 2(a) is half of a free space wavelength in one plane and  $0.85\lambda$  in the other plane. The delay lines and the positions of the antenna elements at the feed side with respect to the ones at the

non-feed side are used as the design variables. They are calculated to give two perfect focal points located at the angles  $\theta_0 = \pm 45^\circ$ . The design equations are given in [1]. Since perfect focusing exists only for the plane waves incident at  $+45^\circ$  and  $-45^\circ$ , for any other angle of incidence the path-length errors are present, which in turn degrades the radiation pattern. As described in [1], these errors can be significantly reduced by "refocusing". Therefore, the feeds are not positioned at the focal arc with a constant radius equal to the focal distance, but rather at the optimum focal arc which minimizes the path length errors. The difference in length between the longest and shortest delay line is  $0.35\lambda$ , the focal distance-to-diameter ratio is  $F/D=1.5$ , with  $F=324$  mm.

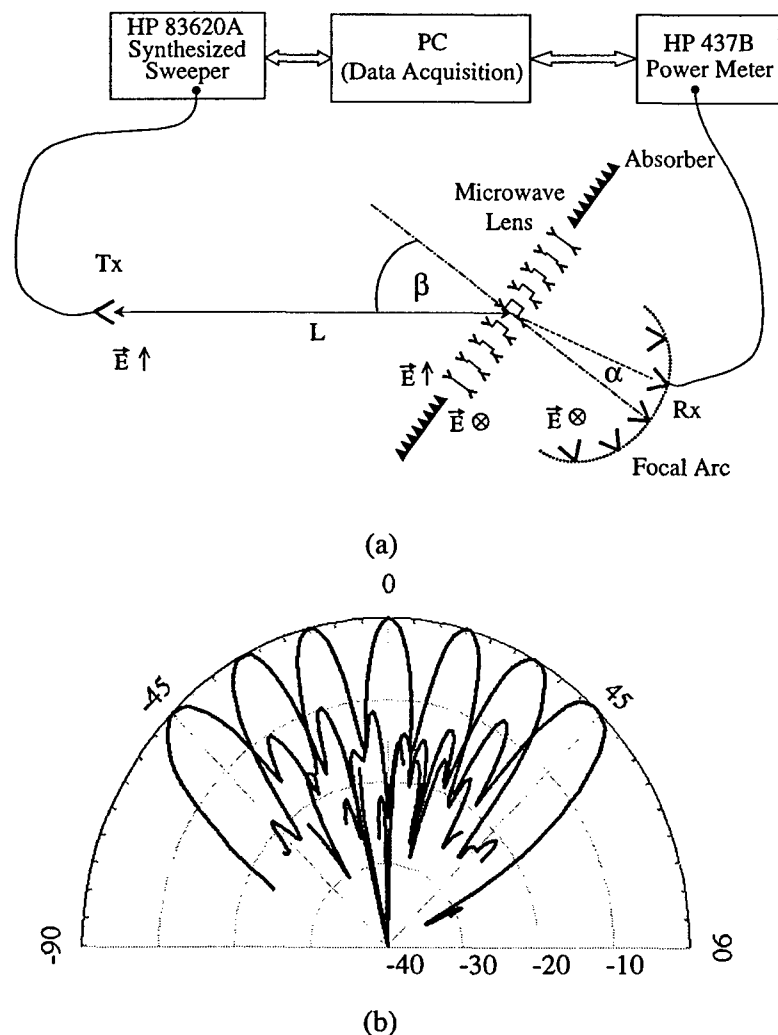

**Figure 4.** (a) Steup used for measuring the multibeam patterns. (b) Measured multibeam patterns for one of the two identical polarizatins normalized to the peak power.

The lens was characterized in an anechoic chamber using the setup shown in Figure 4(a). A standard gain horn antenna co-polarized with the non-feed side of the lens array and used as a transmitter in the measurements. For measuring radiation patterns corresponding to different beams of the multibeam lens, the lens is rotated and power detected at one receiver at a time. Linearly polarized horn antennas are used as the receiver antennas, but the same patches as the array elements can be alternatively used. The resulting normalized radiation patterns for receivers positioned between  $-45$  and  $+45$  degrees along the focal arc are shown in Figure 4(b). As the scan angle increases, the beam widens and the first sidelobe increases. The maximum received power for each of the patterns varies by about 1.5 dB, the half-power beamwidth varies by 2 degrees and the first sidelobe level varies from  $-15$  dB at 0 degrees to  $-9$  dB at 45 degrees. A example comparison between measured and calculated radiation patterns for a scan angle of 45 degrees is shown in Figure 5(a), and the measured axial ratio as a function of scan angle is shown in Figure 5(b).

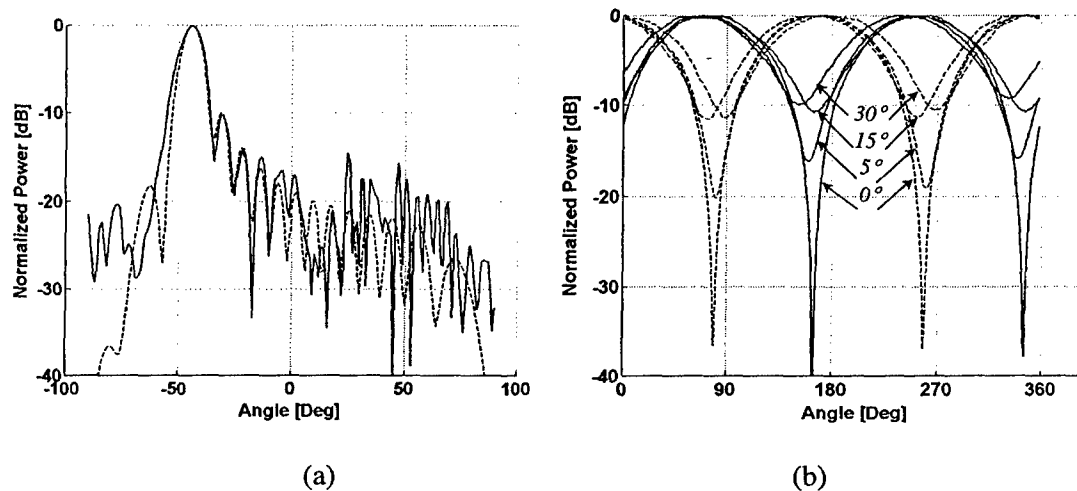

**Figure 5.** (a) Measured vs. calculated array pattern for a scan angle of  $-45$  degrees (patterns for other scan angles have similar or better agreement). (b) Measured axial ratio for the two feeds of the dual-polarized multibeam array as a function of scan angle.

Since the lens is intended to be the receiving antenna, it is important to minimize the loss in the antennas, feed lines, and spatial feed, as any loss before the LNAs has a detrimental effect on the noise figure. In order to obtain an indication of lens efficiency, "thru" measurements are performed using an HP8510 Network Analyzer. The transmitting and the receiving horn antennas are connected to ports one and two of the network analyzer, respectively. The antennas are copolarized

and the system is calibrated using the “response/thru” calibration and time gating, from 9 to 11 GHz. The lens array is then inserted in front of the receiving horn antenna. It was mentioned before that the lens array has built-in polarization isolation and therefore the receiving horn antenna has to be rotated by 90 degrees. The lens array is mounted in an absorber aperture of the same size as the lens, and the total absorber size is a square 60 cm on the side. The measurements were made for the system that is calibrated in two ways: without the absorber and through the aperture in the absorber. The “thru” loss measured in this way is between 0.7 and 4dB.

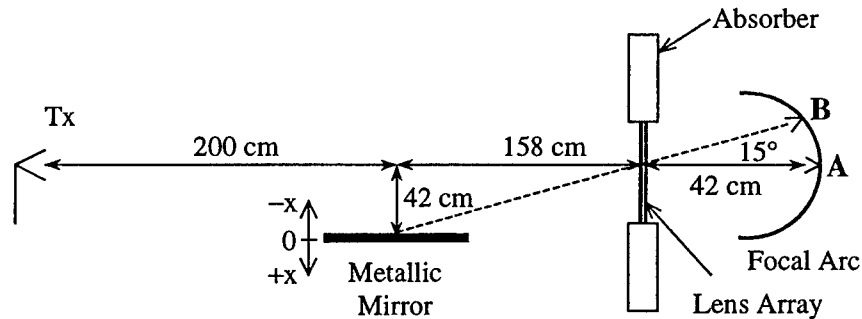

Figure 6. Measurement set up for determining improvement in multipath fading nulls.

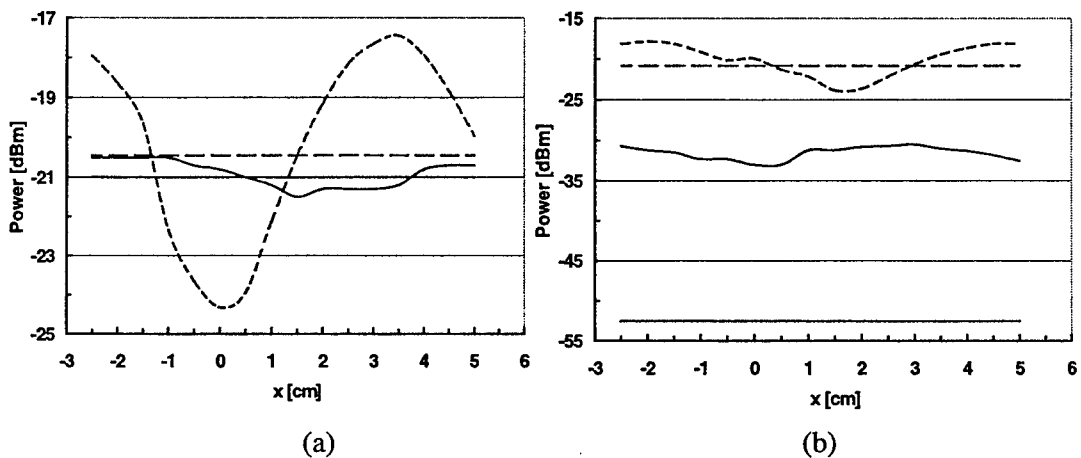

Figure 7. Measured received co-polarized power in the presence of a reflector without lens in link (dashed line) and with the lens added at the front end of the receiver (solid line). The receiver is positioned for a beam at 0 degrees (a) and 15 degrees (b). The straight lines show the reference power levels received with no reflector (no multipath) in the link, for 500mW input power to the transmitting horn antenna in Figure 6.



In order to test improvements in a link in a multipath fading environment when the lens is used at the front end, the lens is placed in a simple controllable multipath environment consisting of a single metal reflector in an anechoic chamber, as shown schematically in Figure 6. The reflector is  $15 \times 15$  free-space wavelengths large and is translated in the  $x$  direction over three free-space wavelengths. The reflector is positioned so that at  $x=0$ , the reflected wave from the transmitting horn falls into the second null of the lens antenna pattern for a receiver on the optical axis (receiver A in Figure 6). In the first set of measurements, the received power in a line-of-sight link between the transmitting horn antenna and the receiver patch, with no lens array present, was measured without the presence of the mirror, and then as the mirror was translated in the  $x$  direction. The power at the input of the transmitting horn is 500 mW. The straight horizontal lines on the plots in Figure 7 are the measured power for the direct link only, without the reflector present. When the reflector is added, there is a standing wave behavior typical of a multipath environment. When the lens array is placed in front of the receiving antenna, the multipath peak-to-null ratio is significantly reduced, partly due to the gain of the array, and partly due to the built-in angle diversity.

When the receiver is positioned at point B on the focal arc corresponding to a beam at 15 degrees, the reference level of the received signal without the mirror is 30 dB below the reference level measured with the feed on optical axis (straight solid lines in Figure 7. This agrees well with the second null at 15 degrees in the radiation pattern in Figure 4(b), which is about 30 dB below the main beam. When the metallic mirror is placed in the experiment, the level of the signal is on average raised by 20 dB compared to the reference power level measured without the mirror (solid lines in Figure 7(b)). Therefore, it is demonstrated experimentally that the reflected multipath signal is spatially separated from the direct signal, and the two are received separately and can subsequently be combined.

### 3. MULTIBEAM DLA FOR SATELLITE CROSS LINKS

Many antenna systems can benefit from simultaneous multiple beams, one example being satellites flying in fixed formation [16], as well as base-station antennas for wireless communications. This paper addresses the development of a multi-beam lens array antenna for cross-link communications between satellites in tight formation, intended to collect diverse scientific mission data. The application considered requires several simultaneous dual-frequency dual-polarization beams

at different angles. The pointing angle of each beam needs to be fine-tuned continuously by about half of the half-power beamwidth to allow pointing corrections with satellites slightly out of formation. A standard way to perform beam forming and steering is with phased array antennas. A multibeam phased array would require a multi-layer feed structure such as a Butler matrix [3]. The feed network has limited bandwidth and includes lossy phase shifters (typically above 10dB at millimeter wavelengths). The approach in this work is to design a Ka-band DLA such as the one in Figure 1, with the polarization, up- and down-link frequencies, beamwidths and fine tuning requirements needed for a satellite crosslink demonstration prototype.

The DLA operates at 24.7 and 26.7GHz up and downlink frequencies, and is a two-degree of freedom design for a cone of best focus of  $\pm 30$  degrees. The antenna elements are rectangular patch antennas fed from the radiating edges for crossed polarization at the two frequencies. The element bandwidth is measured to be 3% for both frequencies. To satisfy the beam requirement of a 10-degree half-power beamwidth, 64 elements are distributed on triangular lattice with  $0.6\lambda$  and  $\lambda$  periods in the horizontal and vertical directions, as shown in Figure 8. The patch pair is connected with slot couplers in the antenna ground planes to a common buried delay-line stripline layer, resulting in a 5-layer DLA implementation. The delay line lengths range from  $0.11\lambda$  to  $1.05\lambda$  with the longest corresponding to the central array element.

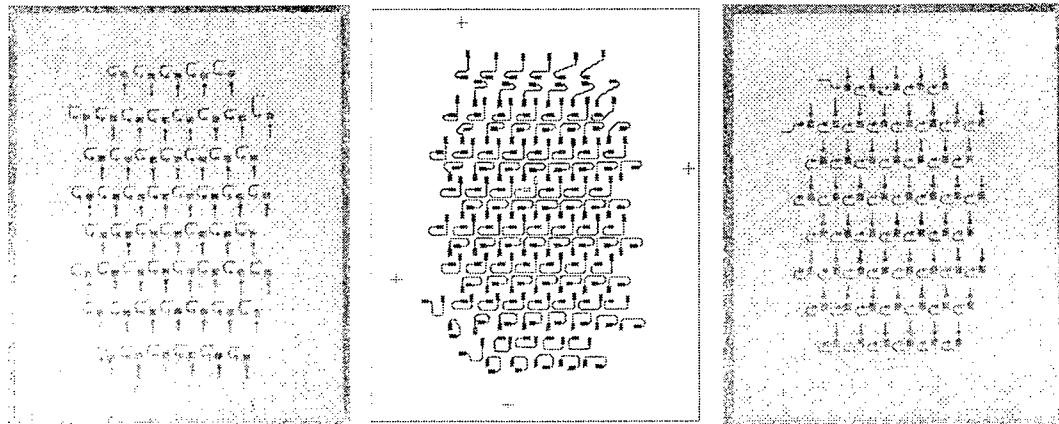
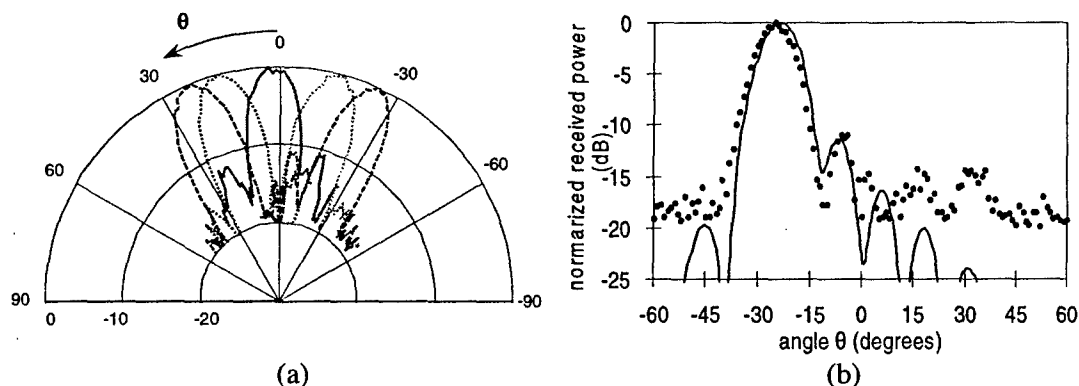

**Figure 8.** Photographs of the two sides of the 64-element DLA and layout of the sandwiched stripline delay line layer.

Figure 9(a) shows the radiation patterns measured at 26.7GHz at University of Colorado for five different positions of a waveguide feed along the focal arc.

Figure 9(b) shows the simulated versus measured single beam pattern at -25 degrees.

The lens array performs a discrete Fourier transform, in analogy to an optical dielectric lens performing a Fourier transform. Because of this property of DLAs, amplitude variations at the feed on the focal surface correspond to phase shifts at the non-feed side, which in turn correspond to a steering of the beam. Each feed of the dual-beam array was implemented with a 2-element array of patch antennas, spaced  $\lambda$  apart. The power radiated/received by each element is controlled with variable-gain attenuators or amplifiers so that the ratio between them can be varied to steer the beam, as illustrated in Figure 10(a). The measurement for a power ratio between 0.13 and 0.96 is shown in Figure 10(b).

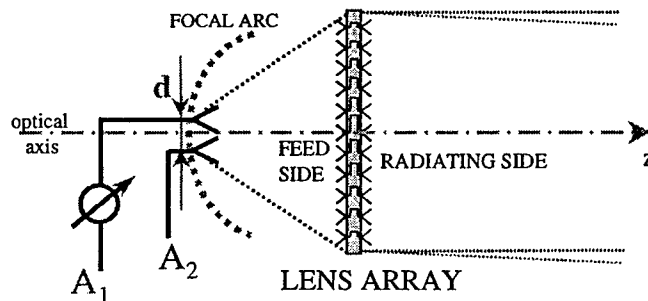

**Figure 9.** (a) Measured 5-beam pattern at 26.7GHz (the patterns at the lower frequency look very similar). (b) Measured and simulated pattern steered at -25 degrees off broadside.

#### 4. DISCUSSION AND CONTINUED WORK

This paper describes a front end discrete lens antenna array as it applies to: (1) wireless communications with more than one diversity type and (2) low-cost phase-shifterless beamforming. The lens array is shown to be a multibeam array that can be designed to have low loss for large numbers of elements for two orthogonal well-isolated (30dB) polarizations. In a transmitter, where each element can have a power amplifier, the powers will add coherently. In a receiver application where low-noise amplifiers are integrated in each antenna element, the noises add incoherently, while the signals add coherently at the receivers along the focal arc, therefore increasing the RF dynamic range by  $10\log N$ . Loss in the lens will degrade the noise figure, and a loss budget for DLAs needs to be

performed. Measurements with a calibrated “thru” as described above in Section 2 give an indication of how efficient the system is in collecting RF power relative to the system without the lens array. Since the effective area is increased with the presence of the lens array we would expect to be able to collect more power. However, due to a variety of loss mechanisms, such as spill-over loss, nonuniform illumination loss, mismatch loss and ohmic loss, the total received power is in most cases below the level that we would receive using the receiver antenna alone. The main contributor is the spill-over loss, meaning that power is lost due to the fact that the effective area of the feed antenna on the focal surface is not large enough to collect all the power of the image. This loss can be significantly reduced if the lens array and the receiving antenna are designed as a system, which was attempted in the case of the 10-GHz lens described in Section 2, giving as low as 0.7dB “thru” loss. This means that the total DLA loss is roughly equal to the array gain, and this can be compensated with a pre-amplifier in transmission, and some added LNA gain in reception.



(a)

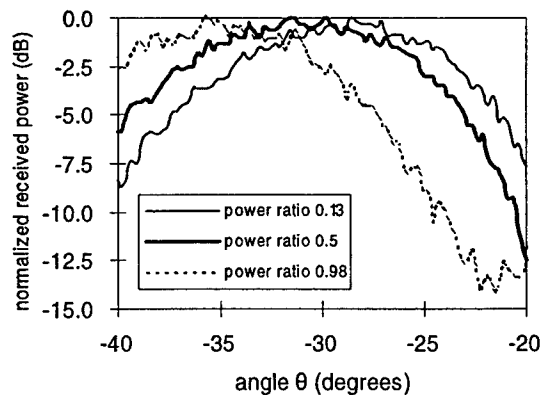

(b)

**Figure 10.** (a) Setup for amplitude controlled fine beam steering. (b) Measured beam steering using an amplitude ratio of

The lens array is a multibeam array with a single spatial feed, and an important parameter is isolation between the beams. In the angle diversity application, the "crosstalk" between the beams will result in correlated diversity orders, reducing ultimately channel capacity. In a multibeam system, the crosstalk will determine how many independent beams can be reasonably used for an N-element DLA. Theoretically, an N-element lens has N independent beams, but in practice this number will be limited by the coupling between the beams and the scan angle. Figure 11 shows measured coupling between two feed antennas positioned for -30 degree and +30 degree beams, along with coupling of the two feeds on the same dual frequency feed antenna of the Ka-band DLA.

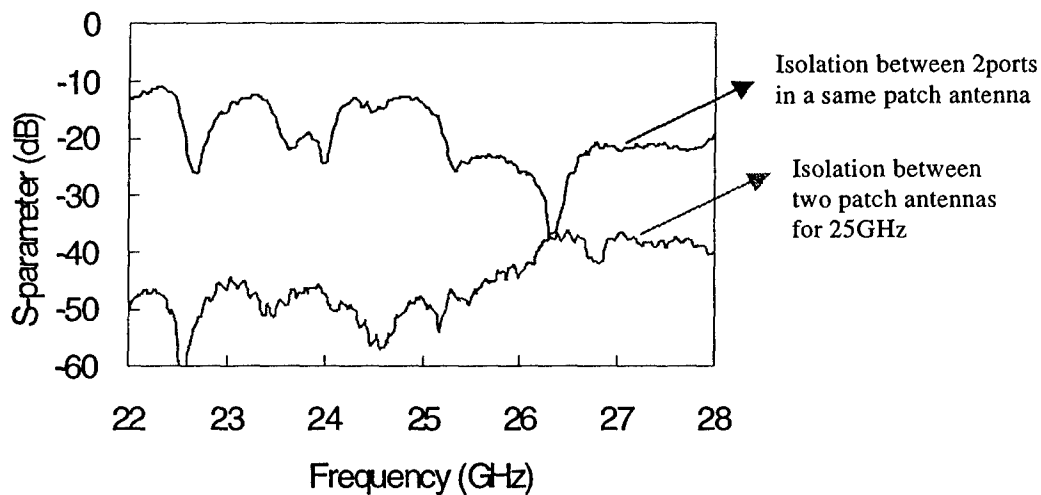

**Figure 11.** Measured isolation ( $s_{21}$ ) between two ports on the same antenna and two ports on the two different feed antennas for the Ka-band dual-frequency DLA with feed antennas positioned at -30 degrees and +30 degrees off broadside.

It is important to note here one advantage of the discrete lens arrays over phased arrays. The phased array feeds for large number of beams and elements become very complex and contribute to a huge increase in cost and losses. In lenses, however, the feed network complexity and losses scale favorably [18].

#### ACKNOWLEDGEMENT

This work was funded by the NSF Wireless Initiative ECS-9979400, and the NASA Glenn Research Center. We thank Dr. Richard Lee at the NASA Glenn Research Center for many helpful suggestions.

## REFERENCES

- [1] D.T. McGrath, "Planar three-dimensional constrained lenses," *IEEE Trans. Antennas Propag.*, vol.AP-34, pp. 46-50, Jan.1986.
- [2] S. Hollung, A. Cox, Z. Popovic, "A quasi-optical bi-directional lens amplifier," *IEEE Trans. on Microwave Theory and Techniques*, Vol. 47, No. 12, pp. 2352-2357, Dec. 1997.
- [3] Z. Popovic, A. Mortazawi, "Quasi-optical transmit/receive front ends," *invited paper, IEEE Trans. on Microwave Theory and Techniques*, Vol. 48, No. 11, pp. 1964-1975, Nov. 1998.
- [4] D. Z. Anderson, V. Damiao, E. Fotheringham, D. Popovic, S. Romisch, Z. Popovic, "Optically smart active antenna arrays," *IEEE Trans. on Antennas and Propagations*, Vol.50, No5. , pp.607-617, May 2001.
- [5] J. Vain, Z. Popovic, "Smart lens antenna arrays," *IEEE 2001 IMS Symposium Digest*, pp. 129 – 132, Phoenix, Arizona, May 2001.
- [6] D. Popovic, Z. Popovic, "Multibeam antennas with polarization and angle diversity," *IEEE Trans. on Antenna and Propagation*, Vol.50, No.5, Special Issue on Wireless Communications, pp. 651-657, May 2002.
- [7] *Microwave mobile communications*, W. C. Jakes, ed., reprinted by IEEE Press, Piscataway, NJ, 1994.
- [8] W. L. Stutzman, J. H. Reed, C. B. Dietrich, B. K. Kim and D. G. Sweeney, "Recent results from smart antenna experiments – base station and handheld terminals," *Proceedings RAWCON*, September 2000, pp. 139-142
- [9] P. L. Perini and C. L. Holloway, "Angle and space diversity comparisons in different mobile radio environments," *IEEE Transactions on Antennas and Propagation*, Vol. 46, No. 6, June 1998, pp. 764-775
- [10] B. S. Collins, "Polarization diversity antennas for compact base stations", *Microwave Journal*, Vol. 43, No. 1, January 2000, pp. 76-88.
- [11] C. Beckman and U. Wahlberg, "Antenna systems for polarization diversity," *Microwave Journal*, Vol. 40, No. 5, May 1997, pp. 330-334.
- [12] *Microstrip antennas: the analysis and design of microstrip antennas and arrays*, D. M. Pozar and D. H. Schaubert, IEEE Press, Piscataway, NJ, 1995.
- [14] S. Hollung, *Quasi-Optical Transmit/ Receive Lens Amplifier Arrays*, Ph.D. Thesis Dissertation, University of Colorado, Boulder, 1998.
- [16] R.Q. Lee, S. Romisch and Z. Popovic, "Multi-Beam Phased Array Antennas," 26th Annual Antenna Applications Symposium, Sept. 2002, Monticello, Illinois.
- [17] Hansen R. C., *Phased array antennas*, Wiley Series in Microwave and Optical Engineering, Kai Chang Series Editor, Ch. 10, 1998.
- [18] S. Römisch, N. Shino, D. Popović, P. Bell, Z. Popović, "Multibeam planar discrete millimeter-wave discrete lens for fixed formation satellites," *2002 URSI General Assembly Digest*, Maastricht, The Netherlands, August 2002.