

 Open access • Journal Article • DOI:10.1109/MCS.2009.932927

## Multidomain modeling of nonlinear networks and systems — [Source link](#)

Dimitri Jeltsema, Jacquélien M.A. Scherpen

**Institutions:** Delft University of Technology

**Published on:** 31 Jul 2009 - IEEE Control Systems Magazine (IEEE)

**Topics:** Nonlinear system, Equations of motion, Hamiltonian (quantum mechanics), Analytical mechanics and Distributed parameter system

Related papers:

- [Interconnection and damping assignment passivity-based control of port-controlled Hamiltonian systems](#)
- [A theory of nonlinear networks. I](#)
- [L2-Gain and Passivity Techniques in Nonlinear Control](#)
- [Power shaping: a new paradigm for stabilization of nonlinear RLC circuits](#)
- [Brief paper: Power-based control of physical systems](#)

Share this paper:    

View more about this paper here: <https://typeset.io/papers/multidomain-modeling-of-nonlinear-networks-and-systems-54d657mxnq>

University of Groningen

## Multidomain Modeling of Nonlinear Networks and Systems ENERGY- AND POWER-BASED PERSPECTIVES

Jeltsema, Dimitri; Scherpen, Jacquélien M. A.

*Published in:*  
IEEE Control Systems Magazine

*DOI:*  
[10.1109/MCS.2009.932927](https://doi.org/10.1109/MCS.2009.932927)

**IMPORTANT NOTE: You are advised to consult the publisher's version (publisher's PDF) if you wish to cite from it. Please check the document version below.**

*Document Version*  
Publisher's PDF, also known as Version of record

*Publication date:*  
2009

[Link to publication in University of Groningen/UMCG research database](#)

*Citation for published version (APA):*

Jeltsema, D., & Scherpen, J. M. A. (2009). Multidomain Modeling of Nonlinear Networks and Systems ENERGY- AND POWER-BASED PERSPECTIVES: Energy- and power-based perspectives. *IEEE Control Systems Magazine*, 29(4), 28-59. <https://doi.org/10.1109/MCS.2009.932927>

### Copyright

Other than for strictly personal use, it is not permitted to download or to forward/distribute the text or part of it without the consent of the author(s) and/or copyright holder(s), unless the work is under an open content license (like Creative Commons).

The publication may also be distributed here under the terms of Article 25fa of the Dutch Copyright Act, indicated by the "Taverne" license. More information can be found on the University of Groningen website: <https://www.rug.nl/library/open-access/self-archiving-pure/taverne-amendment>.

### Take-down policy

If you believe that this document breaches copyright please contact us providing details, and we will remove access to the work immediately and investigate your claim.

Downloaded from the University of Groningen/UMCG research database (Pure): <http://www.rug.nl/research/portal>. For technical reasons the number of authors shown on this cover page is limited to 10 maximum.

# Multidomain Modeling of Nonlinear Networks and Systems

## ENERGY- AND POWER-BASED PERSPECTIVES



D.S. BERNSTEIN

Digital Object Identifier 10.1109/MCS.2009.932927

Many physical systems, including mechanical, electrical, electromechanical, fluid, and thermal systems, can be modeled by the Lagrangian and Hamiltonian equations of motion [1]–[5]. A key aspect of the Lagrangian and Hamiltonian frameworks is the role of energy storage. Apart from the fact that energy is a fundamental concept in physics, there are several motivations for adopting an energy-based perspective in modeling physical systems. First, since a physical system can be viewed as a set of simpler subsystems that exchange energy among themselves and the environment, it is common to view dynamical systems as energy-transformation devices. Second, energy is neither allied to a particular physical domain nor restricted to linear elements and systems. In fact, energies from different domains can be combined simply by adding up the individual energy contributions. Third, energy can serve as a *lingua franca* to facilitate communication among scientists and engineers from different fields. Lastly, the role of energy and the interconnections between subsystems provide the basis for various control strategies [4], [6]–[8].

In multidomain Lagrangian and Hamiltonian modeling it is necessary to distinguish between two types of energies, *energy* and *co-energy*. Energy is the ability to do work, while co-energy is the *complement of*

DIMITRI JELTSEMA and  
JACQUELIEN M.A. SCHERPEN

energy as defined and used in [3] and [9]–[15]. To elucidate the distinction between energy and co-energy, consider a point mass  $M > 0$  moving in the  $x$ -direction. In the nonrelativistic case, the momentum  $p$  is related to the velocity  $v = dx/dt$  by the linear constitutive relationship  $p = Mv$ , and Newton's second law is given by  $F = dp/dt$ , where  $F$  is the force acting on the mass. If the mass is moved by the force, then the increment of work done by the force is  $Fdx$ , which can be written as

$$Fdx = \frac{dp}{dt} dx = dp \frac{dx}{dt} = vdp = \frac{p}{M} dp.$$

Since the kinetic energy of the mass is given by the integral of the work done by the force, integrating  $v = p/M$  from zero to  $p$  results in

$$T(p) = \frac{p^2}{2M}.$$

When plotted in the  $v$ -versus- $p$  plane as Figure 1(a),  $T(p)$  represents the area of the triangular region below the line  $p = Mv$  and to the left of the dashed vertical line. On the other hand, the complementary kinetic energy, that is, the *kinetic co-energy*,  $T^*$  is defined to be the area of the triangular region above the line  $p = Mv$  and below the horizontal dashed line. The kinetic co-energy cannot be obtained directly from work but rather is defined in a complementary or dual fashion as the integral of the momentum with respect to the velocity, which, referring to Figure 1(a), is tantamount to extracting the triangular area defined by  $T(p)$  from the total square area defined by the product  $pv$ , that is,

$$T^*(v) = pv - T(p) = \frac{M}{2} v^2.$$

Note that the kinetic energy is quadratic in  $p$ , while the kinetic co-energy is quadratic in  $v$ , and, furthermore,  $T(p) = T^*(v)$ . Because of this equality, it is traditional to not make a distinction between  $T(p)$  and  $T^*(v)$ , and as a result  $T^*(v)$  is commonly called the kinetic energy rather than the kinetic co-energy. When the momentum  $p$  and the velocity  $v$  are not linearly related, however,  $T(p)$  and  $T^*(v)$  are generally different. In fact, when relativistic effects are considered,  $p$  and  $v$  are related by the nonlinear constitutive relationship

$$p = \frac{M_0 v}{\sqrt{1 - v^2/c^2}}, \quad (1)$$

where  $M_0$  denotes the rest mass and  $c$  is the velocity of light. Consequently, for a relativistic mass, the area of the region below the  $v$ -versus- $p$  curve is not equal to the area of the region above the  $v$ -versus- $p$  curve, as shown in Figure 1(b), and thus the kinetic energy  $T(p)$  is no longer equal to the kinetic co-energy  $T^*(v)$ , even though the units of both  $T(p)$  and  $T^*(v)$  are Joules (J).

For mechanical systems, the starting point in setting up the Lagrangian equations of motion is to determine the *Lagrangian*. The Lagrangian is defined as the difference between the total stored kinetic co-energy associated with the masses and moments of inertia and the total potential energy associated with gravitational forces and stiffness elements. The Lagrangian equations of motion give a force balance in terms of displacement and velocity, explaining why, instead of the kinetic energy, the kinetic co-energy is used for the Lagrangian. More details on co-energy and the Lagrangian equations of motion are given in the section "Classical Energy-Based Framework."

An analogous situation occurs in the case of electrical networks. For both linear and nonlinear electrical networks, energy can be stored magnetically in inductors and electrically in capacitors, and these quantities can be used to derive Lagrangian equations of motion. In particular, the *magnetic energy* is defined to be the integral of the current with respect to the flux linkage, whereas the *magnetic co-energy* is defined as the integral of flux linkage with respect to current. For linear networks, the relationship between flux linkage and current is linear, and thus the magnetic energy and the magnetic co-energy are equal. However, for nonlinear networks, these quantities are generally different, similar to the case of the kinetic energy and kinetic co-energy of the relativistic mass described above. The network Lagrangian is the difference between the total magnetic co-energy and the total electric energy, where the electric energy is the integral of voltage with respect to

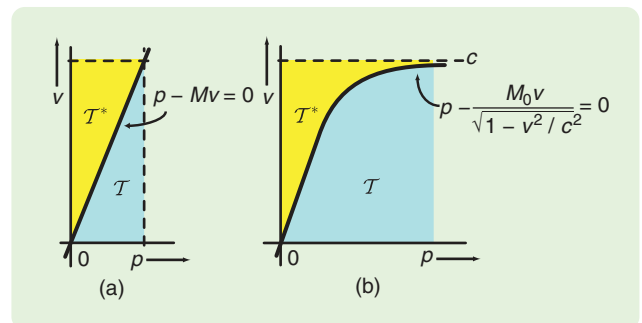

**FIGURE 1** Kinetic energy versus kinetic co-energy. (a) Constitutive relationship of a nonrelativistic mass  $M$  plotted in the velocity  $v$  versus momentum  $p$  plane. The kinetic energy is represented by the region below the line defined by the equation  $p - Mv = 0$ , whereas the region above the line represents the kinetic co-energy. For a constant mass, the areas of the two regions are equal. Hence the kinetic energy coincides with the kinetic co-energy. Note that the relationship between momentum and velocity expresses the original version of Newton's second law, that is,  $F = dp/dt$ , with  $p = Mv$ . For a constant mass, the latter coincides with the version  $F = Ma$ . An advantage of stating Newton's second law in terms of the relationship between momentum and velocity is that it is also valid when  $M$  changes in time, a situation where  $F = Ma$  loses its validity. (b) For a relativistic mass, Newton's second law can be extended to Einstein's relativistic law of motion by replacing the linear constitutive relationship  $p = Mv$  by the nonlinear function given in (1). In this case, the kinetic energy clearly differs from the kinetic co-energy.

## State Functions

A key aspect in the classical modeling procedures of analytical mechanics, due to Lagrange in the late 18th century, is the use of *state functions*. A state function is a scalar function that depends only on the current state of the system irrespective of the way in which the system reached that state. To physically motivate the idea of a state function, kinetic and potential energy storage, which are in itself state functions, are combined to form the Lagrangian. In the case of a conservative system, the equations of motion can be derived from the Lagrangian and thus from knowledge of the kinetic and potential energy contributions alone. Nonconservative forces, such as forces due to linear viscous friction, can be included by means of a Rayleigh dissipation function, which was introduced in 1873 by Lord Rayleigh [16]. Instead of energy, the values of this quadratic function have

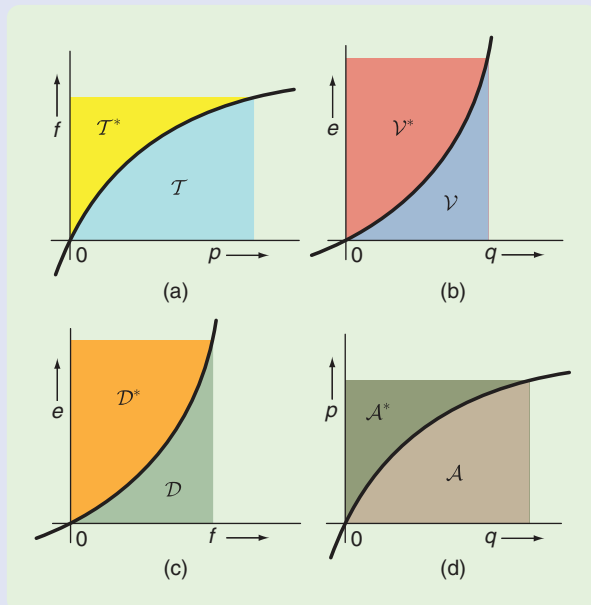

**FIGURE S1** Constitutive relationships and state functions. The graph in (a) illustrates the constitutive relationship of a nonlinear inductive element. The area  $\mathcal{T}$  below the curve is the inductive energy, whereas the area  $\mathcal{T}^*$  above the curve is the inductive co-energy. In the nonlinear case, inductive energy generally differs from inductive co-energy. However, for a linear inductive element the constitutive relationship is a straight line through the origin, and thus the inductive energy coincides with the inductive co-energy. The constitutive relationship in (b) corresponds to a capacitive element, where the capacitive energy and capacitive co-energy are the areas  $\mathcal{V}$  and  $\mathcal{V}^*$  below and above the curve, respectively. In a similar fashion, the constitutive relationship of a resistive element shown in (c) separates the effort-flow plane into two areas, which are denoted as resistive content  $\mathcal{D}$  and co-content  $\mathcal{D}^*$ . Figure (d) shows the state functions associated with a memristive element, which are the memristive action  $\mathcal{A}$  and the memristive co-action  $\mathcal{A}^*$ . Note that in (c) the sum of the content and co-content defines the total power of the element, whereas the sum of the energy and co-energy, as well as the sum of the action and co-action, have no physical meaning.

the units of power. Many years later, Wells introduced a power function that is applicable to a much wider range of nonconservative forces [S1], [S2]. In the context of nonlinear network theory, the generalization of energy and power functions is due to Cherry and Millar in the early 1950s. Cherry [9] introduced a function dual to the energy called the *co-energy*, whereas Millar [18] generalized Maxwell's minimum heat theorem to nonlinear networks by defining the *content* and *co-content* functions. The use of co-energy (at that time called dualistic or complementary energy) can be traced to the work of Count Ménebréa [S3], Maxwell [S4], and Essenger [13] in the 19th century.

The energy, co-energy, content, and co-content are now defined on basis of the element quadrangle of Figure 2. The state functions associated with memristive elements are known as *action* and *co-action* [22]. We first discuss one-port (that is, two-terminal) elements. The extension to multiport elements is then discussed.

### INDUCTIVE ENERGY AND CO-ENERGY

An element that is characterized by a relationship between flow  $f$  and generalized momentum  $p$  is called an inductive or "I" element. Examples of inductive elements include a mechanical mass or an electrical inductor. More specifically, an inductive element is described by either a  $p$ -controlled constitutive relationship

$$f = \hat{f}(p)$$

or an  $f$ -controlled constitutive relationship

$$p = \hat{p}(f).$$

If both relationships are invertible, the element is said to be one to one. Graphically, the constitutive relationships represent a curve separating the associated  $f$ - $p$  plane into two areas; see Figure S1(a). The area below the curve represents the inductive energy

$$\mathcal{T}(p_t) = \int_0^{p_t} \hat{f}(p) dp, \quad (\text{S1})$$

whereas the area above the curve represents the inductive co-energy

$$\mathcal{T}^*(f_t) = \int_0^{f_t} \hat{p}(f) df. \quad (\text{S2})$$

Inductive energy and inductive co-energy are also referred to as generalized kinetic energy and generalized kinetic co-energy. Note that in the linear case the constitutive relations are straight lines through the origin so that inductive energy coincides with inductive co-energy, that is,  $\mathcal{T}(p_t) = \mathcal{T}^*(f_t)$ .

### CAPACITIVE ENERGY AND CO-ENERGY

An element that is characterized by a relationship between effort  $e$  and generalized displacement  $q$  is called a capacitive or "C" element. Examples of a capacitive element include a mechanical

spring or an electrical capacitor. More specifically, a capacitive element is described by either a  $q$ -controlled constitutive relationship

$$e = \hat{e}(q),$$

or an  $e$ -controlled constitutive relationship

$$q = \hat{q}(e).$$

If both relationships are invertible, the element is said to be *one-to-one*. The constitutive relationships of a capacitive element separate the associated  $e$ - $q$  plane into two areas; see Figure S1(b). The area below the curve represents the capacitive energy

$$\mathcal{V}(q_c) = \int_0^{q_c} \hat{e}(q) dq, \quad (S3)$$

whereas the area above the curve represents the capacitive co-energy

$$\mathcal{V}^*(e_c) = \int_0^{e_c} \hat{q}(e) de. \quad (S4)$$

Capacitive energy and co-energy are often also referred to as generalized potential energy and co-energy.

### RESISTIVE CONTENT AND CO-CONTENT

A resistive or "R" element, such as viscous friction, electrical resistance, externally supplied forces or velocities, and voltage and current sources, relates effort with flow, or vice versa. Again we have two specific situations, namely, an  $f$ -controlled resistive element

$$e = \hat{e}(f),$$

and an  $e$ -controlled resistive element

$$f = \hat{f}(e),$$

separating the associated  $e$ - $f$  plane into two areas. The area below the curve of Figure S1(c) represents the resistive content

$$\mathcal{D}(f_r) = \int_0^{f_r} \hat{e}(f) df, \quad (S5)$$

whereas the area above the curve of Figure S1(c) represents the resistive co-content

$$\mathcal{D}^*(e_r) = \int_0^{e_r} \hat{f}(e) de. \quad (S6)$$

Note that the sum  $\mathcal{D}(f_r) + \mathcal{D}^*(e_r) = e_r f_r$  of the content and co-content defines the total power supplied to or extracted from the element, whereas the sum of the energy and co-energy, as well as the sum of the action and co-action defined below, is devoid of physical meaning.

### MEMRISTIVE ACTION AND CO-ACTION

A memristive or "M" element relates generalized momentum with displacement, or vice versa, and admits a  $q$ -controlled relationship

$$p = \hat{p}(q),$$

or a  $p$ -controlled relationship

$$q = \hat{q}(p).$$

The area below and above the curve in the  $p$ - $q$  plane (see Figure S1(d)) represents the memristive action

$$\mathcal{A}(q_m) = \int_0^{q_m} \hat{p}(q) dq, \quad (S7)$$

and memristive co-action

$$\mathcal{A}^*(p_m) = \int_0^{p_m} \hat{q}(p) dp, \quad (S8)$$

respectively.

### SOURCES

Observe that in Figure 2 the four classifications are not mutually exclusive. For example, a constant effort source, such as gravity, can be regarded as either a resistive or a capacitive element; for instance, in Figure S1(b) or (c), gravity can be represented by a horizontal line. Similarly, a flow source can be regarded as either a resistive or an inductive element; see [S8] for a discussion in the electrical domain.

### MULTIVARIABLE CASE

Usually a system consists of more than one of each of the available elements. For example, for a system containing  $n_l$  possibly mutually coupled inductive elements, the flow and generalized momentum variables  $f$  and  $p$  are  $n_l$ -dimensional vectors. Hence, the constitutive relationships  $f = \hat{f}(p)$  and  $p = \hat{p}(f)$  are vector functions, and  $\mathcal{T}$  and  $\mathcal{T}^*$  represent the total inductive energy and total inductive co-energy, respectively, which are determined by the sum of the individual energy and co-energy contributions, respectively. Thus,

$$\begin{aligned} \mathcal{T}(p_l) &= \sum_{k=1}^{n_l} \int_0^{p_k} \hat{f}_k(\dots, p_k, \dots) dp_k \\ &= \int_0^{p_l} \hat{f}^\top(p) dp, \end{aligned}$$

and

$$\begin{aligned} \mathcal{T}^*(f_l) &= \sum_{k=1}^{n_l} \int_0^{f_k} \hat{p}_k(\dots, f_k, \dots) df_k \\ &= \int_0^{f_l} \hat{p}^\top(f) df. \end{aligned}$$

Furthermore,  $\mathcal{T}(p_l)$  and  $\mathcal{T}^*(f_l)$  are related through the Legendre transformation

$$\mathcal{T}^*(f_l) = p_l^\top f_l - \mathcal{T}(p_l),$$

where  $p_l = \nabla_{f_l} \mathcal{T}^*(f_l)$  and  $f_l = \nabla_{p_l} \mathcal{T}(p_l)$ . Similar extensions apply to the remaining state functions.

### REFERENCES

- [S1] D. A. Wells, *Schaum's Outline of Lagrangian Dynamics*. New York: McGraw Hill, 1967.
- [S2] F. A. Fuenes, "On the power function," *J. Appl. Phys.*, vol. 17, p. 712, 1946.
- [S3] O. I. Franksen, "The nature of data: From measurements to systems," *BIT Numer. Math.*, vol. 25, no. 1, pp. 24–50, 1985.
- [S4] J. C. Maxwell, *Matter and Motion*. New York: Dover, 1991.

## The Brayton-Moser equations rely on the existence of a function called the mixed-potential function.

charge. For fluid systems, the fluid kinetic co-energy and the fluid potential energy are defined in the same manner as for mechanical systems by using the analogy of force and pressure, as well as the analogy of mass velocity and flow velocity. Therefore, the fluid Lagrangian is the difference between the total fluid kinetic co-energy and the total fluid potential energy. For multidomain systems, such as electromechanical systems, the required energy and co-energy functions follow by addition. Definitions, details, and some historical facts on the relevant energies and co-energies for the various engineering domains are discussed in "State Functions."

The Lagrangian equations constitute a system of second-order differential equations, which can be transformed into a system of first-order differential equations, called the Hamiltonian equations, by performing a coordinate transformation to express the dynamics in terms of alternative physical variables. For instance, in the mechanical domain the velocities are transformed into their associated momenta. The Hamiltonian equations are generated from the *Hamiltonian*, which, instead of the difference between the kinetic co-energy and the potential energy, is defined to be the *sum* of the total kinetic energy and the total potential energy. For electrical networks, the Hamiltonian is the sum of the total stored magnetic energy and the electric energy.

Similar to kinetic energy and kinetic co-energy, potential energy and potential co-energy can be defined. The potential energy is defined as the integral of the force with respect to the displacement, whereas the complementary potential energy, called the *potential co-energy*, is defined as the integral of the displacement with respect to the force. The same duality holds in the fluid domain, as well as in the electrical domain, where electric co-energy is defined as the integral of the capacitor charge with respect to the voltage. Other types of duality can be found at the levels of variables, elements, and conservation laws. Dual variables and elements include current and voltage, force and velocity, inductance and capacitance, and inertia and stiffness. An example of dual conservation laws is given by the relationship between Kirchhoff's current and voltage laws.

Similar to the duality between energy and co-energy, it is also possible to define a dual, or complementary in the sense of the energies, Lagrangian formulation, which gives rise to the co-Lagrangian equations. The main difference between the Lagrangian and co-Lagrangian equations is the type of variables used in the description. For instance, in the electrical domain, the co-Lagrangian is defined to be the

difference between the total electric co-energy and the total magnetic energy. Consequently, the co-Lagrangian is expressed in terms of voltages and flux linkages, instead of currents and charges. Similarly, for mechanical systems, the co-Lagrangian is defined to be the difference between the total potential co-energy and the total kinetic energy and hence is expressed in terms of forces and momenta instead of velocities and displacements.

In the context of mechanical systems, the application and usefulness of the co-Lagrangian equations is limited. First, most mechanical systems can be described by Lagrangian and Hamiltonian equations. Second, the effect of gravity, which can be included in the Lagrangian equations, cannot be captured by a potential co-energy function since the relationship between gravitational force and its associated displacement is not globally invertible. In other words, we cannot define the integral of the displacement with respect to the gravitational force. However, in other engineering domains, the co-Lagrangian formulation is often useful—and sometimes even necessary—to describe the dynamics in an energy-based manner. Some examples of networks and systems that cannot be described by a Lagrangian, but do allow a co-Lagrangian description, are discussed in the section "Limitations and Generalizations." The dual form of the Hamiltonian formulation is given by the co-Hamiltonian equations. The corresponding co-Hamiltonian equals the total stored co-energy. For the mechanical and electrical domains, the form of the Lagrangian and Hamiltonian, as well as their complements, the co-Lagrangian and co-Hamiltonian, are summarized in Table 1.

Apart from energy storage, all physical systems are subject to energy dissipation and external energy sources. Consequently, any practical usage of the Lagrangian and Hamiltonian frameworks, or their dual forms, must include these phenomena. Although independent energy sources can usually be included through an energy function, such as the gravitational force through the gravitational potential energy, the constitutive relationships of dissipative elements must be modeled in terms of power. Even though energy and power are often used interchangeably in common speech, they are of course different quantities; specifically, power is the change of energy per unit time. For linear mechanical dissipation a *Rayleigh dissipation function* is defined [16], [17]. The value of this function has the units of power given by the product of force and velocity. For nonlinear mechanical dissipation as well as dissipation in other engineering domains, the *content* and *co-content* functions

**TABLE 1** Forms of the Lagrangian and Hamiltonian, and their complements, the co-Lagrangian and co-Hamiltonian, for the mechanical and electrical domain.

Domain	Lagrangian	Hamiltonian	Co-Lagrangian	Co-Hamiltonian
Mechanical	Kinetic co-energy	Kinetic energy	Potential co-energy	Potential co-energy
	–	+	–	+
	Potential energy	Potential energy	Kinetic energy	Kinetic co-energy
Electrical	Magnetic co-energy	Magnetic energy	Electric co-energy	Electric co-energy
	–	+	–	+
	Electric energy	Electric energy	Magnetic energy	Magnetic co-energy

are defined [18], where the adjective “co-” refers to the complementary form of the content function. The values of these functions have units of power as well. For instance, in the electrical domain the content and co-content functions involve products of voltage and current, whereas, in the fluid domain, the content and co-content involve products of pressure and volume flow. Such content and co-content functions are called power functions.

Although the Lagrangian and co-Lagrangian frameworks allow for a reasonably large class of nonlinear dissipative elements, their application may be limited since both frameworks reflect dual properties of the system. For instance, in comparison to the duality of Kirchhoff’s current and voltage laws, the Lagrangian formulation of an electrical network explicitly captures Kirchhoff’s voltage laws, while the current laws are hidden in the definition of the configuration coordinates. Dually, in the co-Lagrangian formulation the appearance of the voltage and current laws is reversed. While for mechanical systems it is sufficient to describe only the resultant of the forces in terms of generalized displacements and velocities, for an electrical system the dissipative elements or sources can be such that either a Lagrangian or a co-Lagrangian formulation alone may not be sufficient. In these cases it is necessary to establish combinations of the Lagrangian and co-Lagrangian formulations. In the context of electrical networks, this combination gives rise to the Brayton-Moser (BM) equations stemming from the early 1960s [19], [20]. The BM equations rely on the existence of a function called the mixed-potential function. This function consists of the difference between the content and co-content functions plus an additional term that reflects the instantaneous power transfer between the subsystems. Consequently, the mixed-potential is a power function, which justifies referring to the BM equations as a power-based modeling framework. Besides providing a compact system description, the mixed-potential function is useful for determining stability criteria for nonlinear electrical networks, especially those containing regions of negative resistance.

The purpose of this article is to provide an overview of both the energy- and power-based modeling frameworks and to discuss their mutual relationships. Furthermore, the BM equations are shown to be applicable to a large class of nonlinear physical systems, including lumped-parameter

mechanical, fluid, thermal, and electromechanical systems. Systems containing switches, such as electrical power converters and mechanical systems with impacts, are also discussed. The application to distributed-parameter systems is illustrated using two examples, namely, a mechanical system and Maxwell’s equations. Finally, a few applications of the power-based framework are highlighted.

## ENERGY-BASED MODELING OF PHYSICAL SYSTEMS

To set up the Lagrangian and Hamiltonian frameworks, as well as the power-based framework, in a sufficiently generic manner, we adopt the signal analogies used in multi-domain physical modeling disciplines such as bond graph modeling [21]. The various signals are then reduced to a set of four basic variables called the *efforts*  $e$ , the *flows*  $f$ , the *generalized momenta*  $p$ , and the *generalized displacements*  $q$ , where

$$p(t) = p(t_0) + \int_{t_0}^t e(\tau) d\tau \quad (2)$$

and

$$q(t) = q(t_0) + \int_{t_0}^t f(\tau) d\tau, \quad (3)$$

respectively. The four basic variables within each physical domain are summarized in Table 2. The analogy between the mechanical and electrical domains is the classical *force-voltage* or *mass-inductance* analogy; see “Analogues, Duals, and Dialogues.”

### The Four-Element Quadrangle

Since the variables  $e$  and  $p$  are related by (2), or equivalently,  $\dot{p} = e$ , and the variables  $f$  and  $q$  are related by (3), or equivalently,  $\dot{q} = f$ , there exist four distinct pairwise combinations  $(p, f)$ ,  $(q, e)$ ,  $(f, e)$ , and  $(q, p)$  that lead to the following classification of generalized system elements, *inductive* elements (including mechanical masses and electrical inductors), *capacitive* elements (including mechanical springs and electrical capacitors), *resistive* elements (including mechanical dampers and electrical resistors), and *memristive* elements. The memristive element has its origin in the electrical domain [22] as the



## Analogues, Duals, and Dialogues

In science and engineering, the ideas and concepts developed in one branch of science and engineering are often transferred to other branches. One approach to transferring these ideas and concepts is by the use of *analogies*. Historically, the first attempt to relate mechanical and electrical systems was due to James Clerk Maxwell and Lord Kelvin in the 19th century by using the similarity between force and voltage, as is also apparent from the early use of the term electromotive force (emf). This *force-voltage* (sometimes called *classical*) analogy implies that a mechanical mass is analogous to an electrical inductor. In addition to the analogy between mechanical and electrical systems, it was observed that phenomena from other physical domains exhibit similar properties, as summarized in Table 2.

Once the force-voltage analogy had been established, some scientists started to address some of its limitations. These limitations led to the alternative *force-current* analogy, which implies that a mechanical mass is analogous to an electrical capacitor. The force-current (sometimes called *mobility*) analogy can be traced back to Darriues (1929), although it appears to have been discovered independently a few years later by Hähnle (1932) and Firestone (1933) [S5]. From a mathematical perspective it seems pointless to discuss which analogy—when it exists—is superior, since both analogies lead to equally valid and self-consistent descriptions of physical systems. Arguments in favor of the force-current analogy are mainly related to the preservation of the structural and topological resemblance. However, from a physical perspective, one of the main arguments in favor of the force-voltage analogy is the analogy between force and pressure (for the force-current analogy, pressure is considered equivalent to velocity). Furthermore, both current and velocity include

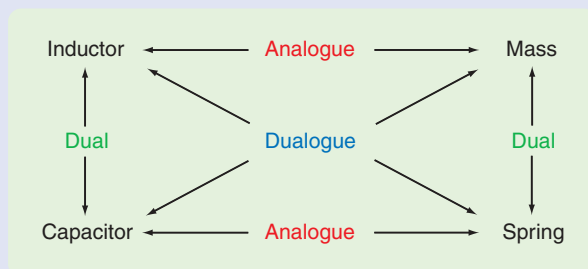

**FIGURE S2** Electrical versus mechanical. Based on the force-voltage analogy, a mechanical mass is the analogue of an electrical inductor. Likewise, a mechanical spring is the analogue of an electrical capacitor. Mass and spring elements are complementary or dual elements. The same duality holds for other inductive and capacitive elements, or flow-controlled and effort-controlled resistive elements. Furthermore, an analogue of a dual element is called a dialogue, as illustrated by the diagonal lines. For instance, an electrical inductor is the dialogue of a mechanical spring. The force-current, or mobility analogy, is the dialogue of the force-voltage analogy.

information about the direction in which energy is exchanged within the system, whereas neither voltage nor force include this information. For this reason it is natural to consider current and velocity as flow variables. Although the contribution of the present article does not depend on the type of analogy used, the force-voltage analogy is the one considered here. For further discussions on the force-voltage versus force-current analogy, see [S6], [S7], and [3]. A fairly extensive overview regarding the conception and evolution of both analogies is given in [S5].

Another closely related concept is the principle of *duality*. Examples of dual variables and elements are voltage and current, force and velocity, inductance and capacitance, and mass and stiffness. The various properties for mechanical and electrical systems are depicted in Figure S2. For a similar diagram in the context of the force-current analogy, see [3]. An analogue of a dual phenomenon is called a *dialogue*. Hence, the force-voltage analogue is the dialogue of the force-current analogue, and vice versa.

In constructing analogies between mechanical and electrical systems it is important to realize that the kinetic energy of a mass is determined relative to an inertial reference frame [S8]. The force-voltage analogy therefore suggests that the true electrical analogue of a mass is an inductor whose energy can be determined relative to a single current. Using the force-current analogy, the true electrical analogue of a mass is a grounded capacitor. Hence, to obtain a true mechanical analogue of an electrical circuit with inductors that allow their currents to be expressed in terms of more than one loop current, or with ungrounded capacitors in case of the force-current analogy, a mechanical element called the *inertor* is required [S7]. The inertor differs from a conventional mass element since it has two independent terminals, which eliminates the need for a reference frame. The inertor constitutes the dual of a mechanical spring, which also has two independent terminals, and constitutes the mechanical analogue of an inductor, or a capacitor in case of the force-current analogy. These analogues allow electrical circuits to be translated over to mechanical systems in an unambiguous manner.

## REFERENCES

- [S5] P. Gardonio and M. J. Brennan, "On the origins and development of mobility and impedance methods in structural dynamics," *J. Sound Vib.*, vol. 249, no. 3, pp. 557–573, 2002.
- [S6] N. J. Hogan and P. C. Breedveld, "The physical basis of analogies in network models of physical system dynamics," in *Proc. 1999 Int. Conf. Bond Graph Modeling and Simulation (ICBGM'99) Western Multiconf.*, Simulation Series, no. 1, Jan. 1999, vol. 31, pp. 96–104.
- [S7] M. C. Smith, "Synthesis of mechanical networks: The inertor," *IEEE Trans. Automat. Contr.*, vol. 47, no. 10, pp. 1648–1662, Oct. 2002.
- [S8] D. S. Bernstein, "Newton's frames," *IEEE Control. Syst. Mag.*, vol. 28, no. 1, pp. 17–18, Feb. 2008.

**TABLE 2 Domains and variables.**

	<b>Effort <math>e</math></b>	<b>Flow <math>f</math></b>	<b>Generalized Displacement <math>q</math></b>	<b>Generalized Momentum <math>p</math></b>
Electric	Voltage $V$ [V]	Current $I$ [A]	Charge $q$ [C]	Flux linkage $\phi$ [V-s]
Translation	Force $F$ [N]	Velocity $v$ [m/s]	Displacement $x$ [m]	Momentum $p$ [N-s]
Rotation	Torque $\tau$ [N-m]	Angular velocity $\omega$ [rad/s]	Angular displacement $\theta$ [rad]	Angular momentum $b$ [N-m-s]
Fluid	Pressure $P$ [N/m <sup>2</sup> ]	Volume flow $Q$ [m <sup>3</sup> /s]	Volume $V$ [m <sup>3</sup> ]	Pressure momentum $\Gamma$ [N-s/m <sup>2</sup> ]
Thermodynamic	Temperature $T$ [K]	Entropy flow $f_s$ [W/K]	Entropy $S$ [J/K]	—

missing element that constitutes a relationship between charge and flux linkage. An electrical passive two-terminal memristive device was not constructed until recently [23]. An example of a mechanical memristor is the tapered dashpot, which is a mechanical damper whose resistance depends on the displacement of its terminals; see “The Memristor.” In a generalized context, the memristive element establishes the relationship between  $q$  and  $p$ , and hence fills the gap in the *four-element quadrangle* shown in Figure 2. The associated constitutive relationships and related properties of the four basic elements are discussed in “State Functions.”

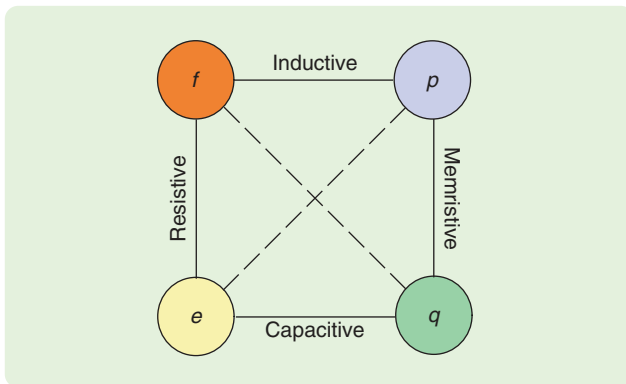

**FIGURE 2** The four-element quadrangle. An inductive element corresponds to a static relationship between flow  $f$  and generalized momentum  $p$ ; a capacitive element corresponds to a static relationship between effort  $e$  and generalized displacement  $q$ ; and a resistive element corresponds to a static relationship between flow and effort. The fourth relationship, between generalized momentum and generalized displacement, defines a memristive element. The dynamic relationships are represented by the dashed diagonal lines. Examples of inductive elements include a mechanical mass  $M$  described by  $p = Mv$ , where  $p$  and  $v$  denote its momentum and velocity, respectively (see Table 2), or a linear electrical inductor, with inductance  $L$ , described by  $\phi = LI$ , where  $\phi$  and  $I$  denote its associated flux linkage and current, respectively. The corresponding dynamic relationships are given by  $\dot{p} = F$  (Newton’s second law) and  $\dot{\phi} = V$  (Faraday’s law). Examples of capacitive elements include a linear mechanical spring with spring constant  $K$ , described by  $F = Kx$  (Hooke’s law), where  $x$  and  $F$  denote its displacement and force, or an electrical capacitor, with capacitance  $C$ , described by  $q = CV$ , where  $q$  and  $V$  denote its associated charge and voltage, respectively. For these examples the corresponding dynamical relationships are  $\dot{x} = v$  and  $\dot{q} = I$ , respectively. Examples of resistive relationships are Ohm’s law  $V = RI$ , with resistance  $R$ , or its mechanical analog  $F = Rv$ , where  $R$  is the coefficient of friction. The electrical memristor is discussed in “The Memristor,” while the general nonlinear versions of the four generic elements are discussed in “State Functions.”

The set of basic variables can be subdivided further into *power variables* and *energy variables*. The power variables are the efforts and flows since their product equals power [21], that is,

$$P(t) = e(t)f(t). \quad (4)$$

The time integral of power equals energy

$$E(t) = E(t_0) + \int_{t_0}^t e(\tau)f(\tau)d\tau, \quad (5)$$

where  $E(t_0)$  denotes the energy at initial time  $t_0$ . Substituting  $dp(\tau) = e(\tau)d\tau$  or  $dq(\tau) = f(\tau)d\tau$  into (5) yields either a line integral that represents the energy stored by an inductive element or by a capacitive element, respectively. For

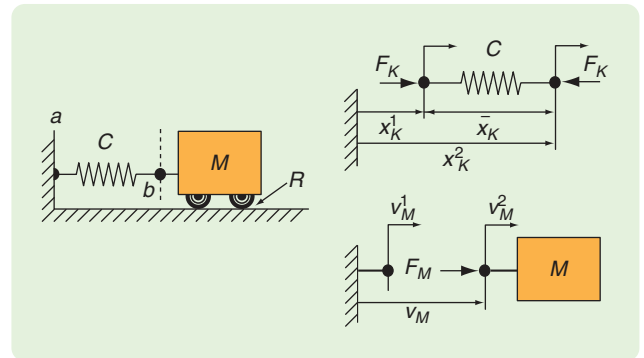

**FIGURE 3** Mass-spring system. This translational mechanical system consists of a rigid interconnection of a cart with constant mass  $M$  and an ideal linear spring with compliance  $C$  and natural unstretched length  $\bar{x}_K$ . The motion is restricted to be parallel to the horizontal axis and relative to a point in a reference frame called ground. The endpoints of the spring are called terminals (or nodes). The relative displacement of the spring is determined by the difference between the terminal displacements, that is,  $x_K = x_K^2 - x_K^1 - \bar{x}_K$ . The terminal displacements  $x_K^1$  and  $x_K^2$  are both measured with respect to the same ground. Since both sides of the mass are moving with the same velocity, one terminal is associated with the velocity of its center of gravity, while the other terminal is the velocity of the datum or ground. Hence, the relative velocity of the mass equals  $v_M = v_M^2 - v_M^1$ , with  $v_M^1 = 0$ . If the interconnection constraint of the mass and the spring is determined by equating their positions at point  $b$ , as advocated in [41], we first need to choose a ground, for instance, the wall on the left (point  $a$ ). Consequently,  $x_K^1 = 0$  so that the position of the mass is determined by  $x_M = x_K + \bar{x}_K$ . The offset of the mass, which is determined by only the natural length of the spring, coincides with the spurious constant discussed in [41]. This offset can be eliminated by shifting the reference to point  $b$ . Additionally, in a practical situation the cart is subject to friction forces acting on the wheels. These effects are often modeled by a resistive element with resistance  $R$ .

this reason, the generalized momenta and displacements are often referred to as energy variables. For further details, see “State Functions.”

To distinguish between the variables associated with each of the four elements, the variables  $e, f, q,$  and  $p$  are given a subscript from the set  $\{r, \ell, c, m\}$ , referring to resistive, inductive, capacitive, and memristive elements, respectively.

### Example 1: A Mechanical Mass-Spring System

To illustrate the classification presented above, consider the translational mechanical system depicted in Figure 3. This system consists of the interconnection of a mass  $M > 0$  and a linear spring with spring constant  $K = C^{-1}$ , where  $C > 0$  is the compliance. The mass defines the relationship between its momentum  $p_M$  and its velocity  $v_M$ , which can be expressed as either  $p_M = Mv_M$ , or  $v_M = M^{-1}p_M$ . Similarly, the spring defines the relationship between its elongation  $x_K$  and the associated force  $F_K$ , which in the linear case can be expressed as either  $F_K = Kx_K$  (Hooke’s law) or  $x_K = CF_K$ .

For a nonlinear spring, these relationships are expressed as either  $F_K = \hat{F}_K(x_K)$  or  $x_K = \hat{x}_K(F_K)$ , referring to a displacement-controlled or a force-controlled spring, respectively. Note that the mass belongs to the class of inductive elements, while the spring belongs to the class of capacitive elements. According to Table 2, the variables  $p_M$  and  $v_M$  correspond to generalized momentum and flow, respectively, whereas  $x_K$  and  $F_K$  correspond to generalized displacement and effort, respectively. The corresponding dynamical relationships are defined by  $\dot{p}_M = F_M$  and  $\dot{x}_K = v_K$ , where  $F_M$  and  $v_K$  are the force and the velocity associated with the mass and the spring, respectively. Furthermore, if the mass is subject to viscous friction, with damping coefficient  $R$ , then, in addition,  $F_R = Rv_R$  (mechanical version of Ohm’s law), where  $F_R$  and  $v_R$  are the force (effort) and velocity (flow) associated with the friction, respectively. The effect of nonlinear friction is expressed either in terms of  $F_R = \hat{F}_R(v_R)$ , referring to velocity-controlled friction, or  $v_R = \hat{v}_R(F_R)$ , referring to force-controlled friction. ■

## The Memristor

Since electronics was developed, engineers designed circuits using combinations of three basic two-terminal elements, namely, resistors, inductors, and capacitors. From a mathematical perspective, the behavior of each of these elements, whether linear or nonlinear, is described by relationships between two of the four basic electrical variables, namely, voltage, current, charge, and flux linkage. A resistor is

described by a relationship between current and voltage; a capacitor by that of voltage and charge; and an inductor by that of current and flux linkage. But what about the relationship between charge and flux linkage? As pointed out in [22], a fourth element must be added to complete the symmetry. This “missing element” is called the *memristor*, whose name is a contraction of memory and resistance and refers to a resistor with memory. The memory aspect stems from the fact that a memristor “remembers” the amount of current that has passed through it together with the total applied voltage. More specifically, letting  $q$  denote the charge and  $\phi$  denote the flux linkage, a two-terminal *charge-controlled* memristor is defined by the constitutive relationship

$$\phi = \hat{\phi}(q).$$

Since flux linkage is the time integral of voltage  $V$  and charge is the time integral of current  $I$ , that is,  $V = \dot{\phi}$  and  $I = \dot{q}$ , we obtain

$$V = M(q)I, \tag{S9}$$

where  $M(q) := d\hat{\phi}(q)/dq$  is the *incremental memristance*. Similarly, a two-terminal *flux-controlled* memristor (memductor) is defined by

$$q = \hat{q}(\phi).$$

Differentiating the latter yields the dual of (S9), namely,

$$I = W(\phi)V, \tag{S10}$$

where  $W(\phi) := d\hat{q}(\phi)/d\phi$  is the *incremental memductance*. The four basic electrical elements are summarized in Figure S2.

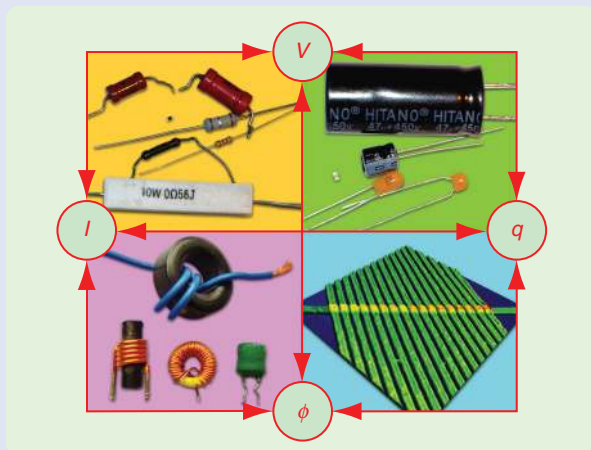

FIGURE S3 The four-element quadrangle for the electrical domain. As indicated by the arrows, an inductor corresponds to a static relationship between current  $I$  and flux linkage  $\phi$ , a capacitor corresponds to a static relationship between voltage  $V$  and electric charge  $q$ , and a resistive element corresponds to a static relationship between current and voltage. The fourth relationship, between  $\phi$  and  $q$ , defines a memristor. In the last case the variables  $\phi$  and  $q$  do not necessarily have the interpretation of a physical flux or charge and therefore must be considered as integrated voltage or current, respectively.

## Classical Energy-Based Framework

For ease of presentation, we begin by considering a class of systems consisting solely of interconnected inductive and capacitive energy-storage elements; see Table 3 for the energy stored in the elements of various engineering domains. The equations of motion can be deduced from the dynamic relationships associated with the elements together with a set of constraint relationships that define how the elements are interconnected to form the overall system. In “State Functions,” particular energy functions are associated with the inductive and capacitive elements. These functions are given in terms of the individual element variables, but we may equally well employ any other set of variables that uniquely define the

TABLE 3 Domains and energy.

Domain	Inductive Energy $\mathcal{T}$ or Co-Energy $\mathcal{T}^*$	Capacitive Energy $\mathcal{V}$ or Co-Energy $\mathcal{V}^*$
Electric	Magnetic (inductor)	Electric (capacitor)
Translation	Kinetic (mass)	Potential (spring, gravity)
Rotation	Kinetic (inertia)	Potential (rotational spring)
Fluid	Kinetic (tube, pipeline)	Potential (tank)
Thermodynamic	—	(Heating)

configuration of the system, and thus of every element. Any such set of variables is called a *complete set of generalized coordinates*. The number of *degrees of freedom* of the system is the number of independent coordinates required to specify the configuration of each element in the system.

Suppose that a system configuration with  $n$  degrees of freedom can be described by the complete set of generalized displacement coordinates  $q = \text{col}(q_1, \dots, q_n)$ . The Lagrangian

Observe that (S9) and (S10) are generalized versions of Ohm’s law, in which the memristor and memductor are acting as charge- and flux-modulated resistors, respectively. It is important to realize that, for the special cases in which the constitutive relations are linear, that is, when the incremental memristance  $M(q)$  or the incremental memductance  $W(\phi)$  is constant, a memristor and a memductor become an ordinary resistor and conductor. Hence, memristors and memductors are relevant only in nonlinear circuits.

To gain intuition for what distinguishes a memristor from a resistor as well as from an inductor and a capacitor, let us briefly consider the common analogy of a resistor and a pipe that carries a fluid. The fluid can be considered analogous to charge, the pressure at the input of the pipe is similar to voltage, and the rate of flow of the fluid through the pipe is like current. As in the case of a resistor, the flow of fluid through the pipe is faster if the pipe is shorter or if it has a larger diameter. Now, an analogy for a memristor is a flexible pipe that expands or shrinks according to how fluid flows through it. If fluid flows through the pipe in one direction, the diameter of the pipe increases, thus enabling the fluid to flow faster. If fluid flows through the pipe in the opposite direction, however, the diameter of the pipe decreases, thus slowing down the flow of the fluid. If the fluid pressure is turned off, the pipe retains its most recent diameter until the fluid pressure is turned back on. Unlike a bucket (or a capacitor) a memristive pipe does not store the fluid but “remembers” how much fluid flowed through it.

A physical electrical passive two-terminal memristive device was constructed only recently when scientists at Hewlett-Packard Laboratories announced its realization. In particular, it is shown in [23] that memristance naturally arises in nanoscale systems when electronic and atomic transport are coupled under an external bias voltage. The memristive effect is realized

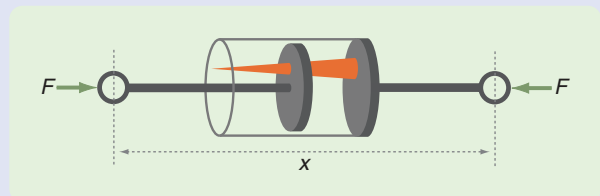

FIGURE S4 Example of a tapered dashpot. The friction coefficient depends on the displacement  $x$ . In practice the taper is achieved by a conical pin passing through an orifice in the piston. The shape of the pin can be machined to produce any desired memristive relation between displacement and momentum.

by fabricating a layered platinum-titanium-oxide-platinum nano-cell device.

It will be interesting to see what applications arise for this device and whether it invokes a revival of network theory. On the other hand, as pointed out in [43], in the mechanical domain, the tapered dashpot is a mechanical damper whose resistance depends on the displacement of its terminals; see Figure S4. In practice the taper is achieved by a conical pin passing through an orifice in the piston. The shape of the pin can be machined to produce a desired memristive relation between displacement and momentum, which are the mechanical analogies of charge and flux linkages. Other examples of engineering systems in which the memristor phenomena is apparent can be found in [S9], [43], and [45]. An extension of the concept to a much broader class of systems, called *memristive systems*, is presented in [S10].

## REFERENCES

- [S9] L. O. Chua, “Device modeling via basic nonlinear circuit elements,” *IEEE Trans. Circuits Syst.*, vol. CAS-27, no. 11, pp. 1014–1044, Nov. 1980.
- [S10] L. O. Chua and S. M. Kang, “Memristive devices and systems,” *Proc. IEEE*, vol. 64, pp. 209–223, 1976.

equations of motion are given by (see “Notation” for the notation of partial derivatives)

$$\frac{d}{dt} \nabla_f \mathcal{L}(q, f) - \nabla_q \mathcal{L}(q, f) = 0, \quad (6)$$

where the flow variables  $f = \dot{q}$ , with  $f = \text{col}(f_1, \dots, f_n)$ , are called generalized velocities. Furthermore, the Lagrangian  $\mathcal{L}(q, f)$  is defined by

$$\mathcal{L}(q, f) = T^*(f) - \mathcal{V}(q),$$

where  $T^*(f)$  represents the total inductive co-energy and  $\mathcal{V}(q)$  the total capacitive energy, which are obtained as the sums of the inductive co-energies and the capacitive energies in the constituent elements, respectively. See “State Functions” for details on energy and co-energy.

The Lagrangian equations (6), in both the linear and non-linear cases, can be derived in various ways. Perhaps the best known methods are the derivations based on d’Alembert’s principle and the principle of virtual work as well as derivations originating in variational methods such as Hamilton’s principle [1], [17]. Alternative methods can be found in [24]. Furthermore, the Lagrangian equations (6) define a set of  $n$  second-order differential equations that constitute an effort balance, and the information necessary to describe the system’s dynamic behavior is solely contained in the Lagrangian.

The Hamiltonian equations are established by considering the Legendre transformation. We thus define the generalized momenta  $p = \nabla_f \mathcal{L}(q, f)$ , with  $p = \text{col}(p_1, \dots, p_n)$ . Then, under the assumption that  $f$  can be expressed in terms of  $p$ , the set of  $n$  second-order equations (6) can be transformed into  $2n$  first-order equations of the form

$$\dot{q} = \nabla_p \mathcal{H}(q, p), \quad (7)$$

$$\dot{p} = -\nabla_q \mathcal{H}(q, p), \quad (8)$$

where the Hamiltonian  $\mathcal{H}$  is the total stored energy, that is,

$$\mathcal{H}(q, p) = T(p) + \mathcal{V}(q).$$

## Notation

Let

$$x = \begin{bmatrix} x_1 \\ \vdots \\ x_n \end{bmatrix} = \text{col}(x_1, \dots, x_n) \in \mathbb{R}^n$$

denote a column vector, and let  $\mathcal{V}(x)$  denote a scalar function  $\mathcal{V}: \mathbb{R}^n \rightarrow \mathbb{R}$ . The gradient of  $\mathcal{V}(x)$  with respect to  $x$  is denoted by

$$\nabla_x \mathcal{V}(x) = \text{col} \left( \frac{\partial \mathcal{V}}{\partial x_1}(x), \dots, \frac{\partial \mathcal{V}}{\partial x_n}(x) \right) \in \mathbb{R}^n.$$

Furthermore, the notation  $\nabla_x^2 \mathcal{V}(x) \in \mathbb{R}^{n \times n}$  denotes the Hessian matrix.

The Hamiltonian equations (7) and (8) constitute both a flow and effort balance, respectively. Note that, like (6), the system configuration in (7), (8) is still described in terms of the generalized displacement coordinates  $q$ .

## Example 1 Revisited: The Lagrangian and Hamiltonian Equations

For the mechanical system of Figure 3, assume that the mass moves without friction. In deriving the Lagrangian equations we need only the kinetic (inductive) co-energy associated with the mass and the potential (capacitive) energy stored in the spring. According to the definitions given in “State Functions,” the kinetic co-energy is determined by

$$T^*(v_M) = \frac{M}{2} v_M^2,$$

whereas the potential energy is given by

$$\mathcal{V}(x_K) = \frac{x_K^2}{2C}.$$

The next step is to define the system configuration. Since the system has one degree of freedom, a natural choice is to take the displacement of the point  $b$  in Figure 3, that is,  $x = x_K = x_M$ . With this choice, the Lagrangian is defined by

$$\mathcal{L}(x, v) = \frac{M}{2} v^2 - \frac{x^2}{2C}, \quad (9)$$

with corresponding velocity  $v = \dot{x}$ . Substituting (9) into the Lagrange equation (6) yields the second-order differential equation

$$M\ddot{x} + \frac{x}{C} = 0. \quad (10)$$

Concerning the Hamiltonian counterpart, we first define the momentum

$$p = \nabla_v \mathcal{L}(x, v) = Mv,$$

and introduce the Hamiltonian

$$\mathcal{H}(x, p) = [pv - \mathcal{L}(x, v)]_{v=\frac{p}{M}} = \frac{p^2}{2M} + \frac{x^2}{2C}.$$

Hence, according to (7) and (8), the Hamiltonian equations for the system are given by

$$\dot{x} = \frac{p}{M}, \quad \dot{p} = -\frac{x}{C}. \quad (11)$$

Note that the Lagrangian equation (10) equates only the forces of the mass and the spring, whereas the Hamiltonian equations (11) equates both the velocities and the forces in terms of  $x$  and  $p$ . Furthermore, if in Figure 3 the point  $a$  is chosen as the point of reference, the potential energy needs to be modified as

$$\mathcal{V}(x) = \frac{(x - \bar{x}_K)^2}{2C},$$

where  $\bar{x}_K$  is the relaxed length of the spring. ■

The Lagrangian equations of motion (6) and the Hamiltonian equations (7), (8) are represented in Figure 4 (solid lines). The diagram suggests that there exists a dual form of the Lagrangian equations of motion (6) if the system can be expressed in terms of a set of generalized momentum coordinates and their time-derivatives. The dynamics in terms of the generalized momenta and efforts is called a *co-Lagrangian* system. This system is obtained by replacing the Lagrangian  $\mathcal{L}(q, \dot{q})$  in (6) by its complementary or dual form, called the *co-Lagrangian*, defined by the difference between the total capacitive co-energy and the total inductive energy, that is,

$$\mathcal{L}^*(p, e) = \mathcal{V}^*(e) - \mathcal{T}(p).$$

Hence, the co-Lagrangian equations of motion take the form

$$\frac{d}{dt} \nabla_e \mathcal{L}^*(p, e) - \nabla_p \mathcal{L}^*(p, e) = 0, \quad (12)$$

where the efforts  $e = \dot{p}$ , with  $e = \text{col}(e_1, \dots, e_n)$ , are generalized force coordinates. Note that (12) again defines a set of  $n$  second-order differential equations, but now constitutes a flow balance.

### Example 1 Revisited: The Co-Lagrangian Equations

For the mass-spring system of Figure 3, the formulation of the co-Lagrangian means that instead of taking the displacement of the connection point as the system configuration, a suitable momentum variable must be chosen. One possible choice is  $p = -p_M = p_K$ , where the minus sign stems from the reference direction of the mass and spring forces. Consequently,  $F = \dot{p} = F_K$ , and the co-Lagrangian has the form

$$\mathcal{L}(p, F) = \frac{C}{2} F^2 - \frac{p^2}{2M},$$

which upon substitution into (12) yields the second-order differential equation

$$C\dot{F} + \frac{p}{M} = 0. \quad (13)$$

Note that (13) equates the velocities of the spring and mass with  $v_M = -M^{-1}p$ . ■

The three representations considered above describe the dynamics of a system consisting only of inductive and capacitive elements. The underlying principle of the transformations between the various energy functions is the existence of the associated Legendre transformations. The diagram in Figure 4 shows that there exists a fourth equation set involving the variables  $e$  and  $f$ . Starting from the Hamiltonian equations, the Legendre transformation of both  $q \mapsto e$  and  $p \mapsto f$  is considered simultaneously, that is,

$$\mathcal{H}^*(f, e) = q^\top e + p^\top f - \mathcal{H}(q, p),$$

where it is assumed that  $q$  can be expressed in terms of  $e$ , and  $p$  can be expressed in terms of  $f$ , that is, if the respective relationships  $e = \nabla_q \mathcal{H}(q, p) = \nabla_q \mathcal{V}(q)$  and  $f = \nabla_p \mathcal{H}(q, p) = \nabla_p \mathcal{T}(p)$  are invertible. Thus the *co-Hamiltonian* is given by

$$\mathcal{H}^*(f, e) = \mathcal{T}^*(f) + \mathcal{V}^*(e),$$

where  $\mathcal{T}^*(f)$  represents the total inductive co-energy and  $\mathcal{V}^*(e)$  is the total capacitive co-energy. It is evident from Figure 4 that the co-Hamiltonian equations relate in a cross-wise differential manner, in the sense that  $\dot{p} = e$  and  $\dot{q} = f$ , as visualized by the diagonal lines, with the Hamiltonian equations. Hence, the co-Hamiltonian equations are given by

$$\frac{d}{dt} \nabla_f \mathcal{H}^*(f, e) = e, \quad -\frac{d}{dt} \nabla_e \mathcal{H}^*(f, e) = f. \quad (14)$$

The latter set of equations completes the quadrangle in Figure 4.

### Example 1 Revisited: The Co-Hamiltonian Equations

Returning to the mass-spring system of Figure 3, the co-Hamiltonian takes the form

$$\mathcal{H}^*(v, F) = \frac{C}{2} F^2 + \frac{M}{2} v^2, \quad (15)$$

which upon substitution into (14) yields the first-order differential equations

$$M\dot{v} = F, \quad -C\dot{F} = v. \quad (16)$$

Taking the system configuration of “Example 1 Revisited: The Co-Lagrangian Equations” as a reference, the spring force is

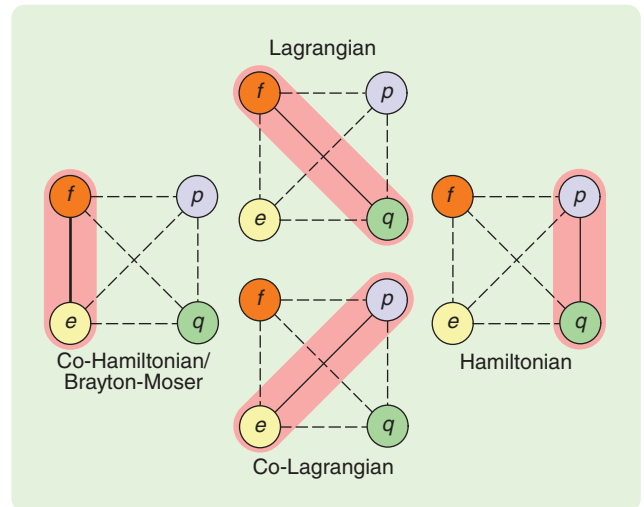

**FIGURE 4** Relationship between the Lagrangian and Hamiltonian equations and their complementary versions. The Lagrangian equations are described in terms of generalized displacements and their corresponding flows (generalized velocities). The associated Hamiltonian equations are obtained by replacing the flows by generalized momenta. The complementary or dual Lagrangian equations are referred to as the co-Lagrangian equations since they are described in terms of dual variables, namely, a set of generalized momenta and its associated efforts (generalized forces). The complementary Hamiltonian formulation is represented by the co-Hamiltonian equations, which are described in terms of flows and effort. The co-Hamiltonian formulation coincides with the Brayton-Moser equations.

given by  $F_K = F$ , while the velocity of the mass equals  $v_M = -v$ . The co-Hamiltonian representation (16) provides both the force and velocity balance, but now in terms of force (effort) and velocity (flow) variables only. The original system configuration variables  $x$  and  $p$  are eliminated from the model. ■

### Including Resistive Elements

The frameworks considered above assume that the system is free from dissipation and externally supplied efforts or flows. Dissipation and supply effects can be included in the Lagrangian framework by introducing a content function  $\mathcal{D}(f)$ , (see "State Functions") so that (6) is modified as

$$\frac{d}{dt} \nabla_f \mathcal{L}(q, f) - \nabla_q \mathcal{L}(q, f) = -\nabla_f \mathcal{D}(f). \quad (17)$$

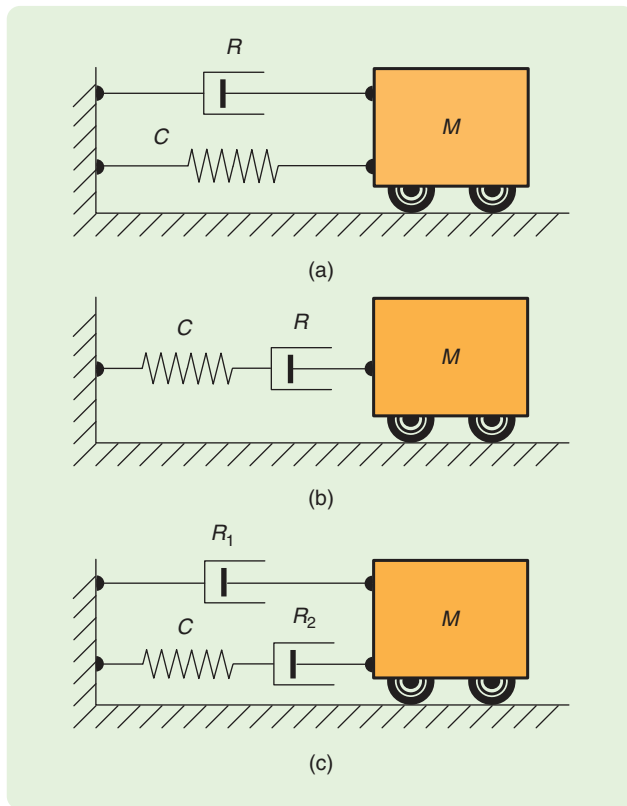

**FIGURE 5** Mass-spring-damper systems. (a) A mechanical system consisting of a constant mass  $M$  connected to a linear spring with compliance  $C$ , and a linear viscous damper with friction coefficient  $R$ . The damper can be modeled as a resistive element, which, at its terminals, exerts an equal and opposite force that is a function of the relative velocity between these terminals. Taking the wall on the left as the ground point, the relative velocity of the damper is determined by the velocity of the mass. This damper configuration is referred to as a velocity-controlled damper. In the case of (b), the same damper is placed between the mass and the spring. The relative velocity of the damper is now determined by the difference between the velocity of the mass and the spring. However, in deriving the state equations, the constitutive relationship of the damper is described rather as a function of its associated force. Dual to the configuration of (a), this damper configuration is referred to as force-controlled damper. (c) Combination of (a) and (b).

Note that the contents exist only for resistive elements that are flow-controlled. Effort-controlled resistive elements can be included in the Lagrangian framework if their constitutive relationships are one-to-one.

Similarly, the co-Lagrangian equations can be modified by introducing a resistive co-content function  $\mathcal{D}^*(e)$  associated to the effort-controlled resistive elements, so that (12) is modified as

$$\frac{d}{dt} \nabla_e \mathcal{L}^*(p, e) - \nabla_p \mathcal{L}^*(p, e) = -\nabla_e \mathcal{D}^*(e). \quad (18)$$

Flow-controlled elements can be included in the co-Lagrangian framework if their constitutive relationships are one-to-one. As illustrated in the examples below, the possibility of describing a system by either (17) or (18) strongly depends on the system configuration.

### Example 1 Revisited: Adding Dissipation

Suppose that the mass of the system of Figure 3 is subject to viscous friction with friction coefficient  $R$ . We know that the constitutive relationship can be represented by either  $F_R = Rv_R$  (flow-controlled with  $f = v_R$ ) or  $v_R = R^{-1}F_R$  (effort-controlled with  $e = F_R$ ). Since these relationships are linear, and thus one-to-one, the corresponding content and co-content functions exist. However, for the Lagrangian formulation only the content is needed, which, by noting that  $v_R = v$ , is given by

$$\mathcal{D}(v) = \int_0^v Rv_R dv_R = \frac{R}{2} v^2. \quad (19)$$

Hence the Lagrangian equation of motion for the lossless situation (10) is modified as

$$M\dot{v} + \frac{x}{C} = -\nabla_v \mathcal{D}(v) = -Rv. \quad (20)$$

### Example 2: Velocity- Versus Force-Controlled Damping

A similar, but conceptually different, situation occurs when a viscous damper is connected between the wall and the mass as shown in Figure 5(a). The corresponding content coincides with (19), and, since the velocity of the wall is considered to be zero as a reference velocity, we again have  $v_R = v$ . Hence, the system can be described by the same Lagrangian equation as derived in (20). On the other hand, a dual situation occurs if instead the damper is placed between the spring and the mass; see Figure 5(b). In this case the velocity of the damper cannot be related to the chosen velocity coordinate, but rather shares the force (effort) of the spring, that is,  $F_R = F$ . Hence, a direct way to describe the dynamics of this system is by means of the co-Lagrangian equation

$$C\dot{F} + \frac{p}{M} = -\nabla_F \mathcal{D}^*(F) = -\frac{F}{R}, \quad (21)$$

where the co-content  $\mathcal{D}^*(F)$  is of the form

$$\mathcal{D}^*(F) = \int_0^F \frac{F_R}{R} dF_R = \frac{F^2}{2R}. \quad (22)$$

Note that this configuration of the damper does not contribute a force to the Lagrangian equation of motion (20). ■

Example 2 shows that the Lagrangian and co-Lagrangian frameworks complement each other. Indeed, as shown in the section “The Brayton-Moser Equations,” both frameworks can be naturally combined into a single system of equations allowing for both effort- and flow-controlled resistive elements, as in the case of the system of Figure 5(c).

### Limitations and Generalizations

The Lagrangian and Hamiltonian equations, together with their dual formulations, the co-Lagrangian and co-Hamiltonian equations, respectively, introduced above are set up to explain the relations between the four frameworks in a straightforward manner. The two main assumptions that all four representations exist simultaneously are i) that the system configuration can be described by either a set of generalized displacement coordinates, or a set of generalized momentum coordinates, or both, all having the same dimension  $n$ , and ii) that the Legendre transformations from energy to co-energy, and vice versa, exist. While these assumptions are satisfied by some electrical networks that have the same number of inductive and capacitive elements, as well as some mechanical systems, such as the mass-spring example treated above, the class of systems that can be modeled by all four representations is restricted.

The main limitation in the mechanical domain concerns the existence of the potential co-energy function. If the constitutive relationship between force and displacement, say for a stiffness element  $K$ , is nonlinear, that is,  $F_K = \hat{F}_K(x_K)$ , it may be that its inverse  $x_K = \hat{x}_K(F_K)$  does not exist. In the absence of an inverse constitutive relationship it is not possible to evaluate the potential co-energy given by

$$\mathcal{V}^*(F) = \int_0^F \hat{x}_K(F_K) dF_K.$$

An example for which the potential co-energy cannot be evaluated, at least not globally, is in the case of systems that are subject to gravity; see “Example 3 Revisited.” However, for mechanical systems, the co-Lagrangian and co-Hamiltonian equations are sometimes invoked to model special problems; see [15] for examples.

Besides mechanical systems, the dual formulation can be insightful and sometimes even necessary for describing systems from other engineering domains. For instance, some networks and systems, such as the tunnel diode circuit discussed in “History of the Mixed-Potential Function,” cannot be described in a classical Lagrangian or Hamiltonian framework since the tunnel diode characteristic is not one-to-one and thus cannot be expressed in terms of a content function.

Additional examples that cannot be described in terms of a Lagrangian, but do admit a co-Lagrangian formulation, include electrical networks with varactors, which are nonlinear voltage-controlled capacitive elements that cannot be described in terms of the charge, and the Josephson junction circuit model, which contains a flux-controlled inductive element for which the Legendre transform does not exist.

An additional assumption that is introduced to further simplify the setup of the four frameworks is that the inductive co-energy does not depend on the generalized displacements. This assumption means that the displacements associated with the individual inductive elements can all be expressed in terms of a set of independent generalized displacement coordinates, that is,  $q_\ell = \Phi q$ , with  $\Phi$  a constant matrix of appropriate dimensions. The corresponding flows  $f_\ell = \dot{q}_\ell$  and  $f = \dot{q}$  are then related by  $f_\ell = \Phi f$ , which means that the total inductive co-energy can be expressed solely in terms of  $f$ . Although  $\Phi$  is typically constant for electrical networks and translational mechanical systems, the selection of a set of generalized configuration coordinates for rotating mechanical systems often gives rise to a displacement-dependent mapping of the form

$$q_\ell = \Phi(q), \quad (23)$$

changing, for example, Cartesian coordinates to polar, cylindrical, or spherical coordinates. Consequently, differentiation of (23) with respect to time yields the flow

$$f_\ell = \nabla_q \Phi(q) f =: \hat{\Phi}(q, f), \quad (24)$$

which yields a function of both  $q$  and  $f$ , and thus extends the inductive co-energy from  $T^*(f)$  to  $T^*(q, f)$ . Another instance where the inductive co-energy may become a function of both  $q$  and  $f$  is the case in which connections are made between different physical domains [4]. An example for which it is convenient to perform a change of coordinates is the inverted pendulum on a cart system.

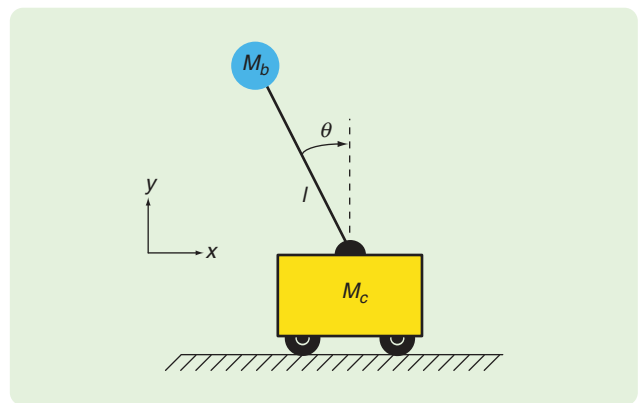

FIGURE 6 Inverted pendulum on a cart. The mass of the cart and the point mass (the bob) at the end of the rod are denoted by  $M_c$  and  $M_b$ , respectively. The rod with length  $l$  is considered massless.



## History of the Mixed-Potential Function

At a June 1958 conference in Brussels, Leo Esaki presented a new type of diode he had developed at Sony and for which he received a Ph.D. in physics and, later, the 1973 Nobel prize in physics. The characteristic curve of the Esaki or tunnel diode, named for the quantum-mechanical tunneling effect it exploited, contains a region in which the current decreases as the voltage increases. This region of negative resistance made it possible to construct bistable circuits, which were used as switching or memory elements (flip-flops) in early computers. To gain a better understanding and to guarantee safe operation of these circuits, Jürgen Moser developed a mathematical technique for analyzing their stability [S11]. His method was based on the study of a power related scalar function leading to quantitative restrictions on the circuit parameters so as to ensure stable switchings. We now briefly outline Moser's original idea and motivation.

### MOTIVATION FOR A NEW THEORY

Consider the tunnel diode circuit depicted in Figure S5, where  $I = I_L$  denotes the current through the inductor  $L$  and  $V = V_C$  denotes the voltage across the capacitor  $C$ . The differential equations describing the circuit are given by

$$L\dot{I} = E - RI - V, \quad C\dot{V} = I - \hat{i}_g(V), \quad (\text{S11})$$

where the function  $\hat{i}_g(V)$  characterizes the relation between the voltage  $V$  and the current  $I_g$  through the branch of the tunnel diode. In Figure S5 the characteristic curve is plotted, and the three equilibrium points of the circuit are shown. Two of the equilibria are asymptotically stable, whereas the equilibrium in the region of negative resistance is unstable. For the design of a flip-flop circuit it is useful to know when all trajectories tend to the asymptotically stable equilibrium points to exclude bounded trajectories, such as limit cycles, that never reach the equilibrium points. The most common way to proceed is to find a

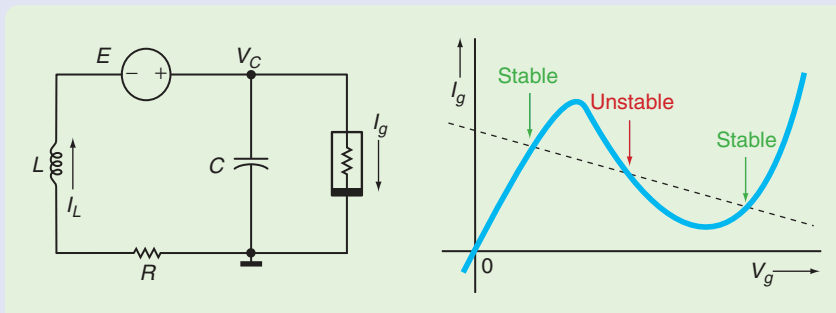

**FIGURE S5** Tunnel diode circuit. The tunnel diode has a nonlinear voltage-controlled constitutive relationship that contains a region of negative resistance. This characteristic made it possible to construct bistable circuits, which were used as switching or memory elements (flip-flops) in early computers. Note that the constitutive relationship of the tunnel diode is not invertible since it is not a single-valued function of the voltage. Consequently, the tunnel diode circuit cannot be described using the Lagrangian equations because the associated content is not globally defined.

Lyapunov function. As with many physical systems, a Lyapunov function candidate is the total stored energy in the circuit. However, this function is not useful for investigating stability for the tunnel diode circuit [S11].

### ALTERNATIVE LYAPUNOV ARGUMENT

To circumvent this problem, Moser's key idea was to introduce the scalar function

$$\mathcal{P}(I, V) = \frac{1}{2}RI^2 - EI - \int_0^V \hat{i}_g(V_g)dV_g + IV, \quad (\text{S12})$$

so that the differential equations (S11) can be rewritten as

$$\begin{aligned} -L\dot{I} &= \nabla_I \mathcal{P}(I, V), \\ C\dot{V} &= \nabla_V \mathcal{P}(I, V). \end{aligned}$$

(Here we use an opposite sign convention in comparison with [S11].) Observe that the values of (S12) have the units of power (current  $\times$  voltage) and that its extrema coincide with the equilibria of (S11). However, (S12) does not qualify as a Lyapunov function since its time derivative is indefinite. For that reason, Moser introduced the alternative function

$$\mathcal{O}(I, V) = \frac{L}{2}(E - RI - V)^2 + \frac{C}{2}(I - \hat{i}_g(V))^2, \quad (\text{S13})$$

whose time derivative implies that all trajectories tend to the set of stable equilibria if  $\hat{i}'_g(V) := d\hat{i}_g(V)/dV > 0$ , that is, the slope of the characteristic curve of the tunnel diode must be positive for all  $V$ . However, this function still does not take into account the region of negative resistance. Finally, the combination of the two functions  $S = \mathcal{O} + \lambda\mathcal{P}$ , with arbitrary constant  $\lambda$ , yields

$$\dot{S}(I, V) = -\frac{R + \lambda L}{L^2}(E - RI - V)^2 - \frac{\hat{i}'_g(V) - \lambda C}{C^2}(I - \hat{i}_g(V))^2.$$

The derivative  $\dot{S}(I, V)$  is negative definite if  $\lambda$  is chosen in the interval

$$-\frac{R}{L} < \lambda < \frac{\hat{i}'_g(V)}{C},$$

where it is assumed that  $\hat{i}'_g(V) > -CRL^{-1}$ . The condition  $\hat{i}'_g(V) > -CRL^{-1}$  puts a restriction on the steepness of the slope of the negative resistance region of the tunnel diode and guarantees that all trajectories converge to the set of stable equilibria.

### THE BRAYTON-MOSER EQUATIONS

Four years after [S11] appeared, Moser generalized the theory together with Brayton in [19] to the class of

topologically complete circuits. A circuit is topologically complete if each branch of the circuit can be expressed either in terms of the inductor currents  $I$ , or the capacitor voltages  $V$ , or both, and if it can be split up into two subcircuits, say  $\Sigma_a$  and  $\Sigma_b$ , where  $\Sigma_a$  contains the current-controlled inductors and current-controlled resistors, and  $\Sigma_b$  contains the voltage-controlled capacitors and voltage-controlled resistors and conductors. The  $\mathcal{P}$ -function for such a circuit then takes the form

$$\mathcal{P}(I, V) = \mathcal{D}(I) - \mathcal{D}^*(V) + V^\top N I, \quad (\text{S14})$$

where

$$\mathcal{D}(I) = \int_0^{N_r I} \hat{V}_r^\top(I_r) dI_r$$

represents the resistive content capturing the current-controlled resistors and sources contained in  $\Sigma_a$ , that is, the constitutive relations between the currents through the resistors  $I_r$  and the voltages across the resistors is given by  $V_r = \hat{V}_r(I_r)$ , and

$$\mathcal{D}^*(V) = \int_0^{N_g V} \hat{I}_g^\top(V_g) dV_g$$

represents the resistive co-content capturing the voltage-controlled resistors, conductors, and sources contained in  $\Sigma_b$ , that is, the constitutive relations between the voltages across the conductors  $V_g$  and the currents through the conductors is given by  $I_g = \hat{I}_g(V_g)$ . The term  $V^\top N I$  represents the instantaneous power delivered from  $\Sigma_a$  to  $\Sigma_b$ . Here, the matrices  $N_r$ ,  $N_g$ , and  $N$ , with entries  $\pm 1, 0$ , stem from applying Kirchhoff's voltage and current laws to the circuit. Thus, the circuit is completely determined by a mix of three different potential functions; hence Brayton and Moser call (S14) the *mixed-potential* function. In compact notation, the dynamics of a possibly nonlinear RLC circuit can be described as

$$Q(z)\dot{z} = \nabla_z \mathcal{P}(z), \quad (\text{S15})$$

with  $z = \text{col}(I, V)$  and

$$Q(z) = \begin{bmatrix} -L(I) & 0 \\ 0 & C(V) \end{bmatrix}, \quad (\text{S16})$$

where  $L(I)$  and  $C(V)$  are the incremental inductance and capacitance matrices. This system of differential equations is commonly known as the *Brayton-Moser (BM) equations*.

Although the BM equations (S15), together with (S16) and the mixed-potential of the form (S14), are due to Brayton and Moser [19], it is noteworthy to mention that similar ideas were already developed earlier by Wells [S12] and Stöhr [S13]. In particular, the similarity of the mixed-potential with Wells's power function is remarkable. In addition to including dissipative forces to describe the behavior of resistors, Wells used the power function to include conservative forces to describe the behavior of capacitors and externally applied forces to describe

external voltage sources. The terms in Wells's power function associated with the conservative forces coincide with the instantaneous power transfer term of the mixed-potential function, where  $N$  is the identity matrix.

## A FAMILY OF BRAYTON-MOSER DESCRIPTIONS

Motivated by the tunnel diode example, the principal application of the mixed-potential function concerns its use in determining stability criteria for possibly nonlinear networks admitting a description of the form (S15), together with (S14) and (S16). Indeed, it is now easily seen that  $\dot{\mathcal{P}}(z)$  is a quadratic form in  $\dot{z}$ , that is,

$$\dot{\mathcal{P}}(z) = \dot{z}^\top Q(z)\dot{z}. \quad (\text{S17})$$

Hence for circuits without capacitors (RL circuits), we have  $z = I$ ,  $Q(I) = -L(I)$ , and  $\mathcal{P}(I) = \mathcal{D}(I)$ . Under the condition that  $L(I)$  is positive definite, as is usually the case, we obtain  $\dot{\mathcal{P}}(I) \leq 0$ , which, by the invariant set theorem, implies that each bounded  $I$  approaches the set of equilibria, as  $t \rightarrow \infty$ . A similar result pertains to circuits without inductors, that is, RC circuits.

However, for RLC circuits the symmetric part of  $Q(z)$  is indefinite. Brayton and Moser's key observation is to generate a new pair  $\{\tilde{Q}, \tilde{\mathcal{P}}\}$  such that the symmetric part of  $\tilde{Q}$  is at least negative semidefinite. The construction is as follows. For each constant symmetric matrix  $M$  and real number  $\lambda$ , a new mixed-potential is obtained from

$$\tilde{\mathcal{P}}(z) = \lambda \mathcal{P}(z) + \frac{1}{2} \nabla_z^\top \mathcal{P}(z) M \nabla_z \mathcal{P}(z), \quad (\text{S18})$$

yielding  $\dot{\tilde{\mathcal{P}}}(z) = \dot{z}^\top \tilde{Q}(z)\dot{z}$ , with

$$\tilde{Q}(z) = \lambda Q(z) + \nabla_z^2 \mathcal{P}(z) M Q(z). \quad (\text{S19})$$

The original ideas of [S11] are then generalized into several theorems [19], each imposing particular restrictions on the circuit parameters or the topology. The first three theorems presented in [19] are summarized below.

### Theorem S1

If  $R := \nabla_I^2 \mathcal{D}(I)$  is constant and nonsingular,  $\mathcal{D}^*(V) \rightarrow \infty$  as  $|V| \rightarrow \infty$ , and

$$\|L^{1/2}(I)R^{-1}N^\top C^{-1/2}(V)\| < 1,$$

then each trajectory of (106) tends to the set of equilibria as  $t \rightarrow \infty$ .

The proof of the theorem follows by selecting  $\lambda = -1$  and  $M = \text{diag}(2R^{-1}, 0)$  in (S18) and (S19), and by invoking the invariant set theorem. Note that for topologically complete circuits the theorem requires the resistors in  $\Sigma_a$  to be linear and to have sufficient damping in each current coordinate. The latter condition is satisfied if each inductor has some series resistance, no matter how small. Also note that the conditions of the theorem are independent of the resistors in  $\Sigma_b$ . The following result is the complementary or dual version of Theorem S1.

**TABLE S1 Assumptions for Brayton and Moser's stability theorems.**

Type of Element	Theorem S1	Theorem S2	Theorem S3
Resistive	Linear	Nonlinear	Nonlinear
Conductive	Nonlinear	Linear	Nonlinear
Inductive and capacitive	Nonlinear	Nonlinear	Linear

### Theorem S2

If  $G := \nabla_V^2 D^*(V)$  is constant and nonsingular,  $\mathcal{D}(I) \rightarrow \infty$  as  $|I| \rightarrow \infty$ , and

$$\|C^{1/2}(V)G^{-1}NL^{-1/2}(I)\| < 1,$$

then each trajectory of (S15) tends to the set of equilibria as  $t \rightarrow \infty$ .

The proof of Theorem S2 is similar to the proof of Theorem S1, except that  $\lambda = 1$  and  $M = \text{diag}(0, 2G^{-1})$ , which means that every capacitor must possess some parallel conductance. The third theorem does not require the resistors to be linear, but assumes linear inductors and capacitors.

### Theorem S3

If  $L$  and  $C$  are constant, symmetric, and positive definite, and

$$\mu_1\{L^{-1/2}R(I)L^{-1/2}\} + \mu_2\{C^{-1/2}G(V)C^{-1/2}\} > 0,$$

where  $\mu\{\cdot\}$  represents the infimum of the eigenvalues of the respective matrices, then each bounded trajectory of (S15) tends to the set of equilibria as  $t \rightarrow \infty$ .

Theorem S3 follows by selecting  $\lambda = (1/2)(\mu_2 - \mu_1)$  and  $M = \text{diag}(L, C)^{-1}$ . The requirement that  $M$  in (S18) and (S19) must be chosen to be constant is precisely the reason for the different linearity assumptions on the admissible circuit elements. In summary, Table S1 shows the assumptions on the circuit elements regarding the applicability of each of the three theorems.

It is important to realize that the requirements of theorems S1, S2, and S3 are only sufficient conditions that establish comparisons between different time constants or frequencies. Indeed, the application of Theorem S1 to the tunnel diode circuit yields the condition  $R > \sqrt{L/C}$ , which can be rewritten as

$$RC > \frac{L}{R},$$

where both sides of the inequality have the units of seconds. A similar discussion holds for the stability condition  $\tilde{\gamma}_g(V) > -CRL^{-1}$  discussed above. Note that the same condition follows from the application of Theorem S3. Theorem S2 cannot be applied since it requires linearity of the resistors in  $\Sigma_b$ , which in this case is the tunnel diode.

### STATE OF THE ART

During the last four decades several notable extensions and generalizations of the BM theory have been presented in the

literature. Most of these extensions are based on the topological structure of the circuit. In [S14]–[S16], and [3], a topological mixed-potential is derived from a variational point of view. These observations are proved more rigorously in [S17]. The inclusion of ideal transformers is treated in [S18]. In [S19], the concept of pseudocontent and pseudocontent is introduced to carry over the ideas of BM to topologically noncomplete circuits. The problem of finding the largest class of circuits for which a mixed-potential function can be constructed is discussed in [S20] and [28]. Furthermore, based on the ideas presented in [S19], the extension of Theorem S1 and S2 to circuits having noninvertible  $R$  or  $G$  matrices, as well as the applicability of the stability theory to noncomplete circuits, is presented in [26]. A generalization of Brayton and Moser's stability theorems that also includes the analysis of circuits that contain nonlinear resistors, conductors, inductors, and capacitors simultaneously is given in [S21]. Geometrical aspects of the concept of the mixed-potential function can be found in [S20], [S22]–[S26], and [11].

### REFERENCES

- [S11] J. K. Moser, "Bistable systems of differential equations with applications to tunnel diode circuits," *IBM J. Res. Develop.*, vol. 5, pp. 226–240, 1960.
- [S12] D. A. Wells, "A power function for the determination of Lagrangian generalized forces," *J. Appl. Phys.*, vol. 16, pp. 535–538, 1945.
- [S13] A. Stöhr, "Über gewisse nicht notwendig lineare  $(n+1)$ -pole," *Arch. Electron. Übertr. Tech.*, vol. 7, pp. 546–548, 1953.
- [S14] J. O. Flower, "The topology of the mixed-potential function," *Proc. IEEE*, vol. 56, pp. 1721–1722, Oct. 1968.
- [S15] J. O. Flower, "The existence of the mixed-potential function," *Proc. IEEE*, vol. 56, pp. 1735–1736, Oct. 1968.
- [S16] D. L. Jones and F. J. Evans, "Variational analysis of electrical networks," *J. Franklin Inst.*, vol. 295, no. 1, pp. 9–23, 1973.
- [S17] F. M. Massimo, H. G. Kwatny, and L. Y. Bahar, "Derivation of the Brayton-Moser equations from a topological mixed-potential function," *J. Franklin Inst.*, vol. 310, no. 415, pp. 259–269, Oct./Nov. 1980.
- [S18] E. H. Horneber, "Application of the mixed-potential function for formulating normal form equations for nonlinear RLC networks," *Int. J. Circuit Theory Appl.*, vol. 6, pp. 345–362, 1978.
- [S19] L. O. Chua, "Stationary principles and potential functions for nonlinear networks," *J. Franklin Inst.*, vol. 296, no. 2, pp. 91–114, Aug. 1973.
- [S20] W. Marten, L. O. Chua, and W. Mathis, "On the geometrical meaning of pseudo hybrid content and mixed-potential," *Arch. Electron. Übertr.*, vol. 46, no. 4, pp. 305–309, 1992.
- [S21] D. Jeltsema and J. M. A. Scherpen, "On Brayton and Moser's missing stability theorem," *IEEE Trans. Circuits Syst. II*, vol. 52, no. 9, pp. 550–552, 2005.
- [S22] R. K. Brayton, "Nonlinear reciprocal networks," in *Mathematical Aspects of Electrical Network Analysis*. Providence: American Mathematical Society, 1971, pp. 1–15.
- [S23] S. Smale, "On the mathematical foundations of electrical circuit theory," *J. Differ. Equ.*, vol. 7, no. 1–2, pp. 193–210, 1972.
- [S24] W. Mathis, *Theorie Nichtlinearer Netzwerke*. Berlin: Springer-Verlag, 1987.
- [S25] G. Blankenstein, "Geometric modeling of nonlinear RLC circuits," *IEEE Trans. Circuits Syst. I*, vol. 52, no. 2, pp. 396–404, 2005.
- [S26] D. Jeltsema. (2005) Modeling and control of nonlinear networks: A power-based perspective, Ph.D. Thesis, Delft Univ. Technol. [Online]. Available: <http://repository.tudelft.nl/file/82874/363811>

### Example 3: Inverted Pendulum on a Cart

Consider the inverted pendulum mounted on a cart in Figure 6. We assume that the rod with length  $l$  is massless, and denote the cart mass by  $M_c$  and the point mass (the bob) at the upper end of the inverted pendulum by  $M_b$ . Since the system moves in the  $x$ - $y$  plane, its configuration can be described in terms of Cartesian coordinates, namely, the displacement of the cart in the horizontal direction  $(x, 0)$  and the displacement of the bob  $(x_b, y_b)$ . The kinetic co-energy in this case is given by

$$T^*(\dot{x}, \dot{x}_b, \dot{y}_b) = \frac{M_c}{2} \dot{x}^2 + \frac{M_b}{2} (\dot{x}_b^2 + \dot{y}_b^2).$$

However, since the pendulum has only one degree of freedom, a more convenient choice of configuration coordinates for the bob is its angular displacement  $\theta$  with respect to the vertical axis. Denoting  $q = \text{col}(x, \theta)$  and  $q_\ell = \text{col}(x, x_b, y_b)$ , we proceed by applying a coordinate transformation of the form (23), with

$$\Phi(q) = \begin{bmatrix} x \\ x + l \sin(\theta) \\ l \cos(\theta) \end{bmatrix}.$$

Hence the velocities are given by  $f_\ell = \text{col}(\dot{x}, \dot{x}_b, \dot{y}_b)$ , where

$$\begin{bmatrix} \dot{x} \\ \dot{x}_b \\ \dot{y}_b \end{bmatrix} = \begin{bmatrix} 1 & 0 \\ 1 & l \cos(\theta) \\ 0 & -l \sin(\theta) \end{bmatrix} \begin{bmatrix} \dot{x} \\ \dot{\theta} \end{bmatrix} =: \hat{\Phi}(q, f),$$

so that the kinetic co-energy can be expressed as

$$T^*(q, f) = \frac{M_c + M_b}{2} \dot{x}^2 + M_b l \dot{x} \dot{\theta} \cos(\theta) + \frac{M_b l^2}{2} \dot{\theta}^2, \quad (25)$$

which now depends on both generalized displacement and velocity coordinates. ■

### THE BRAYTON-MOSER EQUATIONS

Having in mind the modified Lagrangian equations (17) and (18), consider a system that consists of  $n_\ell$  inductive and  $n_r$  resistive elements, either flow controlled or one to one, and denote this system as  $\Sigma_a$ . The underlying configuration variables are the generalized displacements associated with the inductive elements, that is,  $q = \text{col}(q_1, \dots, q_{n_\ell})$ . Furthermore, assume that the system has  $n_e$  external ports (or  $n_e + 1$  external terminals) associated with a set of efforts  $e_a$  and flows  $f_a$  (see Figure 7). The external flows are related to the inductive flows  $f = \dot{q}$  through the relationship  $f_a = N_a f$ , where  $N_a$  is an  $n_e \times n_\ell$  matrix. If the resistive elements admit a resistive content function  $\mathcal{D}(f)$ , then the Lagrangian equations (17) take the form

$$\frac{d}{dt} \nabla_f \mathcal{L}(f) = -\nabla_e \left( \mathcal{D}(f) - \int_0^{N_a f} e_a^\top df_a \right), \quad (26)$$

where the Lagrangian is reduced to the total stored inductive co-energy, that is,  $\mathcal{L}(f) = T^*(f)$ , and the right-hand term inside parentheses represents the *total content* associated with the system  $\Sigma_a$ .

On the other hand, consider a system  $\Sigma_b$  that consists of  $n_c$  capacitive and  $n_g$  resistive elements, either effort-controlled or one-to-one, having the same number of external ports or terminals as  $\Sigma_a$  and as underlying configuration variables the generalized momenta associated with the capacitive elements, that is,  $p = \text{col}(p_1, \dots, p_{n_c})$ . If the efforts and flows associated with these external ports are denoted as  $e_b$  and  $f_b$ , respectively, and  $e_b = N_b e$ , where  $e = \dot{p}$  and  $N_b$  an  $n_e \times n_c$  matrix, then the co-Lagrangian equations (18) take the form

$$\frac{d}{dt} \nabla_e \mathcal{L}^*(e) = -\nabla_e \left( \mathcal{D}^*(e) - \int_0^{N_b e} f_b^\top de_b \right). \quad (27)$$

In this case, the co-Lagrangian is reduced to the total stored capacitive co-energy, that is,  $\mathcal{L}^*(e) = \mathcal{V}^*(e)$ , and the right-hand term inside parentheses represents the *total co-content* associated with the system  $\Sigma_b$ .

Suppose now that the two systems of Figure 7 are interconnected through  $e_a = -e_b$  and  $f_b = f_a$ , which in this case is tantamount to connecting the respective terminals. Subtracting the total content and co-content functions produces the scalar function

$$\mathcal{P}(f, e) = \mathcal{D}(f) - \mathcal{D}^*(e) + e^\top N f, \quad (28)$$

where we use the fact that the sum of the two integrals appearing at the right-hand sides of (26) and (27) reduce, by means of integration by parts, to  $e^\top N f$ , with  $N := N_b^\top N_a$ . Consequently, (26) and (27) combine into one set of equations given by

$$-\frac{d}{dt} \nabla_f \mathcal{H}^*(f, e) = \nabla_f \mathcal{P}(f, e), \quad (29)$$

$$\frac{d}{dt} \nabla_e \mathcal{H}^*(f, e) = \nabla_e \mathcal{P}(f, e), \quad (30)$$

where  $\mathcal{H}^*(f, e) = T^*(f) + \mathcal{V}^*(e)$  represents the total co-energy. Equations (29) and (30), together with (28), are the BM equations, originally derived for nonlinear electrical circuits in [19]

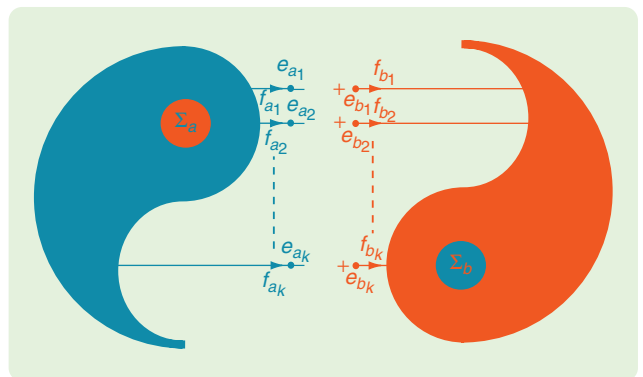

**FIGURE 7** Brayton-Moser system. The subsystem  $\Sigma_a$  contains the flow-controlled inductive and resistive elements, whereas  $\Sigma_b$  contains the effort-controlled capacitive and resistive elements. Since inductive and capacitive elements, as well as flow-controlled and effort-controlled resistors, are complementary or dual elements (see “Analogues, Duals, and Dualogues”), the subsystems  $\Sigma_a$  and  $\Sigma_b$  can also be considered as complementary or dual subsystems.

and [20]. The scalar function (28) is termed the *mixed-potential function*. The principle application of the mixed-potential is to derive Lyapunov-type stability theorems; see “History of the Mixed-Potential Function” for a historical overview. Although the original construction of the mixed-potential function starts from a differential version of Tellegen’s theorem, the above derivation starts from the classical energy-based framework. A similar exposition in the context of nonlinear electrical circuits can be found in [25]. From a system-theoretic perspective, the BM equations can be interpreted as a gradient system with respect to the mixed-potential function (28) and the indefinite metric defined by the symmetric matrix

$$Q(f, e) = \begin{bmatrix} -\nabla_f^2 \mathcal{H}^*(f, e) & 0 \\ 0 & \nabla_e^2 \mathcal{H}^*(f, e) \end{bmatrix}. \quad (31)$$

Note that the mixed-potential consists of three different potential functions (hence the adjective “mixed”), all of which have values with units of power. Moreover, the term  $e^\top N f$  equals the instantaneous power delivered from  $\Sigma_a$  to  $\Sigma_b$ , where  $N$  can be considered as the “turns ratio” matrix of a bank of ideal transformers. A proof of this fact can be found in [26]. Evidently, if  $-N$  equals the identity matrix and the system does not contain any resistive elements, then the mixed-potential reduces to  $\mathcal{P}(f, e) = -e^\top f$ . Hence the form of the resulting BM equations coincides with the co-Hamiltonian equations (14), which suggests that (29) and (30) can be considered as a generalized co-Hamiltonian description.

For ease of notation, the BM equations (29) and (30) can be compactly written as

$$Q(z)\dot{z} = \nabla_z \mathcal{P}(z), \quad (32)$$

where  $z = \text{col}(f, e)$  and  $Q(z)$  is given by (31).

We proceed by exemplifying the BM equations using the mechanical mass-spring system in Figure 3, followed by the

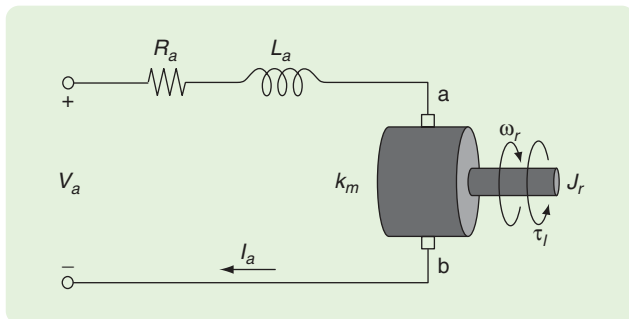

**FIGURE 8** A dc motor. The electrical energy supplied to the system by the armature voltage  $V_a$  is converted into rotational energy driving a load with torque  $\tau_l$ . The conversion of electric energy into mechanical energy is represented by a gyrator whose gyration ratio given by the motor constant  $k_m$ . The flow variables are represented by the current  $I_a$  through the armature inductor  $L_a$  and the angular velocity  $\omega_r$  of the rotor with inertia  $J_r$ . Since the armature resistor  $R_a$  is connected in series with the inductor it is considered as a current-controlled resistive element.

elementary dc motor, a nonlinear fluid system, and a heat exchanger. An example of a nonlinear electrical circuit is presented in “History of the Mixed-Potential Function.” More involved examples are discussed in the section “Rotating Mechanical Systems and Beyond.”

### Examples 1 and 2 Revisited: The Brayton-Moser Equations

As a first example to illustrate the BM equations, let us once more consider the mass-spring system depicted in Figure 3. Following the line of thought presented in the previous section, suppose that the mass and the spring are represented by the subsystems  $\Sigma_a = \{M\}$  and  $\Sigma_b = \{C\}$ , respectively. The next step is to define the system configuration. For system  $\Sigma_a$  we select  $x = x_M$  and for system  $\Sigma_b$  we select  $p = p_K$ , so that, as above, the flow equals  $v = v_M$  and the effort equals  $F = F_K$ . The mixed-potential function is determined from the interconnection of the two subsystems  $\Sigma_a$  and  $\Sigma_b$ . Since  $F_M = -F$  and  $v_K = v$ , we obtain

$$\mathcal{P}(v, F) = Fv, \quad (33)$$

while the form of the co-Hamiltonian is given in (15). Hence, substituting (33) into (29) and (30) yields the equations of motion

$$-M\dot{v} = F, \quad C\dot{F} = v. \quad (34)$$

Additionally, if the mass is subject to linear viscous friction or if a damper is placed between the wall and the mass, such as in Figure 3 or Figure 5(a), we have  $\Sigma_a = \{M, R\}$  and  $\Sigma_b = \{C\}$ , respectively. Hence, the mixed-potential can be modified with the addition of the resistive content function

$$\mathcal{P}(v, F) = \frac{R}{2}v^2 + Fv.$$

If we also insert a damper between the mass and the spring, as in Figure 5(c), we have  $\Sigma_a = \{M, R_1\}$  and  $\Sigma_b = \{C, R_2\}$ , and thus

$$\mathcal{P}(v, F) = \frac{R_1}{2}v^2 - \frac{F^2}{2R_2} + Fv.$$

Note that the difference in sign between (34) and the co-Hamiltonian equations (16) is due to the chosen reference directions in the selection of the system configuration variables. ■

### Example 4: DC Motor [21]

In its simplest practical form the dc motor shown in Figure 8 consists of an armature inductance  $L_a$ , an armature resistance  $R_a$ , and a rotor inertia  $J_r$ . The input of the system is the armature voltage  $V_a$ , and the load torque is denoted by  $\tau_l$ . The total stored co-energy is given by  $\mathcal{H}^*(I_a, \omega_r) = (1/2)L_a I_a^2 + (1/2)J_r \omega_r^2$ , where the flows  $I_a$  and  $\omega_r$  denote the armature current and the angular velocity of the rotor, respectively. Furthermore, the armature inductance and the rotor inertia both belong to the class of inductive elements. However, due to the

gyrative nature of the system we cannot find a mixed-potential function for this setting. To circumvent this problem, we use the fact that the inertia “seen” from the electrical terminals  $a$  and  $b$  behaves like a capacitive element with capacitance  $C_r := k_m^{-2} J_r$  and associated effort  $e_r := k_m \omega_r$ , whereas the load torque translates into the flow source  $f_l := k_m^{-1} \tau_l$ . Consequently, we can split the system into a subsystem  $\Sigma_a = \{L_a, R_a, V_a\}$  and a subsystem  $\Sigma_b = \{C_r, f_l\}$ . Setting  $f_a = I_a$ , the corresponding content, co-content, and co-energy in terms of flows and efforts are given by

$$\mathcal{D}(f_a) = \frac{R_a}{2} f_a^2 - V_a f_a, \quad \mathcal{D}^*(e_r) = e_r f_l,$$

and

$$\mathcal{H}^*(f_a, e_r) = \frac{L_a}{2} f_a^2 + \frac{C_r}{2} e_r^2,$$

respectively. The coupling between the two subsystems  $\Sigma_a$  and  $\Sigma_b$  is represented by a unit transformer with  $N = 1$ , so that the mixed-potential takes the form

$$\mathcal{P}(f_a, e_r) = \frac{R_a}{2} f_a^2 - V_a f_a - e_r f_l + e_r f_a.$$

Substituting  $\mathcal{P}(f_a, e_r)$  into (29) and (30) yields the equations of motion

$$\begin{aligned} -L_a \dot{f}_a &= e_r + R_a f_a - V_a, \\ C_r \dot{e}_r &= f_a - f_l, \end{aligned}$$

or, equivalently, in terms of the electrical and mechanical variables,

$$\begin{aligned} -L_a \dot{I}_a &= k_m \omega_r + R_a I_a - V_a, \\ J_r \dot{\omega}_r &= k_m I_a - \tau_l. \end{aligned}$$

### Example 5: A Fluid System

Consider the fluid system shown in Figure 9, which consists of two open tanks with capacities  $C_1$  and  $C_2$ , respectively. The first tank, with pressure drop (effort)  $P_{C_1}$ , is fed by a volume flow source  $Q_{in}$  and linked to the second tank, with pressure drop (effort)  $P_{C_2}$ , by a long pipe with fluid inertia  $L_p$ , resistance  $R_p$ , and flow rate  $Q_{L_p}$  (flow). The second tank discharges at atmospheric pressure through an orifice dissipator  $R_o$  that can be described by the nonlinear constitutive relationship  $P_{R_o} = G^{-1} Q_{R_o}^2$ , where  $P_{R_o}$  and  $Q_{R_o}$  denote the pressure drop across and the flow rate through the orifice. Hence, the content function is  $\mathcal{D}(Q_{L_p}) = (1/2) R_p Q_{L_p}^2$ , the co-content function is

$$\mathcal{D}^*(P_{C_1}, P_{C_2}) = \int_0^{P_{C_2}} \sqrt{G P_{R_o}} dP_{R_o} - Q_{in} P_{C_1},$$

and the interconnection matrix is given by  $N = [-1 \ 1]^T$ . Hence, the mixed-potential for the system has the form

$$\begin{aligned} \mathcal{P}(Q_{L_p}, P_{C_1}, P_{C_2}) &= \frac{R_p}{2} Q_{L_p}^2 - \int_0^{P_{C_2}} \sqrt{G P_{R_o}} dP_{R_o} + Q_{in} P_{C_1} \\ &\quad + Q_{L_p} (P_{C_2} - P_{C_1}). \end{aligned}$$

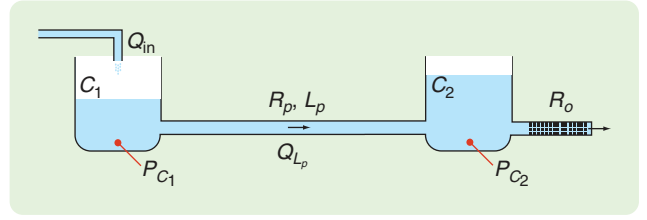

**FIGURE 9** Fluid system. The two tanks are considered as the capacitive elements with capacities  $C_1$  and  $C_2$ . The pipe that connects the two tanks is modeled as an inductive element  $L_p$  and a resistance  $R_p$ . Furthermore, the fluid that is fed to the system and the orifice dissipator  $R_o$  at the outlet are both modeled as nonlinear effort-controlled resistive elements. The state variables are the pressure drops associated with the two tanks and the flow rate through the pipe.

Furthermore, the co-Hamiltonian is given by the total stored fluid co-energy

$$\mathcal{H}^*(Q_{L_p}, P_{C_1}, P_{C_2}) = \frac{C_1}{2} P_{C_1}^2 + \frac{C_2}{2} P_{C_2}^2 + \frac{L_p}{2} Q_{L_p}^2.$$

Substituting  $\mathcal{P}(Q_{L_p}, P_{C_1}, P_{C_2})$  and  $\mathcal{H}^*(Q_{L_p}, P_{C_1}, P_{C_2})$  into (29) and (30) yields the equations of motion

$$\begin{aligned} -L_p \dot{Q}_{L_p} &= R_p Q_{L_p} + P_{C_2} - P_{C_1}, \\ C_1 \dot{P}_{C_1} &= Q_{in} - Q_{L_p}, \\ C_2 \dot{P}_{C_2} &= Q_{L_p} - \sqrt{G P_{C_2}}. \end{aligned}$$

Note that  $\Sigma_a = \{L_p, R_p\}$  and  $\Sigma_b = \{C_1, C_2, R_o, Q_{in}\}$ . ■

### Example 6: A Heat Exchanger Cell [27]

Figure 10 shows a heat exchanger in which energy is exchanged between a cold stream, with inlet and outlet temperatures  $T_{c_i}$  and  $T_{c_o}$ , and a hot stream, with inlet and outlet temperatures  $T_{h_i}$  and  $T_{h_o}$ , respectively. The associated thermal capacities are denoted by  $C_c$  and  $C_h$ , whereas the heat transfer is modeled by

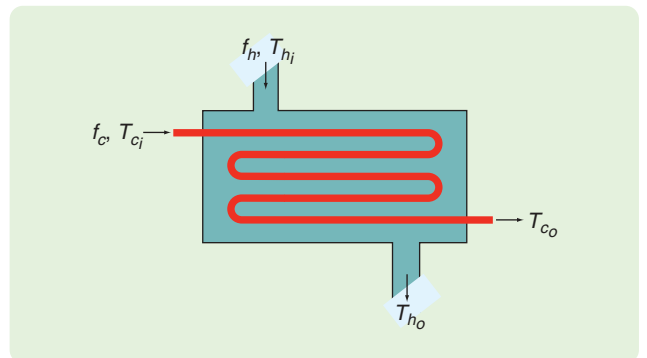

**FIGURE 10** A heat exchanger system in which energy is exchanged between a hot stream and a cold stream. The system has two efforts as state variables, namely, the temperature  $T_{c_o}$  of the cold stream and the temperature  $T_{h_o}$  of the hot stream. The associated thermal capacities are  $C_o$  and  $C_h$ , respectively, whereas the heat transfer is modeled by a thermal conductance  $G_{hc}$ . The inlet temperatures  $T_{c_i}$  and  $T_{h_i}$  are assumed to be constant. The control variables are the volumetric flow rates  $f_c$  and  $f_h$ .

a thermal conductance  $G_{hc}$ . The system can be described by the effort variables  $T_{c_0}$  and  $T_{h_0}$ . Under the assumption that the inlet temperatures are constant and the volumetric flow rates  $f_c$  and  $f_h$  are the control inputs, the total co-content is found as

$$\mathcal{D}^*(T_{c_0}, T_{h_0}) = \frac{G_{hc}}{2}(T_{c_0} - T_{h_0})^2 - \frac{\gamma_c}{2}(T_{c_0} - T_{c_i})^2 f_c - \frac{\gamma_h}{2}(T_{h_0} - T_{h_i})^2 f_h,$$

where the constants  $\gamma_c$  and  $\gamma_h$  depend on the density and specific heat of the respective streams. Since there are no inductive elements,  $\mathcal{D} = 0$  and  $N = 0$ . Then the mixed-potential consists only of the co-content, that is,  $\mathcal{P}(T_{c_0}, T_{h_0}) = -\mathcal{D}^*(T_{c_0}, T_{h_0})$ , which, together with the co-Hamiltonian  $\mathcal{H}^*(T_{c_0}, T_{h_0}) = (1/2)C_c T_{c_0}^2 + (1/2)C_h T_{h_0}^2$ , yields the nonlinear equations of motion

$$\begin{aligned} C_c \dot{T}_{c_0} &= -G_{hc}(T_{c_0} - T_{h_0}) + \gamma_c(T_{c_0} - T_{c_i})f_c, \\ C_h \dot{T}_{h_0} &= G_{hc}(T_{c_0} - T_{h_0}) + \gamma_h(T_{h_0} - T_{h_i})f_h. \end{aligned}$$

Note that  $\Sigma_a = \emptyset$  and  $\Sigma_b = \{C_c, C_h, G_{hc}, f_c, f_h\}$ . ■

### Topological Completeness

The main assumptions that lead to a mixed-potential function of the form (28) are i) that the system under consideration can be split into the two subsystems  $\Sigma_a$  and  $\Sigma_b$  and ii) that each element in  $\Sigma_a$  can be described by the flow variables associated with the inductive elements, and each element in  $\Sigma_b$  can be described by the effort variables

associated with the capacitive elements without violating the interconnection constraints applicable to the domain under consideration, such as Kirchhoff's laws or D'Alembert's principle. An electrical circuit that satisfies these topological properties is said to be *topologically complete*; for details, see "History of the Mixed-Potential Function." This terminology can naturally be administered to the multidomain case treated here.

If a system is not topologically complete, we can try to augment the system topology by adding inductive or capacitive elements, as described in [19] and [28], so that the augmented system becomes topologically complete. Indeed, consider the linear mechanical system of Figure 11(a). Obviously, the system is not topologically complete since the velocities and forces associated with the dampers  $R_1$  and  $R_2$  cannot directly be expressed in terms of the velocity  $v = v_M$  of the mass  $M$  and the force  $F = F_K$  of the spring with compliance  $C = K^{-1}$ . On the other hand, suppose that we add an additional mass  $M'$  as shown in Figure 11(b). Since  $v_{R_1} = v'$  and  $v_{R_2} = v' - v$ , with  $v' = v_{M'}$ , the augmented system is now topologically complete, and the associated mixed-potential function is given by

$$\mathcal{P}'(v, v', F) = \frac{R_1}{2}(v')^2 + \frac{R_2}{2}(v' - v)^2 - F_{in}v + F(v' - v) \quad (35)$$

and has the form (28). However, to find a mixed-potential for the original system we need to be able to eliminate the additional velocity  $v'$  from (35). Letting  $M' \rightarrow 0$  implies that  $\nabla_{v'} \mathcal{P}'(v, v', F) \equiv 0$ , or, equivalently,  $R_1 v' + R_2(v' - v) + F \equiv 0$ . Consequently, the original topologically noncomplete system is described implicitly by a set of differential algebraic equations (DAEs). Solving the latter constraint for  $v'$  yields

$$v' = \frac{1}{R}(R_2 v - F), \quad (36)$$

where  $R := R_1 + R_2$ . Substituting (36) into (35) then provides the mixed-potential function

$$\mathcal{P}(v, F) = \frac{R_1 R_2}{2R} v^2 - F_{in} v - \frac{F^2}{2R} - \frac{R_1}{R} F v. \quad (37)$$

Although (37) appears to be of the form (28), the content and co-content in (37) are not simply the sums of the content and co-content of the individual resistive elements in the system, respectively. Moreover,  $R_1$  and  $R_2$  act as a force divider that can be interpreted as a mechanical transformer with transformation ratio  $N = R_1/R$ . Therefore, the system cannot be decomposed into  $\Sigma_a$  and  $\Sigma_b$  since the interconnection structure depends on both  $R_1$  and  $R_2$ . Thus, even though the mixed-potential for a topologically noncomplete system cannot be interpreted as easily as in the topologically complete case, the concept per se remains applicable. In [28] algorithms are provided for constructing mixed-potential functions for a wide class of topologically noncomplete circuits. In addition, necessary conditions are

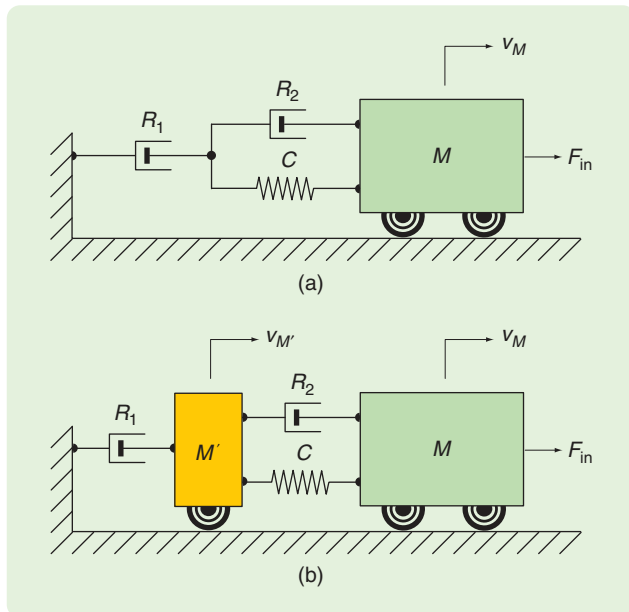

**FIGURE 11** Example of a mechanical topologically noncomplete system. The system shown in (a) is not topologically complete since the velocities and forces associated with the dampers  $R_1$  and  $R_2$  cannot directly be expressed in terms of the velocity of the mass  $M$  and the force of the spring  $C$ . As shown in (b), the system can be rendered topologically complete by adding a small mass  $M'$  to the common connection point of  $R_1$ ,  $R_2$ , and  $C$ . Then let  $M' \rightarrow 0$ .

given in [28] for the existence of the mixed-potential function. Mathematically speaking, the resulting DAE system belongs to the subset of index 1 systems.

The procedure illustrated above can in many cases be carried over to other domains. The original topologically non-complete system is then considered as a limiting case of the augmented system. Moreover, the addition of inductive and capacitive elements can often be justified on physical grounds since these elements are often present as parasitic elements. In the section “Rotating Mechanical Systems and Beyond” we provide necessary conditions for the existence of the mixed-potential function for a large class of systems.

## SWITCHED-MODE SYSTEMS

Switched-mode systems are systems for which the topology may change depending on certain discrete parameters. Examples include electrical power converters and mechanical systems with impacts. The switchings may be induced internally, as in the case of a diode in a power converter or an impact in a mechanical system, or it may be triggered externally as in the case of firing a thyristor in a power converter. Since the topology of a system is determined by the interconnection structure of the elements, it is not surprising that the BM description yields a mixed-potential function that depends on the position of the switches. To illustrate how the mixed-potential is altered by switching phenomena, we first extend the BM equations for systems containing a single independent switch.

The switch position, denoted by the scalar function  $\sigma$ , is assumed to take values in the discrete set  $\{0, 1\}$ . Furthermore, we assume that, for each switch position, the associated system admits the construction of a mixed potential. Adopting the terminology from [4], each mode can be characterized by a set of BM parameters as follows. When the switch position function takes the value  $\sigma = 1$ , the associated system, denoted by  $\Sigma^1$ , is characterized by a known set of BM parameters  $\Sigma^1 = \{Q^1, P^1\}$  satisfying

$$Q^1(z)\dot{z} = \nabla_z P^1(z). \quad (38)$$

Similarly, when the switch position function takes the value  $\sigma = 0$ , the associated system is characterized by  $\Sigma^0 = \{Q^0, P^0\}$  and satisfies

$$Q^0(z)\dot{z} = \nabla_z P^0(z). \quad (39)$$

Hence, a switched system arising from the systems  $\Sigma^1$  and  $\Sigma^0$  defines a *switched BM system* whenever it is completely characterized by the set of *switched BM parameters*  $\Sigma^\sigma = \{Q^\sigma, P^\sigma\}$  with switched mixed-potential

$$P^\sigma(z) = (1 - \sigma)P^0(z) + \sigma P^1(z), \quad (40)$$

satisfying

$$Q^\sigma(z)\dot{z} = \nabla_z P^\sigma(z). \quad (41)$$

The  $Q$ -matrices are usually not altered by the switch positions, in which case  $Q^\sigma(z) = Q(z)$ . Furthermore, the inclusion of

multiple switches is easily accomplished by appropriately extending (40) with  $\sigma_j \in \{0, 1\}$ , for  $j = 1, \dots, n_s$ , where  $n_s$  denotes the number of independent switches. Noncontrollable switches, such as diodes, can be treated as nonlinear resistors.

Switched BM equations are closely related to the averaged pulse-width modulation (PWM) models. See [4] for a discussion on this subject in the Lagrangian and Hamiltonian framework. A PWM switching function may be specified as

$$\sigma(t) = \begin{cases} 1 & \text{for } t_k \leq t < t_k + \delta(t_k)T, \\ 0 & \text{for } t_k + \delta(t_k)T \leq t < t_k + T, \end{cases}$$

for  $t_{k+1} = t_k + T, k = 0, 1, 2, \dots$ , where  $t_k$  represents a sampling instant,  $T$  is the fixed sampling period (duty cycle), and  $\delta(\cdot)$  is the duty ratio function of the switch whose values are in the closed interval  $[0, 1]$ . For (40) the averaging process means that  $z$  is replaced by the average state  $\bar{z}$ , representing the average efforts and flows, and the discrete control  $\sigma$  is replaced by its duty ratio function  $\delta$ . The consistency conditions on the averaged mixed-potential functions are thus given by

$$\begin{aligned} \mathcal{P}^\delta(\bar{z})|_{\delta=1} &= P^1(\bar{z}), \\ \mathcal{P}^\delta(\bar{z})|_{\delta=0} &= P^0(\bar{z}), \end{aligned}$$

where  $P^1(\bar{z})$  is the mixed-potential function for the extreme saturation value  $\delta = 1$ , and  $P^0(\bar{z})$  is the mixed-potential function for the extreme saturation value  $\delta = 0$ . Note that  $\mathcal{P}^\delta(\bar{z})$  can be considered as a weighted ratio, with weighting parameter  $\delta$ , between  $P^1(\bar{z})$  and  $P^0(\bar{z})$ .

### Example 7: A Power Converter

Consider the single switch dc-to-dc boost power converter depicted in Figure 12. Assume that the load resistor  $R_o$ ,

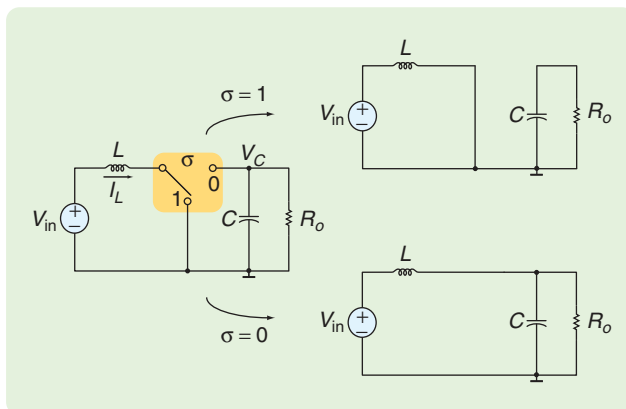

**FIGURE 12** A single switch boost converter topology. This power converter is used to realize an output dc voltage greater than its input dc voltage  $V_{in}$ . A boost converter is also called a step-up converter since it increases the input voltage. The boosting effect is accomplished by charging the inductor  $L$  with magnetic energy (switch in position  $\sigma = 1$ ). This magnetic energy is then released to charge the capacitor  $C$  (switch in position  $\sigma = 0$ ). Additionally, the capacitor operates as a filter element to smooth the switching effects in the current and voltage fed to the load  $R_o$ . In practice the switch is realized by a transistor and a diode.



capacitor  $C$ , and inductor  $L$  have linear constitutive relationships. The active switch  $\sigma$  is the external control input for the network. The converter has two stages, namely,  $\sigma = 1$  (switch ON) and  $\sigma = 0$  (switch OFF). Letting  $I = I_L$  denote the current (flow) through the inductor, and  $V = V_C$  the voltage (effort) across the capacitor, then the total stored co-energy equals  $\mathcal{H}^*(I, V) = (1/2)LI^2 + (1/2)CV^2$ . The mixed-potential for the switch in position  $\sigma = 0$  is given by

$$\mathcal{P}^0(I, V) = -V_{\text{in}}I - \frac{V^2}{2R_o} + VI,$$

yielding the differential equations

$$\begin{aligned} -L\dot{I} &= -V_{\text{in}} + V, \\ C\dot{V} &= I - \frac{V}{R_o}. \end{aligned}$$

Similarly, for the switch in position  $\sigma = 1$ , we have

$$\mathcal{P}^1(I, V) = -V_{\text{in}}I - \frac{V^2}{2R_o},$$

yielding the differential equations

$$\begin{aligned} -L\dot{I} &= -V_{\text{in}}, \\ C\dot{V} &= -\frac{V}{R_o}. \end{aligned}$$

Substituting  $\mathcal{P}^0(I, V)$  and  $\mathcal{P}^1(I, V)$  into (40), we obtain the switched mixed-potential function

$$\mathcal{P}^\sigma(I, V) = -V_{\text{in}}I - \frac{V^2}{2R_o} + (1 - \sigma)VI,$$

which, in turn, provides the switched equations of motion

$$\begin{aligned} -L\dot{I} &= -V_{\text{in}} + (1 - \sigma)V, \\ C\dot{V} &= (1 - \sigma)I - \frac{V}{R_o}. \end{aligned}$$

The conditions for the transition from ON to OFF, and vice versa, are determined externally by controlling the switch. ■

### Example 8: A Bouncing Pogo-Stick

Consider the vertically bouncing pogo stick depicted in Figure 13. The system consists of a mass  $M$  and a massless foot, interconnected by a linear spring with compliance  $C = K^{-1}$  and a damper  $R$ . The mass can move vertically under the influence of gravity  $g$ . The contact situation is described by  $\sigma = 0$  (foot has no ground contact, OFF) and  $\sigma = 1$  (foot has ground contact, ON). The co-energy storage in the mass and the spring equals  $\mathcal{H}^*(v, F) = (1/2)Mv^2 + (1/2)CF^2$ , where  $v = \dot{x}_M$  denotes the velocity of the mass and  $F = Kx_K$  denotes the force associated with the spring. Note that for  $\sigma = 0$  the mass is “disconnected” from the spring and damper, and the system equations can be described with help of the mixed-potential function

$$\mathcal{P}^0(v, F) = Mgv - \frac{F^2}{2R},$$

yielding the no-contact dynamics

$$\begin{aligned} -M\dot{v} &= Mg, \\ C\dot{F} &= -\frac{F}{R}. \end{aligned}$$

On the other hand, for  $\sigma = 1$ , we obtain

$$\mathcal{P}^1(v, F) = \frac{R}{2}v^2 + Mgv + Fv,$$

from which we deduce the contact dynamics

$$\begin{aligned} -M\dot{v} &= F + Rv + Mg, \\ C\dot{F} &= v. \end{aligned}$$

The contact and no-contact situations can be combined into a single switched mixed-potential

$$\begin{aligned} \mathcal{P}^\sigma(v, F) &= \sigma \frac{R}{2}v^2 \\ &\quad + Mgv - (1 - \sigma) \frac{F^2}{2R} + \sigma Fv, \end{aligned}$$

resulting in the switched BM system

$$\begin{aligned} -M\dot{v} &= \sigma(F + Rv) + Mg, \\ C\dot{F} &= \sigma v - (1 - \sigma) \frac{F}{R}. \end{aligned}$$

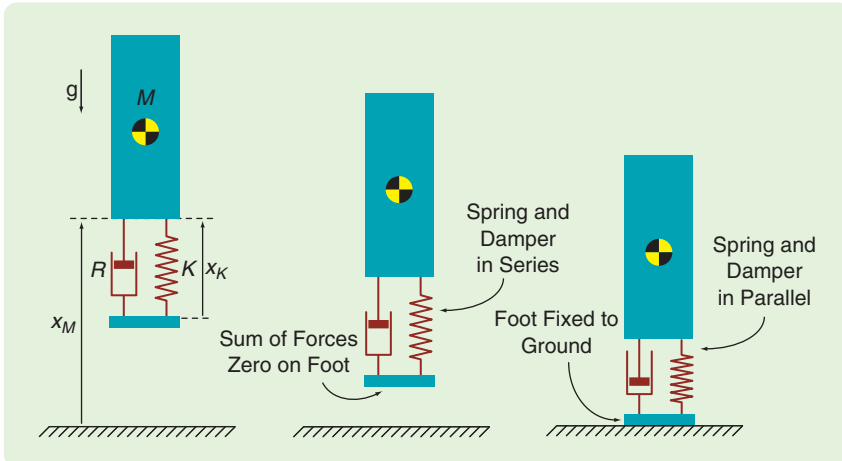

**FIGURE 13** The pogo stick as a switched-mode mechanical system. A pogo stick consists of a pole with a handle at one end, footpads on the other, and a spring that supports the stick and user when on the ground. Usually considered a children’s toy, it is used for hopping up and down by use of the spring. The device was patented in 1919 by George Hansburg, an Illinois toy designer. According to a legend, its origin can be traced back to a poor Burmese farmer who made one for his shoeless daughter, named Pogo, so she could hop daily to pray at the temple. Assuming the person that hops on the pogo stick can be modeled as a rigid body, the system can be modeled as a mass interconnected with a spring and a damper.

**The purpose of this article is to provide an overview  
of both the energy- and power-based modeling frameworks  
and to discuss their mutual relationships.**

Additionally, the conditions for switching between contact and no-contact are functions of the states. Contact is switched from OFF to ON when the velocity of the foot is either zero or negative in the contact situation, that is, when  $v - C\dot{F} \leq 0$ , and contact is switched from ON to OFF when  $v - C\dot{F} > 0$ . ■

### ROTATING MECHANICAL SYSTEMS AND BEYOND

As discussed above, for many mechanical systems, such as rotating systems found in robotics, it is often convenient to transform, for example, from Cartesian coordinates to polar coordinates as in (23). This transformation is illustrated by the inverted pendulum on a cart in Example 3. A consequence of the transformation is that the kinetic co-energy function becomes a function of both displacements and flows. Unfortunately, in this case the construction of a BM description becomes more complicated. Before we proceed, we first study the influence of a coordinate transformation as in (23) on the Lagrangian and Hamiltonian equations of motion.

Suppose that the total kinetic (inductive) co-energy of a mechanical system is given by

$$T^*(f_\ell) = \frac{1}{2} f_\ell^\top M f_\ell,$$

where  $M$  represents a constant mass or inertia (inductance) matrix and  $f_\ell$  denotes the corresponding velocities (flows) associated with the mass and inertia elements. Furthermore, suppose that the system has  $n$  degrees of freedom that can be described by a set of generalized coordinates  $q$  such that the relationship with the original (for example, Cartesian) coordinates  $q_\ell$  is given by (23). As in the case of the pendulum on a cart system, the kinetic co-energy can be rewritten in terms of the generalized coordinates and velocities as

$$T^*(q, f) = \frac{1}{2} f^\top \underbrace{\nabla_q^\top \Phi(q) M \nabla_q \Phi(q)}_{=: D(q)} f, \quad (42)$$

where  $D(q) \succ 0$  is the *generalized mass matrix*. Consequently, the Lagrangian becomes  $\mathcal{L}(q, f) = T^*(q, f) - \mathcal{V}(q)$ , so that (6) extends to the form

$$D(q)\dot{f} + B(q, f)f + \nabla_q \mathcal{V}(q) = 0, \quad (43)$$

which is commonly used in robotics. Here the term  $B(q, f)f$  reflects the *coriolis* and *centrifugal forces*, which stem from

the coordinate transformation and are workless. Furthermore, since the generalized momenta are now defined by  $p = \nabla_f \mathcal{L}(q, f) = D(q)f$ , the corresponding Hamiltonian takes the form

$$\mathcal{H}(q, p) = \frac{1}{2} p^\top D^{-1}(q)p + \mathcal{V}(q), \quad (44)$$

from which we obtain

$$\dot{q} = D^{-1}(q)p, \quad (45)$$

$$\dot{p} = -\frac{1}{2} \nabla_q (p^\top D^{-1}(q)p) - \nabla_q \mathcal{V}(q). \quad (46)$$

We refer to (45), (46) as a *standard mechanical system*.

Note that the existence of a co-Lagrangian and co-Hamiltonian (BM) description depends mainly on the ability to express  $q$  in terms of  $e_c$ . The presence of the coriolis and centrifugal forces obscures the construction of the BM equations significantly. In the next two sections we outline two methods that lead to a generalized form of the BM equations (32). In particular, the  $Q$ -matrix given by (31) loses its block-diagonal form. The mixed-potential functions essentially have the same form and interpretation as (28).

### Standard Mechanical Systems: Method I

Suppose that the Legendre transformation

$$\mathcal{V}^*(e_c) = e_c^\top q - \mathcal{V}(q), \quad (47)$$

where  $e_c = \nabla_q \mathcal{V}(q)$  exists at least locally in some interval. In such case,  $q = \hat{q}(e_c)$  and the generalized velocities  $f = \dot{q}$  can be expressed in terms of the conservative forces as

$$f = C(e_c)\dot{e}_c, \quad (48)$$

with incremental compliance matrix  $C(e_c) := \nabla_{e_c} \hat{q}(e_c)$ , so that (43) becomes

$$D(\hat{q}(e_c))\dot{f} + B(\hat{q}(e_c), f)C(e_c)\dot{e}_c + e_c = 0. \quad (49)$$

Now, introducing

$$P(f, e_c) = e_c^\top f \quad (50)$$

and

$$Q(f, e_c) = \begin{bmatrix} -D(\hat{q}(e_c)) & -B(\hat{q}(e_c), f)C(e_c) \\ 0 & C(e_c) \end{bmatrix} \quad (51)$$

we can rewrite (48) and (49) in a BM form (32). However, the  $Q$ -matrix (51) loses its interpretation as a pseudo-Riemannian metric since it is not symmetric. On the other hand, the mixed-potential (50) has the same interpretation as in (28) and determines the instantaneous rate of energy flowing from the kinetic part  $\Sigma_a$ , representing the masses, to the potential part  $\Sigma_b$ , representing the stiffnesses of the system.

The main obstacle, however, is the existence of the Legendre transformation (47), or in other words, the invertibility assumption of the conservative forces  $e_c = \hat{e}_c(q)$ . Moreover,  $C(e_c)$  must have full column rank to ensure that  $f_c = f$ . While the former condition is, at least locally, often satisfied for a large class of systems, the latter restricts the range of applications since the full rank condition requires that there are as many conservative forces as there are particles. Augmentation in a similar way as is done in the case of a topologically noncomplete system can overcome this problem; see the section "Topological Completeness."

Obviously, nonconservative forces can be included by extending (50) to

$$\mathcal{P}(f, e_c) = \mathcal{D}(f) + e_c^\top f. \quad (52)$$

In principle the mixed-potential function can include nonconservative velocities by means of a co-content function  $\mathcal{D}^*$ . An extensive treatment of Method I can be found in [29] and [30], where the concept of a pseudo-inductor is introduced as the electrical analogue of a nonconstant mass-inertia matrix.

### Standard Mechanical Systems: Method II

One approach to circumventing the drawbacks of Method I is to start from the Hamiltonian equations. First, we rewrite (45)–(46) in the form

$$\dot{z} = J \nabla_z \mathcal{H}(z), \quad (53)$$

with  $z = \text{col}(p, q)$ , and

$$J = \begin{bmatrix} 0 & -I_n \\ I_n & 0 \end{bmatrix}, \quad (54)$$

where  $I_n$  denotes the  $n \times n$  identity matrix. Note that the order of  $q$  and  $p$  are interchanged to be able to easily compare our forthcoming developments to the previous results.

For standard mechanical systems  $J^{-1} = J^\top$  exists. Hence, the Hamiltonian equations (53) can be rewritten as

$$J^{-1} \dot{z} = \nabla_z \mathcal{H}(z), \quad (55)$$

which directly gives rise to the suggestion of a BM type of system description (32). However, the matrix  $J^{-1}$  is skew symmetric and dimensionless, while the potential function  $\mathcal{H}(z)$  represents the total energy (44). On the other hand, borrowing inspiration from [19], the dynamics (55) can also be described by another pair, say  $\tilde{Q}$  and  $\tilde{\mathcal{P}}$ , that is,

$$\tilde{Q} \dot{z} = \nabla_z \tilde{\mathcal{P}}(z). \quad (56)$$

Indeed, for any constant and symmetric matrix  $S$  such pairs can be generated by

$$\begin{aligned} \tilde{\mathcal{P}}(z) &= \frac{1}{2} \nabla_z^\top \mathcal{H}(z) S \nabla_z \mathcal{H}(z), \\ \tilde{Q}(z) &= \nabla_z^2 \mathcal{H}(z) S J^{-1}. \end{aligned}$$

Having made these observations, our next task is to select a matrix  $S$  such that  $\tilde{\mathcal{P}}(z)$  in (56) takes a form similar to (28). Selecting

$$S = \begin{bmatrix} 0 & I_n \\ I_n & 0 \end{bmatrix},$$

we obtain

$$\begin{aligned} \tilde{\mathcal{P}}(z) &= \nabla_q^\top \mathcal{V}(q) D^{-1}(q) p \\ &\quad + \frac{1}{2} \nabla_q (p^\top D^{-1}(q) p) D^{-1}(q) p, \end{aligned} \quad (57)$$

together with

$$\tilde{Q}(z) = \begin{bmatrix} -D^{-1}(q) & \nabla_q (D^{-1}(q) p) \\ -\nabla_q^\top (p^\top D^{-1}(q)) & C^{-1}(q, p) \end{bmatrix}, \quad (58)$$

where we define the inverse compliance matrix

$$C^{-1}(q, p) := \nabla_q^2 \mathcal{V}(q) + \frac{1}{2} \nabla_q^2 (p^\top D^{-1}(q) p).$$

Observe that the skew-symmetric terms of (58) are directly associated with the coriolis and centrifugal forces. To show that the values of  $\tilde{\mathcal{P}}(z)$  have units of power, we use (45)–(46) to arrive at

$$\tilde{\mathcal{P}}(\cdot) = -\dot{p}^\top \dot{q} \quad (\text{force} \times \text{velocity}).$$

Note that (56) is closely related to the BM equations (32). However, system (56) is still described in terms of  $q$  and  $p$  instead of  $e$  and  $f$ . A representation in terms  $e$  and  $f$  is possible if the Legendre transformation (47) exists. The same condition appears in Method I. The difference between the two methods is that for Method I the transformation from displacements to forces is crucial for the construction of the mixed potential, whereas for Method II it is only necessary to express the system in terms of efforts and flows. In [31], a system of the form (32), but expressed in variables other than efforts and flows, is referred to as a *homonymous* BM system. Furthermore, note that if  $D(q) = D$  is constant, then  $\tilde{Q}(z)$  reduces to

$$\begin{bmatrix} -D^{-1} & 0 \\ 0 & \nabla_q^2 \mathcal{V}(q) \end{bmatrix} \sim \begin{bmatrix} \text{"masses"} & 0 \\ 0 & \text{"springs"} \end{bmatrix}^{-1}.$$

### Example 3 Revisited

Consider again the inverted pendulum on a cart of Figure 6. The kinetic co-energy in terms of the generalized coordinates

$q = \text{col}(x, \theta)$  is found in (25). The associated generalized mass matrix equals

$$D(\theta) = \begin{bmatrix} M_c + M_b & M_b l \cos(\theta) \\ M_b l \cos(\theta) & M_b l^2 \end{bmatrix}. \quad (59)$$

The potential energy associated with the bob is

$$\mathcal{V}(\theta) = M_b g l \cos(\theta), \quad (60)$$

and

$$B(\theta, \dot{\theta}) = \begin{bmatrix} 0 & -M_b l \dot{\theta} \sin(\theta) \\ 0 & 0 \end{bmatrix}.$$

Let us first study the application of Method I.

### Method I

Since the applicability of the first method relies on the existence of the Legendre transformation (47) we directly run into trouble because the gradient of the potential energy with respect to the  $x$  coordinate is zero. Hence, for this system we cannot derive BM equations with (50) and (51). On the other hand, suppose that the cart is attached to a linear spring with compliance  $C_x$ . In this case, an additional term  $(1/2)C_x^{-1}x^2$  is added to the potential energy. Now, under the additional assumption that the motion of the bob is restricted to the interval  $-\pi/2 < \theta < \pi/2$ , the mappings

$$e_{c_x} = \nabla_x \mathcal{V}(x, \theta), \quad e_{c_\theta} = \nabla_\theta \mathcal{V}(x, \theta)$$

are locally invertible, hence allowing for the definition of a co-energy function  $\mathcal{V}^*(e_c)$ . Thus, the generalized coordinates can be expressed in terms of the generalized forces as  $x = C_x e_{c_x}$  and

$$\theta = \arcsin\left(-\frac{e_{c_\theta}}{M_b g l}\right). \quad (61)$$

Substitution of (61) into (49) yields a local BM description with mixed-potential function (50) and  $Q$ -matrix (51), where the incremental compliance matrix takes the form

$$C(e_{c_\theta}) = \begin{bmatrix} C_x & 0 \\ 0 & -\frac{1}{\sqrt{(M_b g l)^2 - e_{c_\theta}^2}} \end{bmatrix}.$$

In the limit  $C_x \rightarrow \infty$  we obtain the equations of motion for the original system [29].

### Method II

Observing that the conjugate momenta are determined by  $p = D(q)f$ , with  $f = \text{col}(\dot{x}, \dot{\theta})$ , we directly deduce the homonymous BM description by substituting (59) and (60) into (57) and (58), respectively. In this case there is no restriction on the angle [31]. On the other hand, to translate the result into a canonical BM description in terms of efforts and flows, we need to impose the assumptions of Method I. ■

### General Nonlinear Systems

In the above developments we use the structural physical information to construct mixed-potential functions, whether

in terms of efforts and flows or a set of aberrant variables leading to homonymous BM equations. On a more abstract level the underlying mechanism for generating a mixed-potential function is Poincaré's lemma [32]. For autonomous nonlinear systems of the form

$$\dot{z} = F(z), \quad (62)$$

with state variables  $z \in \mathbb{R}^n$ , this lemma states that given that  $F: \mathbb{R}^n \rightarrow \mathbb{R}^n$  is a differentiable function, there exists a  $\mathcal{P}: \mathbb{R}^n \rightarrow \mathbb{R}$  such that  $F(z) = \nabla_z \mathcal{P}(z)$  if and only if

$$\nabla_z F(z) = [\nabla_z F(z)]^\top.$$

We use this result to construct a BM description as follows. If we can find a nonsingular matrix  $Q: \mathbb{R}^n \rightarrow \mathbb{R}^{n \times n}$  such that

$$\nabla_z(Q(z)F(z)) = [\nabla_z(Q(z)F(z))]^\top, \quad (63)$$

then the system (62) can equivalently be written as

$$Q(z)\dot{z} = \nabla_z \mathcal{P}(z), \quad (64)$$

where

$$\mathcal{P}(z) = \int [Q(z)F(z)]^\top dz. \quad (65)$$

Depending on the choice of  $Q(z)$  and the type of state variables  $z$ , these expressions may lead to either a canonical or a homonymous BM description. Some guidelines regarding the choice of  $Q(z)$  are provided in [32] and [33].

### Example 9: Rigid Body Motion

In the absence of external torques, the Euler equations for the rotational dynamics of a rigid body about its center of mass are given by

$$\begin{aligned} I_1 \dot{\omega}_1 &= (I_2 - I_3)\omega_2\omega_3, \\ I_2 \dot{\omega}_2 &= (I_3 - I_1)\omega_3\omega_1, \\ I_3 \dot{\omega}_3 &= (I_1 - I_2)\omega_1\omega_2, \end{aligned} \quad (66)$$

where  $\omega_k$  and  $I_k$ , for  $k = 1, 2, 3$ , are the angular velocities of the body resolved in the axis of a frame fixed to the body, and the principle moments of inertia, respectively.

Letting

$$Q = \begin{bmatrix} \frac{I_1}{I_2 - I_3} & 0 & 0 \\ 0 & \frac{I_2}{I_3 - I_1} & 0 \\ 0 & 0 & \frac{I_3}{I_1 - I_2} \end{bmatrix},$$

under the assumption that  $I_1 > I_2 > I_3 > 0$ , and  $\omega = \text{col}(\omega_1, \omega_2, \omega_3)$ , the BM equations of (66) are given by

$$Q\dot{\omega} = \nabla_\omega \mathcal{P}(\omega),$$

with mixed-potential function  $\mathcal{P}(\omega) = \omega_1\omega_2\omega_3$ .

The Euler equations in the form (66) do not admit a Lagrangian or a co-Lagrangian description. A classical way to circumvent the difficulties occurring in the Lagrangian approach is to use a description of the orientation of the body

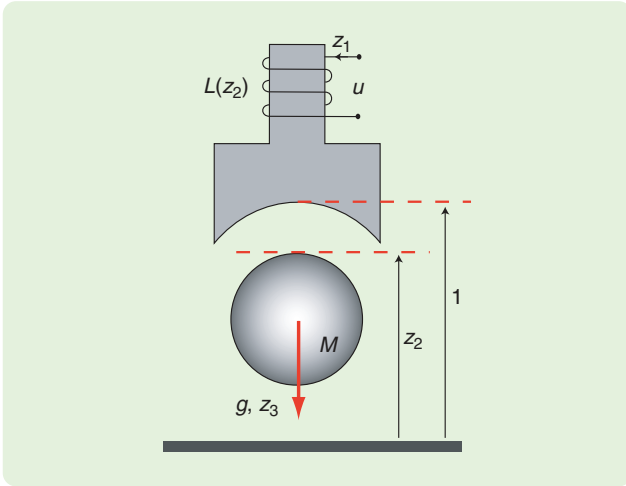

**FIGURE 14** A levitated ball system. This system consists of an iron ball in a vertical magnetic field, which is created by a single electromagnet. The electromagnetic force created by the electromagnet is used to counteract the effect of the gravitational force.

in terms of three Euler angles and their associated velocities. However, this procedure yields six differential equations instead of three. Alternatively, the Euler equations (66) can be described by the Euler-Poincaré equations [34]. ■

In the next example, the above procedure extends to systems with independent inputs.

### Example 10: A Magnetic Levitation System

Consider the system of Figure 14 consisting of an iron ball in a vertical magnetic field created by a single electromagnet. The voltage  $u$  applied to the electromagnet can be considered as the control input. Adopting the standard modeling assumptions of unsaturated flux [35], the dynamic model of the system can be written in the form

$$\dot{z} = F(z, u),$$

with  $z = \text{col}(z_1, z_2, z_3)$  and

$$F(z, u) = \begin{bmatrix} -\frac{R}{\alpha}(1 - z_2)z_1 + u \\ \frac{z_3}{M} \\ \frac{z_1^2}{2\alpha} - Mg \end{bmatrix}. \quad (67)$$

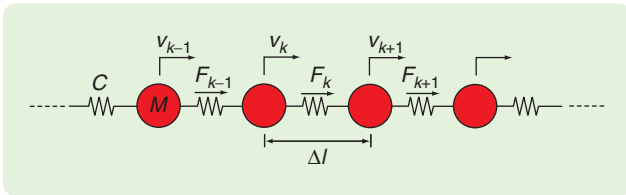

**FIGURE 15** Toward distributed-parameter systems. This example illustrates the salient features of the transition from a lumped-parameter to a distributed-parameter system given by an infinitely long chain of equal mass points  $M$  connected by linear massless springs with compliance  $C$  and natural unstretched length  $\Delta l$ . In the limit  $\Delta l \rightarrow 0$ , the force (effort)  $F_k(t)$  and velocity (flow)  $v_k(t)$ , with integer index  $k$  identifying the movement of the  $k$ -th mass and stiffness, become continuous force and velocity fields  $F(z, t)$  and  $v(z, t)$ , respectively, with continuous spatial coordinate  $z$ .

Here  $z_1$  represents the flux linkage associated with the electromagnet,  $z_2$  is the ball displacement, and  $z_3$  is its momentum. Furthermore,  $M$  is the mass of the ball,  $R$  is the coil resistance,  $\alpha$  is a positive constant that depends on the number of coil turns, and  $g$  is the acceleration due to gravity.

By letting [33]

$$Q(z) = \begin{bmatrix} -\frac{1-z_2}{\alpha} & -\frac{z_1}{\alpha} & 0 \\ \frac{z_1}{\alpha} & 0 & 0 \\ 0 & 0 & -\frac{1}{M} \end{bmatrix}, \quad (68)$$

the system (67) can be written as (64), with

$$\mathcal{P}(z) = \frac{R(1 - z_2)^2 z_1^2}{2\alpha^2} - \frac{(1 - z_2)z_1}{\alpha} u + \frac{z_3}{M} \left( Mg - \frac{z_1^2}{2\alpha} \right). \quad (69)$$

To show that (69) is indeed a power function of a form similar to (28), we first note that the current (electrical flow) through the coil of the electromagnet equals  $L^{-1}(z_2)z_1$ , with displacement-modulated inductance  $L(z_2) = \alpha(1 - z_2)^{-1}$ , and  $M^{-1}z_3$  equals the velocity (mechanical flow) of the ball. The term  $(1/2)\alpha^{-1}z_1^2$  represents the force of electrical origin (electrical effort) acting on the ball, and  $Mg$  represents the gravitational force (mechanical effort) acting on the ball. Hence, the terms on the right-hand side of (69) can be identified as, respectively, the electrical content associated with the resistance of the coil and the power supplied by the voltage source, the mechanical content associated with the power “supplied” by gravity, and the power delivered from the electromagnet to the ball. Since the state variables of the system are neither efforts nor flows, the present description belongs to the class of homonymous BM equations. A canonical description does not exist because there is no potential co-energy storage in the system. ■

## DISTRIBUTED-PARAMETER SYSTEMS

We now briefly discuss how the mixed potential can be used for distributed-parameter systems. We begin by considering a one-dimensional chain consisting of  $n$  identical point masses  $M$  connected to each other with identical ideal springs with compliance  $C$  (see Figure 15). At rest the equilibrium distance between neighboring masses is  $\Delta l$ . The velocity (flow) in the  $z$ -direction associated with the  $k$ th mass is denoted by  $v_k$ , and the force (effort) associated with the  $k$ th spring is  $F_k$ . A mixed-potential for this system is given by

$$\mathcal{P} = - \sum_{k=1}^n F_k(v_{k+1} - v_k). \quad (70)$$

Let us rewrite (70) as

$$\mathcal{P} = \Delta l \sum_{k=1}^n \mathcal{P}_k,$$

where

$$\mathcal{P}_k = -F_k \left( \frac{v_{k+1} - v_k}{\Delta l} \right)$$

is the mixed-potential associated to the  $k$ th subsystem.

Now, suppose that  $n \rightarrow \infty$ , while at the same time the springs become infinitesimally short according to

$$\Delta l \rightarrow dz, \quad \frac{M}{\Delta l} \rightarrow \frac{dM}{dz} = \mu, \quad \frac{C}{\Delta l} \rightarrow \frac{dC}{dz} = \frac{1}{E},$$

and

$$\frac{v_{k+1} - v_k}{\Delta l} \rightarrow \frac{\partial v}{\partial z} =: \nabla_z v,$$

where the constants  $\mu$  and  $E$  are the linear mass density and Young's modulus, respectively [17]. A direct consequence of this transition is that the number of degrees of freedom goes from a finite number  $n$  to infinity, where the infinitesimal mass points are now identified by a continuous spacial parameter  $z \in \mathbb{Z}$ . Hence, the mixed-potential function becomes the functional

$$\mathcal{P}[v, F] = \int_{\mathbb{Z}} \bar{\mathcal{P}}(\nabla_z v, F) dz, \quad (71)$$

with density

$$\bar{\mathcal{P}}(\nabla_z v, F) = -F \nabla_z v. \quad (72)$$

The derivatives of the mixed-potential functional (71) with respect to the distributed flow field  $v(z, t)$  and effort field  $F(z, t)$  are determined by invoking the functional (or variational) derivative playing a role analogous to the gradient of a function. Since the chain is infinitely long, implying that the natural boundary conditions are zero, there is in fact no boundary at all. These derivatives thus reduce to Euler-type equations [36], [37]

$$\delta_{(\bullet)} \mathcal{P} := \nabla_{(\bullet)} \bar{\mathcal{P}} - \nabla_z (\nabla_{(\bullet)z} \bar{\mathcal{P}}). \quad (73)$$

The resulting distributed-parameter BM equations are

$$\begin{bmatrix} -\mu & 0 \\ 0 & E^{-1} \end{bmatrix} \begin{bmatrix} \dot{v} \\ \dot{F} \end{bmatrix} = \begin{bmatrix} \delta_v \mathcal{P} \\ \delta_F \mathcal{P} \end{bmatrix} = \begin{bmatrix} \nabla_z F \\ -\Delta_z v \end{bmatrix}, \quad (74)$$

where  $\dot{v}$  and  $\dot{F}$  must be interpreted as the partial derivatives of  $v$  and  $F$  with respect to time.

Suppose next that the chain has finite length, say one meter, and that at  $z = 0$  an external force  $F_{\text{ext}}$  is applied, whereas at  $z = 1$  the chain is connected to a sliding mass  $M^1$  that is subject to friction with friction coefficient  $R^1$ ; see Figure 16. The mixed-potential then becomes

$$\mathcal{P}[F, v] = - \int_0^1 F \nabla_z v dz + \mathcal{P}^0 + \mathcal{P}^1,$$

where

$$\mathcal{P}^0 = -v^0 F_{\text{ext}}$$

and

$$\mathcal{P}^1 = \frac{R^1}{2} (v^1)^2$$

are referred to as the boundary potentials. In this case the power at both ends of the chain generally differs from zero so that next to the Euler equations (73) we have the natural boundary conditions

$$\delta_{(\bullet)0} \mathcal{P} := \nabla_{(\bullet)0} \mathcal{P}^0 - \nabla_{(\bullet)z} \bar{\mathcal{P}}|_{z=0}, \quad (75)$$

$$\delta_{(\bullet)1} \mathcal{P} := \nabla_{(\bullet)1} \mathcal{P}^1 + \nabla_{(\bullet)z} \bar{\mathcal{P}}|_{z=1}, \quad (76)$$

providing in addition to (74) the equations

$$0 = \delta_{v^0} \mathcal{P} = -F_{\text{ext}} + F^0, \quad (77)$$

$$0 = \delta_{F^0} \mathcal{P}, \quad (78)$$

$$-M^1 \dot{v}^1 = \delta_{v^1} \mathcal{P} = R^1 v^1 - F^1, \quad (79)$$

$$0 = \delta_{F^1} \mathcal{P}. \quad (80)$$

Notice that the form of the mixed-potential functional (71) is not unique since instead of (70) we could equally well start from the discrete mixed-potential

$$\mathcal{P} = \sum_{k=1}^n v_k (F_k - F_{k-1}). \quad (81)$$

In the transition from a discrete to a continuous system, the latter choice replaces the term  $-F \nabla_z v$  in (72) by  $v \nabla_z F$ . In a similar fashion as before, these terms can be interpreted as the instantaneous power density between the "inductive" part of the system  $\Sigma_a$  (including the distributed masses) and the "capacitive" part of the system  $\Sigma_b$  (including the distributed springs). Although both (70) and (81) lead to (74), the latter choice affects the boundary potentials. See [38] and [39] for more details.

It is noteworthy that, from the perspective of the analogy used here, (74), together with the boundary conditions (77)–(78), also describe a lossless electrical transmission line that is driven on one end by a voltage source and on the other end terminated by an inductor in series with a resistor. For a more complete discussion on the application of the concept of mixed-potential to electrical transmission lines, see [36]. A more recent and closely related application of the distributed-parameter BM equations is presented in [40], which considers nonlinear activator-inhibitor equations to describe and control pattern-forming systems.

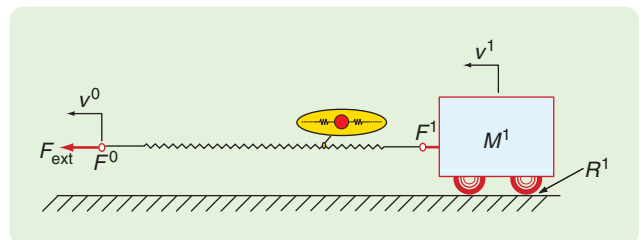

FIGURE 16 Mixed lumped- and distributed-parameter systems. A cart with mass  $M^1$  is pushed or pulled with force  $F_{\text{ext}}$  through a continuous elastic rod. The mass is subject to friction  $R^1$  in the wheels.

## Energy can serve as a lingua franca to facilitate communication among scientists and engineers from different fields.

As another example of a distributed-parameter system we discuss Maxwell's equations [10]. These equations govern the electromagnetic behavior in a medium, say  $\mathbb{V}$ , and can be split into two subsets, namely, Maxwell's curl equations

$$\text{curl } \mathbf{E} = -\dot{\mathbf{B}}, \quad (82)$$

$$\text{curl } \mathbf{H} = \dot{\mathbf{D}} + \mathbf{J}, \quad (83)$$

and Maxwell's divergence equations

$$\text{div } \mathbf{D} = \rho, \quad (84)$$

$$\text{div } \mathbf{B} = 0, \quad (85)$$

in which the magnetic and electric flux densities  $\mathbf{B}$  and  $\mathbf{D}$  are related with the field intensities  $\mathbf{H}$  and  $\mathbf{E}$  through the constitutive relationships depending on the medium. The vector  $\mathbf{J}$  denotes the current density and  $\rho$  denotes the electric charge density. To cast Maxwell's curl equations (82) and (83) into a form similar to (32), we first make the observation that the field intensities  $\mathbf{H}$  and  $\mathbf{E}$  play a role of the flows and efforts in (32). For ease of presentation, we assume that the medium is time and space invariant, but possibly nonlinear such that  $\mathbf{B} = \widehat{\mathbf{B}}(\mathbf{H})$  and  $\mathbf{D} = \widehat{\mathbf{D}}(\mathbf{E})$ . Thus, we focus on developing a BM description of

$$-\mu(\mathbf{H})\dot{\mathbf{H}} = \text{curl } \mathbf{E}, \quad (86)$$

$$\varepsilon(\mathbf{E})\dot{\mathbf{E}} = \text{curl } \mathbf{H} - \mathbf{J}, \quad (87)$$

where  $\mu(\mathbf{H}) := \nabla_{\mathbf{H}}\widehat{\mathbf{B}}(\mathbf{H})$  and  $\varepsilon(\mathbf{E}) := \nabla_{\mathbf{E}}\widehat{\mathbf{D}}(\mathbf{E})$  represent the incremental permeability and incremental permittivity, respectively. Furthermore, we assume that the current density is given by  $\mathbf{J} = \widehat{\mathbf{J}}(\mathbf{E})$ .

Similar to the mechanical mass-spring-damper chain discussed above, the number of degrees of freedom is infinite so that the inductive and capacitive phenomena are identified by the continuous spacial parameters  $x, y, z$ . The system can again be subdivided into subsystems  $\Sigma_a$  and  $\Sigma_b$  associated with the magnetic and electric field phenomena, respectively. The associated mixed-potential functional assumes the form

$$P[\mathbf{H}, \mathbf{E}] = -D^*[\mathbf{E}] + N[\mathbf{H}, \mathbf{E}], \quad (88)$$

where

$$D^*[\mathbf{E}] = \iiint_{\mathbb{V}} \left( \int \widehat{\mathbf{J}}(\mathbf{E}) \cdot d\mathbf{E} \right) dx dy dz$$

represents the total co-content associated with the current density  $\mathbf{J}$ , whereas depending on the boundary conditions

we are left with two possible choices for the total power transfer between  $\Sigma_a$  and  $\Sigma_b$ , that is,

$$N_a[\mathbf{H}, \mathbf{E}] = \iiint_{\mathbb{V}} \mathbf{H} \cdot \text{curl } \mathbf{E} dx dy dz \quad (89)$$

and

$$N_b[\mathbf{H}, \mathbf{E}] = \iiint_{\mathbb{V}} \text{curl } \mathbf{H} \cdot \mathbf{E} dx dy dz. \quad (90)$$

Indeed, the choice  $N = N_a$  imposes the condition that the magnetic field intensity at the boundary is continuous ( $\widehat{\mathbf{n}} \times \mathbf{H} = \mathbf{0}$ , where  $\widehat{\mathbf{n}}$  is the inward normal) and in turn ensures the set of functional derivatives

$$\delta_{\mathbf{H}}P = \text{curl } \mathbf{E}, \quad \delta_{\mathbf{E}}P = \text{curl } \mathbf{H} - \mathbf{J}.$$

Hence, letting  $\mathbf{X} = \text{col}(\mathbf{H}, \mathbf{E})$  represent the field intensity vector, Maxwell's curl equations (86) and (87) define the BM system

$$Q(\mathbf{X})\dot{\mathbf{X}} = \delta_{\mathbf{X}}P(\mathbf{X}), \quad (91)$$

with respect to the indefinite metric

$$Q(\mathbf{X}) = \begin{bmatrix} -\mu(\mathbf{H}) & \mathbf{0} \\ \mathbf{0} & \varepsilon(\mathbf{E}) \end{bmatrix}.$$

The remaining divergence equations (84) and (85) can be considered as algebraic constraints. Together with (91) these constraints establish a set of DAEs.

The same result can be obtained by starting from the possibility  $N = N_b$  accompanied by the assumption that now the tangential electric field intensity at the boundary is continuous ( $\widehat{\mathbf{n}} \times \mathbf{E} = \mathbf{0}$ ). If the boundary is a perfect conductor the latter condition seems natural, but the condition that the magnetic field intensity at the boundary is continuous, associated with the choice  $N = N_a$ , implies an unphysical situation. Furthermore, the specification of either  $\widehat{\mathbf{n}} \times \mathbf{E} = \mathbf{0}$  or  $\widehat{\mathbf{n}} \times \mathbf{H} = \mathbf{0}$  implies that the net energy flow across the boundary is zero, meaning that the system is isolated. In a similar fashion as with the previous example, these conditions can be circumvented by adding appropriate boundary potentials. For more details, see [38].

### CONCLUDING REMARKS

#### Energy Versus Power Variables

A practical advantage of the BM framework is that the system variables are directly expressed in terms of easily measurable quantities, such as currents, voltages, velocities,

forces, volume flows, pressures, or temperatures. This is especially the case when the framework is used for controller design where signals need to be measured for feedback. The Lagrangian, co-Lagrangian, and Hamiltonian formulation normally involve generalized displacements and momenta, which in many cases cannot be measured directly.

### Spurious Constants

In [41] the modeling of the mass-spring system of Figure 3 (with  $R = 0$ ) is treated. The modeling based on efforts and flows is critically discussed in [41], which notes that a spurious constant is needed to obtain the correct physics. However, when the spurious constant is not taken into account, the assumption of a reference position is always present. This fact can be seen better if the spring is not attached to the wall with zero velocity but to another moving mass yielding a mass-spring-mass system. In that case a reference position is necessary, and the difference in positions of both masses

must be known to derive the equations of motion correctly. On the other hand, in the present article we have seen that a translational mass corresponds to a relationship between velocity and momentum, whereas a translational spring corresponds to a relationship between displacement and force. In a behavioral parlance it seems therefore most natural that, when we want to connect the mass to the spring by equating their displacements, a manifest variable assignment involving the displacement associated with the spring is selected, that is,  $w = x_K$ . Indeed, for the mass-spring system of Figure 3, elimination of the latent variables yields a second-order differential equation that precisely coincides with the differential equation for  $w$ , that is, (22) [41]. The selection of the manifest variables depends on the modeler's choice.

### Port-Hamiltonian Systems

In this article we have explained only the classical Hamiltonian setting. However, in recent years many efforts have

## Applications to Analysis and Control

As outlined in "History of the Mixed-Potential Function," one of the main motivations behind the construction of the mixed-potential function concerns its use in determining Lyapunov-based stability criteria for nonlinear electrical circuits. A strong feature of the mixed-potential function method is that it can also be applied to circuits with negative resistors. Several theorems are available, each imposing particular restrictions on the type of nonlinearity allowed in the circuit [19]. By analogy these theorems can be carried over verbatim to the engineering domains considered in the present article. We thus highlight some recent developments that take the mixed-potential as a starting point.

The energy-based Lagrangian and Hamiltonian modeling methods have resulted in a renewed attention for control design based on energy called passivity-based control (PBC); see [4], [5], and [35]. The control objective is achieved through an energy shaping and damping injection process to modify the energy and dissipation structure of the system. From a network-theoretic perspective, the damping injection process yields controllers that forces the closed-loop dynamics to behave as if artificial resistors (the control parameters) are added to the system. These energy-based control methods, however, do not specify where to inject damping and how to tune the controller. Using BM theory, and in particular theorems S1, S2, and S3 from "History of the Mixed-Potential Function" provides a tool for control design with damping injection tuning rules [S27].

For more industrially relevant applications of the BM theory we refer to [40] and [S28]. BM theory is used in [40] to investigate the stability of large arrays of actuators, whereas [S28] applies the BM theory for controller tuning of a standard industrial power converter.

There are several ways to achieve energy shaping. In the case of energy-balancing PBC, the energy function assigned to the

closed-loop system is the difference between the total energy of the system and the energy supplied by the controller [35]. However, the energy-balancing control method is stymied by the *dissipation obstacle*—a term that refers to the existence of resistive elements whose energy dissipation does not vanish at the desired equilibrium point. The dissipation obstacle occurs, for instance, in electrical and electromechanical systems that have equilibrium states with currents or velocities not equal to zero. On the other hand, a translational mechanical system in equilibrium always has its velocities equal to zero, and hence does not suffer from the dissipation obstacle. Energy-balancing control cannot be applied to systems that suffer from the dissipation obstacle. Based on BM theory and the mixed-potential function a *power-shaping* method is developed in [S29] and [S30]. This method shapes the mixed-potential function, and does not suffer from the dissipation obstacle. Furthermore, in some cases the power-shaping method yields better performance than energy-shaping methods, and therefore it is also interesting to apply power shaping to mechanical and other systems. The multidomain modeling approach of the present article has led to the extension of the power-shaping method to general nonlinear systems [32], [33].

## REFERENCES

- [S27] D. Jeltsema and J. M. A. Scherpen, "Tuning of passivity-preserving controllers for switched-mode power converters," *IEEE Trans. Automat. Contr.*, vol. 49, no. 8, pp. 1333–1344, Aug. 2004.
- [S28] M. M. J. de Vries, M. J. Kransse, M. Liserre, V. G. Monopoli, and J. M. A. Scherpen, "Passivity based harmonic control through series/parallel damping of an H-bridge rectifier," in *Proc. IEEE Int. Symp. Industrial Electronics*, Vigo, Spain, June 2007, pp. 3385–3390.
- [S29] D. Jeltsema, R. Ortega, and J. M. A. Scherpen, "On passivity and power-balance inequalities of nonlinear RLC circuits," *IEEE Trans. Circuits Syst. I*, vol. 50, no. 9, pp. 1174–1179, Sept. 2003.
- [S30] R. Ortega, D. Jeltsema, and J. M. A. Scherpen, "Power shaping: A new paradigm for stabilization of nonlinear RLC circuits," *IEEE Trans. Automat. Contr.*, vol. 48, no. 10, pp. 1762–1767, Oct. 2003.



## In multidomain Lagrangian and Hamiltonian modeling it is necessary to distinguish between two types of energies, energy and co-energy.

been undertaken to generalize the classical Hamiltonian formalism to the port-Hamiltonian formalism, which has turned out to be a powerful framework to model and control many physical systems based on energy considerations; see [5] and later work. In some cases the port-Hamiltonian framework, with a basis originating in the classical mechanical literature, is more convenient, while in other cases the BM framework, with a basis in electrical circuit theory, is more convenient. For instance, occurrence of the dissipation obstacle in some electrical circuit models hinders the application of some PBC techniques in the port-Hamiltonian framework, whereas application of the power-shaping method based on the BM models circumvents these problems; see “Applications to Analysis and Control.” On the other hand, the existence of the mixed potential strongly depends on the integrability of the constitutive relationships of the interconnection and resistive structure. Typical examples of systems that cannot be described in a BM fashion are systems containing essential gyrators [42].

### Inclusion of Memristive Phenomena

We have seen that each engineering domain rests on four basic elements, namely, resistive, inductive, capacitive, and memristive elements. Although we have highlighted the main properties of the memristor, we did not discuss how memristive phenomena can be included in the energy- and power-based frameworks. To suggest how a system exhibiting memristive phenomena can be included, let us consider an example. For that, suppose that the damper  $R$  in the mechanical system of Figure 5(a) is replaced by a damper  $D$  whose constitutive relationship depends on its relative displacement, such as a tapered dashpot [43]. Denoting this relationship by  $p_D = \hat{p}_D(x_D)$ , the corresponding state function is the *action* (see “State Functions”) defined by

$$\mathcal{A}(x_D) = \int_0^{x_D} \hat{p}_D(q) dq.$$

Hence, starting from the Lagrangian equations we obtain, with Lagrangian (9) and by noting that  $x_D = x$ , the equations of motion

$$\frac{d}{dt} \nabla_v \mathcal{L}(x, v) - \nabla_x \mathcal{L}(x, v) = - \frac{d}{dt} \nabla_x \mathcal{A}(x).$$

However, in passing on to the BM equations it is clear that the memristive effect cannot be included in the mixed-potential function. Instead, the BM equations need to be

augmented with the addition of the action in a similar fashion as with the Lagrangian formulation above, that is,

$$\begin{aligned} -M\dot{v} - \frac{d}{dt} \nabla_x \mathcal{A}(x)|_{x=CF} &= \nabla_v \mathcal{P}(v, F), \\ CF &= \nabla_F \mathcal{P}(v, F), \end{aligned}$$

with  $\mathcal{P}(v, F) = Fv$ . As pointed out in [43], it is a coincidence that for this particular system it is possible to represent the tapered dashpot as a modulated resistor since its displacement is the same as the displacement of the spring and thus proportional to the force in the spring ( $x = CF$ ). In general, the generalized momenta and displacements of the memristive elements in a system are independent from the generalized momenta and displacements of the inductive and capacitive elements. Although a memristor is a purely dissipative element, it is also a dynamic element since the associated Ohmian laws are expressed in terms of differential equations. Consequently, the order of complexity of a system is in general equal to the total number of inductive, capacitive, and memristive elements [22]. For an extensive treatment in the electrical domain on how memristive elements can be included in a Lagrangian or BM description the reader is referred to [44]. Since a memristor is described in terms of generalized momenta and displacements, its most natural habitat is the Hamiltonian formulation (see Figure 4) and all of its generalizations. Current research is devoted to studying memristive phenomena in the port-Hamiltonian framework. See [45] for some preliminary results.

### ACKNOWLEDGMENTS

The authors like to thank all researchers with whom they have collaborated on the topic of this article. In particular, we like to acknowledge the collaborations and discussions with Alessandro De Rinaldis, Eloísa García-Canseco, Romeo Ortega, and Arjan van der Schaft.

### AUTHOR INFORMATION

**Dimitri Jeltsema** (d.jeltsema@tudelft.nl) received the B.Eng. degree in electrical engineering from the Rotterdam University of Applied Science, The Netherlands, and the M.Sc. degree in systems and control engineering from the University of Hertfordshire, United Kingdom, in 1996 and 2000, respectively. In 2005 he received the Ph.D. degree (with honors) from Delft University of Technology, The Netherlands. From 2005 to 2007 he was a postdoctoral researcher and lecturer at the Delft Center for Systems and Control. Currently he is an assistant professor at the Optimization and

Systems Theory group of the Delft Institute of Applied Mathematics. His research interests include modeling and control of nonlinear circuits and systems. He can be contacted at Delft Institute of Applied Mathematics, Delft University of Technology, Mekelweg 4, 2628 CD Delft, The Netherlands.

**Jacquelin M.A. Scherpen** (j.m.a.scherpen@rug.nl) received the M.Sc. and Ph.D. degrees in applied mathematics from the University of Twente, The Netherlands, in 1990 and 1994, respectively, in the field of systems and control. From 1994 to 2006 she was at Delft University of Technology, The Netherlands, as a postdoctoral researcher and as an assistant and associate professor in the Faculty of Electrical Engineering, Computer Science and Mathematics and the Faculty of Mechanical, Maritime and Materials Engineering. Since September 2006 she has been a professor at the University of Groningen in the Industrial Technology and Management Department of the Faculty of Mathematics and Natural Sciences. She has held visiting research positions at the Université de Compiègne, France, SUPELEC, Gif-sur-Yvette, France, the University of Tokyo, Japan, and Old Dominion University, VA, USA. She served as an associate editor of *IEEE Transactions on Automatic Control*, and the *International Journal of Robust and Nonlinear Control*. Currently, she is an associate editor of the *IMA Journal of Mathematical Control and Information*. Her research interests include nonlinear model reduction methods, realization theory, nonlinear control methods, as well as modeling and control of physical systems with applications to electromechanical systems.

## REFERENCES

- [1] R. Abraham and J. E. Marsden, *Foundations of Mechanics*, 2nd ed. Redwood City, CA: Benjamin/Cummings, 1978.
- [2] R. A. Layton, *Principles of Analytical System Dynamics*. New York: Springer-Verlag, 1998.
- [3] A. G. J. MacFarlane, *Dynamical System Models*. George G. London: Har-rap & Co., 1970.
- [4] R. Ortega, A. Loria, P. J. Nicklasson, and H. Sira-Ramírez, *Passivity-Based Control of Euler-Lagrange Systems; Mechanical, Electrical and Electromechanical Applications*. New York: Springer-Verlag, 1998.
- [5] A. J. Van der Schaft, *L<sub>2</sub>-Gain and Passivity Techniques in Nonlinear Control*. New York: Springer-Verlag, 2000.
- [6] A. M. Bloch, N. E. Leonard, and J. E. Marsden, "Controlled Lagrangians and the stabilization of mechanical systems. I. The first matching theorem," *IEEE Trans. Automat. Contr.*, vol. 45, no. 12, pp. 2253–2270, 2000.
- [7] H. Nijmeijer and A. J. Van der Schaft, *Nonlinear Dynamical Control Systems*. New York: Springer-Verlag, 1990.
- [8] K. Fujimoto and T. Sugie, "Canonical transformation and stabilization of generalized Hamiltonian systems," *Syst. Control Lett.*, vol. 42, no. 3, pp. 217–227, Mar. 2001.
- [9] E. C. Cherry, "Some general theorems for nonlinear systems possessing reactance," *Philos. Mag., Ser. 7*, vol. 42, no. 333, pp. 1161–1177, Oct. 1951.
- [10] P. Hammond, *Energy Methods in Electromagnetism*. Oxford: Clarendon, 1986.
- [11] A. Kugi, *Nonlinear Control Based on Physical Models*. New York: Springer-Verlag, 2001.
- [12] O. K. Mawardi, "On the concept of coenergy," *J. Franklin Inst.*, vol. 264, no. 1, pp. 313–332, 1957.
- [13] H. M. Paynter, *Analysis and Design of Engineering Systems*. Cambridge, MA: MIT Press, 1961.
- [14] A. Preumont, *Mechatronics: Dynamics of Electromechanical and Piezoelectric Systems*. New York: Springer-Verlag, 2006.
- [15] B. Tabarrok and F. P. J. Rimrott, *Variational Methods and Complementary Formulations in Dynamics*. Norwell, MA: Kluwer, 1994.
- [16] L. Rayleigh, "Some general theorems relating to vibrations," in *Proc. London Mathematical Society*, June 1873, pp. 357–368.
- [17] H. Goldstein, *Classical Mechanics*, 2nd ed. Reading, MA: Addison-Wesley, 1980.
- [18] W. Millar, "Some general theorems for nonlinear systems possessing resistance," *Philos. Mag., Ser. 7*, vol. 42, no. 333, pp. 1150–1160, Oct. 1951.
- [19] R. K. Brayton and J. K. Moser, "A theory of nonlinear networks I," *Q. Appl. Math.*, vol. 22, no. 1, pp. 1–33, Apr. 1964.
- [20] R. K. Brayton and J. K. Moser, "A theory of nonlinear networks II," *Q. Appl. Math.*, vol. 22, no. 2, pp. 81–104, July 1964.
- [21] P. J. Gawthrop and G. P. Bevan, "Bond-graph modeling," *IEEE Control Syst. Mag.*, vol. 27, no. 2, pp. 24–45, 2007.
- [22] L. O. Chua, "Memristor, the missing circuit element," *IEEE Trans. Circuit Theory*, vol. 18, no. 2, pp. 507–519, Sept. 1971.
- [23] D. B. Strukov, G. S. Snider, D. R. Stewart, and R. S. Williams, "The missing memristor found," *Nature*, vol. 453, pp. 80–83, May 2008.
- [24] J. Casey, "Geometrical derivation of Lagrange's equations for a system of particles," *Am. J. Phys.*, vol. 62, no. 9, pp. 836–847, Sept. 1994.
- [25] J. O. Flower and F. J. Evans, "Derivation of certain nonlinear circuit equations," *Electron. Lett.*, vol. 3, no. 6, p. 265, 1967.
- [26] L. O. Chua and N. N. Wang, "Complete stability of autonomous reciprocal nonlinear networks," *J. Circuit Theory Appl.*, vol. 6, pp. 211–241, 1978.
- [27] K. M. Hangos, J. Bokor, and G. Szederkényi, *Analysis and Control of Nonlinear Process Systems*. London: Springer-Verlag, 2004.
- [28] L. Weiss, W. Mathis, and L. Trajkovic, "A generalization of Brayton-Moser's mixed-potential function," *IEEE Trans. Circuits Syst. I*, vol. 45, no. 4, pp. 423–427, Apr. 1998.
- [29] A. De Rinaldis and J. M. A. Scherpen, "An electrical interpretation of mechanical systems via the pseudo-inductor in the Brayton-Moser equations," in *Proc. IEEE Conf. Decision and Control and European Control Conf.*, Seville, Spain, Dec. 2005, pp. 5983–5988.
- [30] A. De Rinaldis, J. M. A. Scherpen, and R. Ortega, "Towards power-based control strategies for a class of nonlinear mechanical systems," in *Proc. Lagrangian and Hamiltonian Methods for Nonlinear Control 2006*, Bullo, Francesco, K. Fujimoto, Eds. Springer, vol. 366, pp. 123–133.
- [31] D. Jeltsema and J. M. A. Scherpen, "A power-based description of standard mechanical systems," *Syst. Control Lett.*, vol. 56, no. 5, pp. 349–356, 2007.
- [32] E. García-Canseco, R. Ortega, J. M. A. Scherpen, and D. Jeltsema, "Power shaping control of nonlinear systems: A benchmark example," in *Proc. Lagrangian and Hamiltonian Methods for Nonlinear Control 2006*, Bullo, Francesco, K. Fujimoto, Eds. Springer, vol. 366, pp. 135–146.
- [33] E. García-Canseco, D. Jeltsema, J. M. A. Scherpen, and R. Ortega, "Power-based control of physical systems: Two case studies," in *Proc. 17th IFAC World Congress*, Seoul, Korea, July 2008, pp. 2556–2562.
- [34] J. E. Marsden and T. Ratiu, *Introduction to Mechanics and Symmetry*. New York: Springer-Verlag, 1999.
- [35] R. Ortega, A. J. van der Schaft, I. Mareels, and B. M. Maschke, "Putting energy back in control," *IEEE Control Syst. Mag.*, vol. 21, no. 2, pp. 18–33, 2001.
- [36] R. K. Brayton and W. L. Miranker, "A stability theory for nonlinear mixed-initial boundary value problems," *Arch. Rat. Mech. Anal.*, vol. 17, no. 5, pp. 358–376, Dec. 1964.
- [37] R. Courant and D. Hilbert, *Methods of Mathematical Physics*, vol. I. New York: Interscience, 1953.
- [38] D. Jeltsema and A. J. van der Schaft, "Pseudo-gradient and Lagrangian boundary control formulation of electromagnetic fields," *J. Phys. A: Math. Theor.*, vol. 40, pp. 11627–11643, 2007.
- [39] D. Jeltsema and A. J. van der Schaft, "Lagrangian and Hamiltonian formulation of transmission line systems with boundary energy flow," *Rep. Math. Phys.*, vol. 63, no. 1, pp. 55–74, 2009.
- [40] E. W. Justh and P. S. Krishnaprasad, "Pattern-forming systems for control of large arrays of actuators," *J. Nonlinear Sci.*, vol. 11, pp. 239–277, 2001.
- [41] J. C. Willems, "The behavioral approach to open and interconnected systems," *IEEE Control Syst. Mag.*, vol. 27, no. 6, pp. 46–99, 2007.
- [42] P. C. Breedveld, "Stability of rigid body rotation from a bond graph perspective," *Simulat. Model. Pract. Theor.*, vol. 17, pp. 92–106, 2009.
- [43] G. F. Oster and D. M. Auslander, "The memristor: A new bond graph element," *Trans. ASME Dyn. Syst. Control*, vol. 94, no. 3, pp. 249–252, 1973.
- [44] M. M. Milić and L. A. Novak, "Formulation of equations in terms of scalar functions for lumped non-linear networks," *Int. J. Circuit Theor. Appl.*, vol. 9, pp. 15–32, 1981.
- [45] D. Jeltsema, "Port-Hamiltonian formulation of physical systems containing memristors," in *Proc. 6th Vienna Int. Conf. Mathematical Modelling (MathMod 2009)*, Vienna, Austria, 2009.

