

Multifunctional Cooling Garment for Space Suit Environmental Control

Michael Izenon,¹ Weibo Chen,² Scott Phillips,³ and Ariane Chepko⁴
Creare LLC, Hanover, NH

Grant Bue⁵
NASA Lyndon B. Johnson Space Center, Houston, TX

and

Janet Ferl⁶ and Daniel Cencer⁷
ILC Dover LP, Frederica, DE

Future manned space exploration missions will require space suits with capabilities beyond the current state of the art. Portable Life Support Systems for these future space suits face daunting challenges, since they must maintain healthy and comfortable conditions inside the suit for long-duration missions while minimizing weight and water venting. We have demonstrated the feasibility of an innovative, multipurpose garment for thermal and humidity control inside a space suit pressure garment that is simple, rugged, compact, and lightweight. The garment is based on a conventional liquid cooling and ventilation garment (LCVG) that has been modified to directly absorb latent heat as well as sensible heat. This hybrid garment will prevent buildup of condensation inside the pressure garment, prevent loss of water by absorption in regenerable CO₂ removal beds, and conserve water through use of advanced lithium chloride absorber/radiator (LCAR) technology for nonventing heat rejection. We have shown the feasibility of this approach by sizing the critical components for the hybrid garment, developing fabrication methods, building and testing a proof-of-concept system, and demonstrating by test that its performance is suitable for use in space suit life support systems.

Nomenclature (Lynne, please alphabetize)

ECG	=	Environmental control garment
SEAR	=	Space evaporator-absorber-radiator
LCVG	=	Liquid cooling and ventilation garment
LCAR	=	Lithium chloride absorber/radiator
EMU	=	Extravehicular mobility unit
SWME	=	Spacesuit water membrane evaporator

¹ Principal Engineer, 16 Great Hollow Road, Hanover, NH, AIAA Senior Member.

² Senior Engineer, 16 Great Hollow Road, Hanover, NH.

³ Project Engineer, 16 Great Hollow Road, Hanover, NH.

⁴ Project Engineer, 16 Great Hollow Road, Hanover, NH.

⁵ Aerospace Technologist, 2101 NASA Parkway, Houston, TX, 77058/Mail Stop EC2.

⁶ Design Engineering Manager, Space Suit Assembly, One Moonwalker Road, Frederica, DE, AIAA Senior Member

⁷ **Insert Job Title, Department Name**, One Moonwalker Road, Frederica, DE,.

EVA = Extravehicular activity
 ECDG = Environmental control and dehumidification garment

I. Introduction

Space suits need a system to control the environment inside the pressure garment and maintain comfortable and healthy conditions. Future space exploration will call for frequent EVAs throughout long-duration missions far from Earth, introducing new challenges for space suit life support systems. This paper describes an innovative thermal and humidity control system designed to meet requirements for future exploration missions—particularly water conservation and minimization of condensation inside the pressure garment. The key elements are an Environmental Control Garment (ECG), which is worn by the astronaut and coupled to a Space Evaporator/Absorber Radiator (SEAR) subsystem (Figure 1). The ECG is a hybrid garment that combines the current functionality of the liquid cooling and ventilation garment (LCVG) with the water vapor-absorbing capabilities demonstrated by Creare’s water-permeable latent cooling panels. In the ECG, the separate latent cooling panels are replaced with an array of small, water vapor-permeable tubes that are woven into the LCVG. These tubes selectively allow water vapor from the suit ventilation gas to flow through the tubes to the lithium chloride absorber radiator (LCAR) where it is absorbed. The heat generated by condensation and absorption of the water vapor radiates to space. The ECG/SEAR system maintains a dry environment inside the pressure garment; removes water vapor from the ventilation stream, reducing water lost to CO₂ removal beds; and adds very little bulk and mass to the existing LCVG.

This paper describes work to prove the feasibility of the ECG/SEAR system through analysis, proof-of-concept testing, and conceptual design. We specified latent cooling requirements for current and future space suits, then developed analysis models to size the microtube array and predict its performance. We developed fabrication methods and built a proof-of-concept ECG (Figure 2), then measured its performance under conditions that simulate operation in a space suit. Results were consistent with predictions of the design models. We developed a concept design for an ECG that integrates with an LCVG, in which latent cooling tubes are woven into the garment in high-perspiration locations and manifold tubes are routed with ventilation tubes to minimize effects on crew comfort.

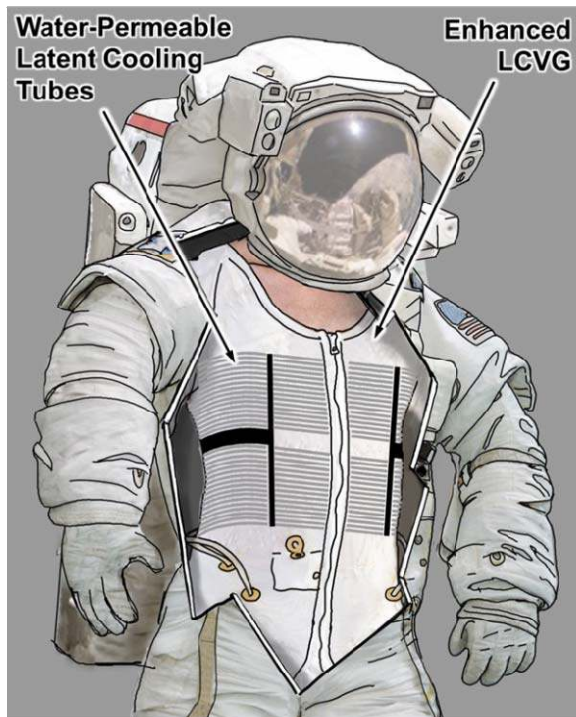

(a) Water-permeable tubes are added to the ECG alongside the liquid cooling tubes

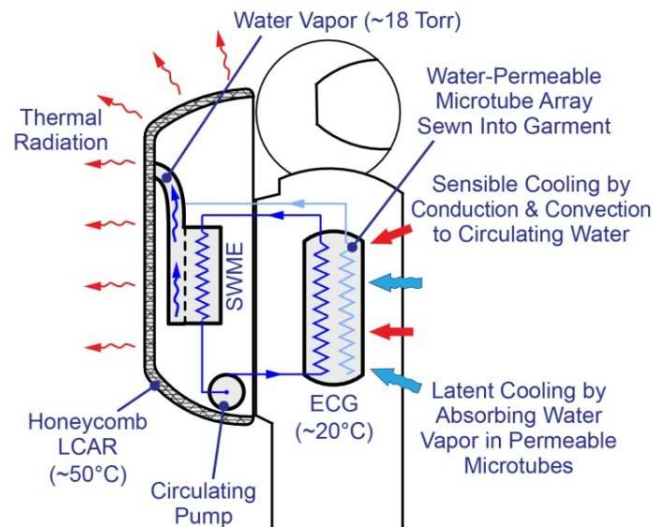

(b) The ECG operates as part of a Space Evaporator/Absorber Radiator (SEAR) System

Figure 1. Creare's Environmental Control Garment (ECG) Adds Direct Water Vapor Absorption Capability to a Conventional Liquid Cooling and Ventilation Garment.

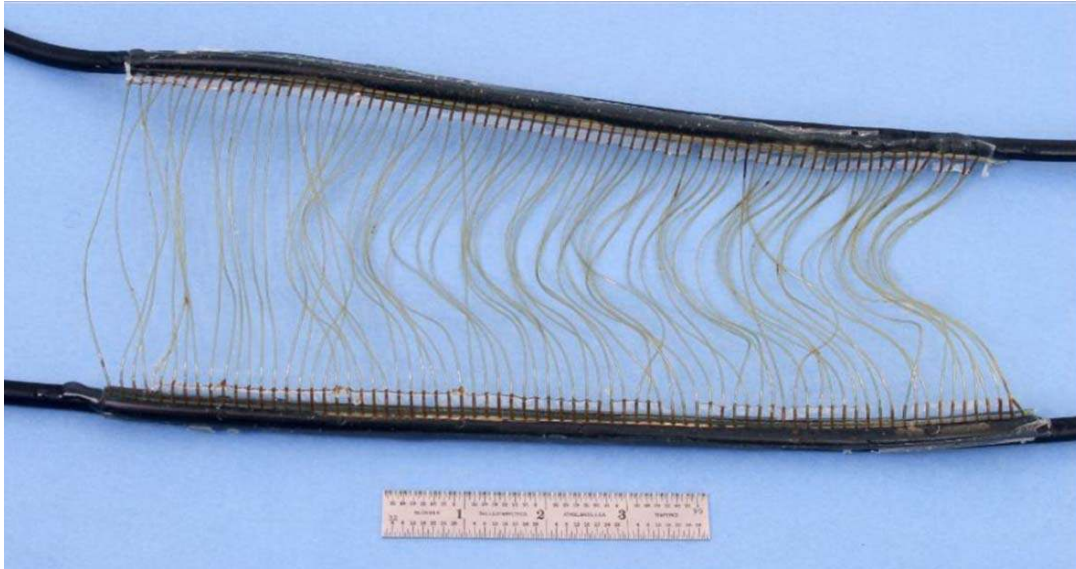

Figure 2. Proof-of-Concept, Flexible Latent Cooling Panel Demonstrated 45 W/ft² Capability. The photo shows one segment of the complete panel, which covered 1 ft².

II. The Need for Non-Venting Thermal and Humidity Control

Existing technology for thermal control inside space suit pressure garments was developed for short-duration missions in low earth orbit, in which water venting was acceptable and regular suit maintenance could be scheduled at relatively high frequency. In contrast, future exploration missions will need to minimize water venting and prevent phenomena—such as condensation of perspiration inside the pressure garment—that can effect hygiene and comfort and lead to more frequent maintenance.

The space station EMU cools the astronaut primarily by circulating cool water through the LCVG (Figure 3). As it flows through the LCVG, the circulating water absorbs sensible heat directly from the astronaut and possibly latent heat as well, if water vapor from the ventilation gas condenses on the cool water tubes. Warmed water then flows through the sublimator, transferring heat to water ice that gradually sublimates and vents to vacuum. The chilled circulating water is then pumped back to the LCVG. NASA plans to replace the sublimator with a Space Suit Water Membrane Evaporator (SWME) in future space suits. The SWME enables the circulating water to cool by evaporating directly to ambient vacuum as it flows through an array of porous, hydrophobic hollow fibers. The SWME reduces the temperature drop needed for ultimate heat rejection and solves many practical issues related to sublimator operation.

The EMU relies on venting water vapor for ultimate heat rejection, a trade-off that is favorable for current manned space flight. However, water venting can cost roughly 1 kg of water for every four hours of EVA activity, a loss rate that will not be sustainable on long-duration exploration missions. Furthermore, this method of cooling relies heavily on sensible cooling—that is, conduction of heat from the astronaut's body into the circulating water.



Figure 3. LCVG from the Extravehicular Mobility Unit (Jinny, does ILC have a better photo than this? –Mike) .⁸

⁸ <http://www.nasa.gov/audience/foreducators/space_suits/home/clickable_suit_nf.html>.

Maintaining sensible cooling as metabolic rates increase requires ever lower coolant and skin temperatures, with the difference between skin and coolant temperature increasing nonlinearly as indicated by typical thermal comfort curves (Figure 4). The sensible cooling approach is not always a good match for human metabolism, which evolved to control core temperature by latent cooling (i.e., perspiration). Figure 5, for example, shows NASA data for a typical crew member illustrating how sensible and latent cooling contribute to total metabolic heat during a 30-minute period of exercise followed by 60 minutes of recovery. Throughout the exercise and recovery periods, sensible heat rejection remains fairly constant while nearly all the additional metabolic load is removed via latent cooling.

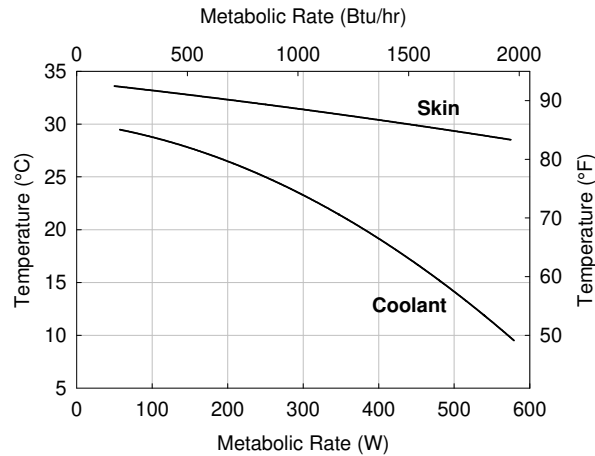

Figure 4. Thermal Comfort Cooling Curves (Ferl and Hewes 2008⁹).

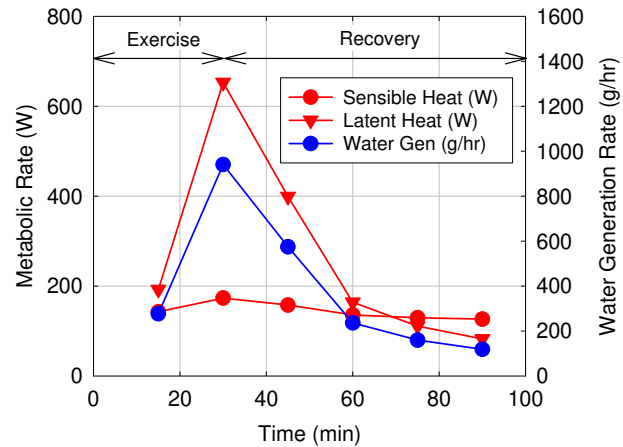

Figure 5. Crew Metabolic Heat and Water Generation Rates (NASA 2006¹⁰).

These data show that at high work rates the astronaut's metabolism will generate a large amount of water vapor. Figure 5 shows that the perspiration rate can approach 1000 g/hr during peak exercise. All this water vapor released inside the pressure garment will increase the partial pressure of water vapor and thus the dew point. At the same time the coolant temperature must decrease to absorb all the extra metabolic heat. The result is condensation of water vapor from the suit ventilation gas on the cool water tubes. While this process enables cooling, it also leaves excess liquid water inside the pressure garment. This water can absorb into the LCVG, make the astronaut over-cooled and uncomfortable after periods of high exertion, and can lead to unhygienic conditions after repeated use of the suit.

Perspiration that stays in vapor form in the ventilation gas will eventually flow through the CO₂ removal system, where it will be absorbed in the CO₂ removal beds. Future suits will use regenerable beds that periodically vent to space, so that this water will therefore be lost as well.

III. A Multipurpose Environmental Control System

This paper describes a hybrid cooling garment that combines all the existing capabilities of the LCVG with direct water vapor absorption through water-permeable membranes. As shown in Figure 1, the concept entails weaving an array of solid, water-permeable tubes into the LCVG fabric. Vapor manifolds couple all the tubes to an LCAR for water absorption and heat rejection. Our results show that a significant amount of latent heat rejection can be accomplished using relatively small lengths of tubing.

⁹ Ferl, J., Hewes, L., et al., "Trade Study of an Exploration Cooling Garment," 2008 International Conference on Environmental Control Systems, SAE Paper 2008-01-1994.

¹⁰ "Constellation Program Human-Systems Integration Requirements," NASA CxP 70024 Baseline, Release date Dec. 15, 2006.

System Operation. The schematic diagram in Figure 6 illustrates the water vapor transport path. Nafion tubes woven into the LCVG are coupled directly to the LCAR, which operates under partial vacuum with a very low water vapor pressure. Figure 7 plots the vapor pressure characteristic of the lithium chloride solution in the LCAR for the LiCl concentration (45%) that corresponds to the end of a mission (Conde-Petit 2009¹¹). At this concentration, and at a typical radiator temperature of 50°C, the vapor pressure in the LCAR is 1.8 kPa (13.5 torr). As shown in Figure 7, this vapor pressure is considerably lower than the maximum vapor pressure in the range of comfortable conditions defined in NASA CxP 70024, so that it is possible to exploit a vapor pressure difference of about 1 kPa (~7 torr) to drive water transport from the suit ventilation gas into the LCAR. Figure 8 illustrates schematically the water vapor pressures and temperatures in the three key volumes: the suit ventilation gas in the pressure garment, inside the Nafion tubes in the ECG, and in contact with LiCl/water solution inside the LCAR. Referring to Figure 6, the steps in water transport are:

1. Water vapor begins in the space suit ventilation gas. For astronaut comfort, the temperature will range from 20 to 25°C at 100% RH to 25 to 30°C at 10% RH, as illustrated in Figure 7.
2. Water vapor is absorbed into the outer surface of the Nafion tubes to maintain local equilibrium.
3. Water molecules diffuse through the Nafion tubes due to the concentration difference between the outer and inner surfaces.
4. Water molecules desorb from the inner surface of the Nafion tubes, also to maintain local equilibrium with the low water vapor pressure inside the tubes.
5. Water vapor in the tubes flows into the LCAR, then through an array of internal flow passages that bring it in contact with LiCl solution.
6. Water vapor in the LCAR is absorbed by the LiCl desiccant solution, which is contained in an array of porous sponges that are in good thermal contact with the radiating surface.
7. Heat generated by condensation and absorption of the water vapor conducts through the LCAR structure and radiates to space.

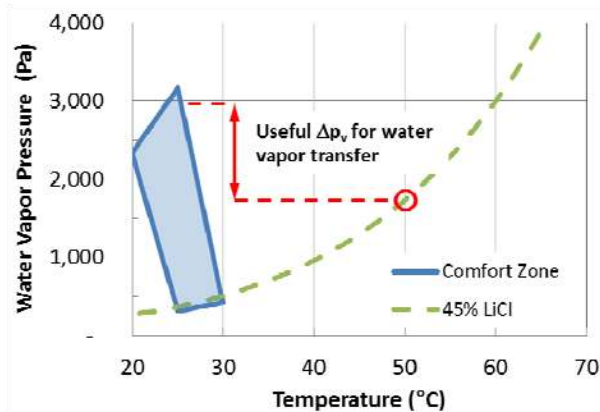

Figure 7. The LCAR Provides About 1 kPa of Water Vapor Pressure Difference.

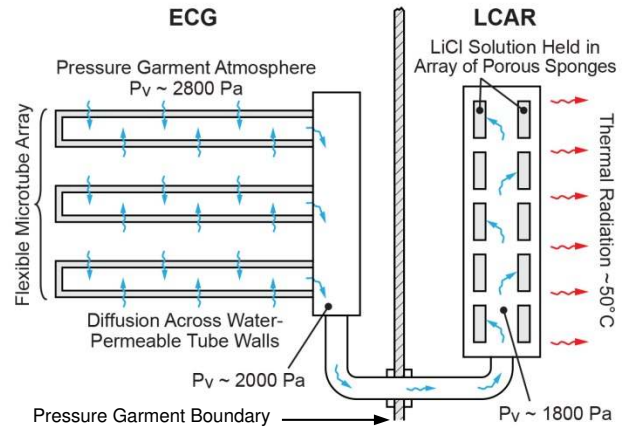

Figure 6. Water Vapor Transport in the ECG and LCAR.

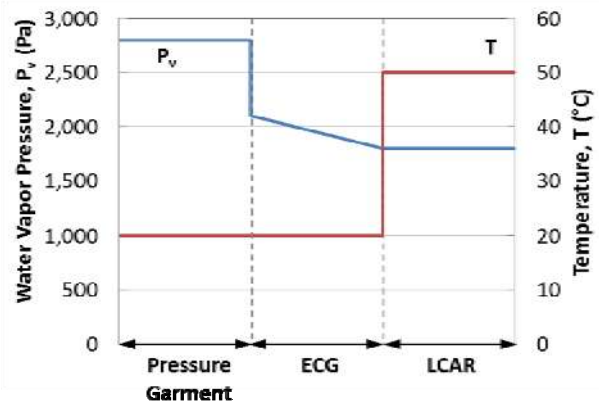

Figure 8. Typical Water Vapor Pressure and Temperature in the ECG and LCAR.

¹¹ Conde-Petit, M. R., "Aqueous Solutions of Lithium and Calcium Chlorides: Property Formulations for Use in Air Conditioning Equipment Design," Zurich, Switzerland, M. Conde Engineering, 2009.

Materials of Construction. Nafion tubing is available commercially from a number of vendors. We have had good experience with Nafion tubes produced by Perma Pure LLC, which are available with diameters ranging from 0.5 to 2.5 mm and wall thicknesses ranging from 75 to 300 μm .¹² Figure 9 is a photograph of a tube array we built using Nafion tubes purchased from Perma Pure to demonstrate the feasibility of building a water vapor exchanger (WVX) for future CO₂ removal subsystems. The purpose of the water vapor exchanger is to conserve water by preventing water vapor in spacecraft cabin air from reaching regenerable amine beds, where it would be absorbed and vented along with the CO₂ (contract NNX12CE88P).

The LCAR would be built using methods recently demonstrated by the authors. The LCAR is assembled from a graphite honeycomb structure that supports LiCl absorber sponges in a configuration that enables a compact heat/mass exchanger (Figure 10). Manifold elements are attached to both ends of the LCAR—one couples the LCAR interior to the Nafion tubes in the ECG and the other leads to a capillary vent to remove noncondensable gas.

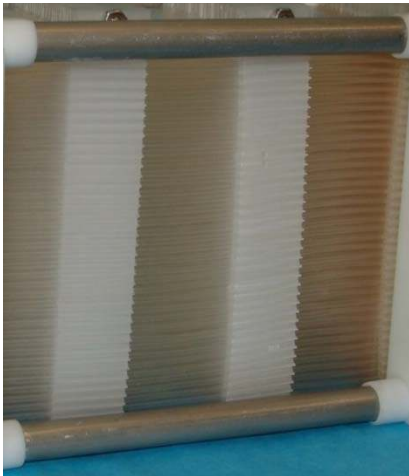

Figure 9. Typical 1 mm Nafion Microtubes Used to Build the Core of a Water Vapor Exchanger.

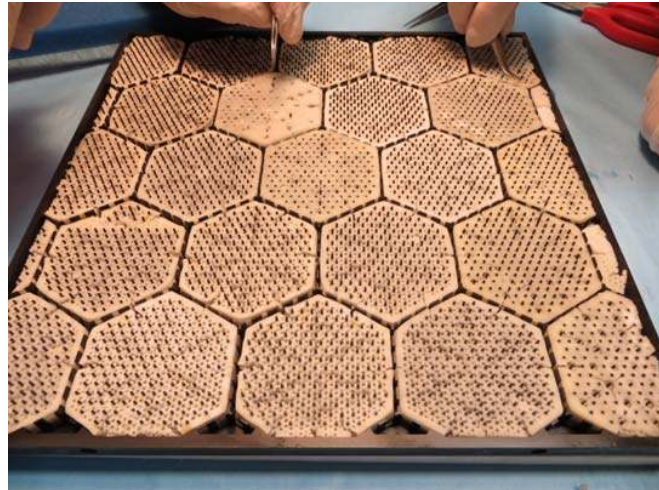

Figure 10. Partially Assembled, 1 ft² LCAR Panel Showing Honeycomb Structure and Sponges That Contain LiCl Solution.

IV. ECG Development and Demonstration

We have tested the feasibility of the ECG by demonstrating operation of a proof-of-concept ECG and developing a conceptual ECG design that integrates latent cooling tubes with an existing LCVG. We developed fabrication methods needed to produce flexible arrays of latent cooling tubes and manifolds, then built a proof-of-concept ECG by combining our latent cooling tubes with a sample LCVG swatch. We demonstrated 45 W/ft² latent cooling potential in a simulated space suit environment, and produced a conceptual design showing how the latent cooling tubes and manifolds can integrate with an LCVG. We also verified that oxygen losses due to diffusion across the Nafion membranes would be very small, and verified that Nafion is compatible with the requirements for use inside a space suit pressure garment.

A. Demonstration of Fabrication Methods

We developed new fabrication methods for producing flexible latent cooling panels comprised of Nafion tubes joined to flexible manifolds. Figure 11 shows the two types of latent cooling panel sections that we fabricated: (a) a dual-header section that uses 6-in. lengths of Nafion tube, and (b) a single-header section based on 3-in. lengths of Nafion tube. The Nafion tubes are bonded and sealed to secondary EPDM manifold tubes (0.25 in. OD).

The panels must be leak tight to prevent gas leakage from the pressure garment into the LCAR, and they must be stable against the suit internal pressure (4.2 psia) acting against the rough vacuum inside the tubes. We leak- and pressure-tested the final structures and found them to be leak tight and resistant to collapse under external pressures up to 14.7 psia.

¹² <<http://www.permapure.com/products/nafion-tubing/>>.

B. Proof-of-Concept ECG

We built a 1 ft² prototype ECG by assembling a latent cooling panel and combining it with a 1 ft² LCVG sample. Figure 12 shows the LCVG sample, which was combined with two single-header (3-in.) and one double-header (6 in.) latent cooling panels (Figure 11) to create the proof-of-concept ECG. A photograph of the assembled ECG in the test facility is shown later (Figure 16).



(a) Dual headers with 6-in. Nafion tubes

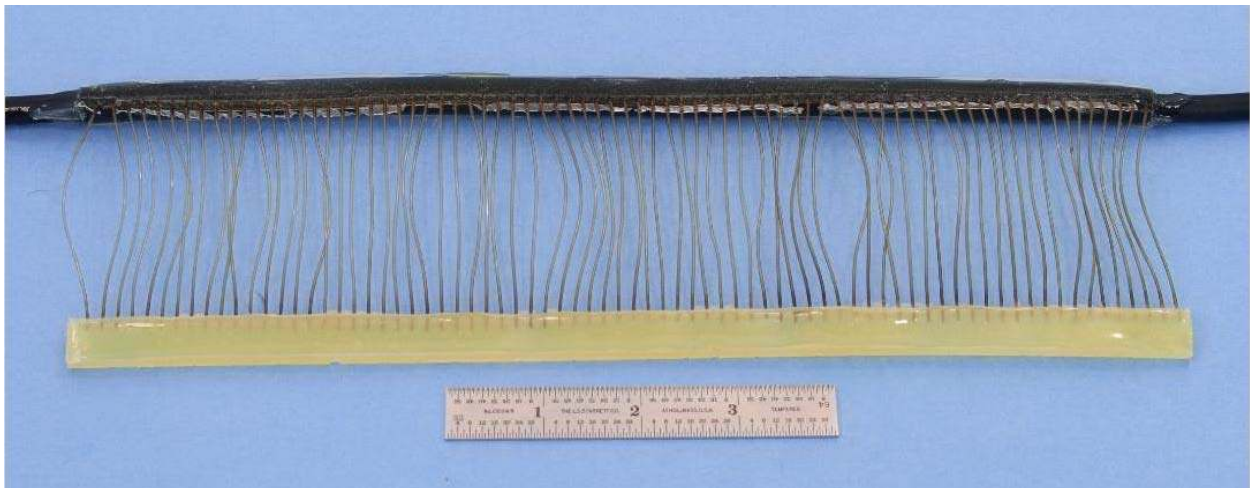

(b) Single header with 3-in. Nafion tubes

Figure 11. ECG Samples Produced in Phase I

C. Demonstration of Latent Cooling Performance

We demonstrated the latent cooling capability of the ECG by measuring its performance in an environment that simulated operation inside a space suit. Results from these tests show that the latent cooling panels have the potential to absorb 45 W/ft² of latent heat while operating in conjunction with the LCVG.



Figure 12. LCVG Sample Swatch (1 ft²)

Figure 13 and Figure 14 show the test facility, which comprises a low-pressure chamber roughly 18 in. in diameter that accommodates a 1 ft² sweating hot plate that simulates the skin of a crew member inside a space suit. The sweating hot plate is built from a heated copper plate bonded to a 1 ft² patch of Membrana Liqui-Cel hollow fiber membrane (Figure 14b). The hollow fiber membrane is an array of hydrophobic, porous microtubes sewn together to create a flexible array. This is essentially the same hollow fiber membrane used in NASA's SWME. By adding heat to the copper plate to maintain the desired test temperature and forcing water to flow through the hollow fibers, we create a source of sensible and latent heat that simulates perspiration from a crew member's skin. In the test facility, we provide water at a controlled temperature from a circulating loop while monitoring the water inventory in a graduated cylinder. The change in water inventory lets us calculate the rate of latent heat transfer from the sweating hot plate. The difference between the calculated latent heat and the total amount of heat supplied to the copper plate is the amount of sensible heat generated by the system.

The ECG comprises three layers: Nearest the simulated skin is a thin layer of material that simulates the comfort garment worn by crew members. Next is the latent cooling panel, followed by the liquid-cooled LCG. The latent cooling panel is connected to a condenser that simulates the LCAR in a complete system. The condenser is cooled by a second loop of temperature-controlled circulating water, and the LCVG tube is supplied with a forced flow of circulating water from a third laboratory chiller.

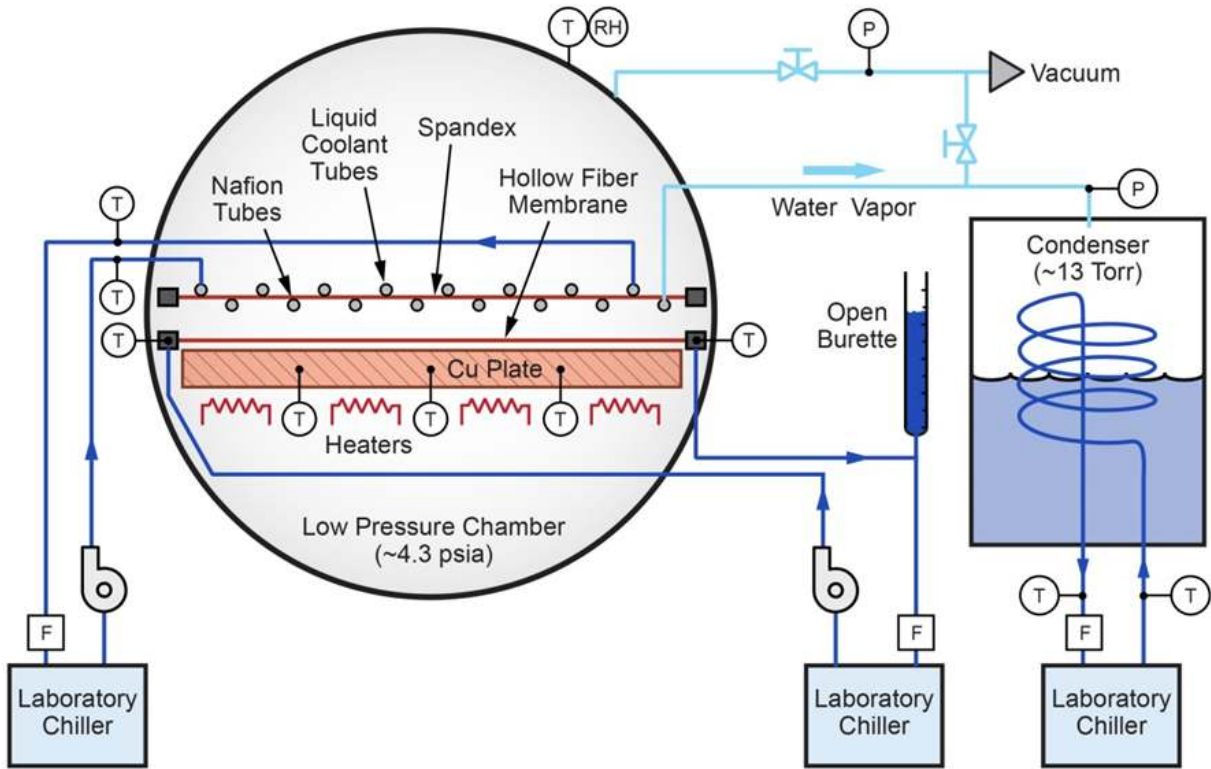
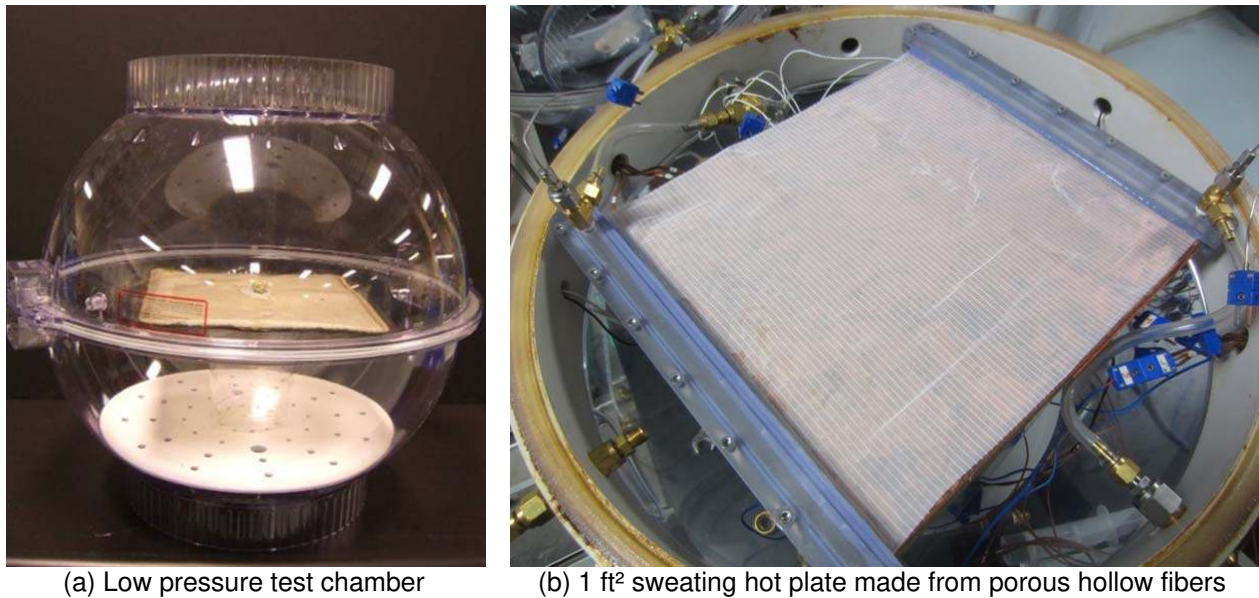

Figure 13. Test Facility for Demonstrating Operation of the Proof-of-Concept ECG



(a) Low pressure test chamber

(b) 1 ft² sweating hot plate made from porous hollow fibers

Figure 14. Low-Pressure Facility for Sweating Hot Plate Tests

Key measurements from this test include:

1. Flow rate and temperature change of the condenser cooling water. The amount of heat picked up by the cooling water in the condenser is equal to the latent cooling provided by the latent cooling panel.

2. Flow rate and temperature change of the LCVG cooling water, which allows us to calculate the sensible cooling provided by the LCVG.
3. Temperature of the sweating hot plate. We control this temperature at 33°C during testing to simulate skin temperatures during exercise.
4. Water evaporation from circulating loop that feeds the hollow fibers on the sweating hot plate, which provides a redundant measurement of latent heat transfer.
5. Total heat input to the sweating hot plate, which provides a redundant measurement of total heat transfer.

Figure 15 illustrates assembly of the proof-of-concept ECG in the test chamber. First the comfort layer is placed on top of the simulated skin surface (a), followed by the latent cooling panels (b), and then the LCVG (c). The entire assembly is pressed into contact by placing a plexiglas panel and some light weights (roughly 1 kg) on top of the LCVG.

Tests demonstrate that the ECG provides both latent and sensible cooling in amounts that are appropriate for space suit cooling. Figure 16 shows data from tests of the latent cooling panel alone. Figure 16a shows the “skin” temperature, which was held steady at 33°C throughout the test, and the temperatures of the condenser coolant. Note that the condenser temperatures are low in order to generate a vapor pressure that simulates the LiCl/water solution in an LCAR; the condenser coolant is never physically in contact with the latent cooling tubes. Figure 16b plots the heater input power (held steady at 47 W during this test) and the latent cooling provided by the Nafion tubes. We calculated the latent cooling by calorimetry using the condenser coolant flow rate and temperature rise. The latent cooling in this test varied from 40 to 44 W, in good agreement with the amount of heat provided to the skin.

Figure 17 plots data from a test of a proof-of-concept ECG, comprising our latent cooling panel plus the LCVG sample. This test demonstrated that the latent cooling tubes continue to absorb a significant amount of water vapor despite the presence of (potentially) very cool water in the LCG tubes. Figure 17a shows the key temperatures during this test. During the first portion of the test (70 to 90 min), the LCG inlet temperature was maintained at 23°C. During the second portion (110 to 130 min), the LCG inlet temperature was held at 12°C. Figure 17b shows the measured cooling during these tests. After correcting for calculated heat leaks, we found that the LCG absorbed 15 and 37 W for inlet temperatures of 23 and 12°C, respectively. The latent cooling panel absorbed 47 W worth of latent heat for the warmer LCG case and 43 W during the cooler LCG case. These results show a small reduction in latent cooling for very cool LCG water, which is expected since condensation on the cold LCG tubes will compete with the Nafion for water vapor. Nevertheless the latent cooling was fairly constant across this relatively wide range of LCG inlet temperatures.



(a) Comfort Garment



(b) Latent Cooling Tubes

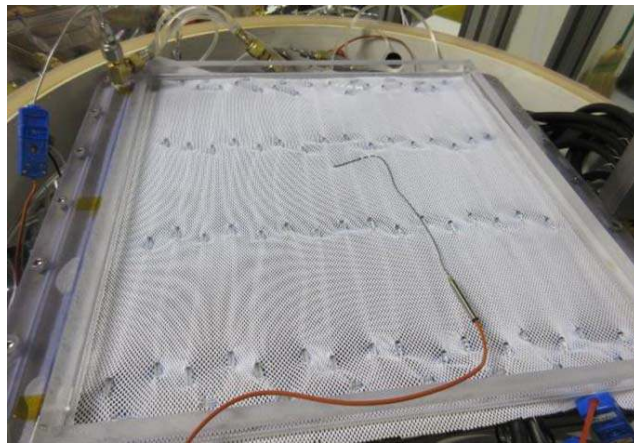

(c) LCVG

Figure 15. Assembly of ECG on the Sweating Hot Plate

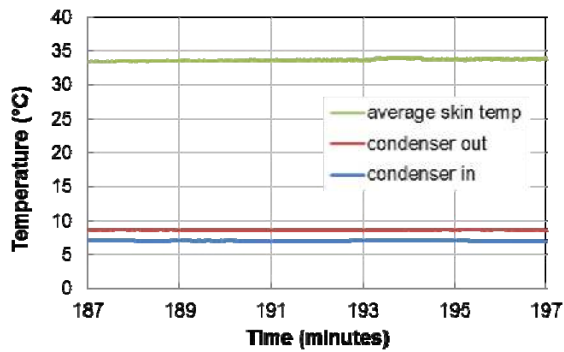

(a) Temperatures at skin surface and in condenser

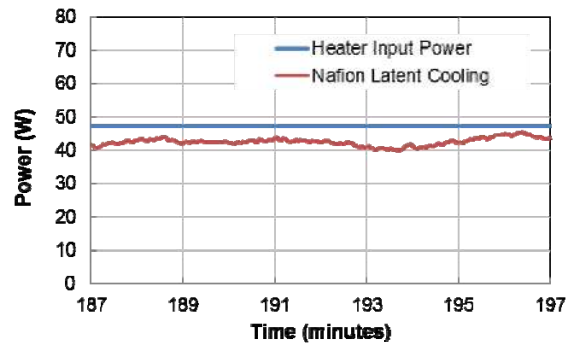

(b) Heater input and latent cooling power

Figure 16. Latent Cooling Performance without LCVG Cooling

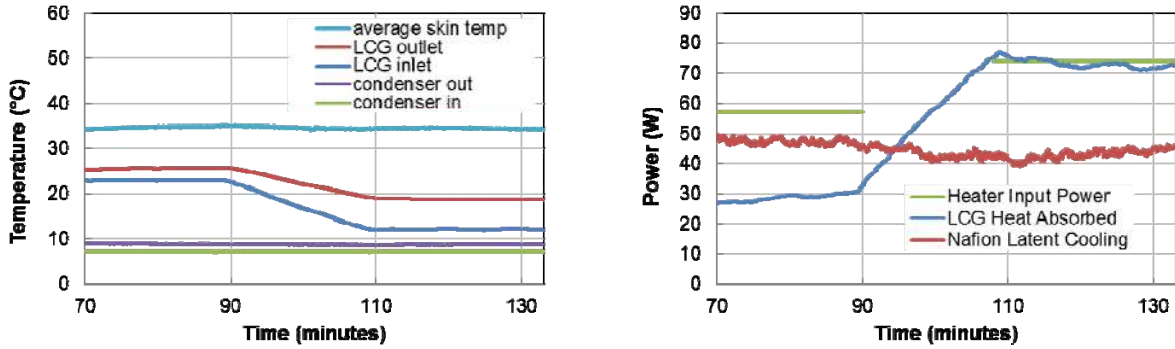

(a) Measured temperatures

(b) Measured latent and sensible heat absorption

Figure 17. Latent and Sensible Cooling (Latent Cooling Tubes + LCVG)

These results agree well with predictions of our design model. We predicted the water vapor absorption capability of the Nafion tube array by scaling from earlier tests of Creare's Environmental Control and Dehumidification Garment (ECDG). This scaling should be valid since the ECDG is made from the same material (Nafion) and was tested under the same basic conditions as the Nafion tube array. Our scaling analysis predicts that the tube array should absorb 50 W/ft² of latent heat, compared with the measured range of 43 to 47 W/ft², which is 6 to 14% lower depending on test conditions. It is not surprising that the Nafion tubes perform slightly less well than the ECDG, which was a flat sheet of Nafion. All the differences between the ECDG and tube array tests would contribute to a lower rate of water absorption in the tubes:

1. The comfort garment used in Phase I introduces a new mass transfer resistance that was not present in the ECDG tests.
2. Not all the Nafion tube area is equally effective. Water absorbed on the far side of the tube has a greater diffusion resistance to mass transfer than water vapor absorbed on the near side.
3. The cold LCG tubes compete for water in the Phase I tests. These were not present when testing the ECDG.
4. There are various minor losses that subtract from the available area for mass transfer, including the space taken up by the manifold tubes and reductions in Nafion surface area due to fabrication defects.

D. Design of an Environmental Control Garment

We developed a concept design for an ECG that integrates latent cooling panels with an existing LCVG. We specified the number and length of Nafion tubes and manifold tubes based on an analysis of vapor flow in the structure. We then identified the most promising locations for these panels based on perspiration rates and proximity of ventilation tubing. Whenever possible the vapor manifold tubes were aligned with the existing ventilation tubes to minimize the impact on crew comfort.

The total number, length, and diameter of Nafion and manifold tubes is selected to enable 200 W of latent cooling while meeting the limits on pressure drop determined by the allowable, comfortable water pressure in the suit and the vapor pressure in the LCAR at the end of a mission. As discussed in Section III and illustrated in Figure 7, the overall pressure drop is limited to less than 1 kPa (about 7.5 torr). There are two primary mechanisms that contribute to the overall pressure drop:

1. Diffusion of water molecules through the Nafion tube walls. The drop in water vapor pressure due to diffusion depends on the flow rate of water vapor, tube surface area, tube wall thickness, and the diffusion coefficient for water in Nafion.
2. Pressure losses due to vapor flow through the Nafion tubes. The pressure loss depends on the number of tubes in parallel, total flow area, tube inner diameter, flow length, and water vapor properties.
3. We estimated the pressure drop from diffusion by scaling from our prior work developing a Nafion-based evaporation cooling and dehumidification garment (ECDG). Pressure drops due to vapor flow through Nafion tubes can be calculated using standard relationships for laminar flow through tubes. Table 1 lists parameters for our nominal design, based on 100 W of total latent cooling and use of COTS Nafion tubes (Perma Pure TT-030). Sensitivity to the number and inner diameter of the tubes is plotted in Figure 18.

Figure 19 illustrates the layout of a 1 ft² Nafion panel based on the TT-030 tubes and design to provide 50 W of latent cooling. The basic design is a tree-type network of small-diameter Nafion tubes that feed vapor to a branching structure comprising a primary and several secondary manifolds. The manifold diameter increases as the

water vapor flow rate from multiple tubes accumulates. The size of the manifold tubing is selected to meet overall pressure drop targets.

Table 1. Design Parameters for Basic Latent Cooling Panel	
Latent cooling (W)	100
Material	Perma Pure Nafion TT-030
Tube OD (mm)	0.84
Wall thickness (μm)	102
Overall tube length (m)	46
Number of tubes	600
Tube length (cm)	7.7
Tube pressure drop (torr)	3.0
Total tube mass (g)	25
Covered area (ft^2)	2.0
Tube pitch (mm)	4.0

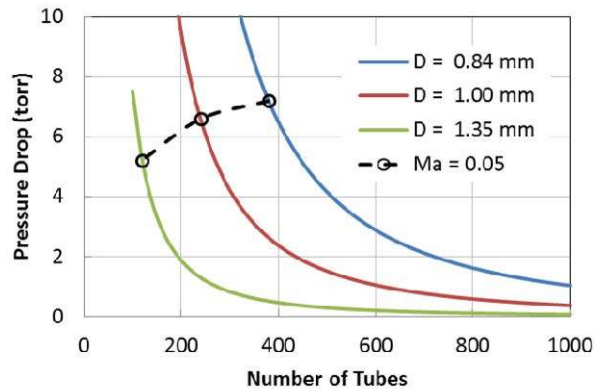

Figure 18. Calculated Pressure Drop for Water Vapor Flow through Tubes (100 W latent cooling).

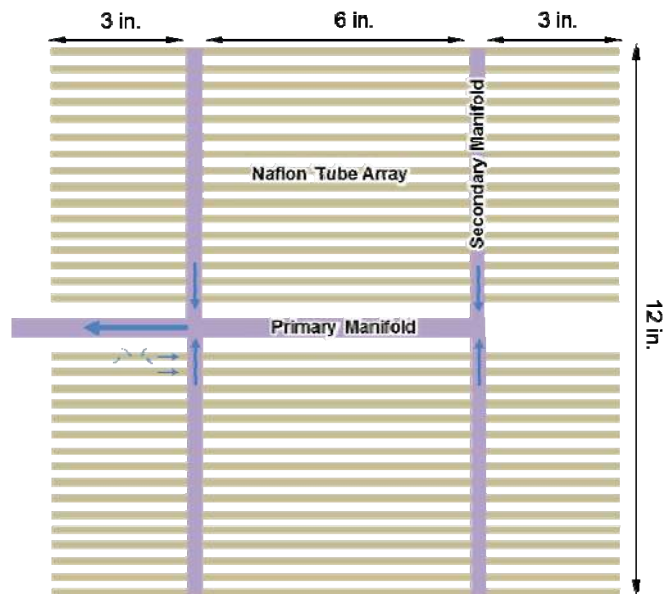

Figure 19. Basic Latent Cooling Panel Design for 50 W Latent Cooling

We used this basic cooling panel design to identify panel locations and layouts (including variations of the basic design that preserved overall pressure drop) that would (a) concentrate the Nafion tubes in locations that produced the most perspiration, and (b) would align well with the existing LCVG for minimal impact on garment comfort. Figure 20 shows the resulting panel layout. The design calls for latent cooling panels in three locations: upper arm, upper thigh, and torso. The layout satisfies two key requirements for minimizing impact on garment comfort. First, the panels must not interfere with the overall stretchability of the LCVG fabric. To meet this goal, the water absorption panels are limited to a number of discrete patches that will be flexible but not stretchable. Enough stretchable fabric must be left between the cooling patches for good garment fit and comfort. Second, the diameters

of the primary manifold tubes were large enough that they should be routed whenever possible with the existing ventilation lines.

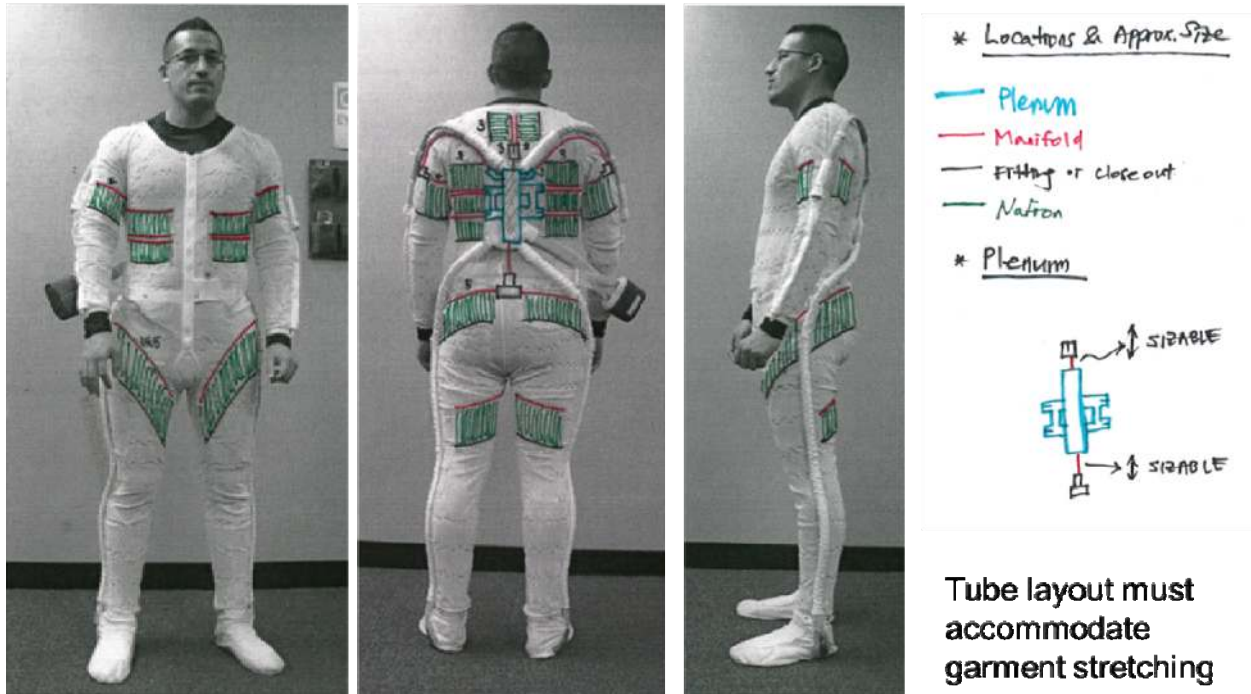

Figure 20. Panel Layout Design for Maximum Water Vapor Absorption and Minimum Impact on Mobility

Based on this overall layout, we then produced detailed designs for the three types of latent cooling panels, illustrated in Figure 21 and Figure 22. Total tube length in this design is 88.6 m (291 feet), which exceeds the nominal length in Table 1 by nearly a factor of two, and should provide nearly 200 W of latent cooling.

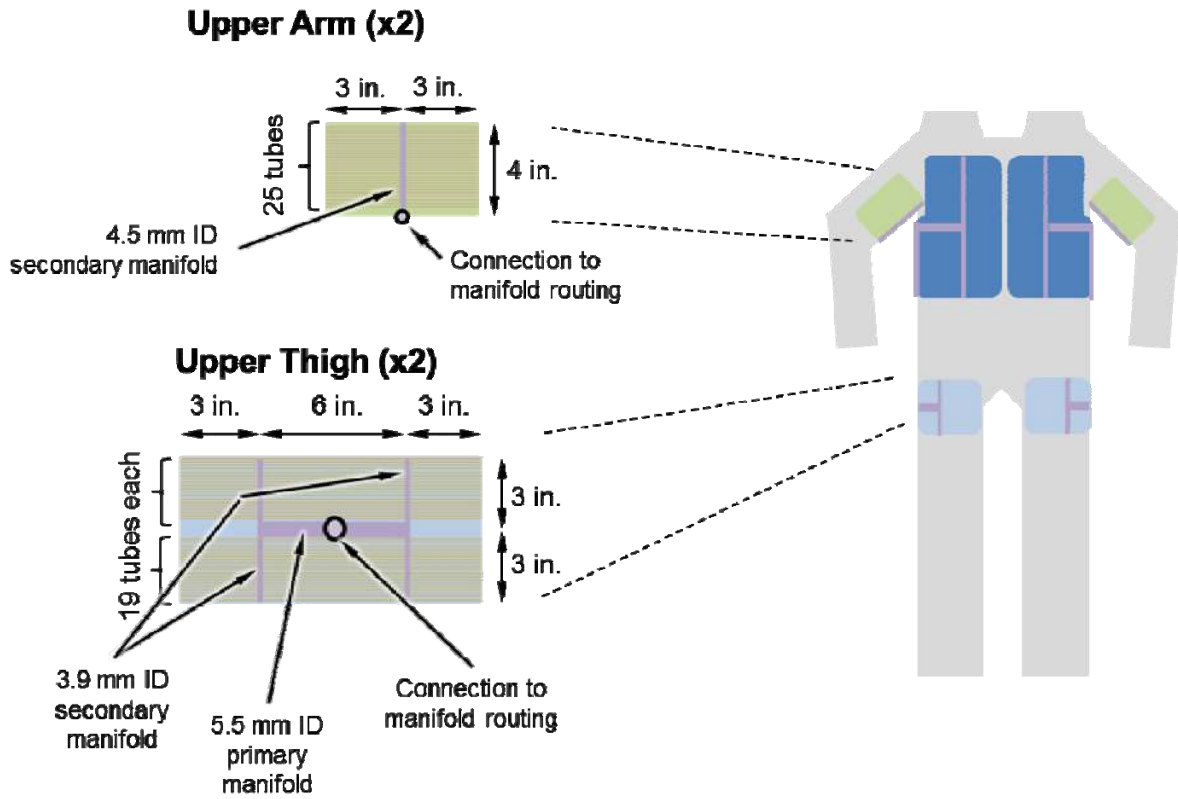

Figure 21. Detailed Specifications for Latent Cooling Panels: Upper Arm and Upper Thigh

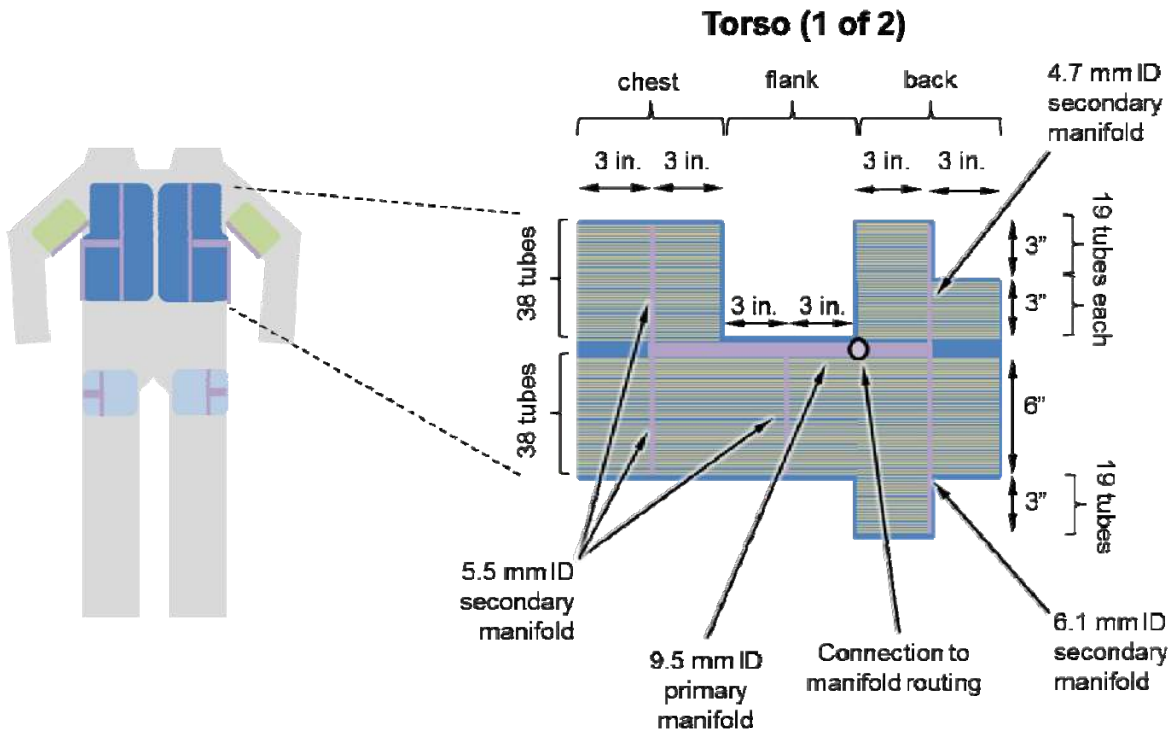

Figure 22. Detailed Specifications for Latent Cooling Panels: Torso

E. Nafion Compatibility with Operation in a Space Suit

We have researched the compatibility of Nafion with requirements for operation inside a space suit and confirmed that Nafion is suitable for use inside a space suit pressure garment (Jinny, anything additional we can add here? -Mike). We also reviewed the available data for oxygen diffusion through Nafion and found that oxygen loss through the ECG membranes will be negligible. Manufacturer's data show that the permeability of oxygen in Nafion is about 1.5 barrers. Permeability in barrers has units of (m³-m)/(m²-s-Pa), and is calculated from:

$$\text{Permeability in barrers} = \frac{(\text{volume of gas @STP})/(\text{thickness of membrane})}{(\text{surface area of membrane})(\text{time})(\text{pressure difference})} \quad (1)$$

When applied to our nominal ECG design (0.464 m² of Nafion at a thickness of 102 μm with a pressure difference of 4.2 psia), we compute a leak rate of oxygen through Nafion of 1.52 × 10⁻⁹ std m³/s. This is over three orders of magnitude smaller than the permissible rate of oxygen leakage from the space suit (2.28 × 10⁻⁶ std m³/s), so we conclude that the oxygen leak rate through Nafion is negligible.

V. Conclusions

The results described in this paper support the feasibility of the proposed environmental control garment. The project successfully addressed all the questions raised in the technical objectives regarding design requirements, ECG performance, and ability to meet critical design requirements.

Design Requirements for the ECG. We identified the thermal, fluid, and ergonomic factors that must be considered for the hybrid garment design. We worked closely with ILC Dover to formulate a design concept that integrates well with the existing LCVG with minimal potential to impact crew comfort.

ECG Performance. Phase I tests demonstrated that the proof-of-concept panels can absorb roughly 45 W/ft² of latent heat over a wide range of LCG operating parameters. This level of water vapor absorption agrees well with our design models.

Prototype Design and Design Requirements. Scaling from the Phase I test results, the 3.83 ft² prototype ECG proposed in Phase I should provide 173 W of latent cooling. The key material (Nafion) meets requirements for operation inside a space suit pressure garment. We formulated plan that would allow the cooling garment to include latent cooling tube sections while still meeting stretch requirements for fit. Vapor manifolds in the design were aligned with existing ventilation tubes to minimize effects on crew comfort.

Acknowledgments

The authors gratefully acknowledge the support of the Crew and Thermal Systems Division at NASA Lyndon B. Johnson Space Center and the NASA SBIR program.

References