

Multihop Relay Extension for WiMAX Networks — Overview and Benefits of IEEE 802.16j Standard

● Masato Okuda ● Chenxi Zhu ● Dorin Viorel

(Manuscript received January 16, 2008)

In 2006, the IEEE 802.16 Working Group (WG) approved a Project Authorization Request (PAR) focused on the Relay Task Group (TG). The main task of this Relay TG was to develop an amendment to the IEEE Std. 802.16 enabling the operation of relay stations (RSs) in OFDMA wireless networks defined by 802.16. In September 2007, the Relay TG completed the first phase of its work, getting the WG's approval for the first draft. The final approval of this amendment is expected to take place during the second half of 2008.

This paper presents the theoretical benefits and performance evaluation of relaying technology used in WiMAX wireless systems, providing insight into the rationale behind the main features adopted by the Relay TG. We describe how four different types of RSs can be implemented using different feature sets, each one optimized for a different deployment scenario. Based on the theoretical benefits and performance evaluation results, we focus on the RS type showing the most promising performance, which is the non-transparent RS operating in distributed scheduling and security mode, and outline its operation.

1. Introduction

The first functional WiMAX wireless air interface was defined by the IEEE 802.16-2004 released in 2004, targeting fixed wireless broadband access systems.¹⁾ An amendment (802.16e) was introduced in 2005, enhancing the specification, to support mobile features using OFDMA.^{1),2)} The main target of the 802.16 standards is to provide a comprehensive set of specifications of the air interface, while the WiMAX Forum defines the system profile, which is a list of selected functionalities for a particular usage scenario, and overall wireless network architectures.³⁾

It is expected that WiMAX operators will need to increase the density of base stations in order to properly address the challenges posed by the mobile Non-Line-of-Site propagation channels.⁴⁾ Therefore, in order to enable rapid and cost-effective deployment of WiMAX

networks, relay technology, which requires no backhaul line, is considered to be a key feature for successful business.⁵⁾ Then, a new Project Authorization Request (PAR), defining an amendment to the 802.16 standard, named 802.16j, specifying the relay station (RS) and multihop relay base station (MR-BS), was approved in 2006.⁶⁾

The 802.16j standard defines an air interface between an MR-BS and an RS with the following minimal functionality:

- Perfect transparency for a mobile station (MS) referenced to the network (no changes allowed to the legacy MS).
- The RS devices are expected to support all the licensed bands allocated for systems based on 802.16e.
- The RS shall support a point-to-multipoint network topology (and not a mesh one).

This paper details the RS concept as described by the IEEE 802.16j standard (Draft 4), introducing the four types of RSs, from the perspectives of physical layer (PHY) and media access control layer (MAC).⁷⁾ A comparison between the RS types is also provided based on theoretical benefits and the results of the network performance simulations for different RS types. Based on this comparison, we will focus on the non-transparent RS operating in distributed scheduling and security mode. Then, the details of the PHY and MAC features and operation of this high performance RS type will be introduced, followed by a summary.

2. RS types and usage Model/Performance

2.1 RS categories

RSs are classified into four types according to PHY processing, scheduling and security mode.

From a PHY processing perspective, an RS has two modes, transparent (T-RS) and non-transparent (NT-RS):

- A T-RS doesn't transmit a preamble and it doesn't broadcast control messages such as DL-MAP. An MS physically connected to a T-RS receives broadcast signals directly from the MR-BS and is not aware of the existence of the RS (no "logical" connection). A T-RS relays only data traffic.
- An NT-RS operates as a BS for a connected MS. The NT-RS transmits a preamble and other broadcast messages and relays data traffic as well. An MS is physically and logically connected to an NT-RS.

An example is provided in **Figure 1**.

The radio link between an MR-BS or RS and an MS is called an access link, while the link between an MR-BS and an RS or between a pair of RSs is called a relay link.

From an MAC perspective, each RS can be also characterized by scheduling and/or security capabilities:

- An RS that could have the capability of

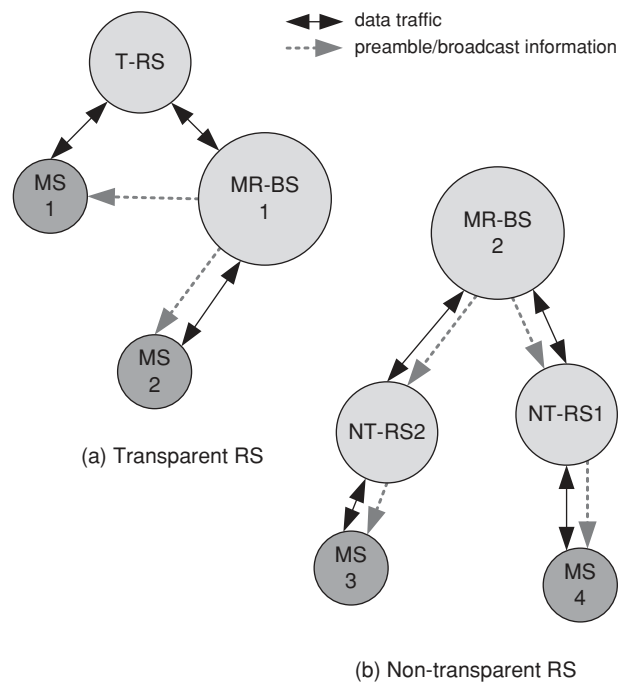

Figure 1 Example of a possible cell topology involving relay stations.

scheduling and/or security operates in distributed mode, but otherwise it operates in centralized mode. An RS operating in distributed scheduling mode creates DL-/UL-MAPs to allocate bandwidth to its subordinate MSs. The distributed scheduling mode may operate with either (centralized or distributed) security mode. The centralized scheduling mode is usually coupled with the centralized security mode.

- An RS in centralized scheduling doesn't have scheduling and security capabilities. A centralized mode allocates bandwidth to its subordinate MSs based on MAPs created by the MR-BS.

Table 1 shows the comparison results between four types of RSs characterized by the three factors mentioned above.

A T-RS can operate in centralized scheduling and security mode only, since it doesn't generate DL-MAP. On the other hand, an NT-RS can operate in either scheduling mode, while the

Table 1
Comparison of four RS types.

PHY processing	T-RS	NT-RS		
Scheduling mode	Centralized	Centralized	Distributed	
Security mode	Centralized	Centralized	Centralized	Distributed
Throughput Improvement	✓	✓	✓	✓
Coverage extension		✓	✓	✓
Signaling overhead/latency			✓	✓
Higher BW efficiency				✓

distributed security mode operates in the distributed scheduling mode only.

1) Throughput improvement

All types of RS can improve the Carrier to Interference and Noise Ratio (CINR) of the access link for the MS.

2) Coverage Extension

The cell coverage is limited by the preamble and broadcast message coverage.

A T-RS doesn't send those signals, so only NT-RS can expand service coverage.

3) Signaling overhead/latency

In the centralized scheduling mode, all information of an RSs access link connected to its MSs, such as channel measurement and bandwidth requests, are forwarded to the MR-BS, in order for the MR-BS to generate the DL-/UL-MAPs on behalf of the RS. On the other hand, an RS in distributed scheduling mode can deal with that information by itself.

4) Higher bandwidth efficiency

When relaying MAC packets, it will be necessary to change packet size by fragmentation and/or packing at an RS to make full and efficient use of the available bandwidth resource. Only the distributed security mode maximizes bandwidth efficiency by optimizing packet size since an RS shall decrypt encrypted packets before fragmentation/packing.

Taking account of the salient features of each RS type, we categorize typical usage scenarios below in terms of PHY processing and scheduling mode.

1) T-RS

This type of RS is used for a limited intra-cell throughput improvement but not for coverage extension, for low-cost implementations. In particular, it is also possible to use transparent relaying for uplink only in order to improve the uplink budget and save on MS power consumption. T-RS will not provide full support for MS mobility applications but it could remain a cost-effective solution for fixed and nomadic applications.

2) NT-RS in centralized scheduling mode

This type of RS provides throughput improvement and coverage extension especially in a low-MS-mobility environment, such as inside a building, because of its latency issue. Although this type of RS could be a more cost-effective RS implementation compared with the distributed scheduling mode, the maximum number of RSs in the MR-BS cell is limited by the MR-BS capability and by the related signaling overhead, as well as by the increased complexity of the MR-BS scheduler.

3) NT-RS in distributed scheduling mode

This type of RS can be used for both throughput improvement and coverage extension in various environments. A distributed security model can achieve better bandwidth efficiency compared with a centralized one by allowing the RS more flexibility to fragment or concatenate MAC packets. This mode provides full support for MS mobility applications.

2.2 Performance evaluation

We evaluated the performance of a conven-

Table 2
System parameters.

System parameter	Value
Number of cells	19
Operating frequency	2500 MHz
TDD frame length/number of DL data symbols	5 ms/47 symbols per frame
Channel bandwidth	10 MHz
BS-to-BS distance	1 km
RS-to-BS distance	375 m
Number of sectors per cell	3
Frequency reuse plan (BS)	1/3/3 ¹
Number of RSs per sector	3
BS Tx power/antenna gain	43 dBm/16 dBi
RS Tx power/antenna gain	37 dBm/10 dBi
MS Rx antenna/gain	Omni/-1 dBi
Relay (BS—RS) channel model (path loss model/multi-path channel model/shadowing)	Type D LOS/SUI-2/3.4 dB
Access (BS/RS—MS) channel model (path loss model/multi-path channel model/shadowing)	Type B NLOS/ITU-VA (30 km/hr)/8 dB

¹ Frequency reuse pattern is denoted as $c/n/s$, where c is the number of BS sites per cluster, n is the number of unique frequency channels required for reuse, and s is the number of sectors per BS site.

tional BS-only system, a T-RS and an NT-RS using distributed scheduling mode in the downlink (DL) direction by system level simulation. The set of the simulations follows the methodologies specified by the WiMAX Forum and the relay TG.^{8),9)} A typical 19 hexagonal cell cluster honeycomb model is used. Each cell is partitioned into three sectors. Nine stationary RSs are evenly deployed around the MR-BS, with three RSs in each sector. System parameters used in the simulation are given in **Table 2**. More details of simulation parameters and performance evaluation can be found in Reference 7).

A T-RS simply shares the same frequency segment as its super-ordinate MR-BS, so no additional frequency planning is required. In an NT-RS system, the NT-RS has to use a different segment than its super-ordinate MR-BS. **Figure 2** shows the frequency assignment for an NT-RS system. Each color represents a different frequency segment. A circular shape represents an RS employing an omni-directional antenna.

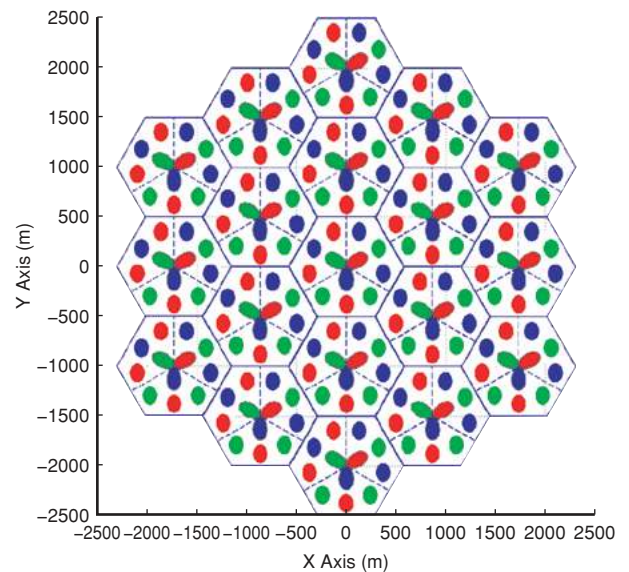

Figure 2
Frequency reuse pattern in non-transparent relay system.

An oval shape represents the sectorized antenna of an MR-BS.

Figure 3 shows the CINR distribution of the access DL in each system.

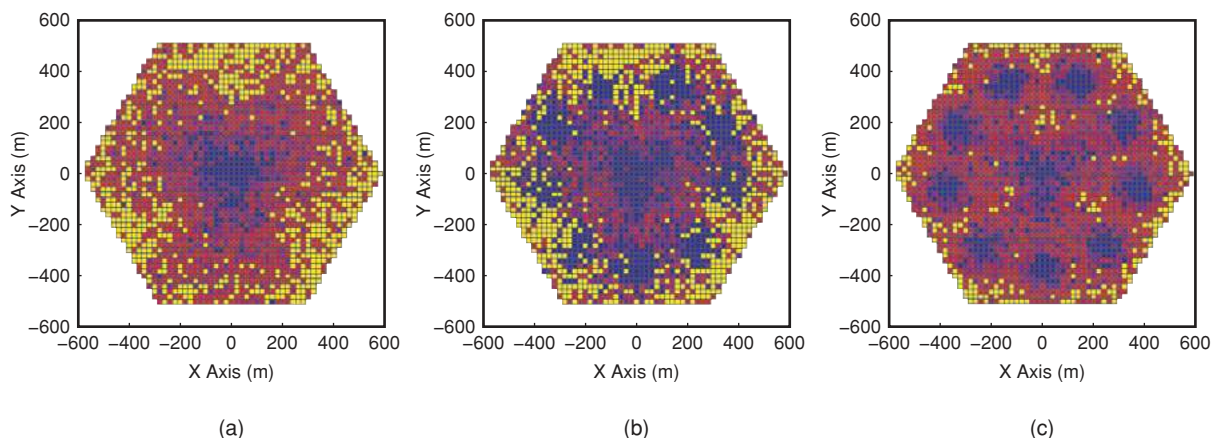

Figure 3
 CINR distribution of DL access link in 3 different systems. BS-only (a); 3 transparent RSs in each sector of MR-BS (b); 3 non-transparent RSs in each sector of MR-BS (c). Yellow represents area with no service, red represents area with QPSK 1/2 with repetition 4, blue represents area with 64 QAM 3/4, and various degrees of red and purple represent coverage area between QPSK 1/2 with repetition 4 and 64 QAM 3/4.

The coverage of the network is measured by the area in a cell where the signal quality received by the MS meets the threshold for the most robust Modulation and Coding Scheme (MCS) used. We assume a MR-BS or RS uses QPSK 1/2 with repetition rate of four to reach the MS with the lowest channel quality. The T-RS has the same coverage as the BS-only case, since the preamble and broadcast messages are transmitted by the MR-BS and determine the network coverage. The NT-RS improves the cell coverage (red and blue areas) from 75.7% (BS only and T-RS) to 89.1%.

Table 3 shows the aggregate cell capacity of each system estimated based on the DL CINR distribution. The ratios between the access zone and relay zone are adjusted individually for each RS type to maximize the cell capacity.

As shown in the table, both a T-RS and an NT-RS improve cell capacity. The NT-RS, especially, achieves largest capacity because of aggressive frequency reuse, despite relay link overhead.

The same system parameters are used in simulations to compare the basic performance of each system. However, improvement by RSs is not limited to the results shown here. It would

Table 3
 Aggregate cell capacity.

	BS only	T-RS	NT-RS
Access zone: Relay zone	n/a	3:2	3:7
Aggregate cell capacity (Mb/s)	6.2	7.7	8.8

be possible to derive further advantages from an RS by choosing appropriate configuration parameters for each system.

3. Non-transparent RS in distributed scheduling and security mode

As described in section 2, the NT-RS operating in distributed scheduling and security mode can achieve better performance than other RSs. Thus it can be widely used and most likely will be used in various environments. This section describes the details of the PHY and MAC features of the NT-RS in distributed scheduling and security mode.

3.1 Physical layer details

The 802.16j physical layer is based on the 802.16e PHY layer and it is fully backwards compatible.

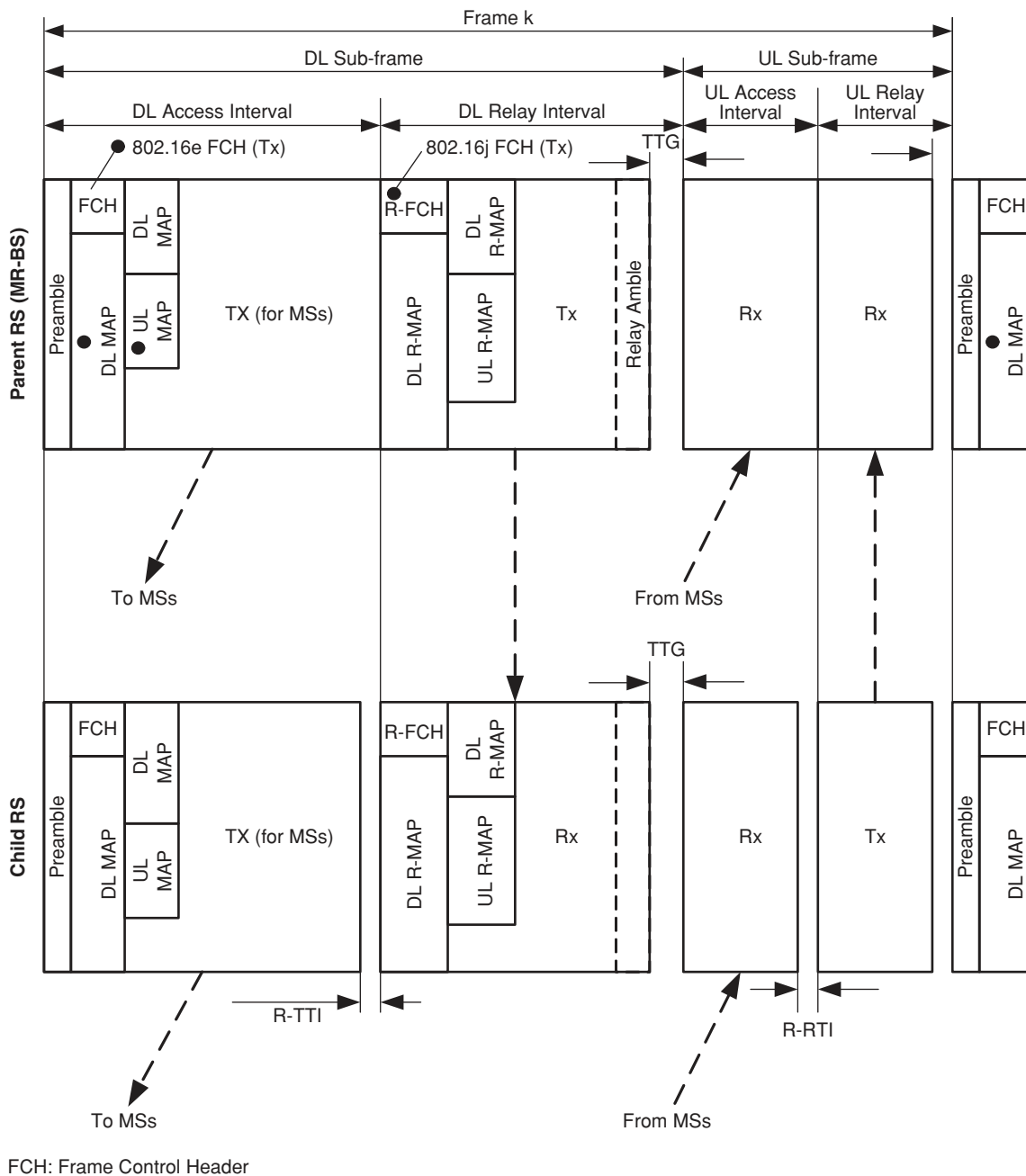

Figure 4
Basic non-transparent frame structure (for a two hop example).

A simplified 802.16j frame structure for NT-RS in a two-hop system is presented in **Figure 4**.

Each DL and UL sub-frame is split into one or more Access zones and Relay zones.

The DL/UL Access zones are dedicated for transmission between MSs and their access

stations (MR-BS or NR-RS), and they are fully compatible with the 802.16e frame structure, being mandatory zones. The access broadcast information, i.e. MAPs for the access link, is positioned in the same way as the 802.16e case (the next symbols following the preamble of the Access Intervals).

The DL/UL Relay zones following the access zones support the traffic between the MR-BS and the RS, thus being allocated only for RS traffic. The DL Relay zone starts with the R-FCH burst followed by the relay broadcast information, such as R-MAP which conveys the transmission schedules in the relay zones.

Two or more new gaps are formed in the process, supporting the transceiver's Tx/Rx switching time and the specific ranging process, as follows:

- Relay Transmit/Receive Transition Interval (R-TTI) following a Tx zone, within the Access/Relay Intervals
- Relay Receive/Transmit Transition Interval (R-RTI) following a Rx zone, within the Access/Relay Intervals

A challenge arises from the requirement that the RSs have to be synchronized through the air interface. An NT-RS needs to transmit the frame start preamble like a BS. Consequently it cannot simultaneously receive the frame start preamble sent by its superordinate to maintain its own synchronization. To address this issue, a new relayamble is defined in 802.16j to provide an NT-RS a synchronization signal.

The relayamble was specified in order to allow the subordinated RSs to properly track the parent RS synchronization and thus to execute the time and frequency alignment with the rest of the network. While the initial synchronization is performed on the preamble, the synchronization tracking during relay operation is performed on this relayamble structure. The relayamble has a different pseudo-noise sequence than the access preamble, but it's based on the same type of subcarrier structure as the access preamble. The relayamble is configurable. It doesn't appear in every single frame. The maximal interval of between adjacent relayambles is 40 ms, which is equivalent to 8 frames for a frame length of 5 ms. The relayamble is located at the end of the last DL Relay zone.

3.2 Medium access control layer details

3.2.1 Initial network entry and topology discovery

When an MS attaches a network through an RS, the MR-BS has to know which RS directly connects the MS. This topology discovery is also performed during the MS network entry procedure.

Figure 5 shows an example of an MS network entry procedure which dictates four fundamental features.

1) Local Transmission Parameters Adjustment

After establishing synchronization with the RS, the MS starts a network entry procedure by sending an initial CDMA ranging code on the uplink ranging channel dedicated for this purpose.

When the RS detects from the received code that the MS needs to adjust frequency, timing and/or transmission power, it sends back an RNG-RSP message to instruct the MS to adjust transmission parameters and sends a code again. Bandwidth allocation for sending the RNG-RSP can be required by the RSs own scheduling decision. Meanwhile, an RS in centralized scheduling mode first needs to request bandwidth allocation to the MR-BS.

2) Admission Control

Upon successfully receiving a code, the RS may confirm with the MR-BS whether the new coming MS can be accepted before it sends an RNG-RSP with success status to the MS. The MR-BS will decide its acceptance based on available resources.

3) Topology Discovery

After successful adjustment of transmission parameters, MS sends an RNG-REQ message containing its MAC address. At this time, the MS has not been allocated any unique connection identifier (CID) and it uses a well-known CID, ranging CID, to send the message. The RS relays it to the MR-BS after changing the CID field in the header from the ranging CID to the RS basic CID so that the

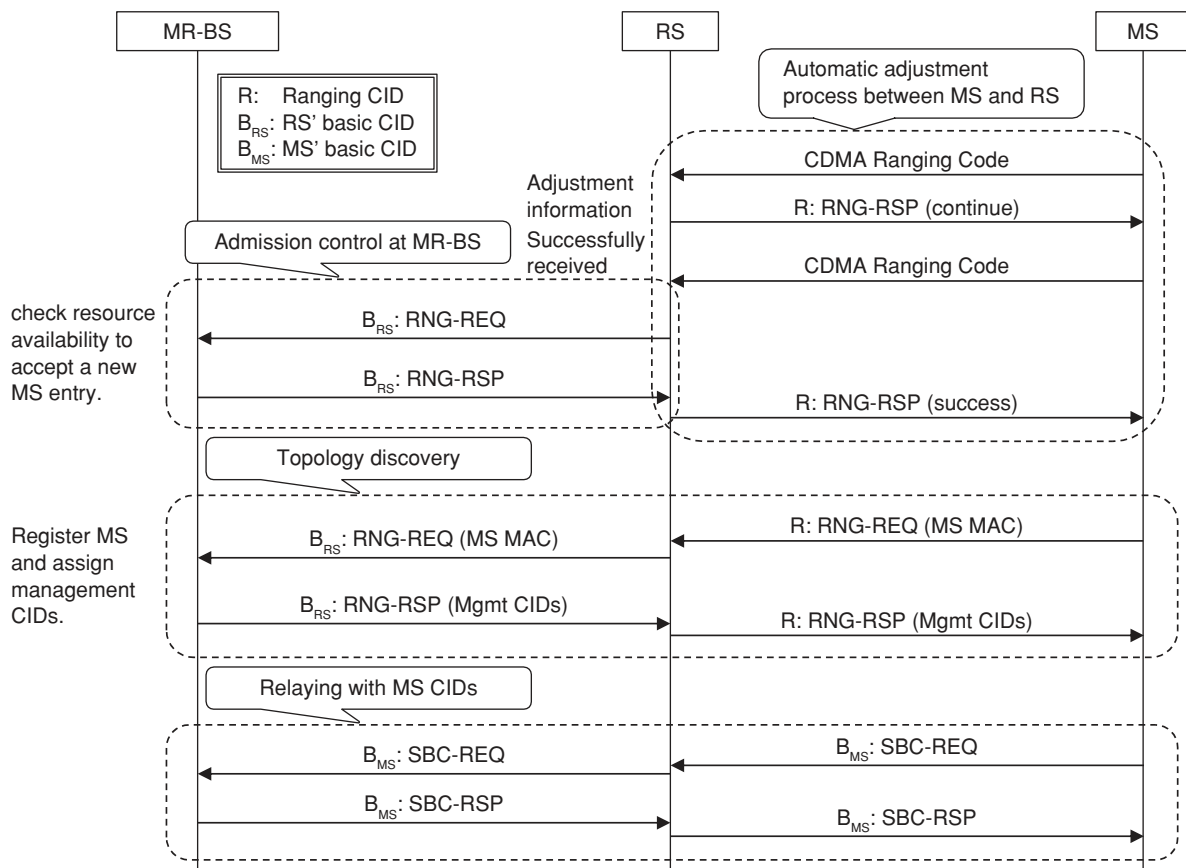

Figure 5 Adjustment of transmission parameters and topology discovery.

MR-BS can identify which RS directly communicates with the MS. After registering the MS MAC address and its parent RS, the MR-BS assigns MS management CIDs and sends them to the MS using the RNG-RSP message.

4) Data Relaying with MS CIDs

After management connections assignment, management messages are exchanged between MR-BS and MS through RS based on MS management CIDs.

3.2.2 Authentication and key management

Figure 6 shows an example of the conceptual procedure of authentication and key management in an entire access service network (ASN).¹⁰⁾

As in the case of the current 802.16e based systems, an authentication protocol, such as

EAP-TLS, is exchanged between an MS and an AAA server. When EAP authentication finishes successfully, the MR-BS generates an authentication key (AK) of the MS from a derivative of EAP authentication. At the same time, the MS also generates the AK.

After AK generation, the MR-BS transfers the AK to the RS while encrypting it with an RS key. Note that the RS has to have established a security association and share security keys with the MR-BS during its own network entry process.

Then, the MS and the RS perform a three-way handshake to confirm that both of them share the same security secret, AK, and establish security associations between them. At the request of the MS, the RS generates traffic encryption keys (TEKs) and sends them to MS with encryption protection.

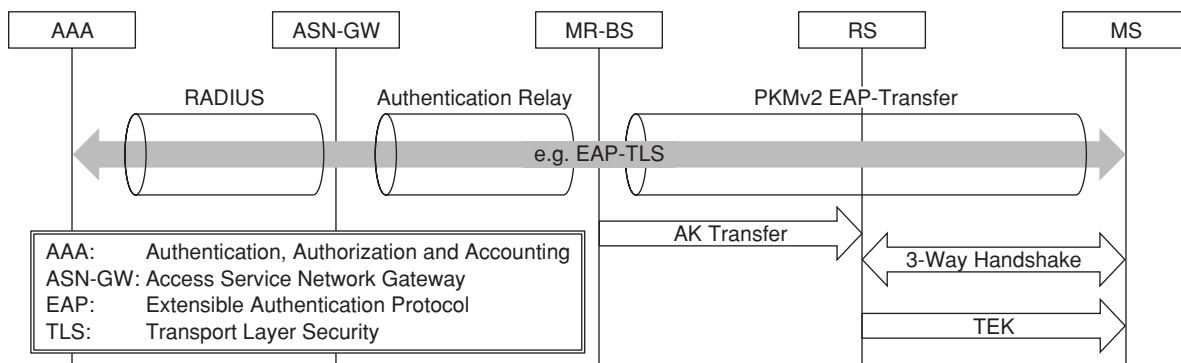

Figure 6 Authentication and key management procedure.

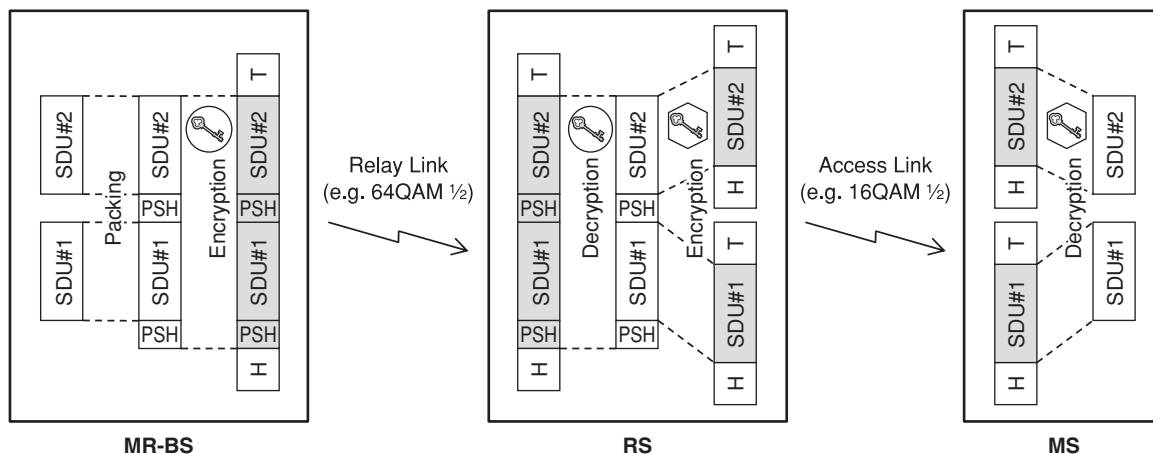

Figure 7 Example of DL transmission in a relay system in distributed security mode.

3.2.3 Data forwarding and encryption

Figure 7 shows an example of forwarding two service data units (SDUs), e.g. IP packets, from the MR-BS to the MS via the RS.

In general, it is beneficial to use a longer protocol data unit (PDU) on a relay link to minimize protocol overhead since a relay link is expected to have better channel conditions compared with an access link.

Therefore, in the example, the MR-BS concatenates two SDUs by attaching a packing subheader (PSH) to each one of them, encrypts the concatenated SDUs with the RS TEK and generates a longer PDU. The shaded part of the packet indicates an encrypted part.

The RS decrypts the received PDU and derives each SDU based on the attached PSH. After encrypting the SDUs separately with the MS TEK, the RS generates and transmits two PDUs one by one to accommodate the slower channel characteristic of the access link. The RS can split an SDU into multiple fragments if necessary.

4. Conclusion

The IEEE 802.16j amendment envisions RSs operating in Mobile WiMAX networks in order to expand the cell coverage and improve the throughput because of the enhanced link quality.

During the development of this standard,

four main operational types of RS are introduced based on the type of PHY architecture (transparent and non-transparent) and on the scheduling and security modes (centralized and distributed).

Depending on the network implementation scenarios, an RS could be an efficient solution for rolling out WiMAX networks. This paper particularly indicates that the T-RS and the NT-RS operating in centralized scheduling mode do not offer optimal performance for MS full-mobility applications although they could be cost-effective solutions for fixed/nomadic applications, under certain assumptions.

On the other hand, it appears that the NT-RS operating in distributed scheduling is well suited to supporting MS full-mobility applications because of its lower latency in modulation/coding adaptations. Furthermore, the distributed security mode can improve the bandwidth efficiency. Owing to the advantages mentioned above, it is expected that the NT-RS operating in distributed scheduling and security mode will be widely used in various environments.

References

- 1) IEEE-SA Standards Board: Get IEEE 802.16 LAN/MAN Broadband Wireless LANS. <http://standards.ieee.org/getieee802/802.16.html>
- 2) WiMAX Forum: WiMAX Forum Mobile System Profile, Release 1.0 Approved Specification (Revision 1.4), May 2007. http://www.wimaxforum.org/technology/documents/wimax_forum_mobile_system_profile_v1_40.pdf
- 3) M. Nakamura, et al.: Standardization Activities for Mobile WiMAX. *FUJITSU Sci. Tech. J.*, **44**, 3, p.285-291 (2008).
- 4) WiMAX Forum: A Comparative Analysis of Mobile WiMAX™ Deployment Alternatives in the Access Network, May 2007. http://www.wimaxforum.org/technology/downloads/mobile_wimax_deployment_alternatives.pdf
- 5) H. Zeng and C. Zhu: System-Level Modeling and Performance Evaluation of 802.16j Multi-hop Relay Systems. Proceeding of IWCMC, Next Generation Mobile Networks Symposium, August 2008.
- 6) IEEE-SA Standards Board: P802.16j PAR. <http://standards.ieee.org/board/nes/projects/802-16j.pdf>
- 7) IEEE 802.16: IEEE Std 802.16j. <http://www.ieee802.org/16/pubs/80216j.html>
- 8) WiMAX Forum: WiMAX System Evaluation Methodology. Version 1.0, January 2007.
- 9) IEEE 802.16j TG: Multi-hop Relay System Evaluation Methodology (Channel Model and Performance Metric). IEEE 802.16j-06/013r3, February 2007. http://www.ieee802.org/16/relay/docs/80216j-06_013r3.pdf
- 10) -: WiMAX Forum Network Architecture Stage 2-3: Release 1, Version 1.2. January 2008. http://www.wimaxforum.org/technology/documents/WiMAX_Forum_Network_Architecture_Stage_2-3_Rel_1v1.2.zip



Masato Okuda

Fujitsu Laboratories Ltd.

He has received the B.E. and M.E. degrees from Waseda University, Tokyo, Japan in 1991 and 1993 respectively. He joined Fujitsu Laboratories in 1993. Since then he has been engaged in research on broadband access systems based on ATM, IP/Ethernet and WiMAX. From 1998 to 1999, he was a visiting scholar in Stanford University, California, USA. He is a member of the Institute of Electronics, Information and Communication Engineers (IEICE) of Japan. He received the Young Engineers Award from the IEICE in 1997.



Dorin Viorel

Fujitsu Microelectronics Canada.

He has received the M.Sc. in Applied Electronics from the Technical University of Timisoara, Romania, in 1983. Between 1983 and 1997, he was employed by Romanian Radiocommunications Company, covering Network Performance Measurements and later NOC Senior Manager Attributions. Between 1997 and 2001 he worked for Nortel as a test analysis expert and technical advisor, focusing on LMDS systems. Between 2001 and 2003, Dorin worked for Quake Technologies (AMCC) as an evaluation engineer. Since October 2004, he has been with Fujitsu Microelectronics Canada (initially Wi-LAN), as a senior system engineer, targeting fixed and Mobile WiMAX systems.



Chenxi Zhu

Fujitsu Laboratories of America.

He has received the B.Sc. from Tsinghua University, Beijing, China in 1993, the M.Sc. from University of Guelph, Canada in 1996 and the Ph.D. degree in Electrical Engineering from University of Maryland, College Park in 2001. From 2001 to 2004 he was with Flarion Technologies, Bedminster, New Jersey working on flash-OFDM, an OFDMA-based mobile broadband wireless access technique. Since October 2004 he has been with Fujitsu Laboratories of America, College Park, where he has been working on system design of wireless networks, including WLAN and WiMAX.