

Multispectral color imaging for dermatology: application in inflammatory and immunologic diseases

Masahiro Yamaguchi⁽¹⁾²⁾, Masanori Mitsui⁽¹⁾, Yuri Murakami⁽¹⁾²⁾, Hiroyuki Fukuda⁽²⁾, Nagaaki Ohyama⁽¹⁾²⁾, and Yasuo Kubota⁽³⁾

1) Imaging Science and Engineering Laboratory, Tokyo Institute of Technology

4259-R2-56 Nagatsuta, Midori-ku, Yokohama 226-8503, Japan

E-mail: guchi@isl.titech.ac.jp

2) Akasaka Natural Vision Research Center, NICT, Japan

3) Department of Dermatology, School of Medicine, Kagawa University

Abstract

This paper presents an experimental investigation of the application of multispectral imaging in dermatology. The focus areas of this work are as follows: a) the improving the color reproduction accuracy of skin lesions, b) exploring the spectral feature of skin disease using the multispectral color enhancement technique, and c) multispectral image analysis aiming at supporting quantitative diagnosis. The experiment focused on inflammatory and immunologic diseases; the color of skin lesions associated with these diseases is believed to be difficult to reproduce by conventional imaging devices. In view of this fact, we demonstrate the effectiveness of using spectral information for the color reproduction and quantitative analysis of skin disorders.

1. Introduction

The color of skin lesions is of great importance in dermatology. The lesion size is determined by a slight color difference and the accurate observation of skin color can help in determining whether the lesion is benign or malignant. In dermatology, highly accurate color reproduction is required for photographic image recording.

Digital imaging technology is applied to dermatology for constructing an image and teledermatology. Proper advice by expert dermatologists can be obtained via teledermatology^[1,2]; this is particularly useful when the diagnosis of skin disease is relatively difficult for general physicians. The utilization of such digital imaging systems can improve the quality of medical services. However, the color of the reproduced image is not accurate in conventional color imaging systems, and it has been determined that the condition of skin lesions cannot be well rendered by conventional digital images^[3].

High-fidelity color reproduction technology is required in various fields such as printing, electronic commerce, and the digital archiving of artworks or cultural heritages. For the accurate reproduction of the original color through digital imaging systems, the multispectral imaging technology is promising^[4-7]. By using the spectral information, the reproduced color accuracy is considerably improved as compared to conventional RGB-based systems; moreover, the quantitative spectral information can be

employed for the analysis or the information retrieval from the image database.

Multispectral imaging technology has been applied to dermatology mainly for the diagnosis of melanomas^[8]. It has also been used to estimate the oxygen saturation of blood, based on the spectral characteristics of oxy- and deoxy-hemoglobin^[9]. We are also conducting experiments aimed at the application of multispectral imaging to high-fidelity color reproduction and diagnostic support for skin diseases. In this paper, we address the inflammatory and immunologic diseases because they render subtle color variation, which is difficult to be reproduced by conventional RGB imaging. We demonstrate the experimental results of the color reproduction accuracy of skin diseases as well as the visualization and quantification of the lesions by using a 16-band multispectral camera.

2. Multispectral imaging system

The multispectral imaging system used in this experiment comprises a 16-band high-resolution multispectral camera (MSC)^[10] and a multispectral image database based on the system developed by Akasaka Natural Vision Research Center (NVRC), National Institute of Information and Communication Technology (NICT). The configuration of the 16-band MSC is shown in fig.1; a filter wheel with 16 interference filters is attached, and an image with 12-bit gray level and a resolution of 2048 × 2048 pixels for each band can be captured. Figs. 2 and 3 show the appearances of the MSC and the experimental setup at the consulting room in the Department of Dermatology, Kagawa University Hospital. Two tungsten lamps are used for the illumination, and the spectral energy distribution of the illumination light is measured by using a standard white plate.

Although it is possible to attach either a telephoto lens or a wide-angle lens to the MSC, we use the former to fill the frame with a 150 mm × 150 mm area due to the limitation in the room size and the magnification expected by dermatologists. Since it takes about 10 s to capture a 16-band image with the rotating filter wheel, the patient must not move during the exposure. To avoid motion blur, a small lamp and buzzer are used to capture the patient's attention during the period when the patient has to keep still. In addition, a frame that is slightly larger than the area to be photographed is placed, and the patient is allowed to place the region of the lesion on the frame so that the image can be captured without adjusting

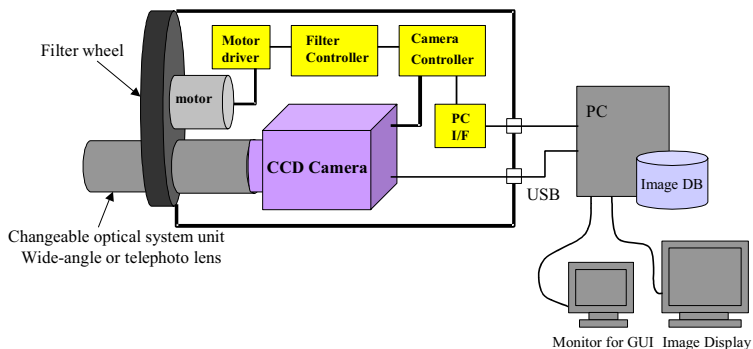

Figure 1 System configuration of multispectral imaging system developed for dermatology applications.

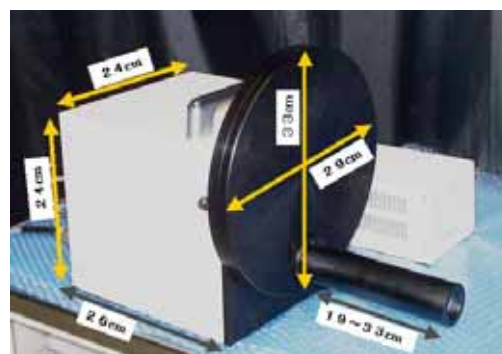

Figure 2 16band Multispectral camera

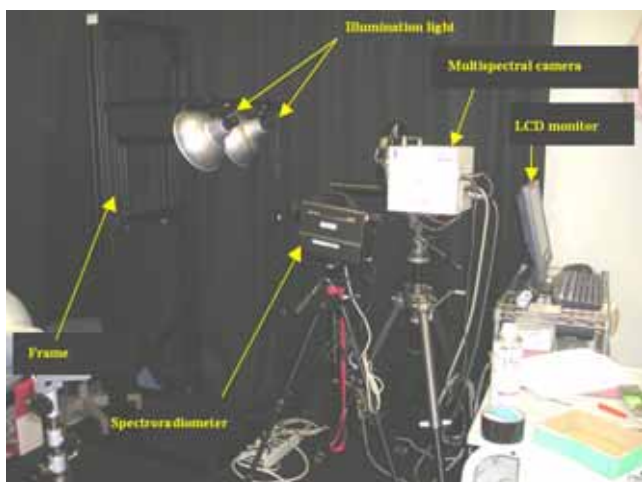

Figure 3 Experimental setup at the consultation room in the Department of Dermatology, Kagawa University hospital.



Figure 4 Screen capture of image database system. In this system, the user dermatologist specifies the region of interest (blue mark in the image), and image-based retrieval can be done by the spectral similarity of the specified regions.

the framing or focusing. Although it is impossible to photograph lesions in some cases due to the difficulty of positioning, we have limited the target regions in this experiment to those that can be captured by this system, such as hand, arm, back, and face.

Captured images are stored in the image database in the Natural Vision data format (NV format)^[11], developed by the NVRC. The NV format contains profile information of the image capturing setup, such as the spectral sensitivity of each band and the spectral radiance of illumination, in addition to multispectral image data. Using the profile data, the stored image can be utilized for the natural color reproduction and for image analysis using quantitative color information.

In the database system, the multispectral image is associated with the patient and his or her clinical information. Hence, a clinical case can be retrieved from the database by using a combination of a text-based search using the patient's clinical information and an image-based search with spectral features of the skin disease. Fig.4 shows a screen capture of the image database, in which the region of interest can be selected using the segmentation algorithm based on spectral reflectance. In addition, related clinical cases are retrieved by the similarity of spectral features, which are

independent of the imaging device and the illumination environment.

3. Color reproduction accuracy of skin diseases

Although there have been many reports on the color reproduction of human skin, most of them deal with the skin of healthy people. From the analysis using the spectral reflectance of normal skin, it has been shown that fair color reproducibility can be achieved from even a three-band image if the prior information (i.e., basis functions or covariance matrix) on skin reflectance has been provided in the color estimation. On the other hand, the spectral characteristics of abnormal skin have not yet been well investigated in detail. Even though a multispectral image with enough number of bands imparts high color reproducibility, the number of bands required to attain a compact and inexpensive imaging device is expected to be reduced. However, the requirements of the number of bands and the accuracy of color reproducibility have not been clarified to date.

In this experiment, we investigated the color reproduction accuracy by using a 16-band multispectral image, which is considered to achieve a sufficiently high accuracy of color reproduction. As the first step of the experiment, spectrum-based

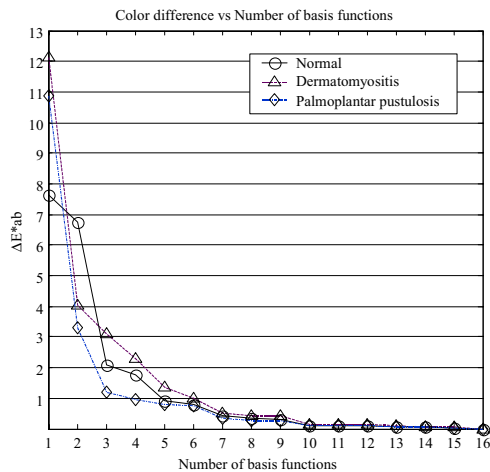

Figure 5 CIE color difference between the colors reproduced by the original 16-band multispectral image and K ($K = 1 \dots 16$) basis functions derived from normal skin—for normal, dermatomyositis and palmoplantar pustulosis cases.

color reproduction was applied to the 16-band image of skin diseases and displayed on a flat panel LCD after color calibration by spectral characterization. Through visual evaluation by dermatologists, it was confirmed that excellent color reproducibility is realized in the clinical images—even better than images captured on reversal films. In the next step of the experiment, a computer simulation to estimate the color reproduction accuracy when using a smaller number of bands was carried out; the color reproduced by the 16-band multispectral image was considered as the gold standard.

In the computer simulation, the pixel value of the 16-band multispectral image that was divided by the spectral radiance of the standard white plate was regarded as the 16-dimensional spectral reflectance. We used the 16-dimensional basis functions derived by the principal component analysis (PCA) of the spectral reflectance of normal skins measured previously^[12]. The spectral reflectance of normal and abnormal skin were obtained from the images and expanded by the basis functions. The color reproduction accuracy was subsequently evaluated as the color difference between the tristimulus values reproduced from original 16-band image and the coefficients for the limited number of basis functions.

Fig.5 shows the relationship between the number of basis functions and the average color difference (CIE ΔE^*_{ab} under CIE D65 illuminant) for the cases of normal skin, palmoplantar pustulosis, and dermatomyositis. The number of basis functions required for a certain color estimation accuracy approximately corresponds to the required number of bands for the imaging device, under the assumption of using the basis functions for color estimation. Therefore, fig.5 roughly indicates the lower limit of the color difference when using the camera with K bands.

Fig.6 illustrates the color difference when using three basis functions, which corresponds to the case of a three-band camera, for various types of skin diseases. Inflammatory diseases (psoriasis

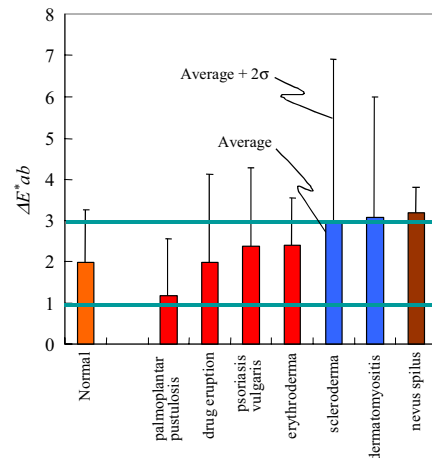

Figure 6 CIE color difference between the colors reproduced by the original 16-band multispectral image and three basis functions derived from normal skin. Bold bars represent the average and thin bars represent average + (standard deviation) $\times 2$ color differences of several areas selected from the images.

vulgaris, palmoplantar pustulosis, erythroderma, and drug eruption) and immunologic diseases (scleroderma and dermatomyositis) exhibit different traits, namely, the colorimetric error is larger in immunologic diseases than in inflammatory cases. The color differences in immunologic disease cases are larger than the discrimination threshold of human vision when three basis functions are used. The reason for this phenomenon is interpreted as follows.

The spectral reflectance is affected by the morphological structure inside the skin, i.e., the disorder located in a deep region, such as hypodermis or muscles in the case of scleroderma and dermatomyositis, while dermatitis mainly affects the superficial layers around the epidermis and the basal layer. Due to the wavelength dependency of light scattering in the skin, long wavelength light penetrates deeper regions than short wavelength light. In immunologic diseases, specific textural features such as collagen disorders in relatively deep regions cause different light transport characteristics especially for long wavelength, and the spectral transmittance is not well described by the basis functions of normal skin. In these cases, more than five bands are required to achieve the colorimetric accuracy equivalent to the case in which normal skin is photographed by a three-band camera.

4. Color enhancement of multispectral image

Since the color of skin is determined by the distribution of hemoglobin and dyes such as melanin as well as the wavelength dependency of light scattering inside the skin, there may be a strong relation between the condition of skin disease and the spectral feature of reflected light. However, the spectral feature associated with the diagnosis has not yet been determined. In this research, we conducted an experiment to explore the spectral feature of skin lesions using 16-band multispectral image presented above.

One of the difficulties in observing the features in the spectral reflectance is the individual variation in the normal skin color. To

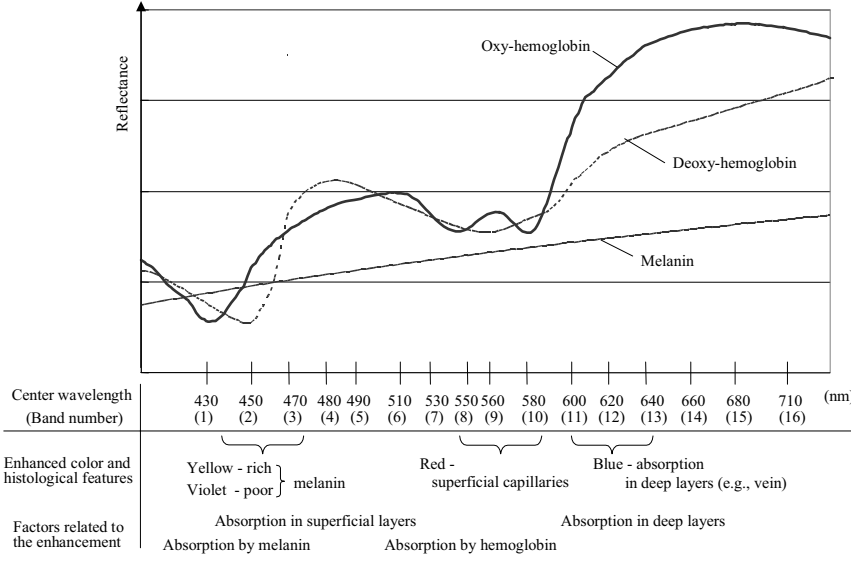

Figure 7 The wavelength and enhanced features. The horizontal axis represents the center wavelength of each band of MSC [(1)–(16)]. The plots are the spectral reflectance of melanin and hemoglobin media calculated from the absorption coefficients of the dyes. Since the short wavelength light does not penetrate deeper due to the light scattering property inside the skin, the influence of absorption at superficial layers are dominant in short wavelength, while the influence of deep layers appear in long wavelength components. According to these considerations, the features visualized by enhancing certain wavelength regions are also depicted.

visualize the spectral feature along with suppression of normal color variation, we applied a color enhancement technique for the multispectral image^[13], in which a specific wavelength component is enhanced; however, the color of the normal region is kept unchanged. The method is described below.

Let us consider that a PCA is applied to N -band multispectral pixel values $\mathbf{g}(\mathbf{r})$, where \mathbf{r} is a position vector in the image. Then, $\mathbf{g}(\mathbf{r})$ can be expressed by a linear combination of N basis vectors (\mathbf{u}_i , $i = 1 \dots N$) as follows:

$$\mathbf{g}(\mathbf{r}) = \sum_{i=1}^N \alpha_i(\mathbf{r}) \mathbf{u}_i \quad (1)$$

where $\alpha_i(\mathbf{r})$ is a coefficient for every pixel and i -th basis vector. If the pixels used in the PCA are obtained from the normal part, then the basis vectors with larger eigenvalues represent the spectral characteristics of the normal part. Let $\mathbf{g}_p(\mathbf{r})$ denote multispectral pixel values reconstructed from only the top $m (< N)$ significant basis vectors:

$$\mathbf{g}_p(\mathbf{r}) = \sum_{i=1}^m \alpha_i(\mathbf{r}) \mathbf{u}_i \quad (2)$$

Then, $\mathbf{g}_p(\mathbf{r})$ is subtracted from the multispectral pixel value so that the spectral difference from the normal part is extracted as

$$\begin{aligned} \Delta \mathbf{g}(\mathbf{r}) &= \mathbf{g}(\mathbf{r}) - \mathbf{g}_p(\mathbf{r}) \\ &= \sum_{i=m+1}^N \alpha_i(\mathbf{r}) \mathbf{u}_i \end{aligned} \quad (3)$$

where $\Delta \mathbf{g}(\mathbf{r})$ is termed as the differential multispectral image in this paper. To visualize the image feature corresponding to respective wavelength bands, a specified wavelength component is enhanced by multiplying an appropriate weighting factor to the corresponding element of $\Delta \mathbf{g}(\mathbf{r})$. The resultant image, i.e. a

differential multispectral image where a specific wavelength component is enhanced, denoted as $\Delta \mathbf{g}_e(\mathbf{r})$, is added to $\mathbf{g}_p(\mathbf{r})$ to obtain the enhanced multispectral image $\mathbf{g}_e(\mathbf{r})$:

$$\mathbf{g}_e(\mathbf{r}) = \Delta \mathbf{g}_e(\mathbf{r}) + \mathbf{g}_p(\mathbf{r}) \quad (4)$$

The color image is generated under the assumption that $\mathbf{g}_e(\mathbf{r})$ is an image virtually obtained from an MSC, and a color reproduction algorithm for multispectral image is applied^[7]. Since this method enhances higher order components, it is suitable for finding subtle changes from the spectral image that has spatial color variations.

On considering the application of this method to the multispectral image of skin, the spectral feature of abnormal part is enhanced as the difference from the normal skin, depending on the specified wavelength. In view of the fact that long wavelength red light penetrates deeper than short wavelength blue light and considering the spectral absorbance characteristics of melanin and hemoglobin, the enhanced image will exhibit the spectral features shown in fig.7. It is expected that the quantity of melanin in the superficial layer will be observed in the component at approximately 470 nm, the density of blood capillaries is reflected at approximately 550 nm, and blood vessels such as veins in relatively deep regions are enhanced in the 620-nm component.

In fig.8, the results of spectral color enhancement applied to the clinical image of psoriasis vulgaris are shown. In this case, m in eq. (2) is set to be 3. The region of vascular dilatation and proliferation are vividly visualized by the 550-nm enhancement. Fig.9 shows the result of dermatomyositis, which is one of the systemic autoimmune disorders. In contrast to the case of psoriasis where the clarity of the enhanced region is better at 550 nm than 580 nm, in the case of dermatomyositis, the 580-nm image exhibits the lesions more clearly than 550-nm image. This can be explained by similar characteristics mentioned in section 3, namely, the spectral feature appears longer wavelength since deep

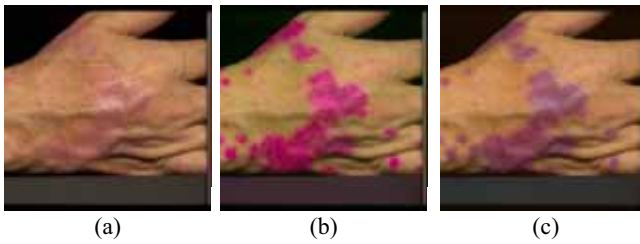

Figure 8 Color reproduction (a) result; (b) 550-nm and (c) 580-nm enhanced images of psoriasis vulgaris.

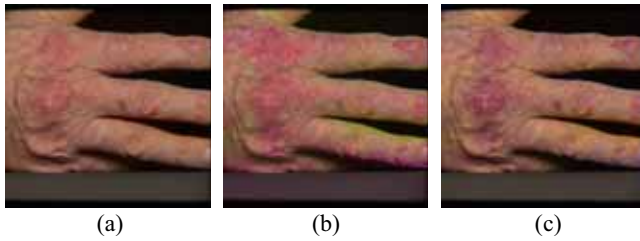

Figure 9 Color reproduction (a) result; (b) 550-nm, (c) 580-nm enhanced images of dermatomyositis.

regions such as muscles and hypodermis are affected in this type of disorder.

Through this experiment, the spectral color enhancement technique has been shown to be useful for investigating the spectral feature of skin lesions. The possibility of applying multispectral imaging technology for the quantification or classification of skin lesions such as psoriasis using the 550-nm wavelength component and suppressing the normal variation of spectral reflectance has been demonstrated. It has been also demonstrated that the color difference between inflammatory diseases such as psoriasis and immunologic diseases such as dermatomyositis can be evaluated using multispectral images.

The color enhancement technique can be also applied to support the diagnosis via the image-based telemedicine system. There are difficulties in the communication between remote sites through the network because of limitations in the observation flexibility and the absence of tactile information. Thus, it would be valuable to send a spectral image and visualize supplementary images with a specific wavelength enhanced, along with the natural color image. It is expected that with the availability of supplementary information on the features of the skin lesions, a more precise recognition of the condition of skin disease would be possible.

5. Application in diagnostic support in dermatology

In this section, an example of computerized diagnostic support using the multispectral image is presented. The differential multispectral image $\Delta g(\mathbf{r})$ introduced in section 4 expresses the features of the skin lesion when the variation of normal color is removed. Let us consider the application of the differential multispectral image to computerized diagnostic support in dermatology as shown in fig.10. By choosing one or several wavelength components that contain characteristic information on a specific disorder, it will be possible to extract the abnormal

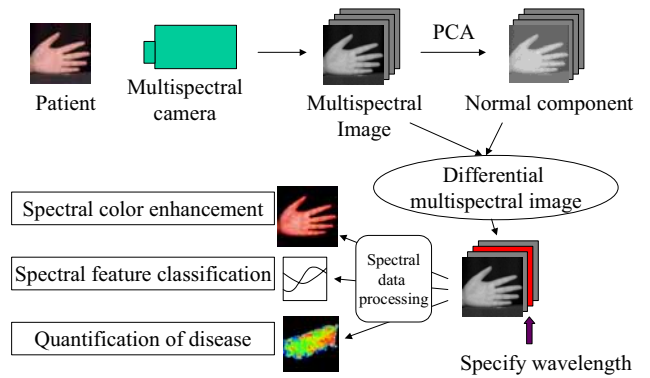

Figure 10 Proposed algorithm for multispectral skin color analysis.

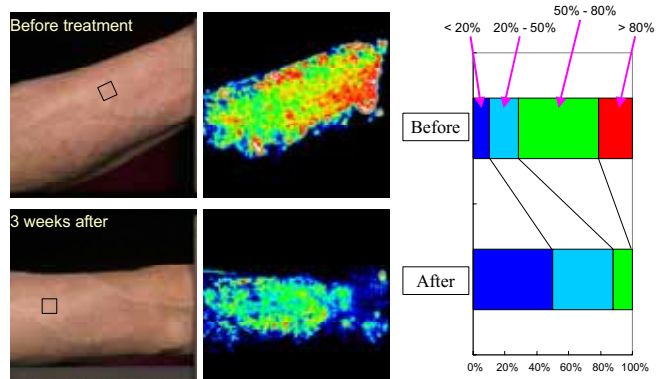

Figure 11 Example of application: visualizing blood quantity. The images on the left are the photographs of the same patient with psoriasis captured at different times (before treatment and 3 weeks after). The images in the middle show the blood quantity distribution, where the density of blood-rich region is expressed by pseudo color encoding. The ratio of density in the corresponding image areas is shown in bar graphs on the right.

region, or to derive quantitative information for differential diagnosis.

In fig.10, the normal component is derived from PCA of original multispectral image. However, a set of basis functions yielded from PCA can be used for the images of other patient or other diseases in principle. Since the result of differential multispectral image depends on the selection of normal part from the image, it is needed to address a method to define the basis functions that gives robust and accurate result independent on the patient and disease in future.

We have implemented an algorithm to extract the regions where the blood quantity is increased. In the algorithm, pixels larger than certain threshold values (blood-rich pixels) are obtained from the 550-nm component of the differential multispectral image. Subsequently, a small window is set around every pixel, and all the pixels are classified according to the density of the blood-rich pixels within the window. Fig.11 demonstrates the application of this method to the images of psoriasis vulgaris captured at different times: before the treatment and three weeks after. In fig.11, the density of blood-rich pixels is expressed as 0–100%, and the pseudo color images clearly exhibit the conditions of

psoriasis. If the imaged region can be adjusted, quantitative evaluation in the form of bar charts in the right side of fig.11 will be possible. In this experiment, since automatic adjustment was difficult, corresponding regions between two images were manually selected (as marked in the images on the left side) and the results in these small regions are plotted in the bar charts. For practical application, a larger region, e.g., a whole arm should be evaluated. Although there are a substantial number of issues to be addressed, it has been shown that the analysis of multispectral image provides effective information for supporting diagnosis in dermatology, such as the grading of disorders or the quantitative evaluation of treatments.

6. Conclusion

In this paper, we present the application of multispectral imaging to color reproduction, color enhancement, and image analysis for dermatology, focusing on inflammatory and immunologic disorders that exhibit subtle color appearance. Through the experiment on color estimation, we show that the spectral reflectance has different characteristics in normal and abnormal skin depending on the types of disorders. Especially for scleroderma and dermatomyositis, it can be predicted that three-band cameras indicate a visually apparent error in color reproduction. It is also demonstrated that the application of the spectral color enhancement technique is useful for investigating spectral features of abnormal parts even if the normal parts have color variations. Specific wavelength components of the differential spectral reflectance can be also employed for the quantifying or grading of skin disease.

In some types of skin diseases, irregular spectral features are observed as the optical properties of tissue changes from normal skin. Spectral images hold not only the information on dye distribution but also the histological structure of skin disease. Such spectral features have not been revealed yet, such as light scattering in the layered structure. Although further investigation is expected, multispectral imaging is an effective tool for capturing the information useful for dermatology.

Although an MSC with a rotating filter wheel is not suitable in practice, recently, a 6-band MSC for moving images has also been developed^[14]. For practical application of the presented technique in dermatological diagnosis, compact and user-friendly devices for multispectral image capture are necessary. In this aspect, a high-performance MSC with smaller number of bands is required. When examining the reduction in the number of bands, 16-band multispectral images of abnormal skins are also useful for evaluating the performance of the imaging device with smaller number of bands.

Digital photography with high color reproducibility that enables quantitative image analysis is quite beneficial in dermatology and other fields. To put this technology into practical use, the clinical evaluation is an essential issue for future work in addition to the development of handy imaging devices.

This work is supported by the Special Coordination Funds for Promoting Science and Technology of the Ministry of Education, Culture, Sports, Science and Technology, conducted as a joint project of Tokyo Institute of Technology, NTT Data Corp., and Olympus Co. in collaboration with NVRC of the National Institute of Telecommunication and Communication Technology (NICT) and Kagawa University. The authors wish to acknowledge Toshihiko Numahara, MD, for valuable discussions and Yoshifumi Kanno of NTT Data Corp. and Yasuhiro Komiya of Olympus Co. for technical support.

References

1. D. J. Eedy and R. Wootton, "Tele dermatology: a review," *British J. of Dermatology*, Vol.144 (2001) 696-707
2. E. A. Krupinski, B. LeSueur, L. Ellsworth, N. Levine, R. Hansen, N. Silvis, P. Sarantopoulos, P. Hite, J. Wurzel, R. S. Weinstein and A. M. Lopez, "Diagnostic accuracy and image quality using a digital camera for Tele dermatology," *Telemedicine Journal*, Vol.5, No.3 (1999) 257-263
3. T. Numahara, "From the standpoint of Dermatology," in *Digital Color Imaging in Biomedicine*, H. Tanaka, Y. Miyake, M. Nishibori, and D. Mukhophadhay, eds., *Digital Biocolor Society*, (2001) 67-72, <http://biocolor.umin.ac.jp/book200102/din01022812.pdf>
4. H. Haneishi, T. Hasegawa, A. Hosoi, Y. Yokoyama, N. Tsumura, and Y. Miyake, "System design for accurately estimating the spectral reflectance of art paintings," *Appl. Opt.*, Vol.39, No.35, (2000) 6621-6632
5. B. Hill, "Color capture, color management and the problem of metamerism: does multispectral imaging offer the solution?" *Proc. SPIE*, 3963, (2000) 2-14
6. P. D. Burns and R. S. Berns: "Analysis of multispectral image capture," *Proc. 4th Color Imaging Conference*, (1996) 19-22,
7. M. Yamaguchi, T. Teraji, K. Ohsawa, T. Uchiyama, H. Motomura, Y. Murakami, and N. Ohya, "Color image reproduction based on the multispectral and multiprimary imaging: Experimental evaluation," *Proc. SPIE*, vol.4663, (2002) 15-26
8. S. Tomatis, A. Bono, C. Bartoli, M. Carrara, M. Lualdi, G. Tragni, and R. Marchesini, "Automated melanoma detection: multispectral imaging and neural network approach for classification," *Med Phys.* Vol. 30, No.2: (2003) 212-21
9. N. Tsumura, N. Ojima, K. Sato, M. Shiraiishi, H. Shimizu, H. Nabeshima, S. Akazaki, K. Hori, and Y. Miyake, "Image-based skin color and texture analysis/synthesis by extracting hemoglobin and melanin information in the skin," *ACM Transactions on Graphics*, Vol. 22, No. 3 (2003) 770-779
10. H. Fukuda, T. Uchiyama, H. Haneishi, M. Yamaguchi, and N. Ohya, "Development of 16-bands multispectral image archiving system," *Proc. SPIE*, Vol.5667 (2005) 136-145
11. H. Motomura, K. Ohsawa, N. Ohya, M. Yamaguchi, and H. Haneishi, "Natural Vision image data file format for spectral-based color reproduction system," *Proc. PICS*, (2003) 278-284
12. Y. Ohya, T. Obi, M. Yamaguchi, N. Ohya, and Y. Komiya, "Natural color reproduction of human skin for telemedicine," *Proc. SPIE*, Vol.3335, (1998) 263-270
13. M. Mitsui, Y. Murakami, T. Obi, M. Yamaguchi and N. Ohya, "Color enhancement in multispectral image using the KL transform," *Optical Review*, Vol.12, No.2 (2005) 69-75
14. K. Ohsawa, T. Ajito, H. Fukuda, Y. Komiya, H. Haneishi, M. Yamaguchi, and N. Ohya, "Six-band HDTV camera system for spectrum-based color reproduction," *J. Imaging. Sci. and Technol.*, vol.48, no.2, (2004) 85-92