

## MUTUAL INDUCTANCE AND FORCE EXERTED BETWEEN THICK COILS

**R. Ravaud, G. Lemarquand, and V. Lemarquand**

Laboratoire d'Acoustique de l'Universite du Maine  
UMR CNRS 6613 Avenue Olivier Messiaen, Le Mans 72085, France

**S. Babic and C. Akyel**

Ecole Polytechnique, Département de Génie Physique  
QC H3C 3A7, Montréal, Canada

**Abstract**—We present exact three-dimensional semi-analytical expressions of the force exerted between two coaxial thick coils with rectangular cross-sections. Then, we present a semi-analytical formulation of their mutual inductance. For this purpose, we have to calculate six and seven integrations for calculating the force and the mutual inductance respectively. After mathematical manipulations, we can obtain semi-analytical formulations based on only two integrations. It is to be noted that such integrals can be evaluated numerically as they are smooth and derivable. Then, we compare our results with the filament and the finite element methods. All the results are in excellent agreement.

### 1. INTRODUCTION

Various electromagnetic applications are composed of two thick coils that form a loosely coupled transformer. The first coil generates a magnetic field in all points in space, and this magnetic field is partly picked up by the secondary coil. This is an efficient way of transferring power wirelessly. However, a decrease in power transfer efficiency can be caused by a lower mutual inductance between two coils [1, 2]. In other words, it is very useful to know the accurate value of the mutual inductance or the force exerted between two coils. Indeed, the force is directed linked to the mutual inductance as it is proportional to its gradient.

---

Corresponding author: G. Lemarquand (guy.lemarquand@univ-lemans.fr).

The calculation of mutual inductance for circular coils has been studied by many authors [3–12]. These papers are generally based on the application of Maxwell's formula, Neumann's formula and the Biot Savart law. By using these approaches, the mutual inductance of circular coils can be expressed in terms of analytical and semi-analytical functions, as the elliptic integrals of the first, second and third kind, the Heumann's Lambda function or the Bessel functions [13–15]. Such analytical methods are also suitable for calculating the magnetic near-field or far-field from circular cylindrical magnetic sources [16–19] or for the determination of the forces exerted between them [20–25]. On the other hand, authors generally use the finite element method or the boundary element method for solving such magnetostatic problems. However, as stated in [26], it is interesting to obtain analytical or semi-analytical exact expressions having a lower computational cost for optimization purposes.

In this paper, we propose to replace each coil by a toroidal conductor carrying uniform current volume density for calculating both the force exerted between two thick coils and their mutual inductance. These toroidal conductors are assumed to be perfectly circular and radially centered. We define an equivalent current volume density  $j$  which is linked to the number of loops and the coil dimensions. We use the Lorentz force for evaluating the exact axial force exerted between two thick coils carrying uniform current volume densities. We obtain a semi-analytical expression of the force that requires only two numerical integrations. However, its computational cost remains very low compared to the finite element method one as we need only about 0.05 s for calculating the axial force for a given configuration. Then, we compare our semi-analytical approach with the filament method. This comparison is a way for us to verify the accuracy of our semi-analytical model and to study the differences that occur between these three methods when two coils are close to each other. The analytical and numerical simulations are in very good agreement.

The second part of this paper deals with the analytical calculation of the mutual inductance of two thick coils in air. We use the potential vector and the Stoke's Theorem for reducing the number of numerical integrations required for evaluating this mutual inductance. We obtain a semi-analytical expression based on two numerical integrations. However, its computational cost remains very low (less than 0.5 s). Furthermore, we do not use any simplifying assumptions in the integral formulations of the mutual inductance. Then, we compare our approach with both the finite element method and a method proposed by Kajikawa [27, 28]. Here again, the results are in excellent agreement and show that our approach is exact.

## 2. AXIAL FORCE FORMULATION

We present in this section our three-dimensional analytical formulation for calculating the force exerted between two thick coils with rectangular cross sections. It is emphasized here that the two thick coils considered are replaced by two toroidal conductors having uniform current densities. However, for the rest of this paper, we will talk about thick coils rather than toroidal conductors.

### 2.1. Notation and Geometry

Let us first consider Fig. 1 where we have represented two thick coils carrying uniform current volume densities:

$$\mathbf{j}_1 = \frac{N_1 \mathbf{I}_1}{(r_2 - r_1)(z_2 - z_1)} \text{ and } \mathbf{j}_2 = \frac{N_2 \mathbf{I}_2}{(r_4 - r_3)(z_4 - z_3)}.$$

The parameters we use are defined as follows: For the lower coil, (respectively the upper one):  $r_1, r_2$  ( $r_3, r_4$ ) inner and outer radius

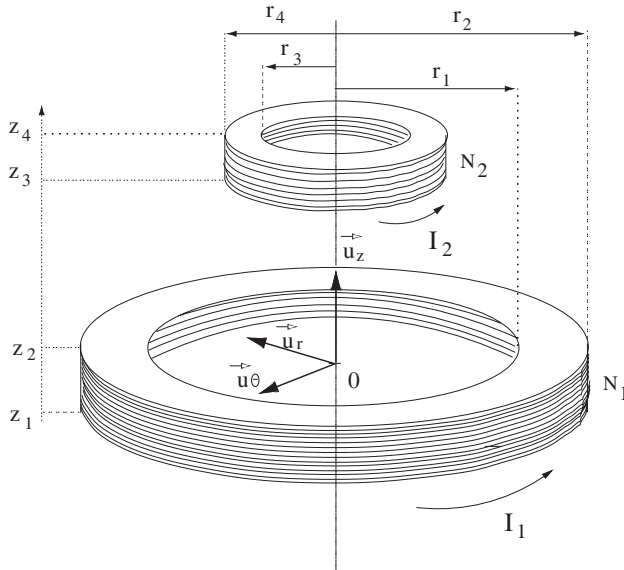

**Figure 1.** Geometry considered: Two thick coils carrying uniform current volume densities. For the lower thick coil, the inner radius is  $r_1$ , the outer one is  $r_2$ , the lower height is  $z_1$ , the upper one is  $z_2$ ; for the upper thick coil, the inner radius is  $r_3$ , the outer one is  $r_4$ , the lower height is  $z_3$ , the upper one is  $z_4$ .

[m],  $\mathbf{z}_1, \mathbf{z}_2$  ( $\mathbf{z}_3, \mathbf{z}_4$ ) lower and upper height [m],  $d = z_3 - z_2$ : Axial distance between the two thick coils [m].

## 2.2. Expressions of the Axial Force

The first step for calculating the axial force exerted between two thick coils is to express the magnetic induction field produced by the lower thick coil shown in Fig. 1. By using the Biot-Savart Law, the magnetic induction field  $\vec{B}_1$  is expressed as follows:

$$\vec{B}_1(\vec{r}, \vec{z}) = \frac{\mu_0}{4\pi} \iiint_{V_1} \vec{j}_1 d\vec{v}_1 \wedge \left\{ -\nabla G(\vec{r}, \vec{r}') \right\} \quad (1)$$

The axial force, exerted by coil 1 on coil 2, is derived with the following equation:

$$\vec{F} = \iiint_{V_2} \vec{j}_2 d\vec{v}_2 \wedge \vec{B}_1(\vec{r}, \vec{z}) \quad (2)$$

By inserting (1) in (2), we have:

$$\vec{F} = \iiint_{V_2} \vec{j}_2 d\vec{v}_2 \wedge \frac{\mu_0}{4\pi} \iiint_{V_1} \vec{j}_1 d\vec{v}_1 \wedge \left\{ -\nabla G(\vec{r}, \vec{r}') \right\} \quad (3)$$

where the Green's function  $G(\vec{r}, \vec{r}')$  is defined as follows:

$$G(\vec{r}, \vec{r}') = \frac{1}{\sqrt{\tilde{r}^2 + \tilde{r}'^2 - 2\tilde{r}\tilde{r}' \cos(\tilde{\theta}) + (\tilde{z} - \tilde{z}')^2}} \quad (4)$$

Therefore, (3) becomes:

$$\vec{F} = \frac{\mu_0}{4\pi} \iiint_{V_1} \iiint_{V_2} \vec{j}_2 d\vec{v}_2 \wedge \left\{ \vec{j}_1 d\vec{v}_1 \wedge \left\{ -\nabla G(\vec{r}'', \vec{r}') \right\} \right\} \quad (5)$$

We obtain the final expression:

$$\vec{F} = \frac{\mu_0}{4\pi} \iiint_{V_1} \iiint_{V_2} \vec{j}_2 \wedge \left\{ \vec{j}_1 \wedge \left\{ -\nabla G(\vec{r}'', \vec{r}') \right\} \right\} d\vec{v}_1 d\vec{v}_2 \quad (6)$$

where

$$d\vec{v}_1 d\vec{v}_2 = \tilde{r}\tilde{r}' d\tilde{r} d\tilde{r}' d\tilde{\theta} d\tilde{z} d\tilde{z}' d\tilde{\theta}' \quad (7)$$

In cylindrical coordinates,  $-\nabla G(\vec{\tilde{r}}, \vec{\tilde{r}})$  is reduced to the following form:

$$\begin{aligned}
 -\nabla G(\vec{\tilde{r}}, \vec{\tilde{r}}) = & \frac{\tilde{r} - \tilde{r} \cos(\theta)}{\left(\tilde{r}^2 + \tilde{r}^2 - 2\tilde{r}\tilde{r} \cos(\tilde{\theta}) + (\tilde{z} - \tilde{z})^2\right)^{\frac{3}{2}}} \vec{u}_r \\
 & + \frac{\tilde{r} \sin(\tilde{\theta})}{\left(\tilde{r}^2 + \tilde{r}^2 - 2\tilde{r}\tilde{r} \cos(\tilde{\theta}) + (\tilde{z} - \tilde{z})^2\right)^{\frac{3}{2}}} \vec{u}_\theta \\
 & + \frac{\tilde{z} - \tilde{z}}{\left(\tilde{r}^2 + \tilde{r}^2 - 2\tilde{r}\tilde{r} \cos(\tilde{\theta}) + (\tilde{z} - \tilde{z})^2\right)^{\frac{3}{2}}} \vec{u}_z
 \end{aligned}$$

By projecting  $\vec{j}_1, \vec{j}_2$  and  $-\nabla G(\vec{\tilde{r}}, \vec{\tilde{r}})$  in cartesian coordinates, we find the following form of the axial force exerted between two thick coils radially centered:

$$F_z = \frac{\mu_0 j_1 j_2}{4\pi} \iiint_{V_1} \iiint_{V_2} \frac{(\tilde{z} - \tilde{z}) \cos(\tilde{\theta}) \tilde{r} \tilde{r} d\tilde{r} d\tilde{\theta} d\tilde{z} d\tilde{r} d\tilde{\theta} d\tilde{z}}{\left(\tilde{r}^2 + \tilde{r}^2 - 2\tilde{r}\tilde{r} \cos(\tilde{\theta}) + (\tilde{z} - \tilde{z})^2\right)^{\frac{3}{2}}} \quad (8)$$

The previous relation can be directly reduced to the following form:

$$F_z = \frac{\mu_0 j_1 j_2}{2} \iiint_{V_1} \int_{r_3}^{r_4} \int_{z_3}^{z_4} \frac{(\tilde{z} - \tilde{z}) \cos(\tilde{\theta}) \tilde{r} \tilde{r} d\tilde{r} d\tilde{\theta} d\tilde{z} d\tilde{r} d\tilde{\theta} d\tilde{z}}{\left(\tilde{r}^2 + \tilde{r}^2 - 2\tilde{r}\tilde{r} \cos(\tilde{\theta}) + (\tilde{z} - \tilde{z})^2\right)^{\frac{3}{2}}} \quad (9)$$

After integrating with respect to  $\tilde{r}, \tilde{\theta}$  and  $\tilde{z}$ , we obtain the following reduced analytical expression of the axial force exerted between two thick coils radially centered:

$$F_z = \frac{\mu_0 j_1 j_2}{2} \int_{r_1}^{r_2} \int_{\theta_1}^{\theta_2} \sum_{i=1}^2 (-1)^i \sum_{j,k=3}^4 (-1)^{j+k} (f - g r_i^2 \cos(\theta)) \cos(\theta) dr d\theta \quad (10)$$

with

$$\begin{aligned}
 f = & -\frac{\alpha \zeta r_i}{2} + \frac{\beta}{2} \ln[\alpha + \zeta] \\
 g = & -z_j + \gamma \arctan\left[\frac{\zeta}{\gamma}\right] - \gamma \arctan\left[\frac{\epsilon \zeta}{\alpha \gamma}\right] \\
 & + \zeta \ln[\epsilon + \alpha] + \epsilon \ln[\zeta + \alpha]
 \end{aligned} \quad (11)$$

The parameters  $\alpha, \beta, \epsilon, \gamma, \zeta$  are defined in Table 1. It is emphasized here that Eq. (10) is an exact semi-analytical expression. This implies

**Table 1.** Definition of the parameters used in (10).

| Parameters |   |
|------------|---|
| $\alpha$   | $\sqrt{r^2 + r_i^2 - 2rr_i \cos(\theta) + (z_j - z_k)^2}$ |
| $\beta$    | $r^2 + r_i^2 - 2rr_i \cos(\theta)$                        |
| $\epsilon$ | $r - r_i \cos(\theta)$                                    |
| $\gamma$   | $r_i \sin(\theta)$  |
| $\zeta$    | $z_j - z_k$   |

that it can be used whatever the thick coil dimensions and may be used as a robust tool for evaluating the accuracy of any numerical methods.

### 3. COMPARISON OF THE AMPERIAN CURRENT MODEL AND THE FILAMENT METHOD

We present in this section a comparison between the amperian current model and the filament method for calculating the axial force exerted between two thick thick coils carrying uniform current volume densities. We compare two configurations and we discuss the accuracy of each method.

#### 3.1. First Configuration: Two Thick Coils Having the Same Dimensions

The first configuration consists of two thick coil having the same dimensions and the same uniform current volume densities. We take the following dimensions for our numerical simulations:

$$r_1 = r_3 = 0.0875 \text{ m}$$

$$r_2 = r_4 = 0.1125 \text{ m}$$

$$z_2 - z_1 = z_4 - z_3 = 0.025 \text{ m}$$

$$j_1 = j_2 = 320000 \text{ A/m}^2, I = 1 \text{ A}, N = 200 \text{ turns}$$

$$d = \text{axial distance between the two thick coils [m]}$$

It is useful to mention that the volume densities  $j_1$  and  $j_2$  correspond to a current  $I = I_1 = I_2$  that equals 1 A. We represent in Fig. 2 the axial force exerted between the two coils versus the axial distance  $d$  between them. When  $d = 0$ , the two thick coils are in contact. We have also presented the numerical results of our analytical method and

the filament method in Table 2. Table 2 and Eq. (2) show a very good agreement between the filament method, our amperian current model and the finite element method for calculating the axial force exerted between two thick coils in air. The filament method was employed with  $10 \times 10 \times 10 \times 10$  filaments and the computational cost was 25 s. However, this computational cost can be reduced by employing  $5 \times 5 \times 5 \times 5$  filaments and reach only 1.7 s. The computational cost of our semi-analytical method is 0.18 s.

### 3.2. Second Configuration: Two Thick Coils Having Different Dimensions

The second configuration consists of two thick coils having different dimensions. We use the following parameters:

$$N_1 = 400 \text{ and } N_2 = 800$$

We take the following dimensions:

$$r_1 = 0.1 \text{ m, } r_2 = 0.2 \text{ m, } r_3 = 0.3 \text{ m, } r_4 = 0.4 \text{ m, } z_2 - z_1 = 0.2 \text{ m, } z_4 - z_3 = 0.4 \text{ m, } j_1 = j_2 = 20000 \text{ A/m}^2, d = \text{axial distance between the two thick coils [m].}$$

It is useful to mention that the volume densities  $j_1$  and  $j_2$  correspond to a current  $I = I_1 = I_2$  that equals 1 A.

We represent in Fig. 3 the axial force between two thick coils having different dimensions versus the axial displacement  $d$  and in Table 2 the numerical results in some points. Table 3 and Fig. 3

**Table 2.** Comparison between our analytical approach, the filament method and the finite element method for calculating the axial force (mN) exerted between two thick coils having the same dimensions.

| d [m] | Filament method | amperian current model | Flux 3D |
|-------|-----------------|------------------------|---------|
| 0     | 185.35236819    | 185.1589056            |         |
| 0.01  | 128.17153945    | 128.04563716           | 128     |
| 0.02  | 94.85815069     | 94.75916322            | 95      |
| 0.03  | 73.13895302     | 73.05562878            | 72      |
| 0.04  | 57.93815379     | 57.865606359           | 58      |
| 0.05  | 46.77311227     | 46.708817766           | 47      |
| 0.1   | 18.79270092     | 18.7547813112          | 17      |
| 0.2   | 4.45130774      | 4.4378405952           | 4       |
| 0.5   | 0.26663880      | 0.26555243641          |         |

show that the three methods presented in this paper are in excellent agreement. Nevertheless, our semi-analytical approach has a lower computational cost than the finite element method or the filament method.

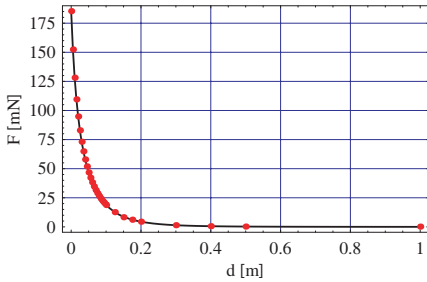

**Figure 2.** Representation of the axial force exerted between two thick coils versus the axial distance  $d = z_3 - z_2$ . We take the following dimensions:  $r_1 = r_3 = 0.0875$  m,  $r_2 = r_4 = 0.1125$  m,  $z_2 - z_1 = z_4 - z_3 = 0.025$  m,  $j_1 = j_2 = 320000$  A/m<sup>2</sup>. Line = our analytical method, Points = Filament method.

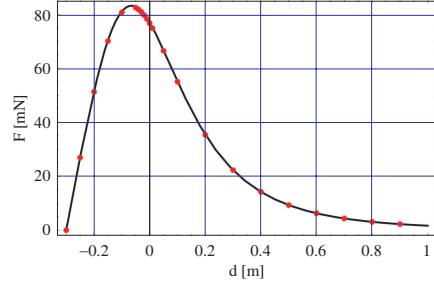

**Figure 3.** Representation of the axial force exerted between two toroidal conductors versus the axial distance  $d$ . We take the following dimensions:  $r_1 = r_3 = 0.0875$  m,  $r_2 = r_4 = 0.1125$  m,  $z_2 - z_1 = z_4 - z_3 = 0.025$  m,  $j_1 = j_2 = 320000$  A/m<sup>2</sup>. Line = our analytical method, Points = filament method.

**Table 3.** Comparison between our analytical approach, the filament method and the finite element method for calculating the axial force (mN) exerted between two thick coils having different dimensions.  $r_1 = 0.1$  m,  $r_2 = 0.2$  m,  $r_3 = 0.3$  m,  $r_4 = 0.4$  m,  $z_2 - z_1 = 0.2$  m,  $z_4 - z_3 = 0.4$  m,  $j_1 = j_2 = 20000$  A/m<sup>2</sup>.

| d [m] | Filament method    | amperian current model | Flux 3D |
|-------|--------------------|------------------------|---------|
|       | <b>5 filaments</b> |                        |         |
| -0.3  | 0                  | 0                      | 0       |
| -0.15 | 70.1056457641      | 70.401487264358        | 70      |
| 0     | 76.7078644327      | 77.0031431689693       | 78      |
| +0.05 | 66.487894642       | 66.7305538188          | 67      |
| +0.3  | 22.2685946360      | 22.2794952389          | 21      |
| +1    | 1.678574304037     | 1.67154193012364       |         |
| +5.0  | 0.006895024572     | 0.0068086780910152     |         |



#### 4. MUTUAL INDUCTANCE OF TWO THICK COILS

Let us first consider the expression of the axial magnetic field produced by the lower thick coil. By considering the number of loops of each thick coil, the axial component of the magnetic field created by the lower coil is expressed as follows:

$$H_z(\tilde{r}, \tilde{z}) = \frac{N_1 I_1}{4\pi S_1} \int_{r_1}^{r_2} \int_{\theta_1}^{\theta_2} \int_{z_1}^{z_2} \left\{ \frac{(\tilde{r} - \tilde{r} \cos(\tilde{\theta})) \tilde{r} d\tilde{r} d\tilde{\theta} d\tilde{z}}{(\tilde{r}^2 + \tilde{r}^2 - 2\tilde{r}\tilde{r} \cos(\tilde{\theta}) + (\tilde{z} - \tilde{z})^2)^{\frac{3}{2}}} \right\} \quad (12)$$

It is emphasized here that the calculation of the force requires the knowledge of the radial component created by the lower thick coil whereas the calculation of the mutual inductance requires the knowledge of the magnetic field axial component created by this lower thick coil.

The flux across one elementary loop of the second thick coil whose radius is  $\mathbf{r}$  is expressed as follows:

$$\varphi = \int_0^{2\pi} \int_0^{\mathbf{r}} H_z(\tilde{r}, \tilde{z}) \tilde{r} d\tilde{\theta} \quad (13)$$

By using the Stoke's Theorem, we can write that:

$$\varphi = \int_0^{2\pi} \int_0^{\mathbf{r}} \left\{ \mu_0 \nabla \times \vec{A} \right\}_{\theta} \tilde{r} d\tilde{\theta} \quad (14)$$

where  $\vec{A}$  is the vector potential created by the lower thick coil. The previous relation can be transformed as follows:

$$\varphi(\mathbf{r}, \tilde{z}) = 2\pi\mu_0 \{A_{\theta}(\mathbf{r}, \tilde{z})\} \quad (15)$$

We obtain:

$$\varphi(\mathbf{r}, \tilde{z}) = \frac{\mu_0 N_1 I_1}{2S_1} \left\{ \int_{r_1}^{r_2} \int_{\theta_1}^{\theta_2} \int_{z_1}^{z_2} \frac{\cos(\tilde{\theta}) \tilde{r} \mathbf{r} d\tilde{r} d\tilde{\theta} d\tilde{z}}{\sqrt{\tilde{r}^2 + \mathbf{r} - 2\tilde{r}\mathbf{r} \cos(\tilde{\theta}) + (\tilde{z} - \tilde{z})^2}} \right\} \quad (16)$$

The total magnetic flux across the second thick coil is given as follows:

$$\phi = \frac{\mu_0 N_1 N_2 I_1}{2S_1 S_2} \int_{r_3}^{r_4} \int_{z_3}^{z_4} \left\{ \int_{r_1}^{r_2} \int_{\theta_1}^{\theta_2} \int_{z_1}^{z_2} \frac{\cos(\tilde{\theta}) \tilde{r} \mathbf{r} d\tilde{r} d\tilde{\theta} d\tilde{z}}{\sqrt{\tilde{r}^2 + \mathbf{r} - 2\tilde{r}\mathbf{r} \cos(\tilde{\theta}) + (\tilde{z} - \tilde{z})^2}} \right\} d\mathbf{r} d\tilde{z} \quad (17)$$

The mutual inductance can be deduced from the previous expression as follows:

$$M = \frac{\phi}{I_1} = \frac{\mu_0 N_1 N_2}{2S_1 S_2} \int_{r_3}^{r_4} \int_{z_3}^{z_4} \left\{ \int_{r_1}^{r_2} \int_{\theta_1}^{\theta_2} \int_{z_1}^{z_2} \frac{\cos(\tilde{\theta}) \tilde{r} \mathbf{r} d\tilde{r} d\tilde{\theta} d\tilde{z}}{\sqrt{\tilde{r}^2 + \mathbf{r} - 2\tilde{r}\mathbf{r} \cos(\tilde{\theta}) + (\tilde{z} - z)^2}} \right\} d\mathbf{r} d\tilde{z} \quad (18)$$

After integrating with respect to  $\mathbf{r}$ ,  $\tilde{z}$  and  $\tilde{\theta}$ , we obtain a semi-analytical expression based on only two numerical integrations:

$$M = \frac{\mu_0 N_1 N_2}{8 S_1 S_2} \int_0^{2\pi} \int_{r_3}^{r_4} \sum_{i=1}^2 (-1)^{(i)} \sum_{j,k=3}^4 (-1)^{(j+k)} r f(r_i, z_j, z_k, \cos(\theta)) dr d\theta \quad (19)$$

with

$$\begin{aligned} f(r_i, z_j, z_k, x) = & \frac{2}{3} (2r_i^2 - r_i r x + r^2(2 - 3x^2) - \epsilon(z_j - z_k)^2) \\ & - 2r^2(z_j - z_k) \ln[z_j - z_k + \epsilon] \\ & + r_i^2(z_j - z_k) + 2r_i r x(z_j - z_k) \\ & - 4r x \sqrt{r^2(-\vartheta^2)}(z_j - z_k) \arctan \left[ \frac{r_i - r x}{r^2(1 - x^2)} \right] \\ & + r^2(2x^2 - 1)(z_j - z_k) \ln[r_i^2 + r^2 - 2r_i r x] \\ & - 2r x (r^2 \vartheta^2 + (z_j - z_k)^2) \ln[r_i - r x + \epsilon] \\ & + \frac{r^2}{\vartheta} (2x - 2x^3 - \vartheta + 2x^2 \vartheta) (z_j - z_k) \ln[A_1] \\ & + \frac{r^2}{\vartheta} (-2x + 2x^3 - \vartheta + 2x^2 \vartheta) (z_j - z_k) \ln[A_2] \end{aligned}$$

where

$$\begin{aligned} A_1 = & \frac{r_i r \vartheta^2 + r^2(+x^2 - 1)(\vartheta - x) - \vartheta(z_j - z_k)(z_j - z_k + \epsilon)}{r^2(+2x - 2x^3 - \vartheta + 2x^2 \vartheta)(+r_i + r(\epsilon - x))(z_j - z_k)^3} \\ A_2 = & \frac{r_i r \vartheta^2 - r^2(-x^2 - 1)(\vartheta + x) - \vartheta(z_j - z_k)(z_j - z_k + \epsilon)}{r^2(-2x - 2x^3 - \vartheta + 2x^2 \vartheta)(-r_i + r(\epsilon + x))(z_j - z_k)^3} \end{aligned} \quad (20)$$

We represent in Fig. 4 the mutual inductance versus the axial distance  $d$  with our analytical method and in Table 4 the numerical results obtained with the finite element method, the approach of Kajikawa

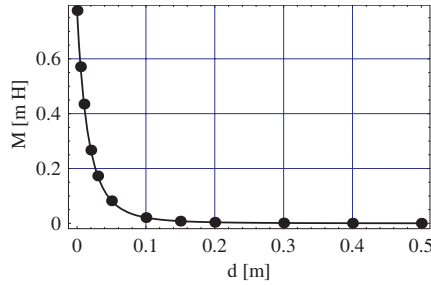

**Figure 4.** Representation of the mutual inductance between two thick coils versus the axial distance  $d$ ;  $r_1 = r_3 = 0.025$  m,  $r_2 = r_4 = 0.03$  m,  $z_2 - z_1 = z_4 - z_3 = 0.025$  m,  $N_1 = N_2 = 200$ .

**Table 4.** Comparison between our analytical model, the approach of Kajikawa [28] and the finite element method for calculating the mutual inductance (mH).  $r_1 = 0.025$  m,  $r_2 = 0.03$  m,  $r_3 = 0.025$  m,  $r_4 = 0.03$  m,  $z_2 - z_1 = 0.025$  m,  $z_4 - z_3 = 0.025$  m,  $N_1 = 200$ ,  $N_2 = 200$ .

| d [m] | Kajikawa | amperian current model |
|-------|----------|------------------------|
| 0     | 0.776    | 0.7753904              |
| 0.005 | 0.571    | 0.5712872              |
| 0.01  | 0.435    | 0.4348317              |
| 0.02  | 0.267    | 0.2667799              |
| 0.03  | 0.173    | 0.1729528              |
| 0.05  | 0.0823   | 0.0823239              |
| 0.1   | 0.021    | 0.0209659              |
| 0.15  | 0.00803  | 0.0080293              |
| 0.2   | 0.00386  | 0.0038579              |
| 0.3   | 0.0013   | 0.00130199             |
| 0.4   | 0.000586 | 0.0005860              |
| 0.5   | 0.000312 | 0.0003119              |

and our analytical approach. Table 4 and Fig. 4 clearly show that all the results are in excellent agreement. This confirms the accuracy of our analytical approach.

## 5. CONCLUSION

We have presented exact semi-analytical expressions of the force exerted between two thick coils carrying uniform current volume densities and of their mutual inductance. For this purpose, we have replaced each thick coil by a toroidal conductor having uniform current volume density. Our expressions are based on two numerical integrations of continuous and derivable functions. Consequently, their computational cost remain very low compared to the finite element method and are also lower than the filament method. This exact expression can be used for calculating the force exerted between two thick coils in air as our results are in excellent agreement with the filament method and the finite element method.

## REFERENCES

1. Costa, E. M. M., "Responses in transformers built with planar coils inner ring coils excited by square waves," *Progress In Electromagnetics Research B*, Vol. 18, 43–58, 2009.
2. Costa, E. M. M., "Planar transformers excited by square waves," *Progress In Electromagnetics Research*, PIER 100, 55–68, 2010.
3. Yang, Z. J. and J. R. Hull, "Magnetic field of cylindrical coils," *Int. J. of Applied Electromagnetics and Mechanics*, Vol. 10, No. 4, 351–367, 1999.
4. Grover, F. W., *Inductance Calculations*, Dover, New York, 1964.
5. Kamon, M., M. J. Tsuk, and J. White, "Fast-henry: A multiple-accelerated 3D inductance extraction program," *IEEE Trans. Microwave Theory Tech.*, Vol. 42, 1750–1758, 1994.
6. Yu, D. and K. S. Han, "Self-inductance of air-core circular coils with rectangular cross section," *IEEE Trans. Magn.*, Vol. 23, No. 6, 3916–3921, 1987.
7. Fawzi, T. H. and P. E. Burke, "The accurate computation of self and mutual inductances of circular coils," *IEEE Trans. PAS*, Vol. 97, No. 2, 464–468, 1978.
8. Bunin, A. G. and M. Y. Vinogreev, "A method for calculating the inductance circular rings of rectangular cross section," *Elektromehhanika*, Vol. 2, 77–85, 1985.
9. Koledintseva, M. Y., et al., "Method of edge currents for calculating mutual external inductance in a microstrip structure," *Progress In Electromagnetics Research*, PIER 80, 197–224, 2008.
10. Koledintseva, M. Y., et al., "Mutual external inductance in

- stripline structures,” *Progress In Electromagnetics Research*, PIER 80, 349–368, 2008.
11. Babic, S. I. and C. Akyel, “Calculating mutual inductance between circular coils with inclined axes in air,” *IEEE Trans. Magn.*, Vol. 44, No. 7, 1743–1750, 2008.
  12. Babic, S. I. and C. Akyel, “Magnetic force calculation between thin coaxial circular coils in air,” *IEEE Trans. Magn.*, Vol. 44, No. 4, 445–452, 2008.
  13. Conway, J., “Inductance calculations for noncoaxial coils using bessel functions,” *IEEE Trans. Magn.*, Vol. 43, No. 3, 1023–1034, 2007.
  14. Ravaud, R. and G. Lemarquand, “Comparison of the coulombian and amperian current models for calculating the magnetic field produced by arc-shaped permanent magnets radially magnetized,” *Progress In Electromagnetics Research*, PIER 95, 309–327, 2009.
  15. Conway, J., “Noncoaxial inductance calculations without the vector potential for axisymmetric coils and planar coils,” *IEEE Trans. Magn.*, Vol. 44, No. 4, 453–462, 2008.
  16. Selvaggi, J. P., et al., “Computation of the external magnetic field, near-field or far-field from a circular cylindrical magnetic source using toroidal functions,” *IEEE Trans. Magn.*, Vol. 43, No. 4, 1153–1156, 2007.
  17. Blache, C. and G. Lemarquand, “New structures for linear displacement sensor with high magnetic field gradient,” *IEEE Trans. Magn.*, Vol. 28, No. 5, 2196–2198, 1992.
  18. Ravaud, R., et al., “Ironless loudspeakers with ferrofluid seals,” *Archives of Acoustics*, Vol. 33, No. 4S, 3–10, 2008.
  19. Lemarquand, G. and V. Lemarquand, “Annular magnet position sensor,” *IEEE Trans. Magn.*, Vol. 26, No. 5, 2041–2043, 1990.
  20. Ravaud, R., G. Lemarquand, and V. Lemarquand, “Force and stiffness of passive magnetic bearings using permanent magnets. Part 1: Axial magnetization,” *IEEE Trans. Magn.*, Vol. 45, No. 7, 2996–3002, 2009.
  21. Ravaud, R., G. Lemarquand, and V. Lemarquand, “Force and stiffness of passive magnetic bearings using permanent magnets. Part 2: Radial magnetization,” *IEEE Trans. Magn.*, Vol. 45, No. 9, 3334–3342, 2009.
  22. Ravaud, R. and G. Lemarquand, “Modelling an ironless loudspeaker by using three-dimensional analytical approaches,” *Progress In Electromagnetics Research*, PIER 91, 53–68, 2009.
  23. Furlani, E. P., “Formulas for the force and torque of axial

- couplings,” *IEEE Trans. Magn.*, Vol. 29, No. 5, 2295–2301, 1993.
24. Kim, K., et al., “Restoring force between two noncoaxial circular coils,” *IEEE Trans. Magn.*, Vol. 32, No. 32, 478–484, 1996.
  25. Lang, M., “Fast calculation method for the forces and stiffnesses of permanent-magnet bearings,” *8th International Symposium on Magnetic Bearing*, 533–537, 2002.
  26. Azzerboni, B., E. Cardelli, and A. Tellini, “Computation of the magnetic field in massive conductor systems,” *IEEE Trans. on Magn.*, Vol. 25, No. 6, 4462–4473, 1989.
  27. Kajikawa, K. and K. Kaiho, “Usable ranges of some expressions for calculation of the self inductance of a circular coil of rectangular cross section,” *Cryogenic Engineering*, Vol. 30, No. 7, 324–332, 1995.
  28. <http://www.sc.kyushu-u.ac.jp/~kajikawa>.