

# Myoplasmic Free Calcium Concentration Reached during the Twitch of an Intact Isolated Cardiac Cell and during Calcium-induced Release of Calcium from the Sarcoplasmic Reticulum of a Skinned Cardiac Cell from the Adult Rat or Rabbit Ventricle

ALEXANDRE FABIATO

From the Department of Physiology, Medical College of Virginia, Richmond, Virginia 23298

**ABSTRACT** Intact cardiac cells from the adult rat or rabbit ventricle were isolated by enzymatic digestion with a progressive increase of the [free  $\text{Ca}^{2+}$ ] in the solution. These cells were electrically stimulated in the presence of 2.50 mM free  $\text{Ca}^{2+}$ , and a twitch of maximum amplitude was elicited by the positive inotropic interventions that were found to be optimum. Then the cells were chemically skinned, and the maximum tension induced by a saturating [free  $\text{Ca}^{2+}$ ] was used as a reference to express the tension developed during the twitch of the intact cells. The myoplasmic [free  $\text{Ca}^{2+}$ ] reached during the twitch was inferred from the tension-pCa curve. In mechanically skinned cells of the same animal species, the myoplasmic [free  $\text{Ca}^{2+}$ ] reached during  $\text{Ca}^{2+}$ -induced release of  $\text{Ca}^{2+}$  from the sarcoplasmic reticulum (SR) was inferred by two methods using (a) the tension-pCa curve and (b) a direct calibration of the transients of aequorin bioluminescence. The induction of a maximum  $\text{Ca}^{2+}$  release from the SR required a larger  $\text{Ca}^{2+}$  preload of the SR and a higher [free  $\text{Ca}^{2+}$ ] trigger in the rabbit than in the rat skinned cells. However, the results obtained with the two methods of inference of the myoplasmic [free  $\text{Ca}^{2+}$ ] suggest that in both animal species a maximum myoplasmic [free  $\text{Ca}^{2+}$ ] of pCa  $\sim$ 5.40 was reached during both the optimum  $\text{Ca}^{2+}$ -induced release of  $\text{Ca}^{2+}$  from the SR of the skinned cells and the optimum twitch of the intact cells. This was much lower than the [free  $\text{Ca}^{2+}$ ] necessary for the full activation of the myofilaments (pCa  $\sim$ 4.90).

## INTRODUCTION

The aim of this study is to test whether the contraction of the intact mammalian cardiac cell is limited by the maximum tension that the myofila-

ments can develop when they are fully activated with  $\text{Ca}^{2+}$  or by the amount of  $\text{Ca}^{2+}$  that the sarcoplasmic reticulum (SR) can accumulate and release. In the process of answering this question, this article also reports a quantitative description of the tension developed by isolated adult mammalian cardiac cells. Until now, only a brief report and an abstract have been published on this subject (Brady et al., 1979; Fabiato and Fabiato, 1979*a*). Finally, this study contains the first description of transients of aequorin bioluminescence in a fragment of a single cardiac cell from which the sarcolemma has been removed by microdissection (skinned cardiac cell). Previously, aequorin transients have only been reported in multicellular preparations of cardiac muscle (Allen and Blinks, 1978; Wier, 1980).

In the intact cardiac muscle, the contractile response (twitch) seems to saturate at a maximum level during strong inotropic interventions such as paired-pulse stimulation (Fisher et al., 1967). Then, additional inotropic interventions do not produce a further increase of the contraction. This could be caused by a saturation of the myofilaments by  $\text{Ca}^{2+}$ . Most investigators use this working hypothesis (e.g., see Brutsaert et al. [1978], p. 477). On the other hand, the phasic contraction elicited by  $\text{Ca}^{2+}$ -induced release of  $\text{Ca}^{2+}$  from the SR of a skinned cardiac cell is far from reaching the full activation of the myofilaments (Fabiato and Fabiato, 1975*a* and *b*). Thus, if  $\text{Ca}^{2+}$ -induced release of  $\text{Ca}^{2+}$  from the SR is the mechanism of excitation-contraction coupling in the mammalian heart, the amplitude of the contraction of the cardiac cell should be limited by the amount of  $\text{Ca}^{2+}$  that the SR can accumulate and release rather than by a saturation of the myofilaments with  $\text{Ca}^{2+}$ .

To test this latter hypothesis, tension will be recorded from an intact isolated cardiac cell under conditions producing maximum and apparently "saturating" positive inotropism. Then the same cell will be chemically skinned by treatment with ethyleneglycol-*bis*( $\beta$ -aminoethyl ether)-*N,N'*-tetraacetic acid (EGTA), and its myofilaments will be fully activated with a saturating [free  $\text{Ca}^{2+}$ ] under conditions where the SR cannot interfere with the myofilament activation. The amplitude of the apparently "saturating" twitch contraction developed by the intact cell will be expressed as a percentage of the tension elicited by maximum  $\text{Ca}^{2+}$  activation of the same cell after chemical skinning. The range of myoplasmic [free  $\text{Ca}^{2+}$ ] reached during the twitch of the intact cells will be inferred from the curve of tension versus pCa ( $-\log_{10}$ [free  $\text{Ca}^{2+}$ ]) of skinned cardiac cells. Thus, the tension developed by the myofilaments will be used as a sensor for measuring changes in myoplasmic [free  $\text{Ca}^{2+}$ ]. Isolated cells rather than multicellular preparations will be used because the multicellular preparations contain a large proportion of nonmuscle cells and cannot be chemically skinned as quickly and completely as the single cells (Fabiato and Fabiato, 1976; McClellan and Winegrad, 1978; Winegrad, 1979*a* and *b*; Miller, 1979; Reuben and Wood, 1979).

The results obtained from the intact cells will be compared with the amplitude of the tension transients elicited by  $\text{Ca}^{2+}$ -induced release of  $\text{Ca}^{2+}$  in mechanically skinned cardiac cells (Fabiato and Fabiato, 1975*a*), expressed as a percentage of the maximum tension elicited by saturation of the myofila-

ments with Ca<sup>2+</sup>. Here again, the tension developed by the myofilaments will be used as a sensor to measure the myoplasmic [free Ca<sup>2+</sup>] reached during the contraction transients. But in addition, the changes of myoplasmic [free Ca<sup>2+</sup>] will be directly monitored by recording the changes in bioluminescence of aequorin, and the myoplasmic [free Ca<sup>2+</sup>] reached during the transient Ca<sup>2+</sup> release will be inferred from the amplitude of the bioluminescence signal according to the method of calibration described by Allen and Blinks (1978 and 1979). For the inference of the myoplasmic [free Ca<sup>2+</sup>] from the tension-pCa curve, there is concern that the response of the myofilaments to the transient, and possibly nonhomogeneous, increase of [free Ca<sup>2+</sup>] resulting from the Ca<sup>2+</sup> release from the SR could be different from their response to the steady-state homogeneous increase of [free Ca<sup>2+</sup>] used for the establishment of the tension-pCa curve. For the inference of the myoplasmic [free Ca<sup>2+</sup>] from the calibration of the aequorin signals, the concern is the possibility that the [free Ca<sup>2+</sup>] could reach a high level in localized areas in the vicinity of the SR resulting in a disproportionate contribution of these areas to the signal because of the stoichiometry of the binding of aequorin to Ca<sup>2+</sup> (Allen and Blinks, 1979). Accordingly, these two different methods for measuring the myoplasmic [free Ca<sup>2+</sup>] will be used comparatively for evaluating the accuracy with which it is possible to define the myoplasmic [free Ca<sup>2+</sup>] reached during the Ca<sup>2+</sup> release from the SR.

Comparative experiments will be done in intact and skinned cells from the adult rat ventricle and from the adult rabbit ventricle because these two species have been shown to represent two extreme cases among the mammalian ventricular tissues for the Ca<sup>2+</sup>-induced release of Ca<sup>2+</sup>. This process is most developed in the rat cells and least developed in the rabbit cells (Fabiato and Fabiato, 1978*a*).

The experiments in intact cardiac cells posed two technical problems: that of obtaining cells that tolerated a physiological [free Ca<sup>2+</sup>], and that of attaching them to microtools for tension recording. Our previous study on this subject (Fabiato and Fabiato, 1972) was done after only three studies on isolated adult cardiac cells (Berry et al., 1970; Bloom, 1970; Vahouny et al., 1970), all of which measured the yield of satisfactory cells by the number of cells contracting cyclically ("beating") in the absence of Ca<sup>2+</sup> added to the solution. We showed that this "beating" in the presence of a low [free Ca<sup>2+</sup>] was, in fact, caused by cycles of Ca<sup>2+</sup> accumulation in, and release from, the SR of cells that had a functionally skinned surface membrane. In contrast, it was possible to separate, through enzymatic digestion, isolated cardiac cells that were not beating in the presence of a low [free Ca<sup>2+</sup>]. According to this criterion, the intact cells were precisely those that were not contracting in the presence of a low [free Ca<sup>2+</sup>] (Fabiato and Fabiato, 1972). The validity of this criterion has been recently confirmed (Brady et al., 1979; Altschuld et al., 1980; Krueger et al., 1980). In these cells, we were able to demonstrate that the membrane was partly intact inasmuch as some action potentials could be recorded (Fabiato and Fabiato, 1972). Several groups have recently reported action potentials from isolated adult cardiac cells of larger amplitude that persisted for a longer time than ours, which were the first ones ever reported

(Lee et al., 1979; Powell et al., 1980; Isenberg and Klöckner, 1980). Some of these preparations, however, were in fact pluricellular, e.g., those used by Lee et al., had a diameter of  $\leq 50 \mu\text{m}$  (15–25  $\mu\text{m}$  radius).

It has been observed that a major factor for increasing the tolerance to  $\text{Ca}^{2+}$  of the cell is that the [free  $\text{Ca}^{2+}$ ] in the solution bathing the cell be increased progressively to favor a decrease of permeability of the surface membrane and a healing over of the intercalated disks (Fabiato and Fabiato, 1972). However, the implications of this observation were not fully used in the previous study. They are used, in contrast, in the present study, and this results in isolated cardiac cells tolerating a [free  $\text{Ca}^{2+}$ ] higher than the physiological level. The other technical modifications are a rapid removal of the enzymes, especially trypsin, and the addition of bovine serum albumin, as suggested by Powell and Twist (1976).

In contrast to the skinned cardiac cells in which the myofilaments attach readily to the glass microtools in the presence of a low [free  $\text{Ca}^{2+}$ ] (Fabiato and Fabiato, 1975*a*), the cells with an intact surface membrane do not attach to the glass. The mammalian ventricular cells are much shorter than the frog atrial cells, and consequently are not amenable to the elegant technique for the attachment of frog atrial cells developed by Tarr et al. (1979), who wrapped the ends of a cell around glass microtools coated with poly-L-lysine. Impaling the mammalian cells with a microtool induces an irreversible contracture (Fabiato and Fabiato, 1972). Accordingly, a new technique was developed which consists of recording the tension from an intact cell that is central in a series of three cells attached end-to-end while a contracture is deliberately induced in the two extreme cells to which the microtools are attached by impalement. It is also possible to use only two cells and to immobilize one end of the intact cell against the bottom of the perfusion chamber without impaling this cell.

Some preliminary results using this technique have been reported (Fabiato and Fabiato, 1979*a*). The cells obtained in this preliminary study, however, were not perfectly intact since they were from the rat ventricle and presented a pronounced post-extrasystolic potentiation during a paired-pulse stimulation. Such a potentiation is absent in the intact adult rat ventricular muscle at supraphysiological [free  $\text{Ca}^{2+}$ ] levels (Meijler et al., 1962). This "unphysiological" behavior of the cells was caused by a too-short period of equilibration in the presence of the high [free  $\text{Ca}^{2+}$ ] perfusion solution. Accordingly, these preliminary results are not included in the present study.

The experiments in skinned cardiac cells posed the problem of recording aequorin bioluminescence from a cell fragment that has a volume of 2–4 pl, which is much smaller than any of the preparations from which aequorin bioluminescence has been recorded previously (Ridgway and Ashley, 1967; Blinks et al., 1976).

#### METHODS

##### *Enzymatic Isolation of, and Tension Recording from, Intact Adult Cardiac Cells*

The same technique was used for the 180–200-g adult rats and the 2–3-kg adult rabbits. After the animal was killed by a blow on the head followed by decapitation,

the heart was removed and placed in a Ca<sup>2+</sup>-free solution containing 140 mM NaCl, 5 mM KCl, 1 mM MgCl<sub>2</sub>, 7 mM glucose, 10 mM *N*-tris(hydroxymethyl)methyl-2-aminoethane sulfonic acid (TES). The pH was 7.40 and the solution was maintained at ~2°C on ice. Subsequently, the pH was readjusted to 7.40 after each change of temperature.

Ventricular tissue was minced with a razor blade into fragments ~2 × 2 × 1 mm. The total weight of muscle tissue used was 50–70 mg. The fragments were washed in the same Ca<sup>2+</sup>-free solution as previously used, but at 22°C. The fragments were then incubated at 36 ± 0.5°C in a Dubnoff metabolic incubator-shaker (Precision Scientific Co., Chicago, Ill.) in 3 ml of the same solution as previously but with the addition of 0.1% trypsin (1:250; Difco Laboratories, Detroit, Mich.), 0.1% collagenase (188 U/mg; Worthington Biochemical Corp., Freehold, N. J.), and 1 mg/ml bovine serum albumin that was free of fatty acids (A7511; Sigma Chemical Co., St. Louis, Mo.). No calcium was added, but 0.05–0.07 mM total calcium was measured by atomic absorption, mostly from the calcium contained in the enzymes.

After 30 min of shaking at 30 cycles/min, the supernatant fluid was removed and replaced by 3 ml of the same solution with no trypsin but still containing 0.1% collagenase. After a new 30-min period of shaking, the supernatant fluid was again removed and replaced by a solution of the same composition but with only 0.05% collagenase plus 0.05 mM total calcium added. This was followed by 30 min of shaking with 0.025% collagenase and 0.1 mM total calcium. Then the collagenase was deleted and the preparation was submitted to three additional 30-min shaking periods with increasing concentrations of added calcium: 0.3 mM, 0.5 mM, and 1.0 mM total calcium, respectively.

After this last 30-min period of shaking in the presence of 1.0 mM total calcium, the preparation was observed under the microscope (see Fabiato and Fabiato [1975*a*] for description of the setup). Most of the cells were in contracture (see bottom right of Fig. 1 for an example of such a cell in contracture), either rounded and still or presenting rapid contractions with asynchrony within a single cell, whereas intact cells were tubular with clearly visible sarcomere striations. These intact cells were quiescent. Among these cells, a very small fraction was made of two or three cells attached end-to-end to each other. These were the preparations used for attachment to the microtools for tension recording.

The cells were then superfused in a 0.050-ml perfusion chamber on the temperature-controlled (22°C) microscope stage, in the same solution as the last one used for the incubation and shaking, except that the serum albumin was deleted. At this point, all substances binding significantly to calcium had been removed and the [free Ca<sup>2+</sup>] was equal to the total added calcium. This perfusion medium had a [free Ca<sup>2+</sup>] of 1.0 mM.

In the preparations made of only two cells attached end-to-end, one end of one cell was immobilized against the bottom of the perfusion chamber by applying gentle and progressive pressure on its surface with a glass microtool without impaling the cell. This produced no damage, provided that the pressure was applied very progressively over a period of several minutes. Then the attachment of the microtool connected to the transducer was done in the other cell in which a contracture was induced, through a procedure that will be described below. For the preparations made of three cells attached end-to-end, both the microtool connected to the transducer and the microtool immobilizing the cell were used to impale the two extreme cells in which a contracture was induced.

The contracture was achieved by passing current through a 1.0-μm-tip microelectrode filled with a solution identical to the perfusion solution, including the presence

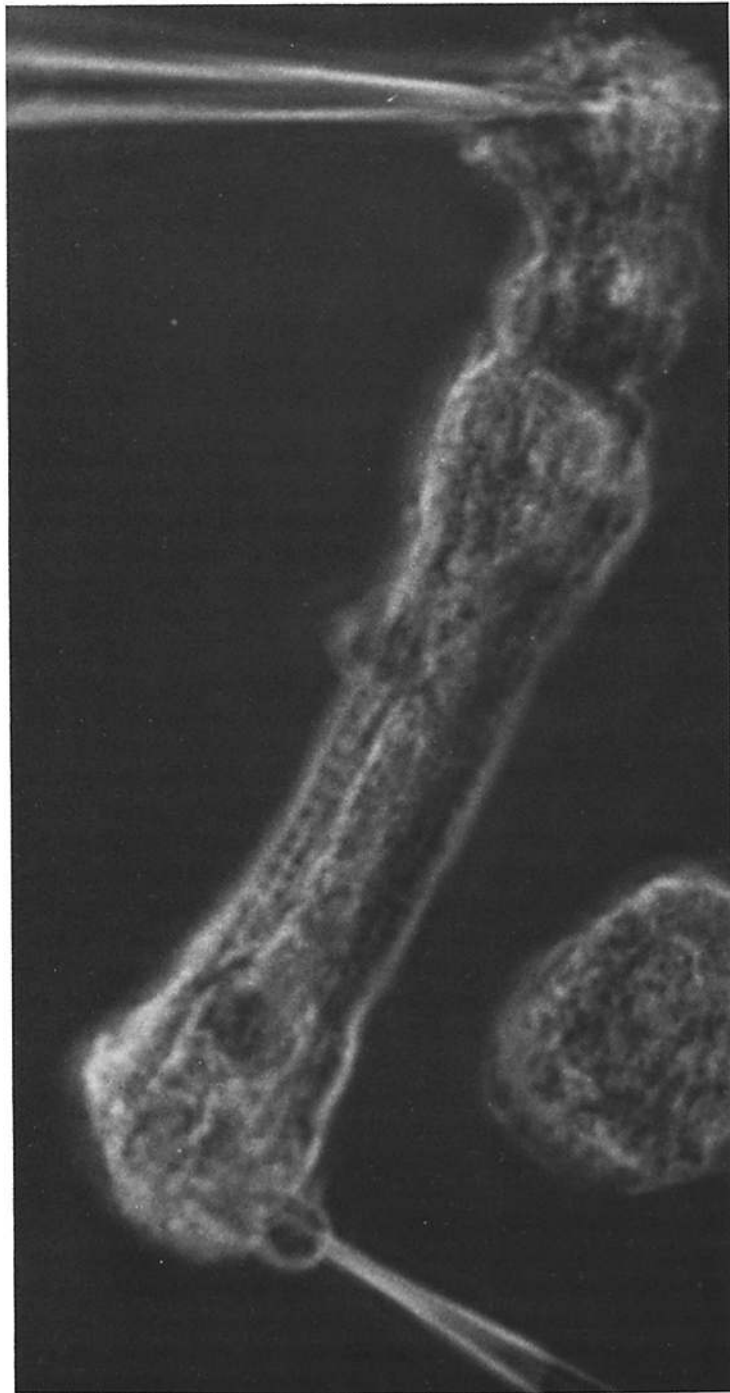

10 μm

of 1.0 mM free Ca<sup>2+</sup>. A current of  $1.0 \times 10^{-7}$ – $1.0 \times 10^{-5}$  A was used. The anode was a platinum wire inserted in the microelectrode, and the cathode was a large platinum electrode in the bath. The duration of the current pulses was variable from 0.1 to 1.0 s. Passing this current resulted in the induction of contractions which propagated as a wave with a speed of 50–100  $\mu\text{m/s}$  from the impaled cell to the other cell, or the two other cells when three cells were used. The current pulses were repeated every 30 s or 1 min, depending on the microscopic observations. As the current pulses were repeated, the propagation to the central cell (or to the only cell that was to remain intact) progressively stopped. This happened after 10–15 min of this experimental procedure. Then, repeating the current pulse and increasing the intensity, sometimes up to  $1.0 \times 10^{-4}$  A, resulted in a complete contracture of the cell impaled with the microelectrode (Fig. 1). This cell became extremely short,  $<1/10$  of its original length, and its structure was obviously grossly modified. After a few more minutes, the tension generated by the cell that remained intact could be recorded.

Success with this procedure of attachment of the cell was achieved in  $<10\%$  of the cases. The major cause of failure was the propagation of the contracture to the cell that was supposed to remain intact. This was avoided by a very progressive induction of the contracture with long waiting periods, which were probably required because of the time needed for the healing-over of the intercalated disk to occur. The contracture was probably caused in part by the calcium iontophoresis, but also by the thermic effect of the high density of current at the tip of the microelectrode.

After its attachment to the transducer, the cell was superfused continuously at a perfusion output of 5.0  $\mu\text{l/min}$  with a solution containing 2.0 mM free Ca<sup>2+</sup> for 30 min and 2.5 mM free Ca<sup>2+</sup> for an additional 30 min. This last 60-min perfusion with increasing [free Ca<sup>2+</sup>] after the attachment of the cell to the transducer was not included in earlier studies (Fabiato and Fabiato, 1979a). This resulted in some properties of the cells that are now considered to be “unphysiological.”

In total, this preparation of a cell with intact surface membrane and its attachment to the transducer required 5–6 h after the death of the animal. The duration of the experiment itself was 1–2 h. No more than one intact cell was ever used during a given experimental day, and many experiments failed with no recording at all.

The electrical stimulation for pacing the cell was applied between a large platinum electrode in the bath as the anode, and a microelectrode (1.0- $\mu\text{m}$  internal tip diameter) filled with the same medium as the perfusion medium and placed 10  $\mu\text{m}$  from the edge of the cell as the cathode. Pulses of  $\sim 1.0 \times 10^{-5}$  A and 50–100 ms were used. As previously shown (Fabiato et al., 1971), intact cells respond by a homogeneous contraction to a cathodal stimulation. This contrasts with the skinned or disrupted cardiac cells in which a contraction is induced only if the stimulation is anodal (Fabiato et al., 1971).

At the end of the experiment on an intact cardiac cell, the cell was submitted to a chemical skinning (Winegrad, 1971, 1979a and b; Miller, 1979; Reuben and Wood, 1979). This was accomplished by a brief (5–20 s) perfusion with a solution containing 10 mM total EGTA with a pCa of 9.00. Then a maximum contraction was induced

---

FIGURE 1. Technique of attachment of an intact cardiac cell from the rabbit ventricle to the microtools for tension recording. In this case, only two cells were used. The end of the lower cell is applied against the bottom of the perfusion chamber by a microtool. This cell is the one that will remain intact and from which tension will be recorded. A contracture is in the process of being induced in the upper cell. The shrinkage of the cell is in progress, rendering the intercalated disk clearly visible. An isolated cell in contracture is also visible.

by perfusion with a solution of pCa 4.50. The details of the composition of the solutions will be described subsequently. In some cases, the perfusion at pCa 4.50 also contained 0.5% of the nonionic detergent polyoxyethylene 20 cetyl ether (Brij 58; Sigma Chemical Co.).

*Calculation of the Composition of the Solutions Used for Skinned Cardiac Cells*

For the experiments using mechanically or chemically skinned cardiac cells, the total concentrations of metals or ligands necessary for obtaining the specified pCa, pMg, pMgATP, and pH at constant ionic strength were calculated with a previously described calculator program (Fabiato and Fabiato, 1979*b*). The stability constants used in the present study are listed in Table I. The absolute stability constants for all

TABLE I  
ABSOLUTE STABILITY CONSTANTS USED FOR CALCULATING THE  
COMPOSITION OF THE SOLUTIONS CONTAINING MULTIPLE METALS AND  
LIGANDS FOR EXPERIMENTS IN CHEMICALLY OR MECHANICALLY SKINNED  
CARDIAC CELLS

Ligand	Cation	Absolute stability constants	Ligand	Cation	Absolute stability constants
		<i>log<sub>10</sub> units</i>			<i>log<sub>10</sub> units</i>
EGTA	H*	log K <sub>1</sub> = 9.58	ATP	H*	log K <sub>1</sub> = 7.07
"	"	log K <sub>2</sub> = 8.97	"	"	log K <sub>2</sub> = 4.17
"	"	log K <sub>3</sub> = 2.80	"	"	log K <sub>3</sub> = 1.00
"	"	log K <sub>4</sub> = 2.12	"	"	log K <sub>4</sub> = 1.00
"	Ca	log K <sub>1</sub> = 10.955	"	Ca	log K <sub>1</sub> = 3.982
"	"	log K <sub>2</sub> = 5.33	"	"	log K <sub>2</sub> = 1.80
"	Mg	log K <sub>1</sub> = 5.21	"	Mg	log K <sub>1</sub> = 4.324
"	"	log K <sub>2</sub> = 3.37	"	"	log K <sub>2</sub> = 2.74
CP	H*	log K <sub>1</sub> = 4.70	"	K	log K <sub>1</sub> = 0.903
"	"	log K <sub>2</sub> = 2.82	"	"	log K <sub>2</sub> = -0.30
"	Ca	log K <sub>1</sub> = 1.15	"	Na	log K <sub>1</sub> = 0.944
"	Mg	log K <sub>2</sub> = 1.30	"	"	log K <sub>2</sub> = 0.602

See Fabiato and Fabiato (1979*b*) for explanations, definitions of the abbreviations, and references to the original studies from which these values have been selected.

\* The H stability constants are mixed constants calculated from concentration constants from the literature with correction for an ionic strength of 0.160 M (Martell and Smith, 1974; Harned and Owen, 1958).

the hydrogen-ligand complexes previously compiled (Fabiato and Fabiato, 1979*b*, pp. 476 and 477) have been corrected by increasing the log<sub>10</sub> value by 0.12. This was necessary to transform these concentration constants of the chemical literature into mixed constants, including activity and concentration terms, directly usable in Program 1 of Fabiato and Fabiato (1979*b*). This correction was kindly suggested by R. Y. Tsien (1980; and R. Y. Tsien, personal communication), who found from reading Martell and Smith (1974) that an error had been made in, apparently, the entire physiological literature using equilibria between multiple metals and ligands. The correction of this error takes into account the H<sup>+</sup> activity at an ionic strength of



0.160 M at 22°C with KCl as the major ionic species, which is extrapolated from the data of Harned and Owen (1958, p. 748).

It must be stressed that these corrections modify little the previously used apparent stability constants (Fabiato and Fabiato, 1979*b*). Calculations with Program 3 of Fabiato and Fabiato (1979*b*) for the solutions indicated in Table II, p. 490 of Fabiato and Fabiato (1979*b*) show, for instance, that the solution calculated for pCa 5.50, pMg 2.50, pMgATP 2.50, and pH 7.10 would have, in fact, a pCa of 5.51, a pMg of 2.42, a pMgATP of 2.62, and a pH of 7.10 if the stability constants listed in Table I of the present article had been used. Such small differences would not modify the experimental data significantly. The correspondence to previous data using other stability constants is indicated in Table IV, p. 503 of Fabiato and Fabiato (1979*b*).

In the past, the major problem with respect to the stability constants between multiple metals and ligands was the uncertainty about the apparent stability constant for the Ca-EGTA complex. The choice was between the apparent stability constant measured by Ogawa (1968) and that incorrectly inferred from the results of Schwarzenbach et al. (1957), which was four times larger around neutral pH. Subsequently, Allen and Blinks (1977)<sup>1</sup> obtained an intermediary value, which we adopted (Fabiato and Fabiato 1978*a* and *b*, 1979*a*, *b*, and *c*). Recently, Harafuji and Ogawa (1980) redetermined the Ogawa (1968) stability constant and found it almost identical to that measured by Allen and Blinks (1977).<sup>1</sup> But Harafuji and Ogawa (1980) state that their stability constant is "still half of that calculated from the results of Schwarzenbach et al. (1957)." In fact, Harafuji and Ogawa (1980) made the previously discussed error, and with the appropriate use of the H-EGTA absolute stability constants by Schwarzenbach et al. (1957), the log<sub>10</sub> of the absolute stability constant for the Ca-EGTA complex is calculated to be 10.955 (the value used in this study, Table I) from the results of Allen and Blinks<sup>1</sup> and 10.953 from the results of Harafuji and Ogawa (1980). Both values are very close to the value of 11.00 determined by Schwarzenbach et al. (1957). The corresponding apparent stability constants at pH 7.10 are  $3.976 \times 10^6 \text{ M}^{-1}$  for Allen and Blinks (1977),<sup>1</sup>  $3.958 \times 10^6 \text{ M}^{-1}$  for Harafuji and Ogawa (1980), and  $4.410 \times 10^6 \text{ M}^{-1}$  for Schwarzenbach et al. (1957). These are very small differences that would not significantly affect the data of the present study.

All the solutions for the present study were used at a temperature of 22°C, an ionic strength of 0.160 M, a pMg of 2.50, a pMgATP of 2.50, and a pH adjusted to 7.10 in the presence of 30 mM TES. The major cation was K<sup>+</sup> and the accessory cation was Na<sup>+</sup> (see Fabiato and Fabiato [1979*b*]). The solutions contained 12 mM total creatine phosphate (CP) and 15 U/ml creatine phosphokinase. The value of 2.50 for the pMg had been selected on the basis of indirect information cited in Fabiato and Fabiato (1979*b*). That this value is in the correct range for the myocardial cell has been recently demonstrated directly with Mg<sup>2+</sup>-sensitive electrodes by R. Weingart and P. Hess (personal communication, 1980). The value of 7.10 for the pH is in agreement with several recent studies that include, in addition to the references given in Fabiato and Fabiato (1979*b*), a recent article by De Hemptinne (1980). Most previous results from skinned cardiac cells have been obtained at a higher pMg (3.50) and a lower pH (7.00). Decreasing the pMg increases both the [free Ca<sup>2+</sup>] required for Ca<sup>2+</sup>-induced release of Ca<sup>2+</sup> and that required for the activation of the myofilaments, so that the former remains lower than the latter, at least in rat ventricular cells (Fabiato and Fabiato, 1975*b*). Increase of pH has the opposite effect (Fabiato and Fabiato, 1978*b*). Both an increase of pH and a decrease of pMg increase the relative amplitude of the

<sup>1</sup> Allen, D. G., and J. R. Blinks. 1977. Unpublished observations as quoted by Fabiato and Fabiato (1978*b* and 1979*b*).

tension transient caused by  $\text{Ca}^{2+}$  release with respect to the maximum tension developed by the myofilaments (Fabiato and Fabiato, 1975 *b* and 1978 *b*). It will be shown that this renders the  $\text{Ca}^{2+}$ -induced release of  $\text{Ca}^{2+}$  demonstrated in skinned cardiac cells under these conditions of higher pH and lower pMg more likely to be large enough for explaining the amplitude of the twitch of the intact cardiac cell.

*Simultaneous Recording of Tension and of  $\text{Ca}^{2+}$  Transients through the Monitoring of Aequorin Bioluminescence in Skinned Cardiac Cells*

**GENERAL DESCRIPTION OF THE TECHNIQUES** According to a previously described technique (Fabiato and Fabiato, 1975 *a*), single skinned cardiac cells from the rat or rabbit ventricle were prepared by a homogenization followed by a microdissection that will be discussed below.

The same tension transducer and force calibrator were used both for the intact and for the skinned cardiac cells (Fig. 2). The photodiode tension transducer (Fabiato and Fabiato, 1975 *a*) had a compliance of 2  $\mu\text{m}/\text{mg}$ . As mentioned previously (Fabiato and Fabiato, 1978 *c*), the calibration of the transducer was done by a specified current passed through a microammeter. The modified needle of the microammeter applied a force on the microtool used for tension recording at a constant distance from the tip of the microtool, i.e., with a constant lever ratio with respect to the pivot of the transducer. The calibration of the specified current itself was done before the experiment by adjusting the current intensity to match a force applied by a weight through the intermediary of a lever (Fabiato and Fabiato, 1976). In all cases, tension ( $T$ , filtered  $>3$  Hz) and its first derivative ( $dT/dt$ ) were recorded. In addition, the aequorin bioluminescence (calibration: 0.1 nA in the figures) was recorded in the skinned cardiac cells, and the output of the anode of the photomultiplier tube was filtered at  $>5$  Hz.

The technique for the simultaneous recording of tension and aequorin bioluminescence had three major goals: (*a*) to minimize the loss through absorption by the microscope optics of the light generated by bioluminescence, which was accomplished by building a new microscope system, (*b*) to bathe the skinned cell in as little of aequorin-containing solution as possible in order to reduce the resting glow, which was accomplished by transferring the cell into oil and then injecting 2 nl of solution around it, and (*c*) to maintain a constant resting glow, which was accomplished by keeping the aequorin-containing tips of the micropipettes to be used in a given experiment permanently in the field of view of the photomultiplier tube.

The main technical problem was that on one hand, the microdissection and tension recording required high-power optics which absorb a tremendous amount of light, and on the other hand, the loss of light had to be minimized as much possible to permit the recording of aequorin signals from so small a preparation. To solve this problem, a micromanipulator-microscope system was specially built using Nikon optics (Nikon Inc., Instrument Div. EPOI, Garden City, N. Y.), a Nikon vibration-free table, and Leitz micromanipulators (E. Leitz, Inc., Rockleigh, N. J.).

The stage for the microscope and the micromanipulators were attached to the vibration-free table. In contrast, the microscope, including illumination, condenser, objective and eyepieces, and the camera were not attached to the vibration-free table but to a lower table on which was placed a microprocessor-controlled movement, which included two perpendicularly mounted sliding mechanisms (Unislide; Velmex, East Bloomfield, N. Y.) for the X- and Y-axis movements. Both movements could be controlled manually for the microdissection (Fig. 3). This setup could then be used as a microscope with a fixed preparation but mobile optics, i.e., the opposite of the usual

arrangement. The X-axis movement was also controlled by a stepping motor that advanced the microscope system in the X-axis direction by  $3 \mu\text{m}/\text{step}$ . A microprocessor (The Superior Electric Co., Bristol, Conn.) controlled the stepping motor. The precision of the movement was  $\pm$  one-half step. This microprocessor-controlled movement permitted the sliding of the optical system from the microdissection position, where high-power optics were used, to the bioluminescence recording

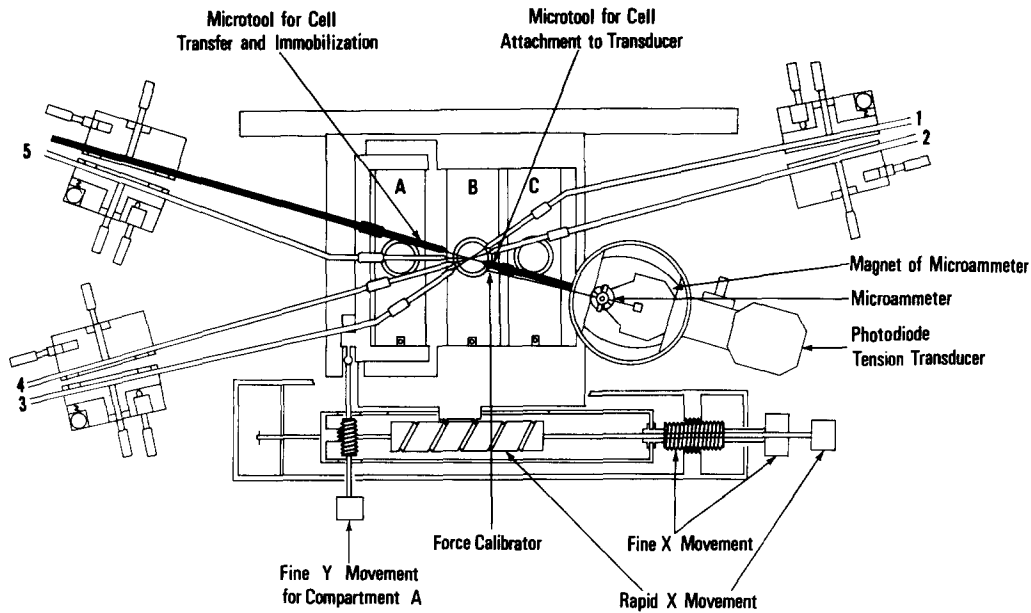

FIGURE 2. Microscope stage, microinjection system, tension transducer, and force calibrator used for simultaneous recording of tension and of aequorin bioluminescence. Chamber *A* was used for the skinning of the cell. Chamber *B* contained ion-free oil and was used for the actual experiment. Chamber *C* contained an aequorin-free solution and was used for setting the microtools and micropipettes. The fine X- and Y-axis movements were used for the microdissection, whereas the rapid X-axis movement was used for the transfer of the skinned cell. Five micropipettes for microinjection (numbers 1-5) are shown, but in some experiments, triple tool holders were used instead of the double tool holders (1, 2) and (3, 4), so that up to seven microinjections could be done. Each micropipette was connected to a system of microinjection and aspiration that was remotely controlled by solenoid-activated valves with adjustable delays and durations. Two of the micropipettes were, in addition, connected to de Fonbrune microsyringes that were manually controlled from inside the light-proof enclosure where the preparation and microscope system were located.

position, where the preparation was at a very short distance from the front of the photomultiplier tube, as will be explained.

A rapid X-axis movement of the microscope stage permitted the dipping of the cell, microtools, and micropipettes, which remained in a fixed X-Y position from one bathing chamber to another among the three contained in the three compartments of this stage (Fig. 2). The first chamber was used for the skinning of the cell, the second

contained ion-free mineral (water-saturated) or silicone oil (it was verified that no significant diffusion of water into the oil occurred during the duration of the experiment), and the third contained a solution with 0.050 mM EGTA, pCa 7.50, pMg 2.50, pMgATP 2.50, pH 7.10, and 0.160 M ionic strength. This third chamber was used for setting the microtools and the micropipettes.

All the micropipettes and microtools were made with Corning (Corning Glass Works, Corning, N. Y.) tubing glass (2 mm outside diameter, 1 mm inside diameter). They were cleaned for 1 h with 70% perchloric acid at 80°C, then with 0.1 mM total EGTA and 30 mM TES at pH 7.10 for 30 min, and finally with deionized water.

The aequorin was kindly given by Dr. Ellis B. Ridgway (Department of Physiology, Medical College of Virginia, Richmond, Va.). It was stored frozen in a solution

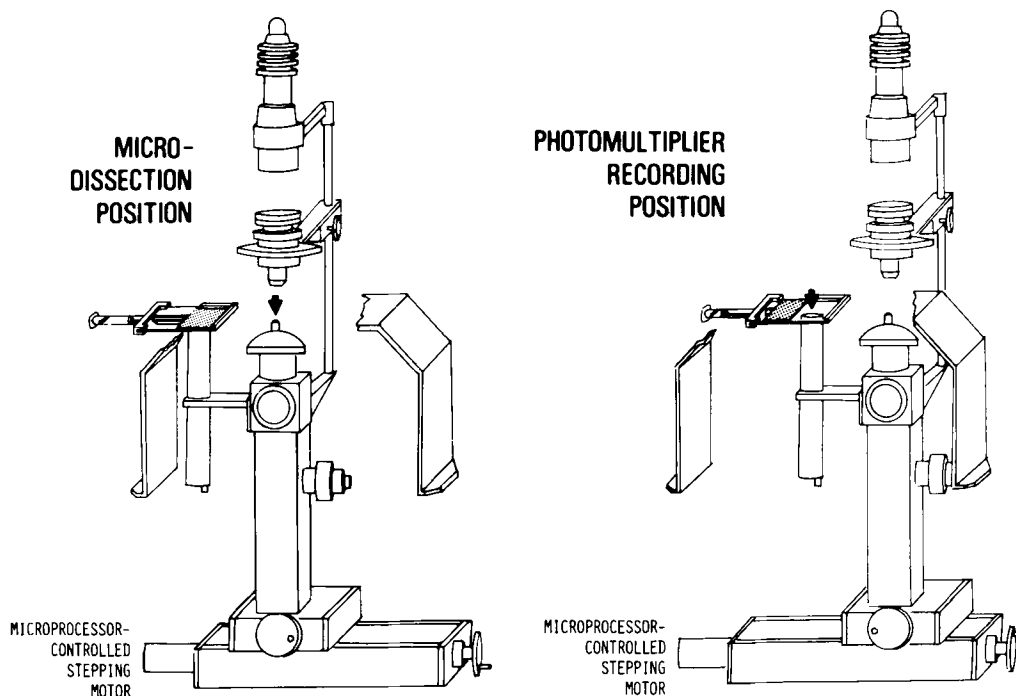

FIGURE 3. Microscope system for simultaneous recording of tension and of aequorin bioluminescence. The arrow indicates the location of the preparation.

containing 0.1 mM EGTA, two times the desired final concentration of KCl, and 30 mM TES. The pH had been adjusted to 7.10 at 22°C. The exact concentration of aequorin was not known. At the time of the experiment, the aequorin-containing solution was defrosted and 0.5  $\mu$ l of this solution was taken. This amount of aequorin-containing solution was mixed with an equal amount of a solution containing no EGTA nor KCl, but all the other constituents specified by the calculator program for the desired experimental solution at a double concentration, except for the TES, which was at 30 mM with pH adjusted to 7.10 at a temperature of 22°C. Accordingly, the solutions used to observe  $\text{Ca}^{2+}$  transients contained 0.050 mM total EGTA with pMg 2.50, pMgATP 2.50, pH 7.10, an ionic strength of 0.160 M, and a variable pCa as indicated in Results. Then the tip of each micropipette was filled with 2 nl of

aequorin-containing solution by vacuum aspiration. The mixing of the two 0.5- $\mu$ l solutions and the filling of the micropipettes were done within a few seconds in a water-saturated atmosphere. The micropipettes were stored at 2°C in a humidified atmosphere and were used within a few hours after their filling.

**DETAILED EXPERIMENTAL PROTOCOL** The first step of the experiment consists of setting all the microtools and aequorin-containing micropipettes in the exact field where they will be used. The chamber that contains solution, but not aequorin, is used for this setting (chamber *C* in Fig. 2). After they are set, the micropipettes and microtools are lifted 0.5 mm and their tips will stay in this position until they are used. Accordingly, the photomultiplier will permanently monitor the bioluminescence of aequorin caused by the various levels of [free Ca<sup>2+</sup>] contained in all the micropipettes. Thus, at the beginning of the experiment, a very large resting glow adds itself to the dark current (0.4 nA with a high voltage of 750 V) of the photomultiplier tube (30-mm photomultiplier tube selected-D144A from EMI Gencom Inc., Plainview, N. Y.). After current-to-voltage conversion with an amplification of 1.0 V/nA, the corresponding baseline voltage is balanced by a counter-bias voltage. This permits the definition of the zero of the recording (see Figs. 8, 9, 12, and 15).

The second step of the experiment consists of skinning the preparation, transferring it into oil, and attaching it to the transducer for tension recording. The method for skinning the preparation has been previously described (Fabiato and Fabiato, 1975*a*). This is done in the chamber (chamber *A* in Fig. 2) located in the stage compartment that has fine X- and Y-axis movements to facilitate the microdissection. The resulting skinned cardiac cell has about one-half the width, one-quarter of the cross-sectional area, and one-sixth to one-fifth of the volume of the original single cardiac cell. The transfer is done by attaching the skinned cell to a microtool in such a way that the cell is protected as it crosses the surface of the solution. This is done by impaling one end of the skinned cell with the microtool and then placing the cell under and parallel to the microtool. The cell attached to the microtool is lifted 2.0 mm above the chamber used for skinning. A rapid movement of the stage permits the bringing of the chamber containing oil under the cell, which is then lowered into the oil (chamber *B* in Fig. 2). The transfer takes  $\sim$ 1.0 s.

After the skinned cell has been transferred into oil, a micropipette is brought close to this cell and 2 nl of aequorin-containing solution at pCa 6.25 is injected in  $\sim$ 0.5 s with a manually controlled microsyringe (de Fonbrune Beaudouin, Paris). This results in the induction of phasic contractions of this unrestrained cell (Fabiato and Fabiato, 1975*a*), which demonstrate that the cell has not been destroyed by the transfer procedure. One end of the skinned cell is attached to a microtool connected to the transducer, and the microtool that has been used for the transfer is now used to immobilize the other end of the cell against the bottom of the chamber (Fig. 2). The tip of the immobilizing microtool goes beyond the cell and is in solid contact with the bottom of the chamber while the immobilized end of the cell is slightly above. The microtool connected to the transducer is oriented perpendicularly to the direction of the length of the cell. Then cyclic tension transients are recorded in the presence of this solution at pCa 6.25 for 30 min. The preparation is discarded if these tension transients do not display a satisfactory consistency in their amplitude and interval. The observation of these cyclic tension transients is not sufficient in itself to demonstrate a Ca<sup>2+</sup>-induced release of Ca<sup>2+</sup> from the SR for reasons that have been indicated previously (Fabiato and Fabiato, 1972, 1975*a*, 1977, and 1978*a* and *b*) and is used only as a criterion for the good condition of the skinned cell and of the appropriateness of one of the aequorin-containing solutions. Aequorin bioluminescence signals are also recorded during these cyclic Ca<sup>2+</sup> releases according to the technique that will be

described later. (See Results for the observations made during this equilibration period.)

A second micropipette containing aequorin and a pCa of 7.50 is then lowered and 2 nl of this solution is injected after the first medium has been re-aspirated into the first micropipette (Fig. 4). In the presence of this solution at pCa 7.50, the preparation presents no phasic contraction. This is the reference solution to which one will return

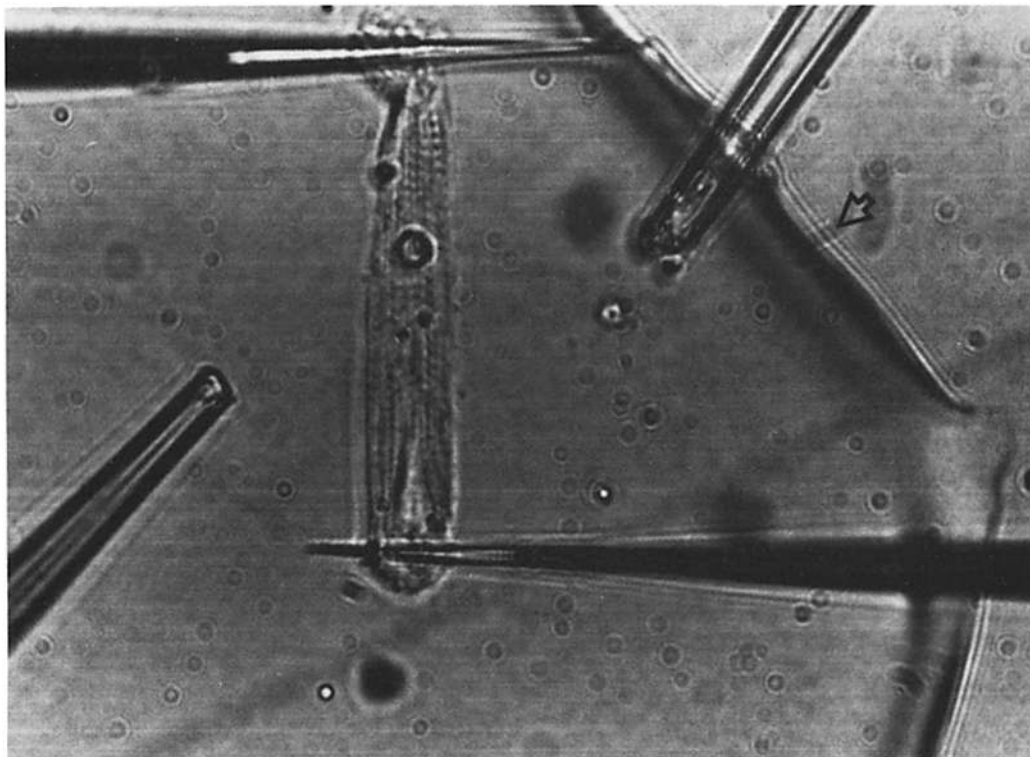

10 $\mu$ m

FIGURE 4. Mechanically skinned cardiac cell from the rat ventricle attached to the microtools for tension recording and bathed in the 2-nl drop of aequorin-containing solution. The interface between the aequorin-containing solution and the oil is indicated by an *arrow*. The lower microtool is attached to the transducer, and the upper one immobilizes the cell. Two microinjection pipettes are in place.

before the application of any solution at various pCa levels. All the subsequent solution changes are not done manually with the de Fonbrune microsyringe but are accomplished by a remotely controlled system with solenoid-activated valves. Thus the solution changes can be done from outside the light-proof enclosure (which is also a Faraday cage) in which the preparation and microscope setup are located. The

duration of the aspiration and the perfusion have been adjusted to 0.1 s each so that the total duration of a solution change is 0.2 s.

The third step of the experiment consists of the actual simultaneous recording of transients of tension and of aequorin bioluminescence caused by Ca<sup>2+</sup>-induced release of Ca<sup>2+</sup> from the SR. After the microdissection and transfer have been done under the high-power optics, the entire microscope is slid away and the front of the photomultiplier tube is brought to a distance of 0.5 mm from the cell without the interposition of any optical components other than the 0.150-mm thick glass bottom of the chamber (Fig. 3). Then complete darkness is achieved, and the ultrathin shutter of the photomultiplier is opened by a pneumatic remote control. The first transient of tension and of aequorin bioluminescence induced by increasing the [free Ca<sup>2+</sup>] from pCa 7.50 to a variable level of lower pCa is recorded. Although the phasic Ca<sup>2+</sup> release will repeat itself if the [free Ca<sup>2+</sup>] is maintained high, only the first transient is considered to be a demonstration of Ca<sup>2+</sup>-induced release of Ca<sup>2+</sup> from the SR for reasons that have been previously stressed (Fabiato and Fabiato, 1972, 1975*a*, 1977, and 1978*a*). When the photomultiplier recording is completed, the microprocessor-controlled system returns the microscope to its exact original position so that observation with microscope can be resumed.

After use, each solution is re-aspirated into the micropipette in which it was originally contained. Accordingly, the 2–4- $\mu$ l skinned cell is surrounded by a several thousand times greater volume of solutions containing aequorin and various levels of [free Ca<sup>2+</sup>]. But these solutions, whether they are still in the micropipettes, or in the bath, or returned to the micropipettes, are permanently in the field of the photomultiplier. Thus this large baseline of light is constant. The only changes of light are those occurring within the cell and they are recorded on top of large background light. The only baseline shift is that related to the consumption of aequorin during the experiment, which is <0.05 nA/h.

The fourth and last step of the experiment consists of terminating it by a calibration using either a maximum tension or an absolute maximum of aequorin bioluminescence. At the end of most experiments, the mechanically skinned cell was submitted to a relaxing solution containing 10 mM EGTA at pMg 2.50, pMgATP 2.50, pH 7.10, ionic strength 0.160 M, and then to a fully activating solution of the same composition, but with a pCa of 4.50. Other mechanically skinned cardiac cells were used for the definition of the tension-pCa relation. They were submitted to various pCa levels in the presence of 10 mM total EGTA, and the same pMg, pMgATP, pH, and ionic strength as in the relaxing solution. The tension was expressed as a percentage of the maximum tension elicited by pCa 4.50.

An additional series of experiments aimed at obtaining an absolute calibration of the aequorin signal was done upon the suggestion of Dr. John R. Blinks, Department of Pharmacology, Mayo Foundation, Rochester, Minn. After the recording of the aequorin bioluminescence transients induced by various levels of [free Ca<sup>2+</sup>] trigger, most of the 2 nl of solution was aspirated so that only the aequorin contained in the skinned cell remained present. Then a solution containing 0.050 mM total EGTA (i.e., the same concentration as used for the induction of Ca<sup>2+</sup> release from the SR), pCa 2.50, pMg 2.50, pMgATP 2.50, pH 7.10, 0.160 M ionic strength, and no aequorin was injected with a manually controlled de Fronbrune microsyringe in ~0.5 s. This resulted in a large bioluminescence signal.

During the large bioluminescence transient, a 6809 microcomputer (Southwest Technical Corp., San Antonio, Tex.) collected the data points every 5 ms and stored them in a buffer. The microcomputer calculated the area under the curve and

displayed it on the recorder at a chart speed of 1 cm/s as a rectangular wave with a height equal to the time constant of the decay of the aequorin bioluminescence (0.8 s) measured in a rapid-mixing chamber by Allen and Blinks (1979, p. 166), assuming that the light decay was purely exponential. The value of the intercept of an exponential with the ordinate axis is equal to the area between the curve and the two axes divided by the time constant. Thus the length of the rectangular wave (see Fig. 12) directly gives the amplitude of the absolute maximum light that would be produced by an instantaneous mixing of an excess  $\text{Ca}^{2+}$  with all the aequorin contained in the skinned cell. This length was used to obtain the ratio between the light produced during a  $\text{Ca}^{2+}$  transient and the absolute maximum light. Then the calibration curve obtained during rapid mixing in a cuvette of aequorin and  $\text{Ca}^{2+}$  (see Fig. 1 of Allen and Blinks [1979]) was used to infer the pCa reached during  $\text{Ca}^{2+}$  release. The composition of the solutions used by Allen and Blinks was very close to that used in the present study: pH lower by 0.1, pMg higher by 0.2, and temperature lower by 1°C. These small differences would not affect the aequorin bioluminescence significantly (see Fig. 2 of Allen and Blinks [1979]; see also Moiescu and Ashley [1977]). Finally, the low [total EGTA] used in the present experiments is unlikely to affect the  $\text{Ca}^{2+}$ -aequorin reaction.

For all the experiments, intact or skinned cardiac cells were stretched to a length at which little resting tension was developed ( $\sim 2.2\text{-}\mu\text{m}$  sarcomere length). This was done to minimize the risk that unloading of a parallel elastic element during the imperfectly isometric tension recording would cause a drop of resting tension, which would have resulted in an underestimate of the active tension (see Fabiato and Fabiato [1978*c*] for rationale). The length and width of the cells were measured at this sarcomere length of  $\sim 2.2\ \mu\text{m}$ .

Adenosine 3':5'-cyclic monophosphate sodium salt (cyclic AMP) and l(-) isoproterenol bitartrate salt were obtained from the Sigma Chemical Co. EGTA was obtained from either Sigma Chemical Co. or Eastman Kodak Co. (Rochester, N. Y.). For each batch, the degree of purity of EGTA (measured by titration by the laboratories of the suppliers) was taken into account in the calculation of the stock solutions (see Fabiato and Fabiato [1979*b*] for details of the technique for making up these solutions).

All the results were expressed as mean  $\pm$  SD, because, in some cases, the SEM would have been too small to be shown graphically. Student's *t* test was used for comparison between data, and differences were judged significant for  $P < 0.05$ .

## RESULTS

### *Intact Cardiac Cells from the Rabbit Ventricle*

A large number of preparations were studied and the effects of many interventions were tested to define the most appropriate conditions for obtaining a twitch of maximum amplitude. Finally, only those preparations in which the most relevant series of experiments had been done under exactly the same conditions were retained. These included a single-pulse stimulation at 12/min, a paired-pulse stimulation at optimum interval, and a single-pulse stimulation and a paired-pulse stimulation in the presence of  $1.0 \times 10^{-6}$  M isoproterenol. Increasing the [free  $\text{Ca}^{2+}$ ] to 8.0 mM increased the amplitude of the twitch, but to a much lesser degree than isoproterenol. Consequently, this intervention was not used for the quantitative analysis. Only nine cells



met these criteria and were retained for statistical analysis. Accordingly,  $n = 9$  for all of the following results. A typical experiment is shown in Fig. 5; some examples of experiments that were not used for statistical analysis are shown in Fig. 6.

At the end of each experiment, the cell was submitted to a chemical skinning so that the maximum Ca<sup>2+</sup>-activated tension could be obtained (Fig. 5 *D*). Preliminary experiments demonstrated that applying a 10-mM EGTA solution at pCa 4.50 with, in addition, 0.5% of the detergent Brij 58 did not result in a further increase of the tension as compared with that developed in the absence of detergent. This was taken as evidence that the remaining sarcolemma had been rendered fully permeable to Ca<sup>2+</sup> by the chemical skinning with EGTA alone. Previous evidence also suggests that this chemical skinning effectively disrupts the surface membrane in single-cell preparations of cardiac and skeletal muscles (Reuben and Wood, 1979; Fabiato and Fabiato, 1976), whereas the sarcolemma remains physically present and has some control on the contraction in multicellular preparations (Winegrad, 1979 *a* and *b*), even if these multicellular preparations are obtained by a homogenization procedure (Fabiato and Fabiato, 1976). The detergent-containing solution, however, caused a disjunction of the intercalated disks within 2 s. Thus, many of the experiments in which the maximum Ca<sup>2+</sup>-activated tension was compared in the presence and in the absence of detergent were lost because of the lack of a clear plateau during the detergent application. The systematic inclusion of a detergent application in the experiments in which twitches had been recorded under various conditions would have resulted in the loss of many of these experiments of very long duration. Accordingly, the application of detergent was not included in the experiments illustrated in Fig. 5 and quantified in Fig. 11. The ~10-s-long plateau obtained with the solution of pCa 4.50 in the absence of detergent permitted the accurate determination of the maximum tension.

The maximum tension developed by the nine cells during full activation after chemical skinning (Fig. 5 *D*), was  $2.52 \pm 0.17$  mg. The length of these cells was  $97 \pm 10$   $\mu\text{m}$  and their width was  $18 \pm 3$   $\mu\text{m}$ . The thickness of a cell, approximately measured by varying the focusing of the objective with a calibrated dial, averaged 12  $\mu\text{m}$ . Assuming that the cell had a rectangular cross section, this cross section averaged  $2.16 \times 10^{-4}$   $\text{mm}^2$  and the maximum tension per cross-sectional area developed by the fully activated cell after chemical skinning averaged 11.67 g/ $\text{mm}^2$ , which is more than the maximum tension per cross-sectional area developed by intact multicellular preparations. The tension per cross-sectional area developed during the twitch before chemical skinning also compared favorably with that developed by the multicellular preparations. This can be easily calculated by comparing the percentages of 11.67 g/ $\text{mm}^2$  that are given subsequently for the twitches of the isolated cells under various conditions with the tension per cross-sectional area developed by the multicellular preparations under similar conditions (e.g., see Bodem and Sonnenblick [1975]).

The control twitch during a regular single-pulse stimulation at 12/min

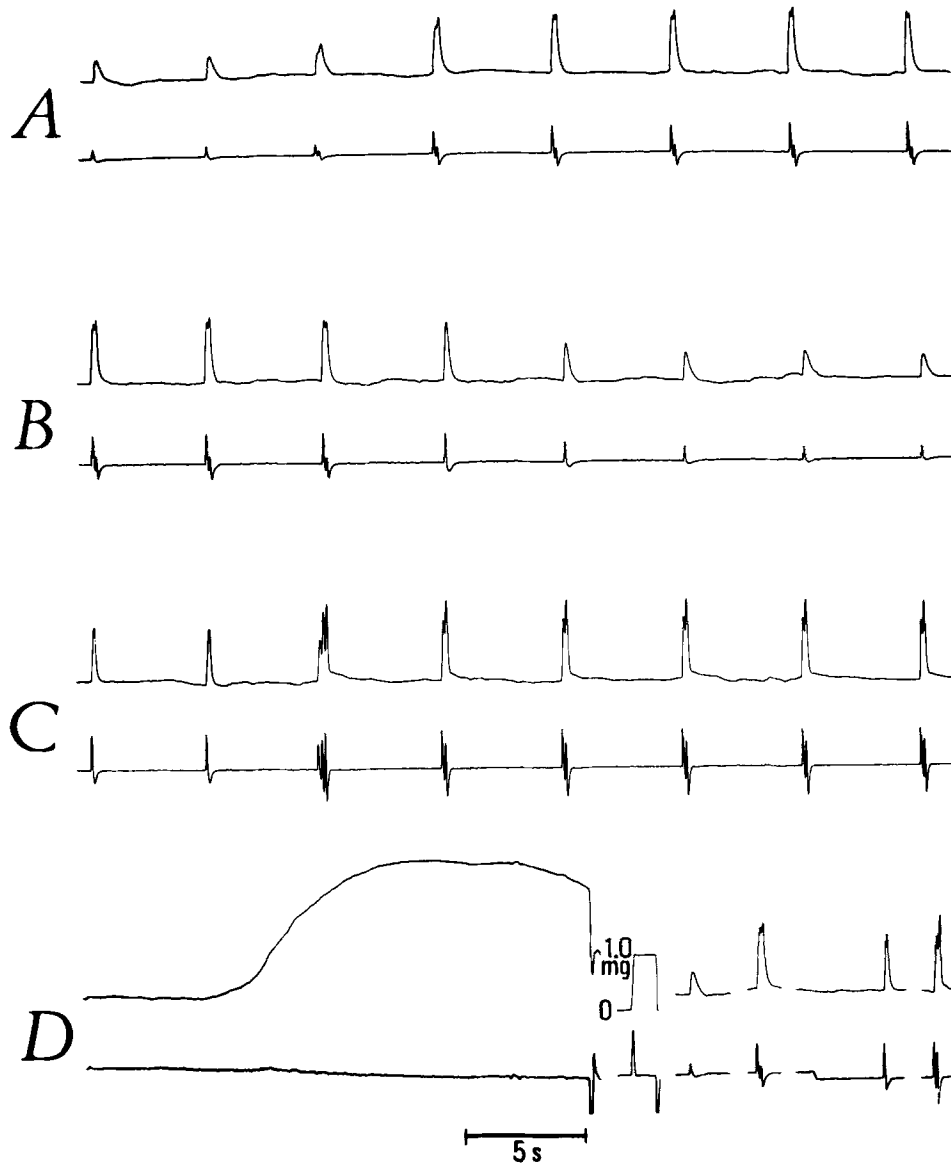

FIGURE 5. Recording of tension (*upper trace*) and of its time derivative (*lower trace*) from an intact isolated cardiac cell from the rabbit ventricle. The stimulation frequency was constant at 12/min. The  $[\text{free Ca}^{2+}]$  was 2.50 mM. All the tracings were obtained from the same cell, which was 99  $\mu\text{m}$  in length and 19  $\mu\text{m}$  in width. (A) Initially, the cell was submitted to a regular single-pulse stimulation. Then a paired-pulse stimulation at optimum interval was induced (*third twitch*). (B) Interruption of the paired-pulse stimulation (*fourth twitch*) and return to the single-pulse stimulation. (C) Initially, a single-pulse stimulation in the presence of  $1.0 \times 10^{-6}$  M isoproterenol, then a paired-pulse stimulation at optimum interval was induced (*third twitch*). (D) Initially, the cell was chemically skinned by perfusion in the presence of 10 mM total EGTA, pCa of 9.00, pMg

developed a tension with respect to the maximum Ca<sup>2+</sup>-activated tension (relative tension) of  $19 \pm 12\%$  (Fig. 5 *A* and *B*; and point A in Fig. 11). The optimum interval for paired-pulse stimulation was that corresponding to the shortest interval at the limit of the refractory period. A slight lengthening of the interval resulted in a small decrease in the amplitude of the potentiated twitch (Fig. 6 *A* and *B* compared with Fig. 5 *A* and *B*). Thus this preparation showed, in common with the multicellular preparations from the rabbit ventricle, an increase of potentiation when the interval was shortened, but it did not present the decrease of the potentiation for extremely short intervals (Koch-Weser and Blinks, 1963). This latter property of the rabbit ventricular muscle is, therefore, probably related to a nonhomogeneity of the response of the cells of these multicellular preparations at intervals close to the refractory period. Paired-pulse stimulation at the optimum interval produced a relative tension of  $48 \pm 11\%$  (Fig. 5 *A* and *B*; and point B in Fig. 11).

The maximum effect of isoproterenol was obtained with a concentration of  $1.0 \times 10^{-6}$  M. Increasing the concentration to  $3.0 \times 10^{-6}$  M produced a rapid spontaneous activity so that the preparation could not be paced at a constant rhythm (Fig. 6 *C*). The relative amplitude of the contraction obtained with  $1.0 \times 10^{-6}$  M isoproterenol at a constant frequency of 12/min was  $44 \pm 12\%$  (Fig. 5 *C*; and point C in Fig. 11). Paired-pulse stimulation in the presence of  $1.0 \times 10^{-6}$  M isoproterenol produced the maximum contraction that could be obtained with this intact preparation: its relative amplitude was  $63 \pm 9\%$  (Fig. 5 *C*; and point D in Fig. 11). Sometimes, extra contractions were induced by the stimulation in the presence of isoproterenol, as shown at the time of the initiation of the paired-pulse stimulation in Fig. 5 *C*.

Finally, this preparation presented a well-developed positive staircase (Fig. 6 *D*).

#### *Intact Cardiac Cells from the Rat Ventricle*

The intact cardiac cells from the rat ventricle presented a pronounced negative staircase (Fig. 7 *A*). Preliminary experiments showed that neither an increase of the [free Ca<sup>2+</sup>] to 8.0 mM nor the addition of  $1.0 \times 10^{-6}$  M isoproterenol resulted in an increase of the amplitude of the twitch or of the maximum rate of tension development with respect to the control twitch during regular

---

2.50, pMgATP 2.50, pH 7.10. Then a full activation was induced by a solution at pCa 4.50. After a plateau of tension of  $\sim 10$  s, the preparation broke by disjunction of the intercalated disk resulting in, at first, a progressive and then an abrupt drop of tension. This is followed by a 1.0-mg calibration produced by the force calibrator. Then individual twitches are shown corresponding to: single-pulse stimulation under control conditions, paired-pulse stimulation with optimum interval, single-pulse stimulation in the presence of  $1.0 \times 10^{-6}$  M isoproterenol, and paired-pulse stimulation in the presence of  $1.0 \times 10^{-6}$  M isoproterenol. The distances between the zero of tension during the calibration, the baseline trace of the tension, and the stable baseline trace of the derivative permit one to follow the level of resting tension in all of the tracings. For this reason it is shown that the derivative trace had been moved downward at the beginning of the experiments in the presence of isoproterenol.

single-pulse stimulation in the presence of 2.50 mM free  $\text{Ca}^{2+}$ . Accordingly, the seven experiments used for statistical analysis included only a single-pulse stimulation at 12/min and a paired-pulse stimulation at the optimum interval, which was the shortest interval possible. As for the rabbit cells, the presence

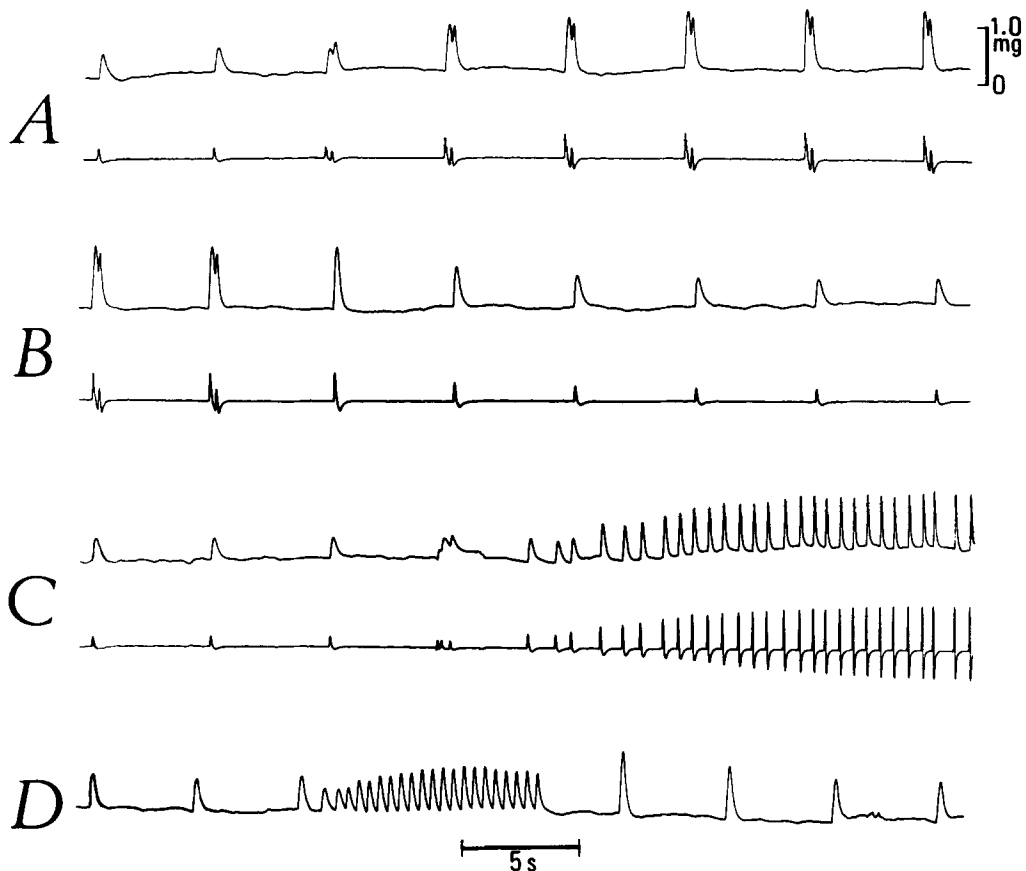

FIGURE 6. Recording of tension and of its first derivative from the same cell as that used for Fig. 4 (*A*, *B*, and *C*) and from another cell from the rabbit ventricle (*D*). These are examples of experiments that were not used for the statistical analysis (Fig. 11). (*A*) Induction of a postextrasystolic potentiation by paired-pulse stimulation (*third twitch*) with an interval slightly greater than optimum. (*B*) Interruption of the paired-pulse stimulation (*third twitch*). (*C*) Induction of a spontaneous activity by  $3.0 \times 10^{-6}$  M isoproterenol applied just before the multicomponent twitch. (*D*) In another cell, positive staircase followed by a post-stimulative potentiation.

of Brij 58 during chemical skinning did not modify the maximum  $\text{Ca}^{2+}$ -activated tension, but no detergent was employed in the experiments used for statistical analysis.

When fully activated with  $\text{Ca}^{2+}$  after chemical skinning, these cells devel-

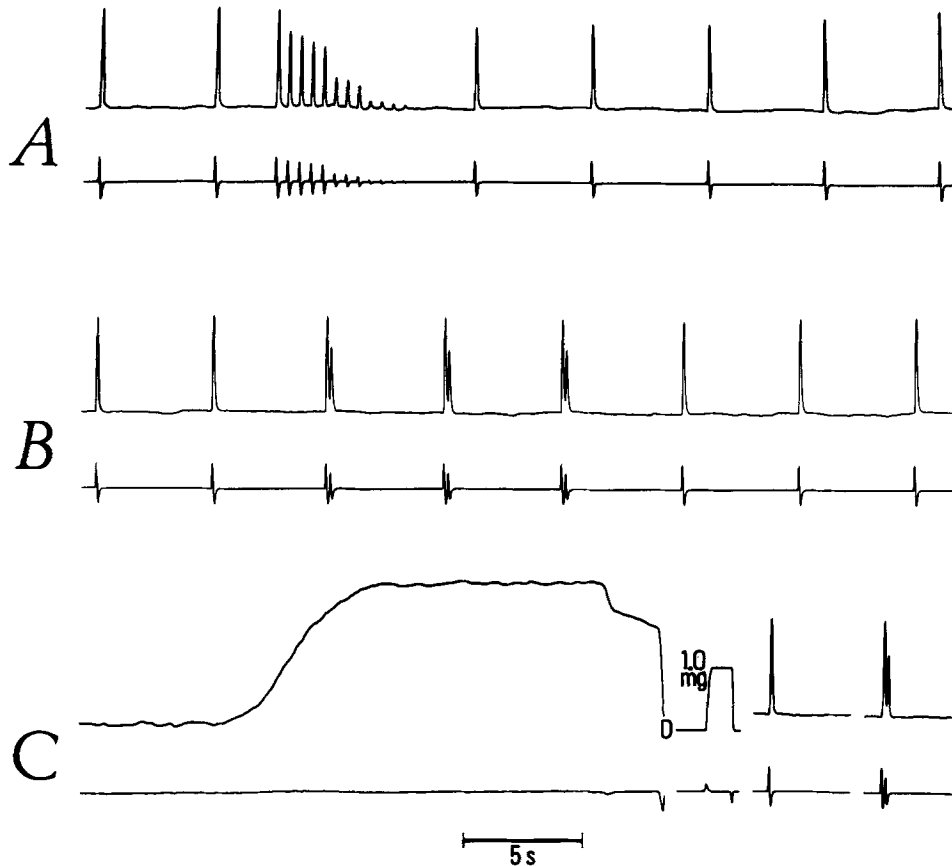

FIGURE 7. Recording of tension (*upper trace*) and of its first derivative (*lower trace*) from an intact isolated cardiac cell from the rat ventricle. The stimulation frequency was 12/min. The  $[free\ Ca^{2+}]$  was 2.50 mM. All the recordings were obtained from the same cell, which was 103  $\mu\text{m}$  long and 17  $\mu\text{m}$  wide. (A) Initially, the cell was submitted to a regular single-pulse stimulation, then the frequency was increased by a factor of 10. This resulted in a negative staircase. A return to the frequency of 12/min resulted in a progressive return of the contraction to its initial amplitude. (B) Initially, the cell was submitted to a regular single-pulse stimulation, then a paired-pulse stimulation was introduced (*third twitch*). (C) Initially, the cell was chemically skinned in the presence of 10 mM total EGTA, pCa 9.00, pMg 2.50, pMgATP 2.50, pH 7.10. Then a solution at pCa 4.50 caused the development of a plateau of maximum tension. The tension drop, in two steps, was caused by the disjunction of the intercalated disk. This is followed by a 1.0-mg calibration and by individual twitches corresponding to single-pulse stimulation and paired-pulse stimulation. As in Fig. 5, these tracings permit one to follow the level of the resting tension throughout the recordings. Note that the gain of the amplifier for the derivative was 2.5 times less than that used in Figs. 5 and 6 for the rabbit ventricular cells.

oped a maximum tension of  $2.45 \pm 0.25$  mg. The seven intact cells had a length of  $93 \pm 8$   $\mu\text{m}$ , a width of  $19 \pm 3$   $\mu\text{m}$ , and a thickness of  $\sim 11$   $\mu\text{m}$ . The estimated cross-sectional area averaged  $2.09 \times 10^{-4}$   $\text{mm}^2$ . Accordingly, these cells developed after chemical skinning a maximum tension per cross-sectional area that averaged  $11.72$   $\text{g}/\text{mm}^2$ , which is higher than the tension per cross-sectional area developed during the maximum twitch of multicellular preparations from the rat ventricle (Henderson et al., 1969; Bodem and Sonnenblick, 1975).

During single-pulse stimulation at 12/min in the presence of 2.50 mM free  $\text{Ca}^{2+}$ , these preparations developed a relative tension of  $71 \pm 8\%$  (Fig. 7A and B; and point A in Fig. 10). The relative tension developed during paired-pulse stimulation was  $64 \pm 7\%$ , which was not significantly smaller than the tension observed during single-pulse stimulation (Fig. 7B; and point B in Fig. 10). The absence of potentiation of the contraction by paired-pulse stimulation is consistent with the findings in multicellular preparations from the rat ventricle in the presence of  $>2.0$  mM free  $\text{Ca}^{2+}$  (Meijler et al., 1962; Henderson et al., 1969; Forester and Mainwood, 1974).

#### *Skinned Cardiac Cells from the Rat Ventricle*

Although the concentration of aequorin contained in the solutions used for the experiments with mechanically skinned cardiac cells was not known, it was certainly much higher than that used in intact muscle cells by others (Ridgway and Ashley, 1967; Blinks et al., 1976). Accordingly, there was concern that this amount of aequorin could bind  $\text{Ca}^{2+}$  significantly with respect to the 0.050 mM total EGTA contained in the solutions. However, this was proven not to be the case: in six mechanically skinned cells, the amplitude of the phasic contractions induced by a pCa of 6.25 was not significantly different in the presence or in the absence of aequorin.

The experiments used for quantitative analysis were done in 10 mechanically skinned cells from the rat ventricle, which were  $9 \pm 2$   $\mu\text{m}$  wide and  $58 \pm 11$   $\mu\text{m}$  long. The thickness of the skinned cells was not measured in these experiments. However, previous experiments (e.g., Fabiato and Fabiato [1975a]), in which the thickness had been measured, showed that the ratio between width and thickness is the same in intact and mechanically skinned cardiac cells. Thus the cross-sectional area of a skinned cardiac cell is about one-quarter of that of an intact cell.

All the microinjection solutions were at pMg 2.50, pMgATP 2.50, pH 7.10, 0.160 M ionic strength, and 22°C temperature. In the presence of 0.050 mM total EGTA, phasic releases of  $\text{Ca}^{2+}$  were induced by increasing, in 0.2 s, the [free  $\text{Ca}^{2+}$ ] in the medium from a pCa of 7.50 (at which no release was observed) to pCa 7.00, 6.75, 6.50, 6.25, and 6.15. The experiment was terminated by increasing the [total EGTA] to 10 mM in the presence of a pCa of first 9.00 and then 4.50. This resulted in the induction of a maximum tension of  $0.610 \pm 0.059$  mg, relative to which the amplitude of the phasic contractions was measured (Fig. 8). This is about one-quarter of the tension developed by an intact cardiac cell, i.e., the same ratio as that of the respective cross-sectional areas. Thus the two types of preparations develop approxi-

mately the same maximum tension per cross-sectional area. The mechanically skinned cells, however, have a swollen myofilament lattice (Fabiato and Fabiato, 1978*c*), which might suggest that their myofilaments develop more tension than those of the intact cells. On the other hand, some of the cellular components removed by mechanical skinning are noncontractile materials, such as superficial mitochondria.

In contrast with results reported in partially skinned skeletal muscle fibers (Endo and Blinks, 1973), no aequorin signals were ever observed in the absence of tension transients. The duration of the aequorin signal was much shorter than that of the contraction transient (Fig. 8). It started before the

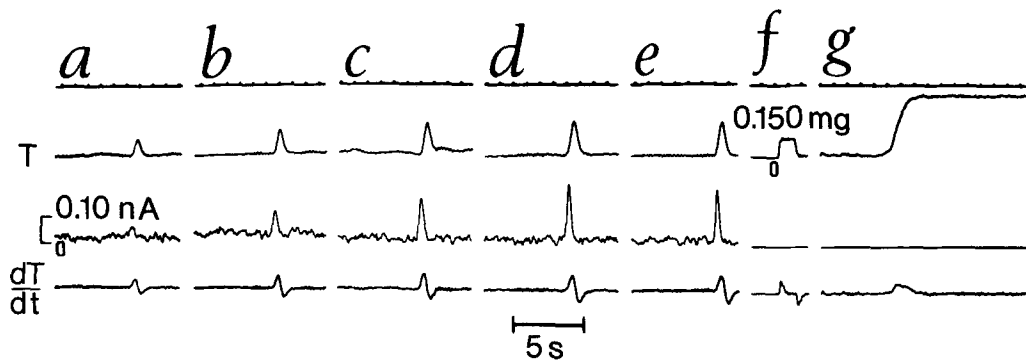

FIGURE 8. Simultaneous recording of tension ( $T$ ), bioluminescence of aequorin (scale: 0.1 nA) and time derivative of the tension ( $dT/dt$ ) in a 9- $\mu\text{m}$  wide, 6- $\mu\text{m}$  long, mechanically skinned cardiac cell from the rat ventricle. The transients of tension and of aequorin bioluminescence were triggered by an increase, in 0.2 s, of the [free  $\text{Ca}^{2+}$ ] in the solution from pCa 7.50 to pCa 7.00 (*a*), 6.75 (*b*), 6.50 (*c*), 6.25 (*d*), and 6.15 (*e*). In these solutions the [total EGTA] was 0.050 mM, pMg 2.50, pMgATP 2.50, pH 7.10, and ionic strength 0.160 M. Then a tension calibration of 0.150 mg was displayed, and without change of calibration, the cell was submitted to a 10-mM total EGTA solution at pCa 9.00 with the same pH, pMg, pMgATP, and ionic strength. Increase of the [free  $\text{Ca}^{2+}$ ] to pCa 4.50 induced a maximum tension, which was used as a reference to measure the submaximal tensions. See Methods for the determination of the zero of the bioluminescence recording.

beginning of the contraction, reached its peak when <10% of the tension transient had developed,  $\sim 0.2$  s before the maximum of the  $dT/dt$ . It returned to zero about at the time when the tension reached its peak.

Increasing the [free  $\text{Ca}^{2+}$ ] used as a trigger in the presence of a constant [total EGTA] of 0.050 mM resulted in an increase of the amplitude of both the tension transient and the aequorin transient. The relative amplitude of the tension transient was  $26 \pm 4\%$  for a pCa trigger of 7.00 (Fig. 8*a*; and point *a* in Fig. 10),  $38 \pm 6\%$  for pCa 6.75 (Fig. 8*b*; and point *b* in Fig. 10),  $49 \pm 8\%$  for pCa 6.50 (Fig. 8*c*; and point *c* in Fig. 10) and  $66 \pm 9\%$  for pCa 6.25 (Fig. 8*d*; and point *d* in Fig. 10). A further increase of [free  $\text{Ca}^{2+}$ ] did not result in further increase of the amplitude of the tension: the relative amplitude of the

tension transient induced by a pCa trigger of 6.15 was  $59 \pm 7\%$  (Fig. 8*e*; and point *e* in Fig. 10), which was not significantly different from the amplitude observed with a pCa trigger of 6.25. No pCa <6.15 was used in this experimental series to avoid too high a resting glow of aequorin bioluminescence. In other experiments in which no aequorin bioluminescence was recorded, it was observed that a pCa trigger of 6.00 induced a phasic tension of  $48 \pm 9\%$  ( $n = 4$ ; not shown in Fig. 10 to avoid superimposition with point *c*), which is significantly less than the maximum phasic tension induced by a pCa trigger of 6.25.

The effect of increasing the [free  $\text{Ca}^{2+}$ ] used as a trigger on the amplitude of the  $\text{Ca}^{2+}$  transients detected by aequorin bioluminescence was qualitatively similar to the effect on the tension transient: increase in amplitude when the [free  $\text{Ca}^{2+}$ ] used as a trigger was increased up to pCa 6.25 (Fig. 8*a-d*), which was the optimum (Fig. 8*e*). Quantitatively, however, this effect was larger on the aequorin transient than on the tension transient. Expressed as a percentage of the transients of bioluminescence corresponding to the maximum  $\text{Ca}^{2+}$  release induced by a pCa trigger of 6.25 (100%), the amplitude of the aequorin transient was  $21 \pm 5\%$  for a pCa trigger of 7.00,  $40 \pm 7\%$  for a pCa trigger of 6.75,  $63 \pm 9\%$  for a pCa trigger of 6.50, and  $95 \pm 3\%$  for a pCa trigger of 6.15. In contrast, the smallest tension transient induced by a pCa trigger of 7.00 was still 40% of the maximum induced by a pCa trigger of 6.25.

A given pCa trigger produced fairly reproducible results, as could be expected inasmuch as these solutions were made by the addition of amounts of total calcium large enough to be easily measurable. However, it must be stressed that the nominal pCa values in the bulk of the solution permit no inference of the exact value of the [free  $\text{Ca}^{2+}$ ] in the vicinity of the SR because of the low level of [total EGTA] (see Fabiato and Fabiato [1975*a*], pp. 477 and 483 and Fig. 3; [1977], p. 121 and Fig. 1A; [1978*a*], pp. 501–508 and Fig. 1). This competition for  $\text{Ca}^{2+}$  between the accumulation of  $\text{Ca}^{2+}$  into the SR and the Ca-EGTA buffer results in a myoplasmic [free  $\text{Ca}^{2+}$ ] lower than that calculated for the solution, except during the  $\text{Ca}^{2+}$  release. This is shown by the absence of any shift of the resting tension or of the baseline of the aequorin signal when the [free  $\text{Ca}^{2+}$ ] was increased up to a pCa of 6.15. This indicates that the actual myoplasmic [free  $\text{Ca}^{2+}$ ] remained below levels at which aequorin (see Fig. 1 of Allen and Blinks [1979]) and the myofilaments (see Fig. 10) are sensitive to  $\text{Ca}^{2+}$ .

A solution at pCa 7.50 resulted in an optimum preload of the SR with  $\text{Ca}^{2+}$  in this preparation (see Fabiato and Fabiato [1979*c*] for rationale). The addition of  $1.0 \times 10^{-6}$  M cyclic AMP increased the relaxation rate but did not significantly modify the amplitude of either the tension transient or the aequorin transient induced by a pCa of 6.25, as opposed to the results obtained with a lower [free  $\text{Ca}^{2+}$ ] trigger and in the presence of a lower [free  $\text{Mg}^{2+}$ ] (See Fig. 8 of Tsien [1977]).

#### *Skinned Cardiac Cells from the Rabbit Ventricle*

To permit comparison between the two animal species, a first series of experiments in the mechanically skinned cells from the rabbit ventricle was



done with the same preload of the SR with Ca<sup>2+</sup> in the presence of pCa 7.50 as used for the mechanically skinned cells from the rat ventricle. One pCa trigger value, however, was different from that used for the rat preparation (6.35 instead of 6.25). The eight rabbit cells used in this experimental series had a width of  $10 \pm 2 \mu\text{m}$  and a length of  $55 \pm 11 \mu\text{m}$ . They developed a maximum tension of  $0.527 \pm 0.075 \text{ mg}$  when fully activated by pCa 4.50 in the presence of 10 mM total EGTA.

No tension transient or bioluminescence transient was induced by an increase of the [free Ca<sup>2+</sup>] to pCa 7.00, 6.75, or 6.50 (Fig. 9*a-c*). A tension transient of  $22 \pm 9\%$  of the maximum tension transient was induced by pCa 6.35 (Fig. 9*d* and point *d* in Fig. 11) and the relative amplitude of the tension transient reached a maximum of  $45 \pm 9\%$  for a pCa trigger of 6.15 (Fig. 9*e*

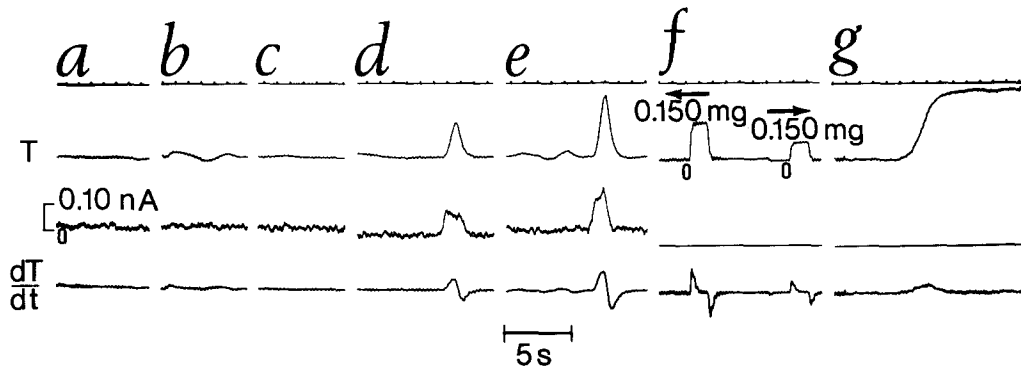

FIGURE 9. Simultaneous recording of tension (T), bioluminescence of aequorin and tension derivative ( $dT/dt$ ) in a  $10\text{-}\mu\text{m}$  wide,  $55\text{-}\mu\text{m}$  long, mechanically skinned cardiac cell from the rabbit ventricle. The same protocol as for Fig. 8 has been followed except that *d* corresponds to a different pCa trigger and the tension calibration has been changed before the application of the high [total EGTA] solutions. No tension or bioluminescence transients were observed when the [free Ca<sup>2+</sup>] was increased to pCa 7.00 (*a*), 6.75 (*b*), or 6.50 (*c*) in the presence of 0.050 mM total EGTA. Transients were induced by pCa 6.35 (*d*) and 6.15 (*e*).

and point *e* in Fig. 11). Further increase in the [free Ca<sup>2+</sup>] used as a trigger resulted in no increase of the amplitude of the tension transient under these conditions of Ca<sup>2+</sup> preload of the SR (data not shown).

The Ca<sup>2+</sup> transient detected by aequorin bioluminescence in the rabbit ventricular skinned cells (Fig. 9) was very different from that observed in the rat ventricular skinned cells: its duration was much longer, lasting during most of the contraction. Sometimes it presented a plateau or an irregular configuration with several components. This suggests that the Ca<sup>2+</sup> release from, and accumulation in, the SR of the rabbit ventricular skinned cells are much slower than those of the rat ventricular skinned cells.

Additional experiments were done to define the optimum conditions of preload of the SR with Ca<sup>2+</sup> and the optimum [free Ca<sup>2+</sup>] used as a trigger after this optimum preload. These experiments included the addition of cyclic

AMP because cyclic AMP has been shown to have a strong effect on the  $\text{Ca}^{2+}$  accumulation in, and release from, the SR of skinned cardiac cells from the rabbit ventricle (see Fig. 15 of Fabiato and Fabiato [1978a]). Then, eight experiments, including only tension recording, were done to quantify the relative amplitude of the tension transient with respect to maximum tension under these optimum conditions. In the absence of cyclic AMP, the optimum preload was with a solution at pCa 6.90, and the optimum [free  $\text{Ca}^{2+}$ ] trigger was pCa 6.15, which resulted in a contraction of  $53 \pm 7\%$  of maximum tension (point *f* in Fig. 11). In the presence of  $1.0 \times 10^{-6}$  M cyclic AMP, the optimum preload was with a solution at pCa 6.80 and the optimum [free  $\text{Ca}^{2+}$ ] trigger was pCa 6.35, which induced a tension transient of  $69 \pm 5\%$  (point *g* in Fig. 11). Increase of the [free  $\text{Ca}^{2+}$ ] trigger above that corresponding to pCa 6.35 under these conditions of optimum loading resulted in a significant decrease of the amplitude of the tension transient:  $59 \pm 7\%$  with a pCa trigger of 6.00 (point *h* in Fig. 11).

*Inference of the Myoplasmic Free Calcium Concentration from the Tension-pCa Curve*

Mechanically skinned cardiac cells, other than those from which the  $\text{Ca}^{2+}$  transients were recorded, were used to establish the tension-pCa relation in the presence of 10 mM total EGTA, pMg 2.50, pMgATP 2.50, pH 7.10, ionic strength 0.160 M, and temperature 22°C. This was done both for rat ventricular cells (Fig. 10) and for rabbit ventricular cells (Fig. 11). Then the means of the relative tensions developed during twitches of intact cells and  $\text{Ca}^{2+}$  transients of mechanically skinned cells were reported on the ordinate of the curve, and the corresponding pCa values were inferred from the curve and its abscissa.

For the rat ventricular cells, there was no significant difference between the relative tension developed during the maximum twitch of the intact cells and during the maximum tension transients by  $\text{Ca}^{2+}$ -induced release of  $\text{Ca}^{2+}$  from the SR of the mechanically skinned cells (points A and *d* in Fig. 10). The myoplasmic [free  $\text{Ca}^{2+}$ ] reached a pCa of 5.30–5.40 during this maximum positive inotropism in both preparations. This is well below the pCa of  $\sim 4.90$  necessary to saturate the myofilaments with  $\text{Ca}^{2+}$ .

In the absence of pharmacological intervention a maximum myoplasmic [free  $\text{Ca}^{2+}$ ] of  $\sim 5.60$  was inferred from the tension-pCa curve for both the intact and skinned cells from the rabbit ventricle (points B and *f* in Fig. 11). The experiments in the presence of pharmacological agents suggest that about the same pCa,  $\sim 5.40$ , as observed with the rat cells can be reached in these rabbit intact and skinned cells under conditions of optimum  $\text{Ca}^{2+}$  preload of the SR. However, there is some uncertainty about these results because the pharmacological agents may modify the sensitivity of the myofilaments to  $\text{Ca}^{2+}$ . For the skinned cells, the maximum myoplasmic [free  $\text{Ca}^{2+}$ ] reached in the presence of cyclic AMP (point *g* in Fig. 11) inferred from a tension-pCa curve obtained in the absence of this agent may be accurate inasmuch as  $1.0 \times 10^{-6}$  M cyclic AMP does not modify the tension-pCa curve of skinned

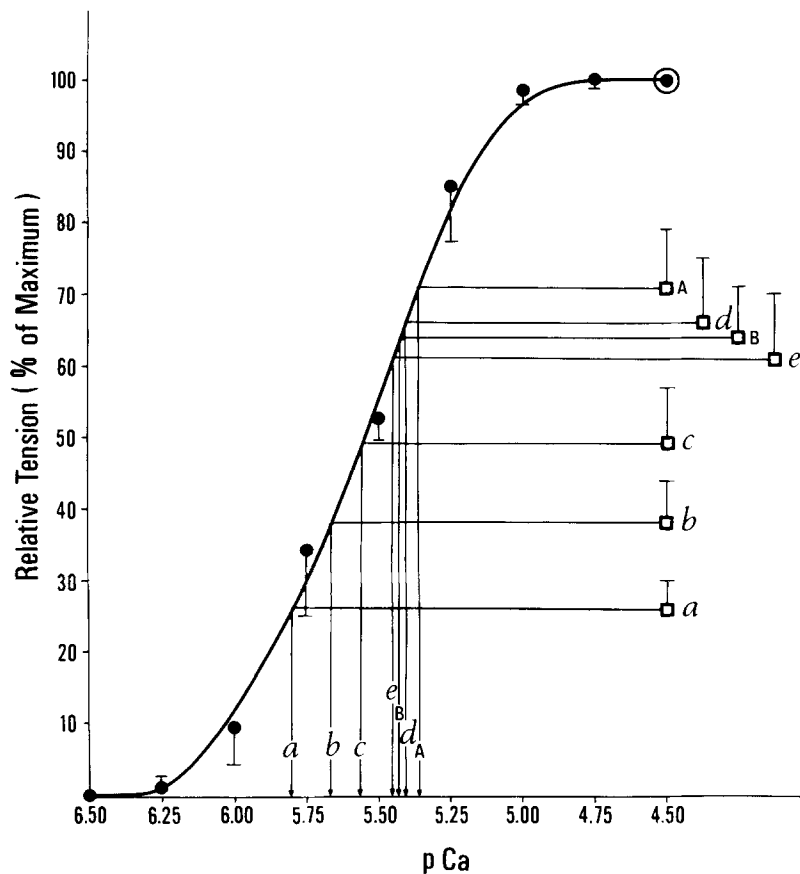

FIGURE 10. Rat ventricular cells: inference of the myoplasmic [free  $\text{Ca}^{2+}$ ] reached during the twitch of intact cells (*capital letters*) and the  $\text{Ca}^{2+}$ -induced release of  $\text{Ca}^{2+}$  from the SR of skinned cardiac cells (*lower case italic letters*) from the tension-pCa relation of skinned cardiac cells. Each point represents the mean and each vertical bar represents the SD (shown in one direction only). The number of observations was 7 for each data point on the twitch of intact cells, 10 for each data point on tension transients of skinned cardiac cells, and 6–9 for the tension-pCa curve in skinned cardiac cells. For the intact cells: A, twitch during regular single-pulse stimulation at 12/min in the presence of 2.50 mM free  $\text{Ca}^{2+}$ ; B, twitch during paired-pulse stimulation under the same conditions as for A. For the mechanically skinned cardiac cells, the  $\text{Ca}^{2+}$  transients were induced by an increase in 0.2 s of the [free  $\text{Ca}^{2+}$ ] from pCa 7.50 to pCa 7.00 for *a*, 6.75 for *b*, 6.50 for *c*, 6.25 for *d*, and 6.15 for *e*.

cardiac cells (see Fig. 15 of Tsien [1977]). In contrast, the maximum myoplasmic [free  $\text{Ca}^{2+}$ ] reached in the intact cells in the presence of isoproterenol (point D in Fig. 11) may have been underestimated, inasmuch as there is some evidence that isoproterenol decreases the sensitivity of the myofilaments to  $\text{Ca}^{2+}$  (McClellan and Winegrad, 1978; Winegrad, 1979a; Holroyde et al.,

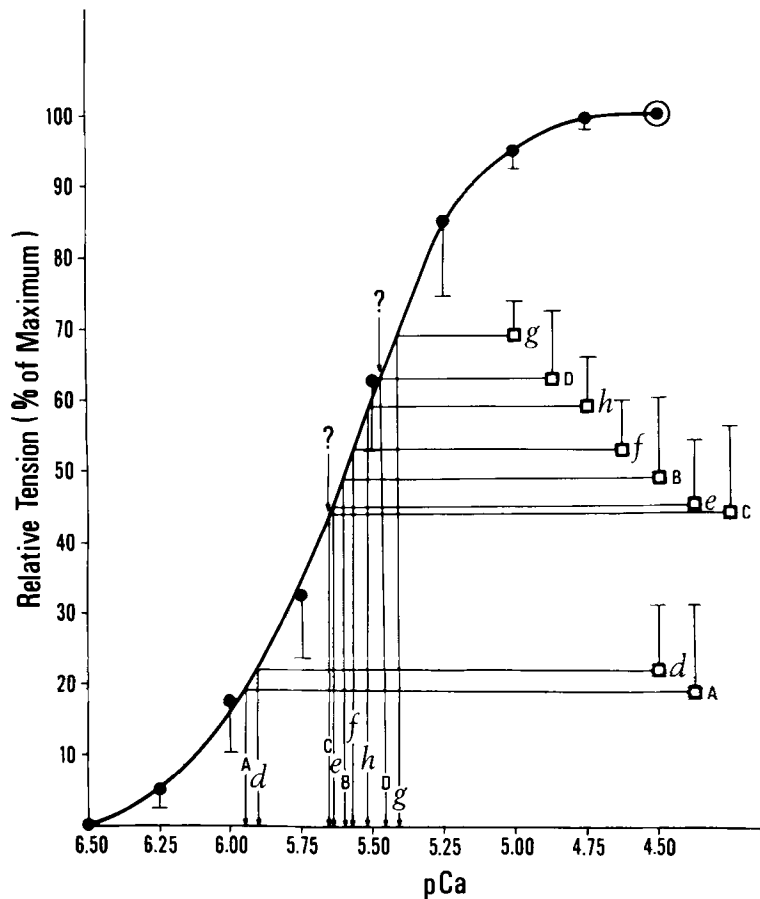

FIGURE 11. Rabbit ventricular cells: inference of the myoplasmic [free  $\text{Ca}^{2+}$ ] reached during the twitch of intact cells (*capital letters*) and the  $\text{Ca}^{2+}$ -induced release of  $\text{Ca}^{2+}$  from the SR of skinned cardiac cells (*lower case italic letters*) from the tension-pCa relation of skinned cardiac cells. Each point represents the mean and each vertical bar represents the SD (shown in one direction only). The number of observations was 9 for each data point on the twitch of intact cells, 8 for each data point on tension transients of skinned cardiac cells, and 6–10 for the tension-pCa curve in skinned cardiac cells. For the intact cells: A, twitch during regular single-pulse stimulation at 12/min in the presence of 2.50 mM free  $\text{Ca}^{2+}$ ; B, twitch during paired-pulse stimulation at optimum interval under the same conditions as for A; C, twitch during single-pulse stimulation in the presence of  $1.0 \times 10^{-6}$  M isoproterenol; D, twitch during paired-pulse stimulation in the presence of  $1.0 \times 10^{-6}$  M isoproterenol (for C and D, the interrogation marks on the curve reflect the uncertainty about the validity of this curve in the presence of isoproterenol). For the mechanically skinned cardiac cells, the  $\text{Ca}^{2+}$  transients were induced by an increase, in 0.2 s, of the [free  $\text{Ca}^{2+}$ ] from pCa 7.50 to pCa 6.35 for *d*, from pCa 7.50 to pCa 6.15 for *e*, from pCa 6.90 to 6.15 for *f*, from pCa 6.80 with  $1.0 \times 10^{-6}$  M cyclic AMP to pCa 6.35 for *g*, and from 6.80 with  $1.0 \times 10^{-6}$  M cyclic AMP to pCa 6.00 for *h*. There are no points *a–c* because no  $\text{Ca}^{2+}$  transients were induced by an increase of [free  $\text{Ca}^{2+}$ ] from pCa 7.50 to a pCa 7.00, 6.75, or 6.50.

1979; Mope et al., 1980; Marban et al., 1980), at least in the presence of a phosphodiesterase inhibitor (theophylline or caffeine).

*Inference of the Myoplasmic Free Calcium Concentration from a Direct Calibration of the Aequorin Bioluminescence Signals*

In 10 additional mechanically skinned cardiac cells from the rat ventricle, the [free Ca<sup>2+</sup>] reached during the Ca<sup>2+</sup> transient was directly inferred from a calibration of the aequorin signal suggested by Dr. John R. Blinks (personal communication; and Allen and Blinks, 1979). The Ca<sup>2+</sup> transients (Fig. 12) were induced under similar conditions as in the other experiments except that no solution at pCa 6.15 was applied (so that there is no panel *e* in Fig. 12). The values of relative amplitude of the Ca<sup>2+</sup> transient expressed as a percentage of that observed for the maximum Ca<sup>2+</sup> release induced by a pCa trigger of 6.25 (Fig. 12*d*) did not differ significantly from those observed in the previous experimental series: 23 ± 6% for a pCa trigger of 7.00 (Fig. 12*a*), 44 ± 5% for a pCa trigger of 6.75 (Fig. 12*b*), and 59 ± 8% for a pCa trigger of 6.50 (Fig. 12*c*). At the end of the experiment, most of the aequorin-containing solution was re-aspirated so that only the amount of solution contained in the skinned cell remained present. The application of a solution at pCa 2.50 in the presence of 0.050 mM total EGTA resulted in a large bioluminescence transient which was recorded at a thousand times lower sensitivity (Fig. 12*f*). The microcomputer display of the area under the curve of this signal was used to infer the absolute maximum light that would have been generated by the instantaneous mixing of all the aequorin contained in the skinned cell with a saturating [free Ca<sup>2+</sup>] (Methods; and Fig. 12*f*). Then the calibration curve obtained during rapid mixing in a cuvette of aequorin and Ca<sup>2+</sup> (see Fig. 1 of Allen and Blinks [1979]) was used to infer the pCa reached during Ca<sup>2+</sup> release (Fig. 13).

The values of myoplasmic [free Ca<sup>2+</sup>] obtained with this direct calibration of the aequorin bioluminescence signals are not identical to those inferred from the tension-pCa curve but none differ by >0.1 pCa unit. The major difference between the two sets of data is that the range of myoplasmic [free Ca<sup>2+</sup>] measured was narrower with the direct calibration of the aequorin signal: 0.3 instead of 0.4 pCa unit. Another expression of this difference is derived from a double  $-\log_{10}$  plot of the relative amplitude of the aequorin signal as a function of the myoplasmic [free Ca<sup>2+</sup>] inferred from the tension-pCa curve. The corresponding data points are well fitted by a straight line, but with a slope of 2.00 (Fig. 14) instead of 2.50. This difference may be explained by the fact that the slope of the tension-pCa curve of skinned fibers is artifactually decreased when averaged data from several fibers are pooled to obtain the curve. A much higher slope is obtained when all the data points are derived from the same fiber (Brandt et al., 1980).

Inasmuch as the preceding results suggest that the peak of the aequorin bioluminescence signal and that of the tension transient reflect the same [free Ca<sup>2+</sup>], the delay between these two peaks requires explanation. The Ca<sup>2+</sup> that is released from the SR may bind to troponin C with the rate constant in the

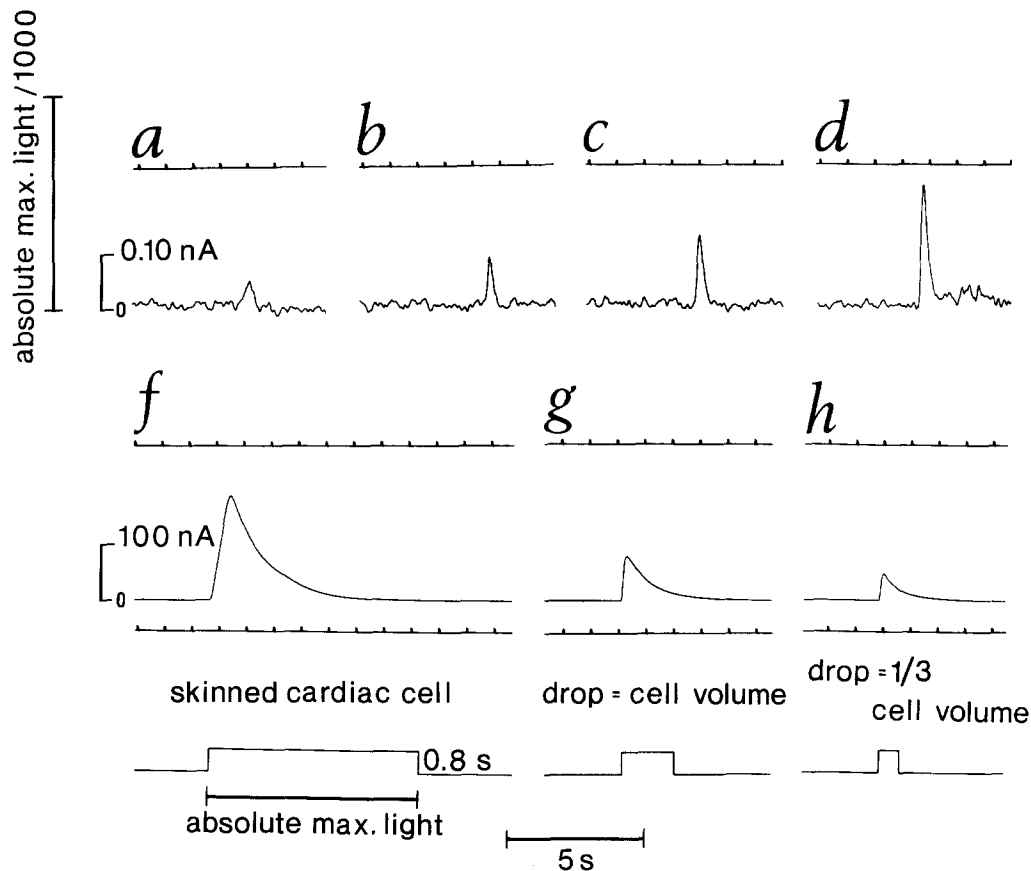

FIGURE 12. Recording of aequorin bioluminescence in a  $9\text{-}\mu\text{m}$  wide,  $58\text{-}\mu\text{m}$  long, skinned cardiac cell from the rat ventricle. The transients of aequorin bioluminescence were triggered by an increase of [free  $Ca^{2+}$ ] in the solution from pCa 7.50 to pCa 7.00 (a), 6.75 (b), 6.50 (c), and 6.25 (d). In these solutions [total EGTA] was 0.050 mM, pMg 2.50, pMgATP 2.50, pH 7.10, and ionic strength 0.160 M. At the end of the experiment, most of the aequorin-containing solution was aspirated so that only the aequorin contained in the skinned cell remained present. Then a solution with pCa 2.50 and the same pMg, pMgATP, pH, and [total EGTA] was applied. This resulted in a large transient of aequorin bioluminescence (f). The lower trace in f is a microcomputer-generated rectangular wave with a height equal to the time constant (0.8 s) of the bioluminescence decay as given by Allen and Blinks (1979). Consequently, the length of the rectangular wave, displayed at a chart recorder speed of 1 cm/s, is equal to the amplitude of the ordinate intercept of the theoretical curve of instantaneous use of all the aequorin contained in the cell. This gives the calibration of absolute maximum light, which is used to express the relative amplitude of the aequorin transients caused by  $Ca^{2+}$  release from the SR. In g, the same application of solution with pCa 2.50 was done in a drop of aequorin-containing solution of volume equal to that of the skinned cell. In h, the same experiment was done in another drop equal to one-third of the cell volume.

millisecond range that has been established by biochemical data (Johnson et al., 1979). Part of the delay between this binding of Ca<sup>2+</sup> to troponin C and the generation of the tension may be caused by the cross-bridge cycle (see Brandt et al. [1980] for this new rationale) that includes reactions with rate constants several orders of magnitude lower (Levy et al., 1976; Moiescu, 1976; Borejdo and Morales, 1977), whereas another part of this delay may be artifactual and caused by the compliance of the transducer.

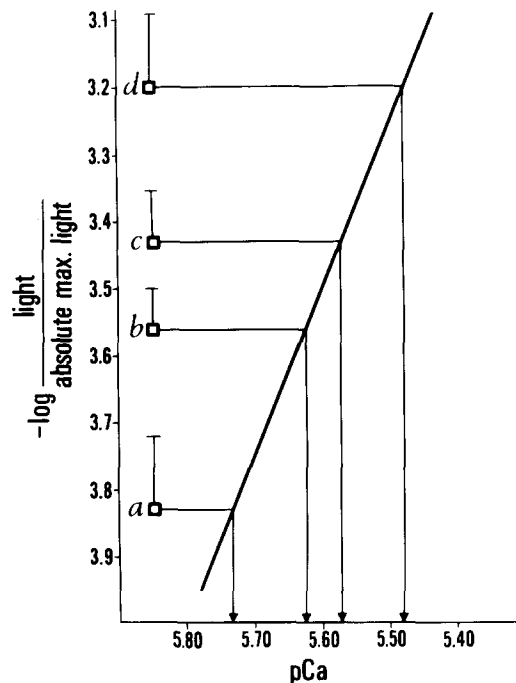

FIGURE 13. Inference of myoplasmic pCa from the  $-\log_{10}$  of the ratio between the amplitude of aequorin bioluminescence transient (*light*) caused by Ca<sup>2+</sup> release from the SR and the peak of light which would have been produced by the instantaneous use of all the aequorin contained in the skinned cell (*absolute max. light*). The straight line of calibration is a segment of the curve shown in Fig. 1 of Allen and Blinks (1979) that these investigators obtained under conditions close to those used in the present study.

The preceding hypothesis is supported by the observation that a solution at pCa 9.00 applied during the descending phase of the aequorin signal immediately decreased the bioluminescence but did not modify the amplitude of the tension transient (Fig. 15). This suggests that the steps occurring during the delay between Ca<sup>2+</sup> transient and tension development are Ca<sup>2+</sup> independent. Thus the amplitude of the contraction would be determined at or about at the time of the peak of the bioluminescence transient. Whether the relaxation rate is also predetermined, a possibility suggested by Gordon and

Ridgway (1978), is not clearly established by the preliminary experiment shown in Fig. 15.

More experiments of this type are planned with the aim of defining the relationship between  $\text{Ca}^{2+}$  movements and contraction and relaxation. The skinned cardiac cells provide a very favorable preparation for these experi-

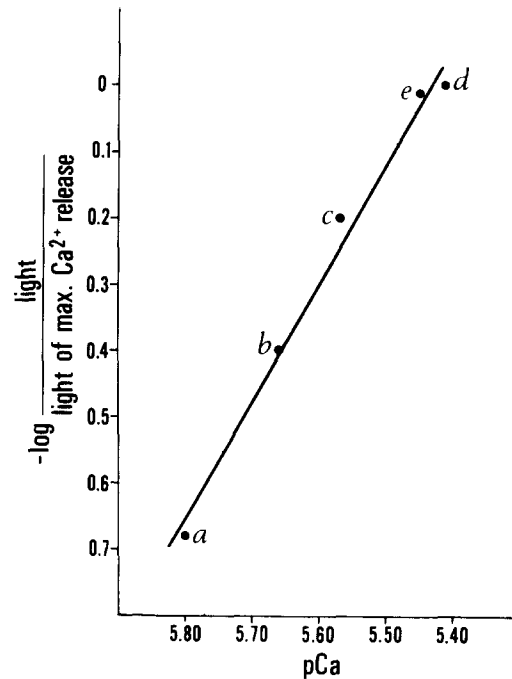

FIGURE 14. Double  $-\log_{10}$  plot of the relative amplitude of the aequorin bioluminescence signal as a function of the myoplasmic [free  $\text{Ca}^{2+}$ ] inferred from the tension-pCa curve in 10 mechanically skinned cardiac cells from the rat ventricle. The letters labeling the data points correspond to those of Fig. 10. For each skinned cell, the amplitude of each transient of aequorin bioluminescence induced by a given pCa trigger (*light*) was expressed relatively to the amplitude of the bioluminescence transient induced by the optimum pCa trigger of 6.25 (*light of max.  $\text{Ca}^{2+}$  release*) in the same cell. Then, the ratios obtained with each pCa trigger in all the skinned cells were averaged. (The corresponding percentages and their SD are given in the section of Results on the skinned cardiac cells from the rat ventricle.) The  $-\log_{10}$  of these averaged ratios were plotted as a function of the myoplasmic pCa level inferred from the tension-pCa curve (Fig. 10).

ments because their 4–5- $\mu\text{m}$  radius renders a significant diffusion delay unlikely (Crank, 1975) and because the  $\text{Ca}^{2+}$  transient is very slow and the delay between it and the tension transient is very long. In addition, the fine micromanipulations used in skinned cardiac cells are much less likely to damage the myofilaments than the dissection with hand-held needles (Ford



and Podolsky, 1972) or the tearing in two parts with forceps (Endo and Blinks, 1973) used for skinned skeletal muscle fibers.

The high signal-to-noise ratio obtained in these preparations made of one-sixth to one-fifth the volume of a single cardiac cell was totally unexpected in view of the results obtained by Allen and Blinks (1978 and 1979) and Wier (1980) with multiple averaging of signals produced after multiple injections in multicellular preparations of cardiac muscle. A partial explanation of this finding is suggested by the experiments shown in Fig. 12*g* and *h*. The same protocol as used for the calibration was done in a drop of the same aequorin-containing solution used for the experiments, but which contained no cell. The volume of the drop was either that of the skinned cell (Fig. 12*g*) or one-third of this volume (Fig. 12*h*) because mitochondria, myofilaments, and SR may occupy up to two-thirds of the volume of the cell. In 10 experiments, the area under the curve of the aequorin signal was  $28 \pm 6\%$  of that obtained with the aequorin contained in the skinned cell for a drop volume equal to that of the cell (Fig. 12*g*) and  $9 \pm 3\%$  for a drop of one-third of the cell volume (Fig. 12*h*). This supports a suggestion made by Dr. John R. Blinks (personal communication, 1981) that the skinned cardiac cells may concentrate aequorin. The volume of these drops was precisely reproducible as controlled by the measurement of their diameter under microscope, although the data do not permit a quantitative inference of the concentration of aequorin within the skinned cell inasmuch as the exact fraction of the cell volume available for its diffusion has not been determined.

In five additional experiments, the protocol shown in Fig. 12*f-h* was repeated, but with the use of a skinned cell that had been pretreated by a 30-min exposure to 0.5% of the detergent Brij 58 in a solution at pCa 9.00 and then bathed for 30 min in an aequorin-containing solution with pCa 6.25, 0.050 mM total EGTA, pMg 2.50, pMgATP 2.50, pH 7.10, and ionic strength of 0.160 M. The ratios of the areas under the aequorin signals were  $24 \pm 7\%$  of the skinned cell signal for a drop equal to the volume of the detergent-treated skinned cell and  $10 \pm 4\%$  for a drop of one-third of the skinned cell volume. The absence of a significant difference between these results and those obtained for skinned cells with intact SR does not definitely demonstrate that aequorin binds to the myofilaments rather than to the SR, for the detergent treatment may only suppress the ability of the SR to actively accumulate and release Ca<sup>2+</sup> but not its binding ability (see Fabiato and Fabiato [1975*a* and 1978*c*] for rationale and references to the literature).

Another observation that may be pertinent to the aequorin binding within the skinned cell is that although the cyclic contractions reached their maximum amplitude almost instantaneously during the 30-min equilibration period mentioned in Methods, the cyclic aequorin bioluminescence transients increased by a factor of up to three for ~5 min and then remained stable. Despite the large size of the aequorin molecule, it is unlikely that this very long delay is caused by its simple diffusion within a skinned cell of  $<5 \mu\text{m}$  radius. Finally, the present data would suggest that the affinity of the aequorin bound within the cell for Ca<sup>2+</sup> is identical to that of the aequorin in the solution inasmuch as the myoplasmic [free Ca<sup>2+</sup>] could be predicted accurately from the calibration curve obtained in cuvette by Allen and Blinks

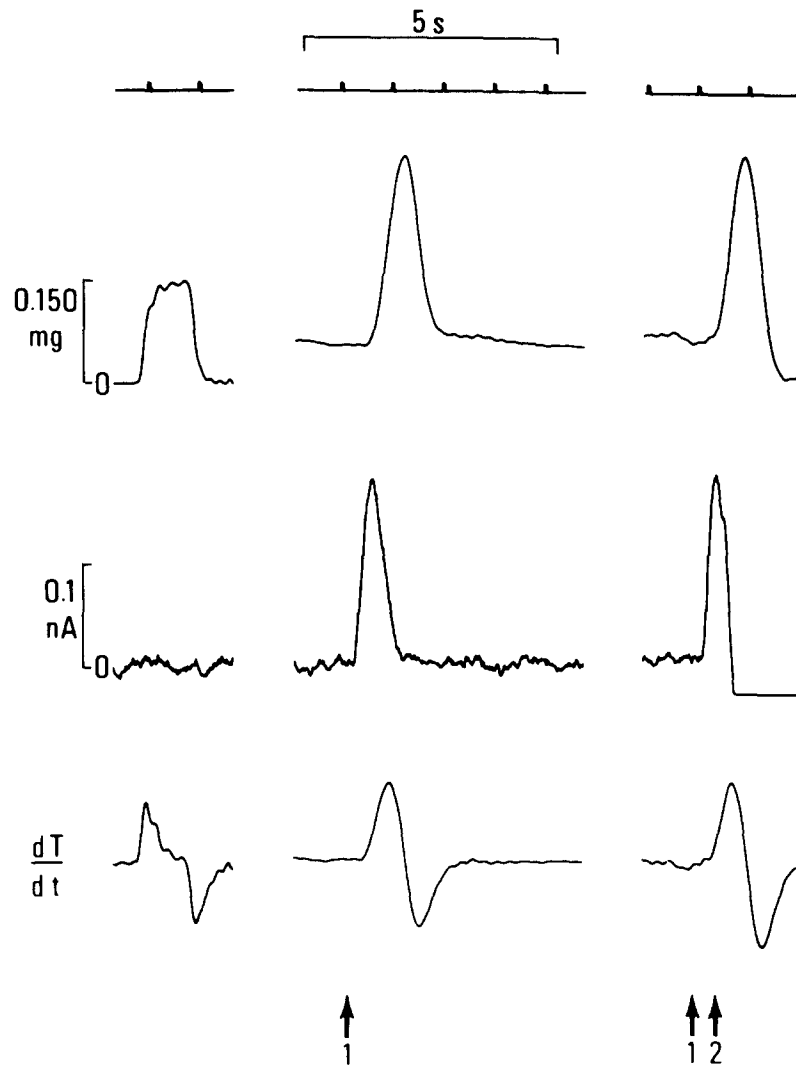

FIGURE 15. Interruption of the  $\text{Ca}^{2+}$  transient during its descending phase by the microinjection of a solution at pCa 9.00. The experiment was done in the  $8\text{-}\mu\text{m}$  wide,  $49\text{-}\mu\text{m}$ -long, mechanically skinned cardiac cell from the rat ventricle. The recordings are from top to bottom: tension (calibration  $0.150\text{ mg}$ ), aequorin bioluminescence (scale =  $0.1\text{ nA}$ ), and time derivative of the tension ( $dT/dt$ ). With the intention of exaggerating the delay between  $\text{Ca}^{2+}$  transient and tension transient, the experiment was done in the presence of a pMgATP of 4.00 instead of the pMgATP 2.50 used in all the other experiments. This resulted in a larger resting tension, which was cancelled by EGTA (see Fabiato and Fabiato, [1975 *b*]). All solutions had a pMg of 2.50 and a pH of 7.10. That the pCa 9.00 microinjection caused the aequorin bioluminescence tracing to decrease beyond the limits of the recorder channel is explained by the decrease of the resting glow (see Methods for the definition of the zero of the bioluminescence recording). The reference condition was a pCa of 7.50 in the presence of  $0.050\text{ mM}$

(1979). Since aequorin is a large molecule with many possible binding sites (Blinks et al., 1976), the site that binds Ca<sup>2+</sup> might be different from that (or those) binding aequorin within the cell.

Further test of the consistency of the myoplasmic [free Ca<sup>2+</sup>] values inferred by the two methods used in the present study will be sought by studying the effects of changes of pH or pMg that may differentially affect the Ca<sup>2+</sup> sensitivity of aequorin (Allen and Blinks, 1979; Moiescu and Ashley, 1977) and the myofilaments (Fabiato and Fabiato, 1975*b* and 1978*b*). If aequorin were to bind only to the myofilaments, the responses of both aequorin (bioluminescence) and troponin C (tension) could lead to an underestimation of the transient increase of [free Ca<sup>2+</sup>] taking place in the vicinity of the SR, where the aequorin concentration would be lower. However, the circulation of Ca<sup>2+</sup> and the resulting gradients of myoplasmic [free Ca<sup>2+</sup>] might be more limited than generally thought (Page and Surdyk-Droske, 1979) if Ca<sup>2+</sup> were to be released from all the segments of the SR that tightly pack the myofilaments rather than from the terminal cisternae only. This hypothesis is supported by the observation of a well-developed, Ca<sup>2+</sup>-induced release of Ca<sup>2+</sup> from the SR in the mammalian atrial cells (Fabiato and Fabiato, 1978*a*) as well as in the canine cardiac Purkinje cells and the pigeon ventricular cells (unpublished data). The lack of transverse tubules in these cells would suggest that all the terminal cisternae of the SR forming dyadic junctions are removed with the sarcolemma by the skinning procedure.

#### DISCUSSION

The present results suggest that the maximum limit to the amplitude of the twitch of the intact mammalian cardiac cell is not caused by a saturation of the myofilaments with Ca<sup>2+</sup> but by a limit to the amount of Ca<sup>2+</sup> that can be accumulated in, and released from, the SR. In themselves, the tension recordings show that the level of tension reached during both the twitch of the intact cells and the contraction transient of the skinned cells is far from reaching that attained during full activation of the myofilaments. The measurements by two different methods of the myoplasmic [free Ca<sup>2+</sup>] reached during Ca<sup>2+</sup> release confirm this finding and suggest, with the previously discussed reservations, that a myoplasmic [free Ca<sup>2+</sup>] of pCa ~5.40 is attained

---

total EGTA. *Arrow 1*: microinjection, within 0.2 s, of a solution with pCa 6.25 in the presence of 0.050 mM total EGTA. *Arrow 2*: microinjection of a solution with pCa 9.00 in the presence of 4.00 mM total EGTA within 0.1 s. This 0.1-s solution change was obtained by injecting a large volume of the pCa 9.00 solution (20 nl) without an aspiration of the previous solution. To facilitate diffusion, the solutions containing 0.050 mM total EGTA also contained 3.950 mM hexamethylenediamine *NNN'*-tetraacetic acid (HDTA) (see Fabiato and Fabiato [1979*b*] for rationale). That the diffusion of the pCa 9.00 solution within the skinned cardiac cell took place within a few milliseconds was demonstrated by experiments in which this solution was applied during the ascending phase of the Ca<sup>2+</sup> transient: this resulted in a decrease of the amplitude of the tension transient.

during the maximum twitch, whereas a pCa of  $\sim 4.90$  is required for the full activation of the myofilaments. These results also suggest that for both the rat and rabbit ventricle, the  $\text{Ca}^{2+}$ -induced release of  $\text{Ca}^{2+}$  from the SR of the skinned cells can deliver enough  $\text{Ca}^{2+}$  to account for even the maximum twitch of the intact cells (with some uncertainty, however, about the rabbit ventricular cells).

Neither the present study nor any previous studies (Fabiato and Fabiato, 1975*a* and *b*, 1977, 1978*a* and *b*, and 1979*c*) claim a definition of the transsarcolemmal  $\text{Ca}^{2+}$  influx necessary for triggering  $\text{Ca}^{2+}$  release from the SR. The trigger is not a given level of [free  $\text{Ca}^{2+}$ ], but a change of [free  $\text{Ca}^{2+}$ ] during a given time (Fabiato and Fabiato, 1979*c*). Thus the same change of [free  $\text{Ca}^{2+}$ ] can either load the SR or induce a  $\text{Ca}^{2+}$  release, depending upon whether it is applied slowly (5.0 s) or rapidly (0.2 s) (Fabiato and Fabiato, 1979*c*). The only values of concentration that might give an idea of the range of the transsarcolemmal  $\text{Ca}^{2+}$  influx required for triggering  $\text{Ca}^{2+}$  release from the SR are those corresponding to a change in 0.2 s, as used in the present study. If experiments in intact multicellular preparations of cardiac muscle succeed in defining the systolic transsarcolemmal influx of  $\text{Ca}^{2+}$  (see Tsien, [1977], and Isenberg and Klöckner [1980] for discussion and references to the literature), it will also be very difficult to infer the resulting change of [free  $\text{Ca}^{2+}$ ] in the vicinity of the SR since the resulting myoplasmic [free  $\text{Ca}^{2+}$ ] will not be homogeneous throughout the volume of the cell. How the binding capacity for  $\text{Ca}^{2+}$  of the content of the intact cardiac cell compares with that of 0.050 mM total EGTA is unknown. Data in skinned cardiac cells in which the  $\text{Ca}^{2+}$  release was induced in the presence of a high [total EGTA] were useful for studying some properties of the SR membrane (Fabiato and Fabiato, 1977, 1978*a* and *b*, and 1979*c*), but did not help in defining the range of transsarcolemmal influx of  $\text{Ca}^{2+}$  necessary for triggering  $\text{Ca}^{2+}$  release from the SR, precisely because these data were obtained under conditions imposing an unphysiologically homogeneous [free  $\text{Ca}^{2+}$ ] throughout the volume of the cell. Thus, the previous studies did not use any quantitative assessment of the magnitude of the physiological  $\text{Ca}^{2+}$  trigger for testing the hypothesis of a  $\text{Ca}^{2+}$ -induced release of  $\text{Ca}^{2+}$  from the SR. The conclusion of these studies was the suggestion that no transsarcolemmal  $\text{Ca}^{2+}$  influx of  $\text{Ca}^{2+}$ , however small it may be, could activate the myofilaments without first triggering a  $\text{Ca}^{2+}$  release from the SR. This was proposed both for the rat ventricle in which the  $\text{Ca}^{2+}$ -induced release of  $\text{Ca}^{2+}$  is the most easily obtained (see Fig. 10 of Fabiato and Fabiato [1978*a*]) and for the rabbit ventricle in which the  $\text{Ca}^{2+}$ -induced release of  $\text{Ca}^{2+}$  is the least easily obtained among the adult mammalian ventricular tissues (see Fig. 11 of Fabiato and Fabiato [1978*a*]).

Similarly, the interpretation of the results of the present study does not require a quantification of the transsarcolemmal influx of  $\text{Ca}^{2+}$  triggering  $\text{Ca}^{2+}$  release. These results suggest that no transsarcolemmal influx of  $\text{Ca}^{2+}$ , however large it may be, can saturate the myofilaments because of the interference of the  $\text{Ca}^{2+}$ -induced release of  $\text{Ca}^{2+}$  from the SR, which would be the limiting step. The  $\text{Ca}^{2+}$ -induced release of  $\text{Ca}^{2+}$  appears to be graded with the level of [free  $\text{Ca}^{2+}$ ] used as a trigger and with the preload of the SR with

Ca<sup>2+</sup> (present results), as well as with the rate of change of [free Ca<sup>2+</sup>] (Fabiato and Fabiato, 1979*c*). However, the amount of Ca<sup>2+</sup> released by the Ca<sup>2+</sup>-induced process reaches a maximum above which further increase of the [free Ca<sup>2+</sup>] trigger or of the preload does not produce a further increase in the amount of Ca<sup>2+</sup> released from the SR. An excessive increase of the [free Ca<sup>2+</sup>] trigger or of the preload can even decrease the amount of Ca<sup>2+</sup> delivered to the myofilaments (present results). This is consistent with the finding that an increase of the [free Ca<sup>2+</sup>] to 12 mM in the extracellular medium decreases the amplitude of the twitch of the intact multicellular preparations from the rat ventricle (Aronson and Capasso, 1980). Until now, technical limitations have prevented the perfusion change from being fast enough to permit an assessment of the hypothesis that an excessive rate of change of [free Ca<sup>2+</sup>] might also decrease the Ca<sup>2+</sup> release when the two other known factors (Ca<sup>2+</sup> preload and level of [free Ca<sup>2+</sup>]) are optimum.

This conclusion applies only to the twitch of the intact adult mammalian cardiac cell. With respect to the contracture in the intact isolated cells, it can only be stated (because this article is not directly concerned with this subject) that neither the replacement of the extracellular Na<sup>+</sup> by choline in the presence of  $1.0 \times 10^{-7}$  M digitalis nor the replacement of Na<sup>+</sup> by K<sup>+</sup> resulted in the development (either initially or after many minutes) of a contracture >85% of the maximum tension induced after chemical skinning of the cell in any of the experiments. The role of the SR in the limitation of this contracture level is much more difficult to demonstrate than for the twitch because of the interference of the Ca<sup>2+</sup> accumulation in the mitochondria.

That an optimum Ca<sup>2+</sup> release requires much less loading and a much lower [free Ca<sup>2+</sup>] trigger in the rat than in the rabbit ventricle is consistent with the differences between the properties of the excitation-contraction coupling of the intact isolated cells (this study) and multicellular preparations from the same two animal species. Although the contraction of the rabbit ventricular muscle increases in amplitude for a wide range of increase of extracellular [free Ca<sup>2+</sup>], that of the rat ventricular muscle saturates at 2–5 mM extracellular free Ca<sup>2+</sup> (Henderson et al., 1969; Forester and Mainwood, 1974) and decreases at 12 mM (Aronson and Capasso, 1980). The negative staircase observed in the rat ventricle may have several explanations, such as an excessive level of [free Ca<sup>2+</sup>] trigger when the Ca<sup>2+</sup> preload is already optimum, or perhaps (not testable with available techniques) an excessive rate of change of [free Ca<sup>2+</sup>] when the two other parameters are already at optimum levels.

I thank Dr. Ellis B. Ridgway for giving the aequorin and for much generous advice and helpful discussions, Dr. John R. Blinks for the advice which is acknowledged in the text, my wife (who has interrupted her work) for her help in the development of the intact isolated adult cardiac cell preparations, and Dr. Robert Weingart for his personal communication.

This study was supported by grants 5 RO1 HL19138-04 and 5 RO1 HL1938-05 from the National Heart, Lung and Blood Institute and by grant 78-1137 from the American Heart Association.

*Received for publication 12 January 1981.*

## REFERENCES

- ALLEN, D. G., and J. R. BLINKS. 1978. Calcium transients in aequorin-injected frog cardiac muscle. *Nature (Lond.)* **273**:509-513.
- ALLEN, D. G., and J. R. BLINKS. 1979. The interpretation of light signals from aequorin-injected skeletal and cardiac muscle cells: a new method of calibration. *In* Detection and Measurement of Free  $\text{Ca}^{2+}$  in Cells. C. C. Ashley and A. K. Campbell, editors. Elsevier/North Holland Biomedical Press, Amsterdam. 159-174.
- ALTSCHULD, R., L. GIBB, A. ANSEL, C. HOHL, F. A. KRUGER, and G. P. BRIERLEY. 1980. Calcium tolerance of isolated rat heart cells. *J. Mol. Cell. Cardiol.* **12**:1383-1395.
- ARONSON, R. S., and J. M. CAPASSO. 1980. Negative inotropic effect of elevated extracellular calcium in rat myocardium. *J. Mol. Cell. Cardiol.* **12**:1305-1309.
- BERRY, M. N., D. S. FRIEND, and J. SCHEUER. 1970. Morphology and metabolism of intact muscle cells isolated from adult rat heart. *Circ. Res.* **26**:679-687.
- BLINKS, J. R., F. G. PRENDERGAST, and D. G. ALLEN. 1976. Photoproteins as biological calcium indicators. *Pharmacol. Rev.* **28**:1-93.
- BLOOM, S. 1970. Spontaneous rhythmic contraction of separated heart muscle cells. *Science (Wash. D. C.)* **167**:1727-1729.
- BODEM, R., and E. H. SONNENBLICK. 1975. Mechanical activity of mammalian heart muscle: variable onset, species differences, and the effect of caffeine. *Am. J. Physiol.* **228**:250-261.
- BOREJDO, J., and M. F. MORALES. 1977. Fluctuations in tension during contraction of single muscle fibers. *Biophys. J.* **20**:315-334.
- BRADY, A. J., S. T. TAN, and N. V. RICCHIUTI. 1979. Contractile force measured in unskinned isolated adult rat heart fibres. *Nature (Lond.)* **282**:728-729.
- BRANDT, P. W., R. N. COX, and M. KAWAI. 1980. Can the binding of  $\text{Ca}^{2+}$  to two regulatory sites on troponin C determine the steep pCa/tension relationship of skeletal muscle? *Proc. Natl. Acad. Sci. U. S. A.* **77**:4717-4720.
- BRUTSAERT, D. L., N. M. DE CLERCK, M. A. GOETHALS, and P. R. HOUSMANS. 1978. Relaxation of ventricular cardiac muscle. *J. Physiol. (Lond.)* **283**:469-480.
- CRANK, J. 1975. *The Mathematics of Diffusion*. Clarendon Press, Oxford. 2nd ed.
- DE HEMPTINNE, A. 1980. Intracellular pH and surface pH in skeletal and cardiac muscle measured with a double-barrelled pH microelectrode. *Pfluegers Arch. Eur. J. Physiol.* **386**:121-126.
- ENDO, M., and J. R. BLINKS. 1973. Inconstant association of aequorin luminescence with tension during calcium release in skinned muscle fibres. *Nat. New Biol.* **246**:218-221.
- FABIATO, A., and F. FABIATO. 1972. Excitation-contraction coupling of isolated cardiac fibers with disrupted or closed sarcolemmas. Calcium-dependent cyclic and tonic contractions. *Circ. Res.* **31**:293-307.
- FABIATO, A., and F. FABIATO. 1975a. Contractions induced by a calcium-triggered release of calcium from the sarcoplasmic reticulum of single skinned cardiac cells. *J. Physiol. (Lond.)* **249**:469-495.
- FABIATO, A., and F. FABIATO. 1975b. Effects of magnesium on contractile activation of skinned cardiac cells. *J. Physiol. (Lond.)* **249**:497-517.
- FABIATO, A., and F. FABIATO. 1976. Techniques of skinned cardiac cells and of isolated cardiac fibers with disrupted sarcolemmas with reference to the effects of catecholamines and of caffeine. *In* Recent Advances in Studies on Cardiac Structure and Metabolism. Vol. 9: The Sarcolemma. P.-E. Roy and N. S. Dhalla, editors. University Park Press, Baltimore. 71-94.
- FABIATO, A., and F. FABIATO. 1977. Calcium release from the sarcoplasmic reticulum. *Circ. Res.* **40**:119-129.

- FABIATO, A., and F. FABIATO. 1978 *a*. Calcium-induced release of calcium from the sarcoplasmic reticulum of skinned cells from adult human, dog, cat, rabbit, rat, and frog hearts and from fetal and new-born rat ventricles. *Ann. N. Y. Acad. Sci.* **307**:491-522.
- FABIATO, A., and F. FABIATO. 1978 *b*. Effects of pH on the myofilaments and the sarcoplasmic reticulum of skinned cells from cardiac and skeletal muscles. *J. Physiol. (Lond.)*. **276**:233-255.
- FABIATO, A., and F. FABIATO. 1978 *c*. Myofilament-generated tension oscillations during partial calcium activation and activation dependence of the sarcomere length-tension relation of skinned cardiac cells. *J. Gen. Physiol.* **72**:667-699.
- FABIATO, A., and F. FABIATO. 1979 *a*. Tension developed and intracellular free calcium concentration reached during the twitch of an isolated cardiac cell with closed sarcolemma. *J. Gen. Physiol.* **74**:6a. (Abstr.).
- FABIATO, A., and F. FABIATO. 1979 *b*. Calculator programs for computing the composition of the solutions containing multiple metals and ligands used for experiments in skinned muscle cells. *J. Physiol. (Paris)*. **75**:463-505.
- FABIATO, A., and F. FABIATO. 1979 *c*. Use of chlorotetracycline fluorescence to demonstrate Ca<sup>2+</sup>-induced release of Ca<sup>2+</sup> from the sarcoplasmic reticulum of skinned cardiac cells. *Nature (Lond.)*. **281**:146-148.
- FABIATO, A., F. FABIATO, and E. H. SONNENBLICK. 1971. Electrical depolarization of intracellular membranes and "regenerative calcium release" in single cardiac cells with disrupted sarcolemmae. *Circulation*. **44**:II-90. (Abstr.).
- FISHER, V. J., R. J. LEE, A. M. MARLON, and F. KAVALER. 1967. Paired electrical stimulation and the maximal contractile response of the ventricle. *Circ. Res.* **20**:520-533.
- FORD, L. E., and R. J. PODOLSKY. 1972. Calcium uptake and force development by skinned muscle fibres in EGTA-buffered solutions. *J. Physiol. (Lond.)*. **223**:1-19.
- FORESTER, G. V., and G. W. MAINWOOD. 1974. Interval dependent inotropic effects in the rat myocardium and the effect of calcium. *Pfluegers Arch. Eur. J. Physiol.* **352**:189-196.
- GORDON, A. M., and E. B. RIDGWAY. 1978. Calcium transients and relaxation in single muscle fibers. *Eur. J. Cardiol. (Suppl.)* **7**:27-34.
- HARAFUJI, H., and Y. OGAWA. 1980. Re-examination of the apparent binding constant of ethylene glycol bis( $\beta$ -aminoethyl ether)-*N,N,N',N'*-tetraacetic acid with calcium around neutral pH. *J. Biochem. (Tokyo)*. **87**:1305-1312.
- HARNED, H. S., and B. B. OWEN. 1958. *The Physical Chemistry of Electrolytic Solutions*. American Chemical Society Monograph Series. Reinhold Publishing Corporation, New York. 3rd ed. 748. (Out of print; available from University Microfilms International, Ann Arbor, Mich.)
- HENDERSON, A. H., D. L. BRUTSAERT, W. W. PARMLEY, and E. H. SONNENBLICK. 1969. Myocardial mechanics in papillary muscles of the rat and cat. *Am J. Physiol.* **217**:1273-1279.
- HOLROYDE, M. J., E. HOWE, and R. J. SOLARO. 1979. Modification of calcium requirements for activation of cardiac myofibrillar ATPase by cyclic AMP dependent phosphorylation. *Biochim. Biophys. Acta.* **586**:63-69.
- ISENBERG, G., and U. KLÖCKNER. 1980. Glycocalyx is not required for slow inward calcium current in isolated rat heart myocytes. *Nature (Lond.)*. **284**:358-360.
- JOHNSON, J. D., S. C. CHARLTON, and J. D. POTTER. 1979. A fluorescence stopped flow analysis of Ca<sup>2+</sup> exchange with troponin C. *J. Biol. Chem.* **254**:3497-3502.
- KOCH-WESER, J., and J. R. BLINKS. 1963. The influence of the interval between beats on myocardial contractility. *Pharmacol. Rev.* **15**:601-652.
- KRUEGER, J. W., D. FORLETTI, and B. A. WITTENBERG. 1980. Uniform sarcomere shortening behavior in isolated cardiac muscle cells. *J. Gen. Physiol.* **76**:587-607.

- LEE, K. S., T. A. WEEKS, R. L. KAO, N. AKAIKE, and A. M. BROWN. 1979. Sodium current in single heart muscle cells. *Nature (Lond.)*. **278**:269-271.
- LEVY, R. M., Y. UMAZUME, and M. J. KUSHMERICK. 1976.  $\text{Ca}^{2+}$  dependence of tension and ADP production in segments of chemically skinned muscle fibers. *Biochim. Biophys. Acta*. **430**:352-365.
- MARBAN, E., T. J. RINK, R. W. TSIEN, and R. Y. TSIEN. 1980. Free calcium in heart muscle at rest and during contraction measured with  $\text{Ca}^{2+}$ -sensitive microelectrodes. *Nature (Lond.)*. **286**:845-850.
- MARTELL, A. E., and R. M. SMITH. 1974. Critical Stability Constants. Vol. 1: Amino Acids. Plenum Publishing Corp. New York. Introduction, p. xii.
- MCCLELLAN, G. B., and S. WINEGRAD. 1978. The regulation of the calcium sensitivity of the contractile system in mammalian cardiac muscle. *J. Gen. Physiol.* **72**:737-764.
- MEIJLER, F. L., F. VAN DEN BOGAARD, L. H. VAN DER TWEEL, and D. DURRER. 1962. Postextrasystolic potentiation in the isolated rat heart. *Am. J. Physiol.* **202**:631-635.
- MILLER, D. J. 1979. Are cardiac muscle cells 'skinned' by EGTA or EDTA? *Nature (Lond.)*. **277**:142-143.
- MOISESCU, D. G. 1976. Kinetics of reaction in calcium-activated skinned muscle fibres. *Nature (Lond.)*. **262**:610-613.
- MOISESCU, D. G., and C. C. ASHLEY. 1977. The effect of physiologically occurring cations upon aequorin light emission. Determination of the binding constants. *Biochim. Biophys. Acta*. **460**:189-205.
- MOPE, L., G. B. MCCLELLAN, and S. WINEGRAD. 1980. Calcium sensitivity of the contractile system and phosphorylation of troponin in hyperpermeable cardiac cells. *J. Gen. Physiol.* **75**:271-282.
- OGAWA, Y. 1968. The apparent binding constant of glycoetherdiaminetetraacetic acid for calcium at neutral pH. *J. Biochem. (Tokyo)*. **64**:255-257.
- PAGE, E., and M. SURDYK-DROSKE. 1979. Distribution, surface density, and membrane area of diadic junctional contacts between plasma membrane and terminal cisterns in mammalian ventricle. *Circ. Res.* **45**:260-267.
- POWELL, T., and V. W. TWIST. 1976. A rapid technique for the isolation and purification of adult cardiac muscle cells having respiratory control and a tolerance to calcium. *Biochem. Biophys. Res. Commun.* **72**:327-333.
- POWELL, T., D. A. TERRAR, and V. W. TWIST. 1980. Electrical properties of individual cells isolated from adult rat ventricular myocardium. *J. Physiol. (Lond.)*. **302**:131-153.
- REUBEN, J. P., and D. S. WOOD. 1979. Are cardiac muscle cells skinned by EGTA or EDTA? *Nature (Lond.)*. **280**:700-701.
- RIDGWAY, E. B., and C. C. ASHLEY. 1967. Calcium transients in single muscle fibers. *Biochem. Biophys. Res. Commun.* **29**:229-234.
- SCHWARZENBACH, v. G., H. SENN, and G. ANDEREGG. 1957. Komplexe. XXIX. Ein grosser Chelateffekt besonderer Art. *Helv. Chim. Acta*. **40**:1886-1900.
- TARR, M., J. W. TRANK, P. LEIFFER, and N. SHEPHERD. 1979. Sarcomere length-resting tension relation in single frog atrial cardiac cells. *Circ. Res.* **45**:554-559.
- TSIEN, R. W. 1977. Cyclic AMP and contractile activity in heart. In *Advances in Cyclic Nucleotide Research*. P. Greengard and G. A. Robison, editors. Raven Press, New York. **8**:363-420.
- TSIEN, R. Y. 1980. New calcium indicators and buffers with high selectivity against magnesium and protons: design, synthesis, and properties of prototype structures. *Biochemistry*. **19**:2396-2404.



- VAHOUNY, G. V., R. WEI, R. STARKWEATHER, and C. DAVIS. 1970. Preparation of beating heart cells from adult rats. *Science (Wash. D. C.)*. **167**:1616-1618.
- WIER, W. G. 1980. Calcium transients during excitation-contraction coupling in mammalian heart: aequorin signals of canine Purkinje fibers. *Science (Wash. D. C.)*. **207**:1085-1087.
- WINEGRAD, S. 1971. Studies of cardiac muscle with a high permeability to calcium produced by treatment with ethylenediaminetetraacetic acid. *J. Gen. Physiol.* **58**:71-93.
- WINEGRAD, S. 1979a. Electromechanical coupling in heart muscle. *In Handbook of Physiology, Section 2: The Cardiovascular System. Vol. I: The Heart.* R. M. Berne, N. Sperelakis, and S. R. Geiger, editors. American Physiological Society, Bethesda, Md. 393-428.
- WINEGRAD, S. 1979b. Are cardiac muscle cells skinned by EGTA or EDTA? *Nature. (Lond.)*. **280**: 701-702.